

# INSTRUCTION MANUAL BOOK & PARTS BOOK

---

NF3901AUT/3901LH-AUT Series  
**HIGH-SPEED LOCKSTITCH SEWING  
MACHINE WITH MOTOR BUILT IN HEAD**



十分感谢您购买GLOBAL牌工业缝纫机。

为了您的安全，在使用缝纫机之前，请仔细阅读产品说明书。

Thank you very much for buying a GLOBAL sewing machine.

Before using your new machine, please read the safety instructions.

工业缝纫机的特性之一，因为要在机针和旋梭等运动零部件附近进行操作，而这些零部件很容易引起损伤的危险，所以请在受过培训的人或熟练人员的安全操作知识的指导下，正确的使用此缝纫机。

With industrial sewing machines, it is normal to carry out work while positioned directly in front of moving parts such as the needle and thread take-up, and consequently there is always a danger of injury that can be caused by these parts. Follow the instructions from training personnel and instructors regarding safe and operation before operating the machine so that you will know how to use it correctly.

## 一、为了你的安全使用/SAFETY INSTRUCTIONS

### [1]. 安全使用的标记及其意义/safety indications and their meanings

本使用说明书及产品所使用的标记和图案记号是为了你的安全而正确地使用产品，防止你及其他人受到危害和损害。表示方法及含义如下。

This instruction manual and the indications and symbols that are used on the machine itself are provided in order to ensure safe operation of this machine and to prevent accidents and injury to yourself or other people

#### 标记/indications

 危险/DANGER 表示如果忽视此标记而进行了错误的操作，肯定会引起人员伤亡或重伤。

The instructions which follow this term indicate situations where failure to follow the instructions will almost certainly result in death or severe injury.

 注意/DANGER 表示如果忽视此标记而进行了错误的操作，有可能会引起人员受伤及造成设备损坏。 The instructions which follow this term indicate situations where failure to follow the instructions could injury when using the machine or physical damage to equipment and surroundings.

#### 图案和符号/symbols

 该符号表示“应注意事项”。三角形中的图案表示必须要注意的实质内容（例如：左边的图案表示“当心受伤”。） This symbol indicates something that you should be careful of. The picture inside the triangle indicates the nature of the caution that must be taken. (for example, the symbol at left means “beware of injury” .)

 该符号表示“禁止”。 This symbol indicates something that you must not do.

 该符号表示“必须”。圆圈中的图案表示必须要做的事情的实质内容。（例如，左边的图案表示“必须接地”） This symbol indicates something that you must do. The picture inside the circle indicates the nature of the thing that must be done. (for example, the symbol at left means “you must make the ground connection” .)

### [2].安全注意事项/Notes on safety

 打开控制箱盖时，先关闭电源开关并将电源插头从插座上拔下，至少 5 分钟后，在打开控制箱盖，触摸带有高电压的区域将会造成人员受伤。 Wait at east 5 minutes after turning off the power switch and disconnect the power cord from the wall outlet before opening the face plate of the control box. Touching areas where high voltages are present can result in severe injury.

### [3].警告标签/Warning labels

缝纫机上有下列警告标签。当使用缝纫机时，请遵守标签上的说明。如果标签说明脱落或模糊不清，请和购买商店联系。

The following warning labels appear on the machine. Please follow the instructions on the labels at all times when using the machine .if labels have been removed or are difficult to read, please contact your nearest GLOBAL dealer.

安全保护装置/Safety devices

- (A)护指器 Finger guard
- (B)挑线杆防护罩 Thread take-up cover
- (C)

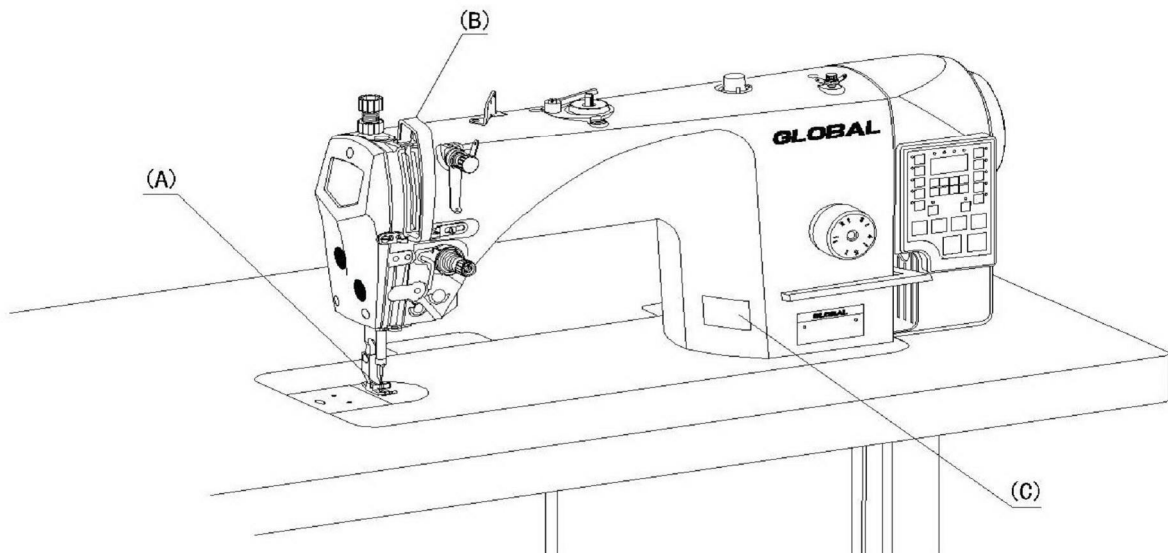

## 二、使用环境/Environmental requirements

**!** 相对湿度应在 45%~85%范围内，并且设备内不会形成结露的环境下使用。干燥或多湿的环境和结露会影响缝纫机的正确操作。The relative humidity should be within the range of 45%to85% during use, and no dew formation should occur in any devices. Excessively dry or humid environments and dew formation may cause problems with correct operation.

**!** 使用时应避免暴露于直射的阳光下。直射的阳光下会影响缝纫机的正确操作。Avoid exposure to direct sunlight during use. Exposure to direct sunlight may cause problems with correct operation.

**!** 万一发生雷电暴风雨时，关闭电源开关，并将电源插头从插座上拔下。雷电可能会影响缝纫机的正确操作。In the event of an electrical storm, turn off the power and disconnect the power cord from the wall outlet .lightning may cause problems with correct operation.

### 三、安装/installation

 请让受过培训的技术人员来安装缝纫机。 Machine installation should only be carried out by a qualified technician.

 在安装完成前，请不要连接电源，如果误踩下脚踏板时，缝纫机动作会导致受伤。 Do not connect the power cord until installation is complete. The machine may operate if the treadle is depressed by mistake, which could result in injury.

 使用润滑油和黄油时，务必戴好保护眼镜和保护手套等，以防润滑油落入眼中或沾在皮肤上，引起发炎。另外，润滑油或黄油不能饮用，否则会引起呕吐和腹泻。将油放在小孩拿不到的地方。

Be sure to wear protective goggles and gloves when handling the lubricating oil and grease, so that they do not get into your eyes or onto your skin, otherwise inflammation can result. Furthermore, do not drink the oil or eat the grease under any circumstances, as they can cause vomiting and diarrhea. Keep the oil out of the reach of children.

 缝纫机重 48Kg, 安装工作必须由两人以上来完成。 The sewing machine weighs more than 48 Kg. the installation should be carried out by two or more people.

 请在切断电源后，再拔掉插头。不然易成为控制箱发生故障的原因。 Turn off the power switch before inserting or removing the plug, otherwise damage to the control box could result.

 如果使用带小脚轮的工作台，则应该固定小脚轮，使其不能移动。 If using a work table which has casters, the casters should be secured in such a way so that they cannot move.

 缝纫机头倒下或竖起时，请用双手进行操作。单手操作时因缝纫机的重量万一滑落易导致受伤。

Use both hands to hold the machine head when tilting it back or returning it to its original position. If only one hand is used, the weight of the machine head may cause your hand to slip, and your hand may get caught.

 固定电缆时，不要过度弯曲电缆或用卡钉固定过紧，会引起火灾或触电的危险。 When securing the cords, do not bend the cords excessively or fasten them too hard with staples, otherwise there is the danger that fire or electric shocks could occur.

### 四、缝纫/Sewing

 本缝纫机仅限于接受过安全操作培训的人员使用。 This sewing machine should only be used by operators who have received the necessary training in safe use beforehand.

 本缝纫机不能用于除缝纫外的任何其他用途。 This sewing machine should not be used by any applications other than sewing.

 使用缝纫机时必须戴上保护眼镜。如果不戴保护眼镜，断针时就会有危险，机针的折断部分可能会弹入眼睛并造成伤害。 Be sure to wear protective goggles when using the machine. If goggles are not worn, there is the danger that if a needle breaks, parts of the broken needle may enter your eyes and injury may result.

 如果使用带小脚轮的工作台，则应该固定小脚轮使其不能移动。 If using a work table which has casters should be secured in such a way so that they cannot move.





 最初使用缝纫机时，应进行 20 天的低速磨合运转 ( $\leq 3500$  r/min) at first operate the machine, should carry on low speed to whet to match an operation for 20 days.(3500 r/min)

 如果缝纫机操作发生误动作，或听到异常的噪音或闻到异常的气味，应立即切断电源。然后请与购买商店或受过培训的技术人员联系。If an error occurs in machine, or if abnormal noises or smells are noticed, immediately turn off the power switch. Then contact your nearest dealer or a qualified technician.

 如果缝纫机出现故障，请与购买商店或受过培训的技术人员联系。If the machine develops a problem, contact your nearest dealer or a qualified technician.

 发生下列情况时，请切断电源。否则误踩下踏板时，缝纫机动作会导致受伤。1.机针穿线时。2.更换机针或梭芯时。3.缝纫机不使用或人离开缝纫机时。Turn off the power switch at the following times. The machine may operate if the treadle is depressed by mistake, which could result in injury. 1. When threading the needle. 2. When replacing the bobble and needle. 3. When not using the machine and when leaving the machine unattended.

 为了安全起见，在使用缝纫机之前，请安装保护装置。如果未安装这些装置就使用缝纫机，会造成人身伤害及缝纫机损坏。Attach all safety devices before using the sewing machine. If the machine is used without these devices attached, injury may result.

 缝纫过程中，不要触摸任何运动部件或将物体靠在运动部件上，因为这会导致人身伤害及缝纫机损坏。Do not touch any of the moving parts or press any objects against the machine while sewing, as this may result in personal injury or damage to the machine.

 缝纫机头倒下或竖起时，请用双手进行操作。单手操作时因缝纫机的重量万一滑落易导致受伤。  
Use both hands to hold the machine head when tilting it back or returning it to its original position. If only one hand is used, the weight of the machine head may cause your hand to slip, and your hand may get caught.

## 五、清洁/Cleaning

 在开始清洁作业前，请切断电源。如果误踩下踏板时，缝纫机动作会导致人员受伤。Turn off the power switch before carrying out cleaning. The machine may operate if the treadle is depressed by mistake, which could result in injury.

 缝纫机头倒下或竖起时，请用双手进行操作。单手操作时因缝纫机的重量万一滑落易导致受伤。  
Use both hands to hold the machine head when tilting it back or returning it to its original position. If only one hand is used, the weight of the machine head may cause your hand to slip, and your hand may get caught.

 使用润滑油和黄油时，务必戴好保护眼镜和保护手套等，以防润滑油落入眼中或沾在皮肤上，引起发炎。另外，润滑油或黄油不能饮用，否则会引起呕吐和腹泻。将油放在小孩拿不到的地方。Be sure to wear protective goggles and gloves when handling the lubricating oil and grease, so that they do not get into your eyes or onto your skin, otherwise inflammation can result. Furthermore, do not drink the oil or eat the grease under any circumstances, as they can cause vomiting and diarrhea. Keep the oil out of the reach of children.

 用本公司指定更换的零部件。Use only the proper replacement parts as specified by .

## 六、保养和检查/Maintenance and inspection

 只有经过训练的技术人员才能进行缝纫机的维修，保养和检查。Maintenance and inspection of the sewing machine should only be carried out by a qualified technician.

 由顾客擅自改造机器而导致的任何问题本公司不负一切责任。Any problem in machine operation which results from unauthorized modifications to the machine will not be covered by the warranty.

 发生下列情况下，请关闭电源并从电源插座上拔下插头。否则误踩下脚踏板时，缝纫机动作会导致受伤。1.检查、调整或维修。2.更换旋梭等易损坏零部件。Turn off the power switch and disconnect the power cord from the wall outlet at following times, otherwise the machine may operate if the treadle is depressed by mistake, which could result in injury. 1. When carrying out inspection, adjustment and maintenance. 2. When replacing consumable parts such as the rotary hook.

 在必须接上电源开关进行调整时，务必十分小心遵守所有的安全注意事项。If the power switch needs to be left on when carrying out some adjustment, be extremely careful to observe all safety precautions.

 缝纫机头倒下或竖起时，请用双手进行操作。单手操作时因缝纫机的重量万一滑落易导致受伤。

Use both hands to hold the machine head when tilting it back or returning it to its original position. If only one hand is used, the weight of the machine head may cause your hand to slip, and your hand may get caught.

 与电气有关的维修、保养和检查请委托购买商店或电气工作人员进行。Ask your dealer or a qualified electrician to carry out any maintenance and inspection of the electrical system.

 取下的安全保护装置，再次安装时，请务必安装在原位上，并检查能否正常的发挥作用。If any safety devices have been removed, be absolutely sure to reinstall them to their original positions and check that they operate correctly before using the machine.

 请使用本公司指定更换的零部件。Use only the proper replacement parts as specified by GLOBAL.

# 目录 CONTENTS

## INSTRUCTION MANUAL 使用说明

1. SPECIFICATIONS 规格.....	1
2. INSTALLATION 缝纫机的安装 .....	1
3. ADJUSTING THE HEIGHT OF THE KNEE LIFTER 膝动提升高度的调整 .....	2
4. INSTALLING THE THREAD STAN 线架装置的安装 .....	2
5. LUBRICATION 加油 .....	3
6. ATTACHING THE NEEDLE 机针的安装方法 .....	4
7. SETTING THE BOBBIN INTO THE BOBBIN CASE 梭芯的安装方法 .....	4
8. ADJUSTING THE STITCH LENGTH 缝迹长度的调节 .....	5
9. PRESSER FOOT PRESSURE 压脚压力的调节 .....	5
10. HAND LIFTER 压脚提升 .....	5
11. ADJUSTING THE HEIGHT OF THE PRESSER BAR 压脚高度的调节 .....	6
12. THREAD TENSION 线张力 .....	6
13. THREAD TAKE-UP SPRING 挑线弹簧 .....	6
14. ADJUSTING THE THREAD TAKE-UP STROKE 挑线杆挑线量的调整 .....	7
15. THREADING THE MACHINE HEAD 上线穿线方法 .....	7
16. NEEDLE-TO-HOOK RELATIONSHIP 机针和旋梭的关系 .....	8
17. ADJUSTING THE FEED TIMING 送布相位的调节 .....	8
18. HEIGHT OF THE FEED DOG 送布牙的高度 .....	9
19. TILT OF THE FEED DOG 送布牙的倾斜度 .....	9
20. REPLACING THE COUNTER KNIFE 固定刀的更换 .....	9
21. PEDAL PRESSURE AND PEDAL STROKE 踏板压力和行程 .....	10
22. ADJUSTMENT OF THE PEDAL 踏板的调整 .....	10
23. PEDAL OPERATION 踏板的操作 .....	10

## PARTS 零件图

1. MACHINE FRAME & MISCELLANEOUS COVER COMPONENTS 机壳分组件.....	11-14
2. MAIN SHAFT COMPONENTS 上轴分组件 .....	15-16
3. NEEDLE BAR, UPRIGHT SHAFT & HOOK DRIVING SHAFT COMPONENTS 针杆、竖轴及旋梭驱动轴分组件 .....	17-18
4. HAND LIFTER COMPONENTS 压脚分组件 .....	19-20
5. FEED MECHANISM COMPONENTS 送料分组件 .....	21-24
6. THREAD TRIMMER COMPONENTS 自动切线 .....	25-26
7. NEEDLE BAR FRAME COMPONENTS 摆针分组件 .....	27-28
8. AUTOMATIC REVERSE FEED MECHANISM COMPONENTS 自动倒缝分组件 .....	29-30
9. WIPER COMPONENTS OR THREAD TENSION 拨线或夹线分组件 .....	31-32
10. OIL LUBRICATION COMPONENTS 润滑分组件 .....	33-34
11. DRIVER COMPONENTS 电控分组件 .....	35
12. OIL RESERVOIR COMPONENTS 油盘分组件 .....	36-37
13. ACCESSORIES 附件 .....	38-39
14. PRESSER FOOT LIFTING SET MECHANISM (OPTION PARTS) 自动抬压脚电磁铁 (选购) .....	40
15. EXCLUSIVE PARES FOR 3901-LH AUT /3901-LH AUT 专用件 .....	41-42

## 1. SPECIFICATIONS

Application	General fabrics and medium-weight materials
Sewing speed	Max.5,000 sti/min
	(If stitch is set at 4 mm or more,set the sewing speed at 4,000 sti/min)
Stitch length	Max.5 mm(Stitch length for reverse feed stitching:3 mm)
Needle	DB*5 #9~18 (standard#14)
Presser foot lift (by knee lifter)	10 mm(standard),13 mm(max)
Stroke of the cloth cutting knife	6.5mm
Lubricating oil	New Defrix Oil No.10
Noise	<ul style="list-style-type: none"> <li>- Equivalent continuous emission sound pressure level ( Lpa)at the workstation: A-weighted value of 82.0 dB; ( Includes KPA=2.5dB );according to I OS 10821 - C.6.2 - I OS 11204 GR2 at 5,000 sit/min.</li> <li>- Sound power level ( LWA); A- weighted value of 89.0 dB;( Includes KWA=2.5dB ); according to I OS 10821 - C.6.2 - IOS 11204 GR2 at 5,000 sit/min.</li> </ul>

## 1. 规格

用途	一般布料，中厚料
缝纫速度	最高5,000sti/min (缝距4mm以上为4,000sti/min)
最大缝距	5mm (倒缝为3mm)
使用机针	DB*5#9~18 (标准#14)
压脚高度 (膝动提升)	6 mm(标准), 13 mm(最大)
切布刀行程	6.5mm
使用机油	NO.10 New Defrix Oil

## 2. INSTALLATION/缝纫机的安装

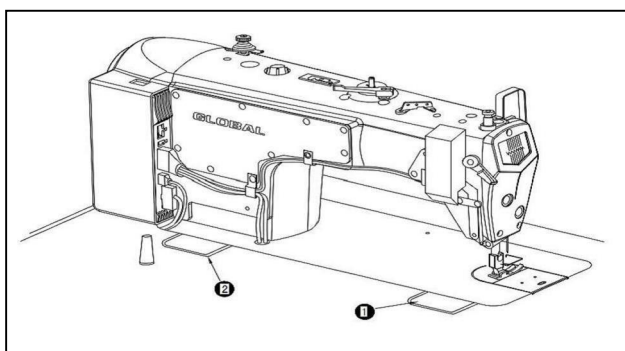
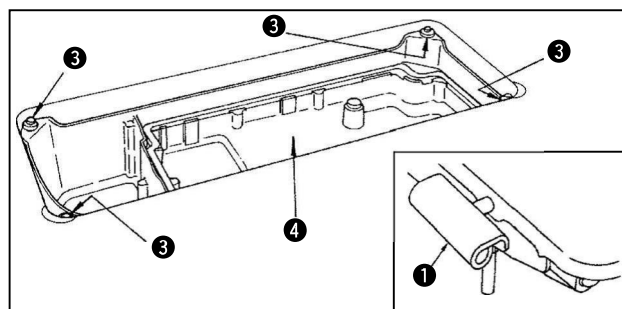
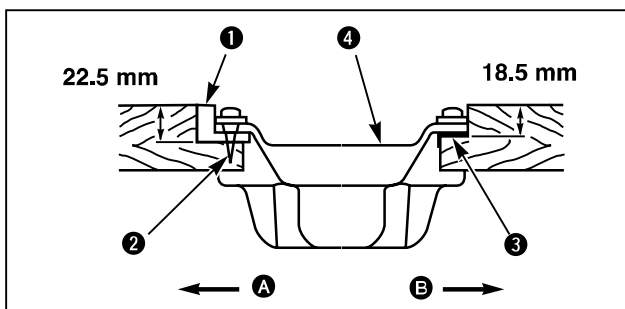

### (1) Installing the under cover

- 1) The oil pan should rest on the four corners of the machine table groove.
- 2) Two rubber seats ① for supporting the head portion on the operator side A are fixed on the extended portion of the table by hitting the nail ②, and the other two rubber cushion seats ③ on the hinge side B are fixed by using a rubber-based adhesive. Then, oil pan ④ is placed.

#### 1. 油槽的安装

- 1) 把油槽支到机台的四角上。
- 2) 用螺钉 ② 把前侧 A 的2个头部橡胶支座 ① 钉到机台的伸出部，用粘接剂粘接固定好铰链侧 B 的2个部胶垫座 ③，然后把油槽 ④ 放上去。
- 3) Fit hinge ① into the opening in the machine bed, and fit the machine head to table rubber hinge ② before placing the machine head on cushions ③ on the four corners.
- 3) 把铰链 ① 放到机台的孔上，对准台板橡胶支座 ②，把头部放到四角的机头橡胶垫 ③ 上。

### 3. ADJUSTING THE HELGHT OF THE KNEE LIFTER/膝控提升高度的调整

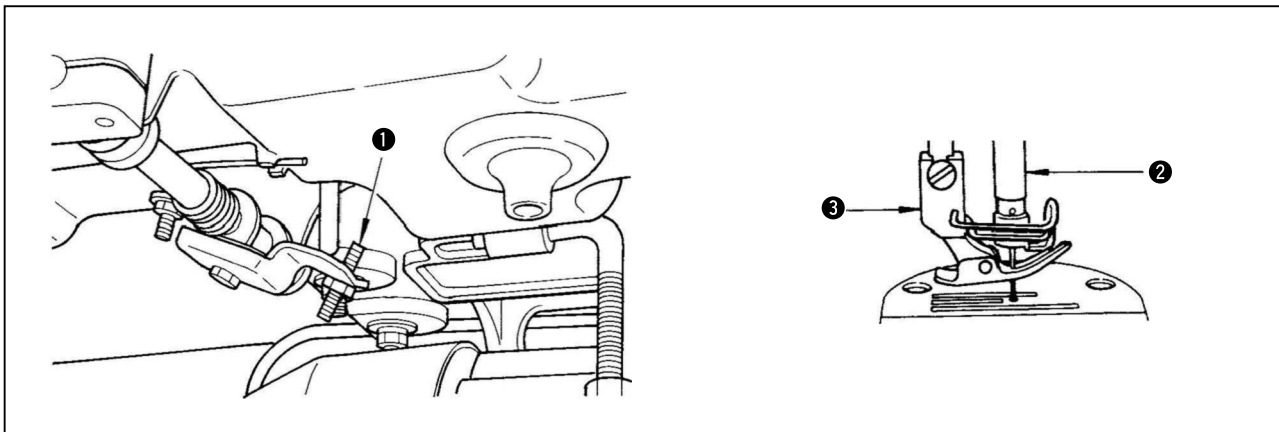

- 1) The standard height of the presser foot lifted using the knee lifter is 10 mm.
- 2) You can adjust the presser foot lift up to 13 mm using knee lifter adjust screw ①. (Max. 9 mm for A type)
- 3) When you have adjusted the presser foot lift to over 10 mm, be sure that the bottom end of needle bar ② in its lowest position does not hit presser foot ③.
- 1) 用膝控时的标准压脚高度是10毫米。
- 2) 用膝提调整螺钉 ① 可以调节压脚提升量至13毫米。
- 3) 当压脚提升超过10毫米时，不能使处于最低位置的针杆 ② 底端与压脚 ③ 相碰。

### 4. INSTALLING THE THREAD STAND/线架装置的安装

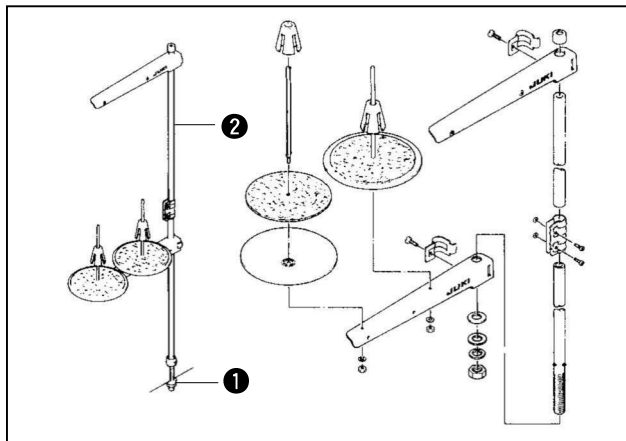

- 1) Tighten locknut to fix the thread stand.
- 2) For ceiling wiring, pass the power cord through spool rest rod .

- 1) 固定线架不让线架松动，然后拧紧螺母 ①。
- 2) 进行顶部配线时，请把电源线从线架杆 ② 中穿过。

## 5. LUBRICATION/加油



### WARNING :

To protect against possible personal injury due to abrupt start of the machine, be sure to start the following work after turning the power off and ascertaining that the motor is at rest.

警告：为了防止突然的起动造成的事故，请关掉电源后再进行操作。

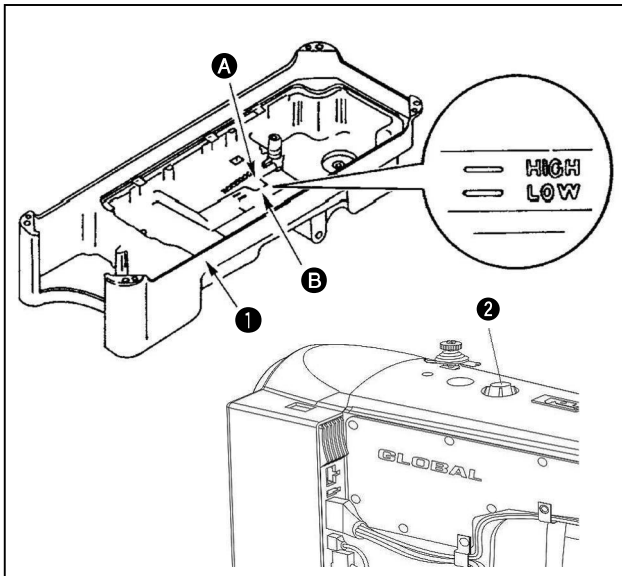

### (1).Information on lubrication

- 1) Fill oil pan ① with New Defrix Oil No.10 up to HIGH mark ①.
- 2) When the oil level lowers below LOW mark ②, refill the oil pan with the specified oil.
- 3) When you operate the machine after lubrication, you will see splashing oil through oil sight window ② if the lubrication is adequate.
- 4) Note that the amount of the splashing oil is unrelated to the amount of the lubricating oil.

#### (1). 缝纫机运转之前

- 1) 把No. 10 白油加入到油槽 ①，加到HIGH 标记 ① 的位置。
- 2) 如果油面降到LOWE标记 ② 以下时，请再次把油加满。
- 3) 加油后运转缝纫机，润滑正常时应能看到油窗 ② 里油面跳动。
- 4) 油跳动量的大小与油量的多少无关，因此不用担心。

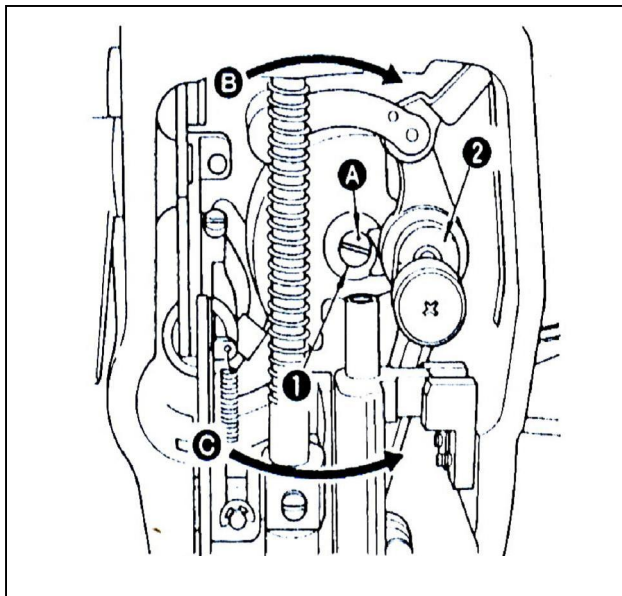

### (2).Adjusting the amount of oil supplied to the face plate parts

- 1) Adjust the amount of oil supplied to the thread take-up and needle bar crank ② by turning adjust pin ①.
- 2) The minimum amount of oil is reached when marker dot ② is brought close to needle bar crank ② by turning the adjust pin in direction ③.
- 3) The maximum amount of oil is reached when marker dot ② is brought to the position just opposite from the needle bar crank by turning the adjust pin in direction ④.

#### (2). 面部油量调节

- 1) 转动油量调节销 ① 可以调节挑线曲柄 ② 的供油量。
- 2) 油量调节销朝B方向转动，刻点A靠近挑线曲柄 ② 时，油量达到最小值。
- 3) 油量调节销朝C方向转动，刻点A背离挑线曲柄 ② 时，油量达到最大值。

### (3)Adjusting the amount of oil (oil spots) in the hook

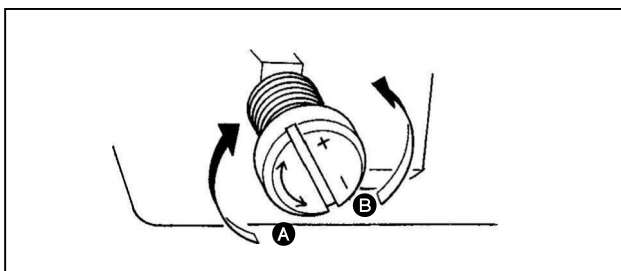

- 1) Turning the oil amount adjustment screw attached on the hook driving shaft front bushing in the "+" direction (in direction ①) will increase the amount of oil (oil spots) in the hook, or in the "-" direction (in direction ②) will decrease it.
- 2) After the amount of oil in the hook has been properly adjusted with the oil amount adjustment screw, make the sewing machine run idle for approximately 30 seconds to check the amount of oil in the hook.

#### (3). 旋梭部油量的调节方法

把下轴前部的油量调节螺丝向 + 方向 (A方向) 转动油量 (迹) 增多，向 - 方向 (B方向) 转动则油量 (迹) 减少。



## 6. ATTACHING THE NEEDLE/机针的安装方法



### WARNING :

To protect against possible personal injury due to abrupt start of the machine, be sure to start the following work after turning the power off and ascertaining that the motor is at rest.

### 警告:

为了防止突然的起动造成的事故，请关掉电源后再进行操作。

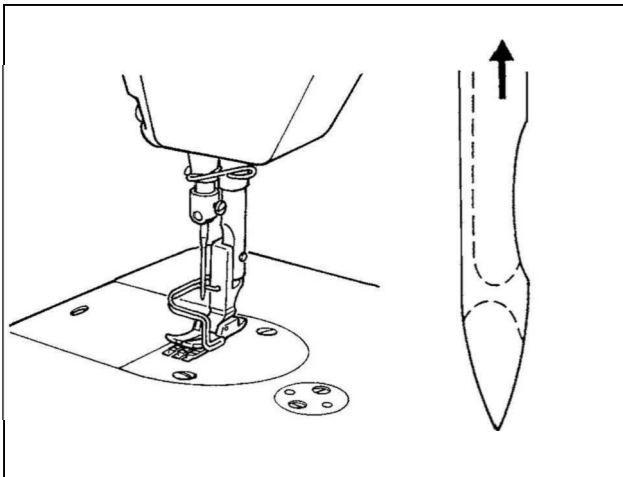

Loosen screw ②, and hold needle ① with its indented part ① facing exactly to the right in direction ②. Insert the needle fully into the needle bar in the direction of the arrow until the end of hole is reached.

拧松机针固定螺丝 ②，手拿机针，把机针 ① 凹部 ① 横向转到 ② 的方向。然后把机针沿箭头方向插进针杆孔的深处。

## 7. SETTING THE BOBBIN INTO THE BOBBIN CASE/梭芯的安装方法

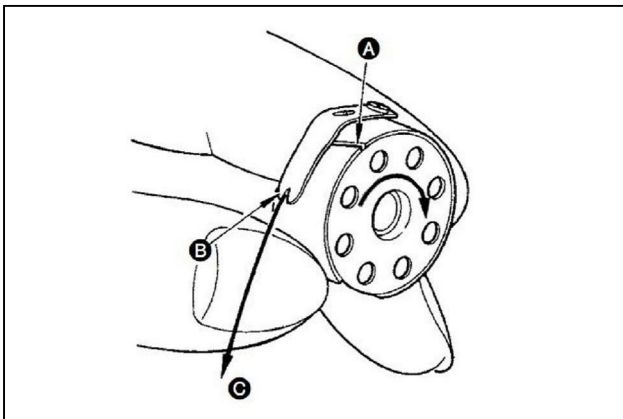

- 1) Pass the thread through thread slit ①, and pull the thread in direction ②.  
By so doing, the thread will pass under the tension spring and come out from notch ③.
- 2) Check that the bobbin rotates in the direction of the arrow when thread ④ is pulled.

- 1) 手拿梭芯，让线往左卷绕的方向，把它放入梭壳。
- 2) 把线穿过梭壳的穿线口 ①，然后把线往 ② 方向，从线张力弹簧下面的穿线口 ③ 拉出来。

## 8. ADJUSTING THE STITCH LENGTH/缝线长度的调节

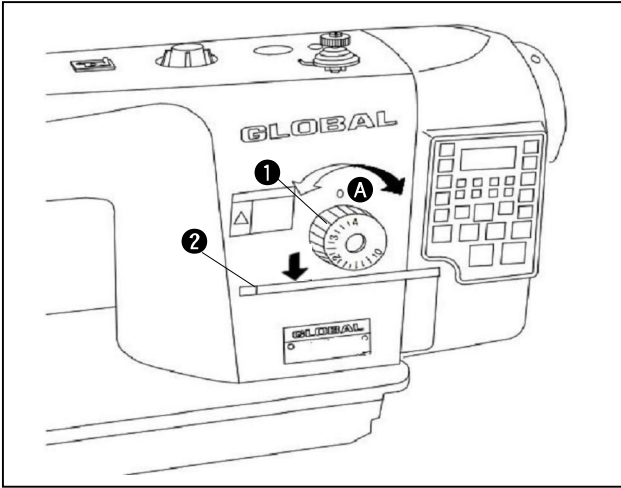

- 1) Turn stitch dial in the direction of the arrow, and align the desired number to marker dot on the machine arm.
- 2) When you want to decrease the stitch length, turn stitch length dial while pressing feed lever in the direction of the arrow.

- 1) 沿箭头方向转动送布调节刻度盘 ①，并把希望的数字对准机臂的刻点 A。
- 2) 从大往小变更送布刻度时，请在朝箭头方向按下送布拨杆 ② 的同时转动调节刻度盘 ① 便可以调节。

## 9. PRESSER FOOT PRESSURE/压脚压力调节

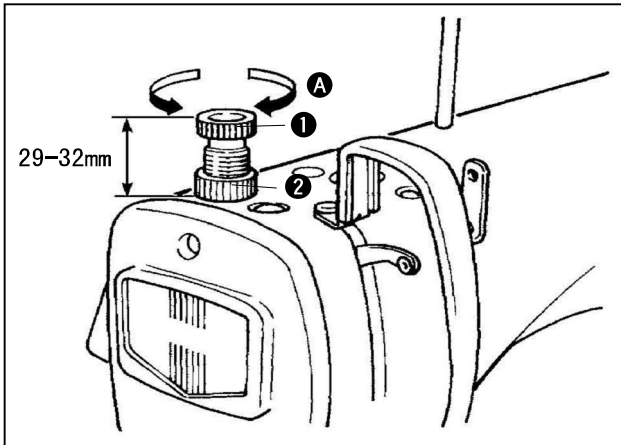

Loosen nut ②. As you turn presser spring regulator ① clockwise (in direction A), the presser foot pressure will be increased.

拧松螺母 ②，向右 A 的方向转动调节螺丝 ① 压脚压力变强

## 10. HAND LIFTER/压脚提升

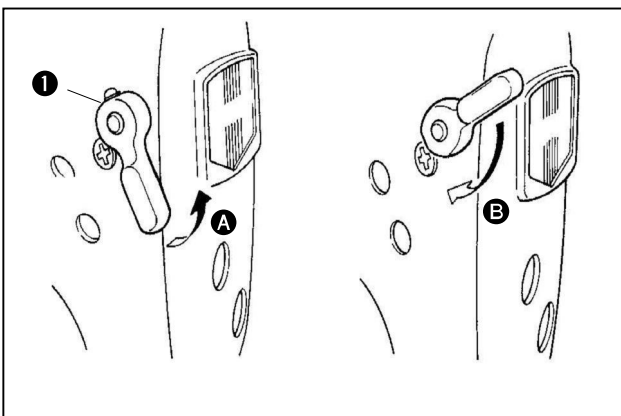

- 1) To stop the machine with its presser foot up, turn hand lifter lever ① in direction A.
- 2) The presser foot will go up about 5.5mm and stop. The presser foot will go back to its original position when hand lifter lever is turned down in direction B.

- 1) 停机将压脚扳手 ① 朝 A 方向转动，使压脚抬起。
- 2) 压脚的抬起量约为 5.5 毫米。当压脚扳手 ① 朝 B 方向转动时，压脚将放回原来位置。

## 11. ADJUSTING THE HEIGHT OF THE PRESSER BAR/压脚高度的调整



### WARNING :

To protect against possible personal injury due to abrupt start of the machine, be sure to start the following work after turning the power off and ascertaining that the motor is at rest.

警告：

为了防止突然的起动造成的事故，请关掉电源后再进行操作。

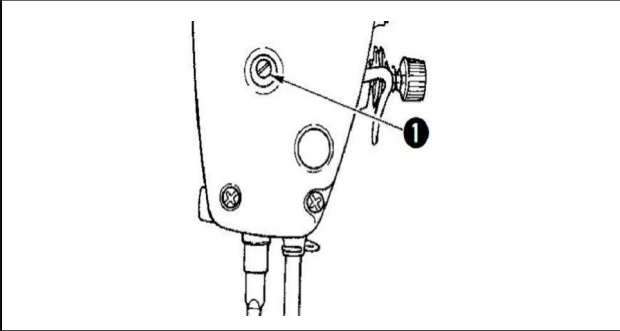

- 1) Loosen setscrew ①, and adjust the presser bar height or the angle of the presser foot.
- 2) After adjustment, securely tighten the setscrew ①.

- 1) 变更压脚的高度或角度时，请拧松压脚杆套固定螺丝 ①，进行调节。
- 2) 调节后，把固定螺丝 ① 拧紧固定。

## 12. THREAD TENSION/线张力

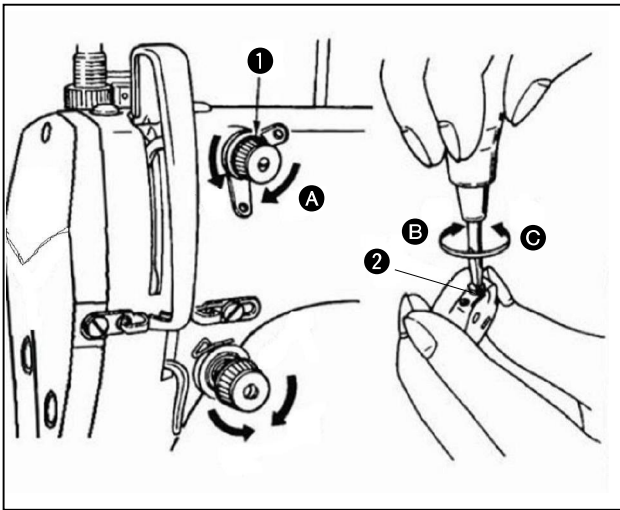

1. As you turn thread tension No.1 nut ① clockwise (in direction A), the thread remaining on the needle after thread trimming will be shorter.

### 2. Adjusting the bobbin thread tension

- 1) As you turn tension adjust screw ② clockwise (in direction B), the bobbin thread tension will increase.
- 2) As you turn screw ② counterclockwise (in Direction C), the bobbin thread tension will decrease.

1. 把第一线张力螺母 ① 向右 A 方向转动，切线后针尖残留的线长度变短。

### 2. 底线张力的调节：

- 1) 将夹线螺钉 ② 按顺时针方向（即 B 方向）转动时，底线张力增大。
- 2) 将夹线螺钉 ② 按逆时针方向（即 C 方向）转动时，底线张力减小。

## 13. THREAD TAKE-UP SPRING/挑线弹簧

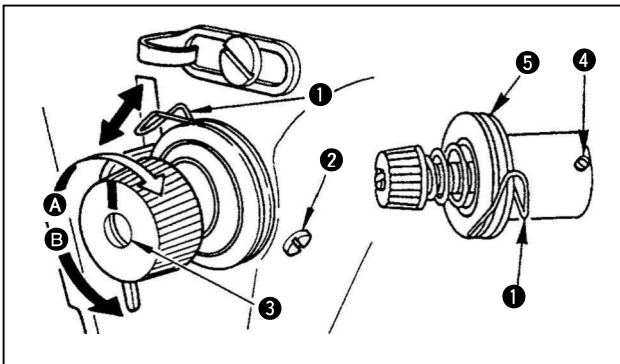

### (1) Changing the stroke of thread take-up spring ①

- 1) Loosen setscrew ②.
- 2) As you turn tension post ③ clockwise (in direction A), the stroke of the thread take-up spring will be increased.
- 3) As you turn the knob counterclockwise (in direction B), the stroke will be decreased.

### (2) Changing the pressure of thread take-up spring ①

- 1) Loosen setscrew ②, and remove tension post ③.
- 2) Loosen setscrew ④.
- 3) As you turn tension post ③ clockwise (in direction A), the pressure will be increased.
- 4) As you turn the tension post counterclockwise (in direction B), the pressure will be decreased.

1. 改变挑线簧 ① 的行程量时
  - 1) 拧松线张力器的固定螺丝 ②。
  - 2) 把线张力杆 ③ 向右 A 的方向转动，行程量变大。
  - 3) 向左 B 的方向转动，行程量变小。
2. 改变挑线弹簧 ① 的压力时
  - 1) 拧松固定螺丝 ②，卸下张力器（组件）⑤。
  - 2) 拧松线张力杆固定螺丝 ④ 进行调节。
  - 3) 把线张力杆 ③ 向右 A 的方向转动，压力变强。
  - 4) 向左 B 的方向转动，压力变弱。

## 14. ADJUSTING THE THREAD TAKE-UP STROKE/挑线杆挑线量的调整



### WARNING :

To protect against possible personal injury due to abrupt start of the machine, be sure to start the following work after turning the power off and ascertaining that the motor is at rest.

警告：

为了防止突然的起动造成的事故，请关掉电源后再进行操作。

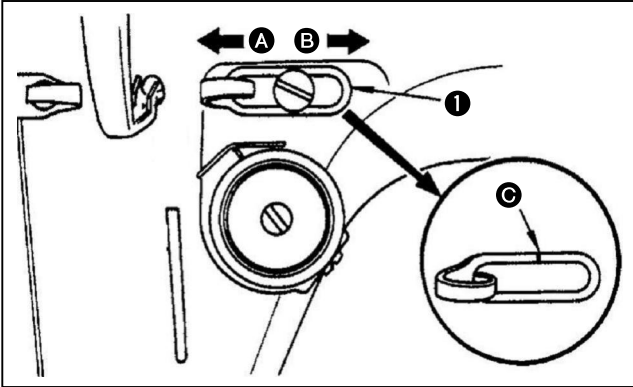

- 1) When sewing heavy-weight materials, move thread guide ① to the left (in direction A) to increase the length of thread pulled out by the thread take-up.
- 2) When sewing light-weight materials, move thread guide ① to the right (in direction B) to decrease the length of thread pulled out by the thread take-up.
- 3) Normally, thread guide ① is positioned in a way that marker line C is aligned with the center of the screw.

- 1) 缝制厚料时，把导线器①向左A的方向移动，挑线量变化大。
- 2) 缝制薄料时，把导线器①向右B的方向移动，挑线量变化小。
- 3) 导线器①的刻线C在螺丝的中心位置左面1mm为标准位置。

## 15. THREADING THE MACHINE HEAD/上线穿线方法



### WARNING :

To protect against possible personal injury due to abrupt start of the machine, be sure to start the following work after turning the power off and ascertaining that the motor is at rest.

警告：

为了防止突然的起动造成的事故，请关掉电源后再进行操作。

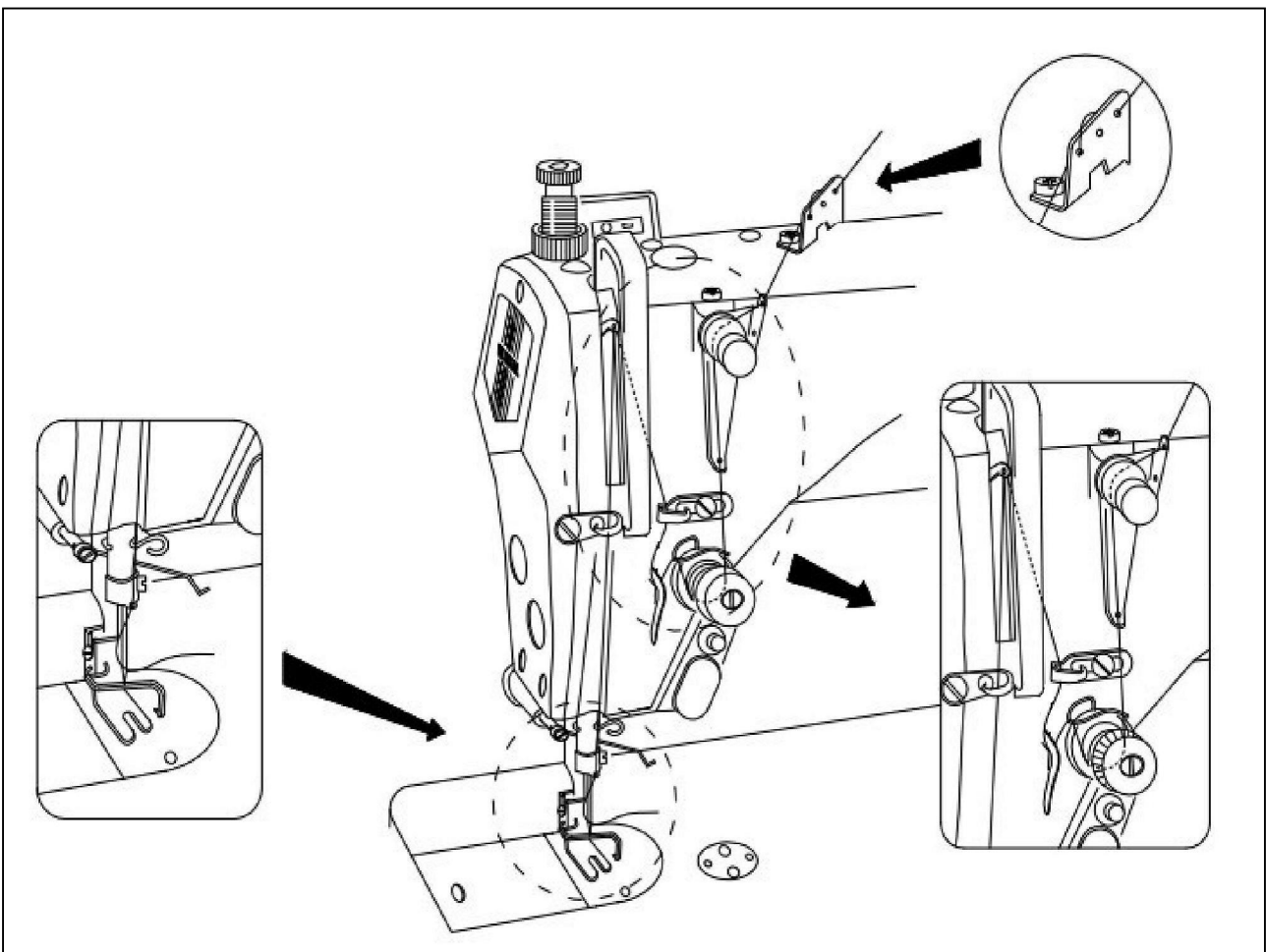

## 16. NEEDLE-TO-HOOK RELATIONSHI / 机针和旋梭的关系



### WARNING :

To protect against possible personal injury due to abrupt start of the machine, be sure to start the following work after turning the power off and ascertaining that the motor is at rest.

警告：

为了防止突然的起动造成的事故，请关掉电源后再进行操作。

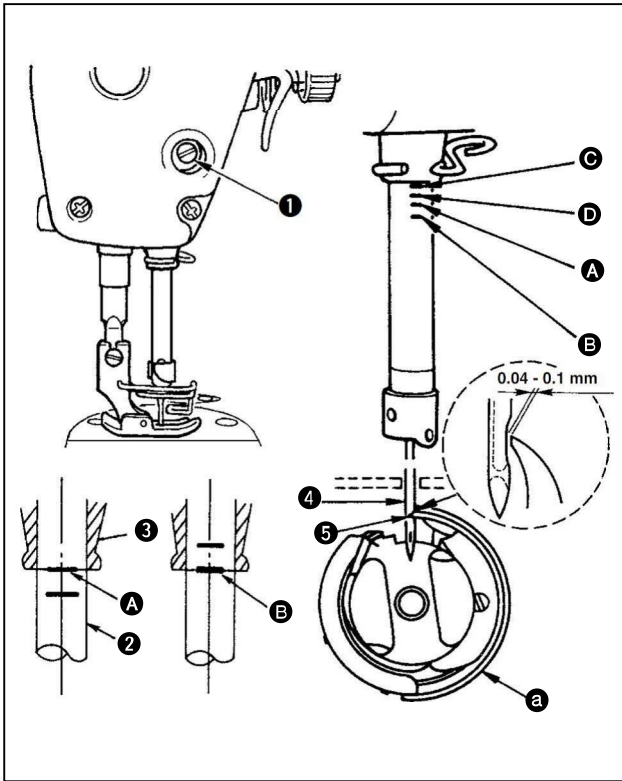

- 1) 转动飞轮，让针杆降到最下点，然后拧松针杆套管固定螺丝①。此时，请把送布调节盘的刻度对准0。（决定针杆高度）
- 2) 把针杆②的刻线A对准针杆下套③的下端，然后拧紧针杆套管固定螺丝①。（决定旋梭a的安装位置）
- 3) 拧松3颗旋梭固定螺丝，转动飞轮在针杆②上升的方向，把刻线B对准针杆下套③的下端。
- 4) 在此状态下，放旋梭尖⑤对准机针④的中心，把机针与旋梭的间隙调整为0.06-0.1（大致），然后拧紧螺丝。

### (1) Adjust the timing between the needle and the hook as follows :

- 1) Turn the handwheel to bring the needle bar down to the lowest point of its stroke, and loosen setscrew ①.

#### (Adjusting the needle bar height)

- 2) (For a DB needle) Align marker line A on needle bar ② with the bottom end of needle bar lower bushing ③, then tighten setscrew ①.  
(For a DA needle) Align marker line C on needle bar ② with the bottom end of needle bar lower bushing ③, then tighten setscrew ①.

#### (Adjusting position of the hook a)

- 3) (For a DB needle) Loosen the three hook setscrews, turn the handwheel and align marker line B on ascending needle bar ② with the bottom end of needle bar lower bushing ③.  
(For a DA needle) Loosen the three hook setscrews, turn the handwheel and align marker line D on ascending needle bar ② with the bottom end of needle bar lower bushing ③.
- 4) After making the adjustments mentioned in the above steps, align hook blade point ⑤ with the center of needle ④. Provide a clearance of 0.06 mm to 0.1 mm between the needle and the hook, then securely tighten setscrews in the hook.

## 17. ADJUSTING THE FEED TIMING / 送布相位的调节

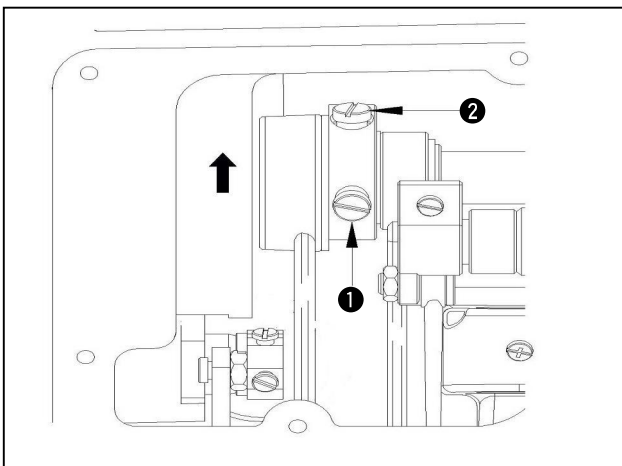

- 1) Set the feed regulating dial to 0.
- 2) As standard adjustment is performed as follows; Loosen setscrews ① and ②. Align the top of the needle and top surface of the feed dog with the top surface of the throat plate when the feed dog rises above the throat plate. Then securely tighten the setscrews.

- 1) 把送布调节刻度盘的刻度对准0.
- 2) 标准位置是，拧松固定螺丝①，②，让送布牙上升到针板上方，针尖和送布牙上面一致的位置，最后把固定螺丝拧紧。



## 18. HEIGHT OF THE FEED DOG/送布牙的高度



### WARNING :

To protect against possible personal injury due to abrupt start of the machine, be sure to start the following work after turning the power off and ascertaining that the motor is at rest.

### 警告：

为了防止突然的起动造成的事故，请关掉电源后再进行操作。

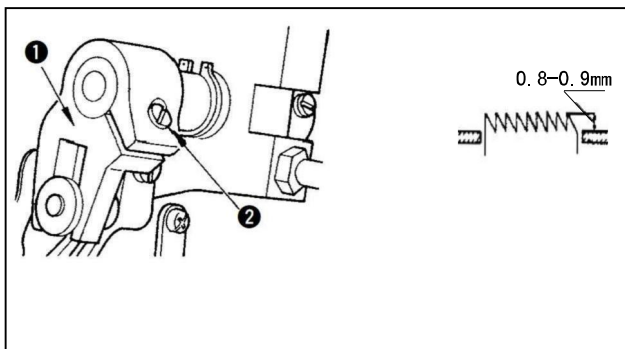

To adjust the height of the feed dog :

- ① Loosen screw ② of crank ①.
- ② Move the feed bar up or down to make adjustment.
- ③ Securely tighten screw ②.

送布牙高度的调节方法如下。

- 1) 拧松上下送布夹 ① 的固定螺丝 ②。
- 2) 上下移动送布台进行调节。
- 3) 拧紧固定螺丝 ②。

## 19. TILT OF THE FEED DOG/送布牙的倾斜度

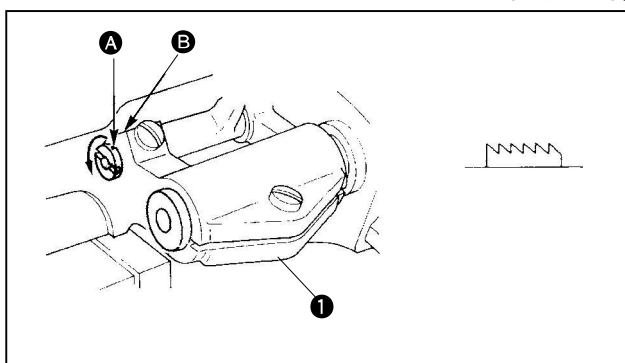

The standard tilt (horizontal) of the feed dog is obtained when marker dot A on the feed bar shaft is aligned with marker dot B on feed rocker ①.

标准的倾斜度（水平）为送布台轴上的刻度 A 与送布台曲柄 ① 的 B 部一致的位置。

## 20. REPLACING THE COUNTER KNIFE/固定刀更换

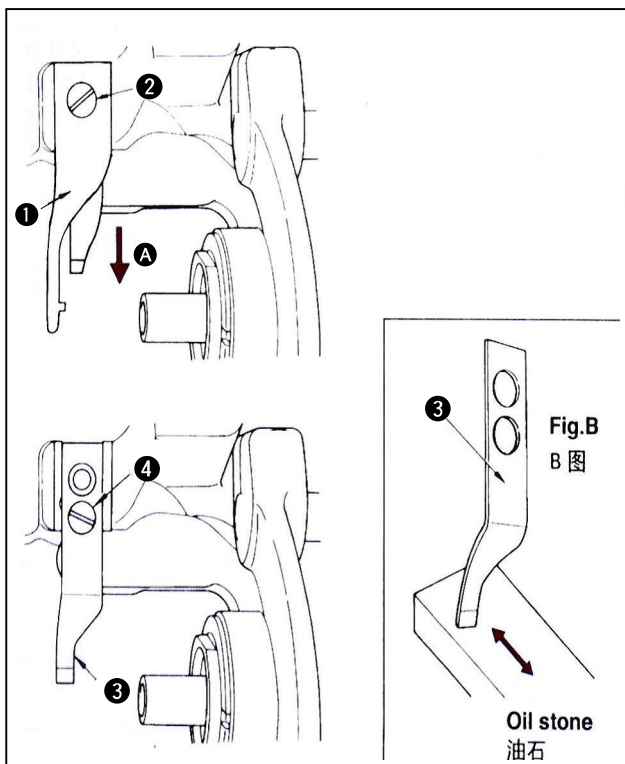

- 1) Loosen setscrew ② of bobbin case opening lever ① , and remove the bobbin case opening lever.
- 2) Loosen setscrew ④ ,and remove counter knife ③.
- 3) To install the counter knife, follow the above procedure in reverse order.
- 4) When attaching the bobbin case opening lever, tighten the serscrew while pressing the lever in direction A .

\* If the counter knife blade becomes blunt,grind counter knife blade ③ as shown in B using an oilstone.

- 1) 拧松旋梭定位勾 ① 的固定螺丝 ②，卸下旋梭定位勾。
  - 2) 拧松固定刀 ③ 的固定螺丝 ④，卸下固定刀。
  - 3) 安装固定刀时，请按相反的顺序进行操作。
  - 4) 安装旋梭定位勾时，一边向 A 方向推，一边把螺丝拧紧固定。
- \* 切刀切线不快时，请如图B所示那样研磨固定刀 ③。



## 21. PEDAL PRESSURE AND PEDAL STORE/踏板压力和行程调节



### WARNING

To protect against possible personal injury due to abrupt start of the machine, be sure to start the following work after turning the power off and ascertaining that the motor is at rest.

警告：

为了防止突然的起动造成的事故，请关掉电源后再进行操作。

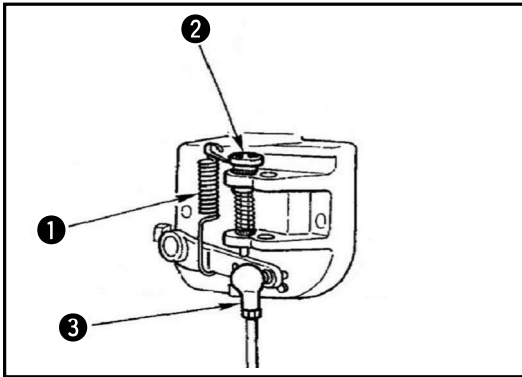

### 1. 踏板踩踏压力的调整

1) 调换踏板压力调节螺丝 ① 可以调节压力。

1. Adjusting the pressure required to depress the front part of the pedal

1) This pressure can be changed altering the mounting position of pedaling pressure adjust spring ①.

2. Adjusting the pressure required to depress the back part of pedal.

1) This pressure can be adjusted using regulator screw ②.

3. Adjusting the pedal stroke

1) The pedal stroke decreases when you insert connecting rod ③ into the left hole.

2. 踏板回踩里的调整

1) 用回踩调节螺丝 ② 可以进行调节。

3. 踏板踩踏行程的调节

1) 调换连杆 ③ 到左侧的孔后，行程变小。

## 22. ADJUSTMENT OF THE PEDAL/踏板调节

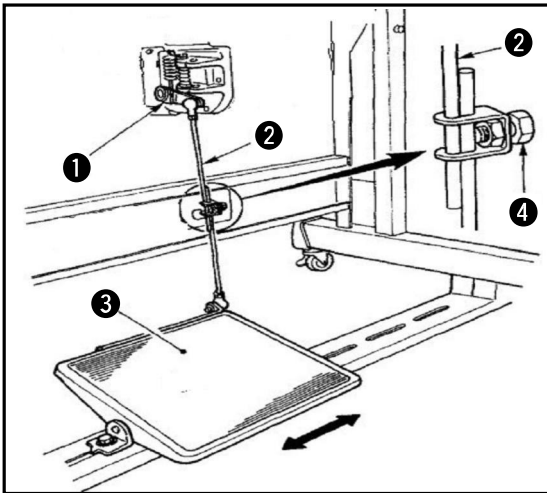

### 1. Installing the connection rod

Move pedal ③ to the right or left as illustrated by the arrows so that motor control lever ① and connecting rod ② are straightened.

### 2. Adjusting the pedal angle

1) The pedal tilt can be freely adjusted by changing the length of the connecting rod.

2) Loosen adjust screw ④, and adjust the length of connecting rod ②.

### 1. 联接杆的安装

把踏板调整板 ③ 沿箭头方向移动，让马达控制杆 ① 和联接杆 ② 成一直线。

### 2. 踏板角度

1) 调整联接杆的长度，可以自由地调整踏板的倾斜度。

2) 拧松调节螺丝 ④，拉出插进联接杆 ② 进行调整。

## 23. PEDAL OPERATION/踏板的操作

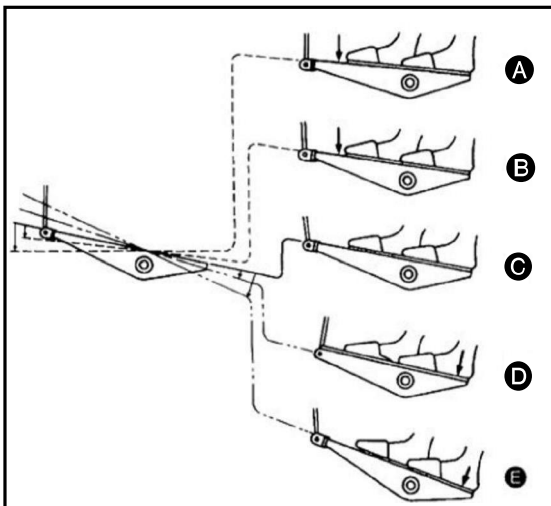

1) 轻轻向前踩踏板，为低速制 B。

2) 再继续向前踩踏板，则为高速制 A。

3) 把脚轻轻地放到踏板上稍微回踏一点，则停止缝制 C 缝制（机针上停止或下停止）

1) The machine runs at low sewing speed when you lightly depress the front part of the pedal B.

2) The machine runs at high sewing speed when you further depress the front part of the pedal A. (If the automatic reverse feed stitching has been preset, the machine runs at high speed after it completes reverse feed stitching.)

3) The machine stops (with its needle up or down) when you reset the pedal to its original position C.

4) The machine trims threads when you fully depress the back part of the pedal .

\* If your machine is provided with the Auto-lifter (AK series), an addition step is given between the machine stop and thread trimming step.

The presser foot goes up when you lightly depress the back part of the pedal D, and if you further depress the back part, the thread trimmer is actuated.

4) 强力向后踩踏板，即进行切线动作 E。

\* 使用自动压脚提升装置（AK 系列）时，在停止和切线档位之间增加一级开关。

往后轻轻踩踏板则提升压脚 D，再继续往后踩踏板则切线。

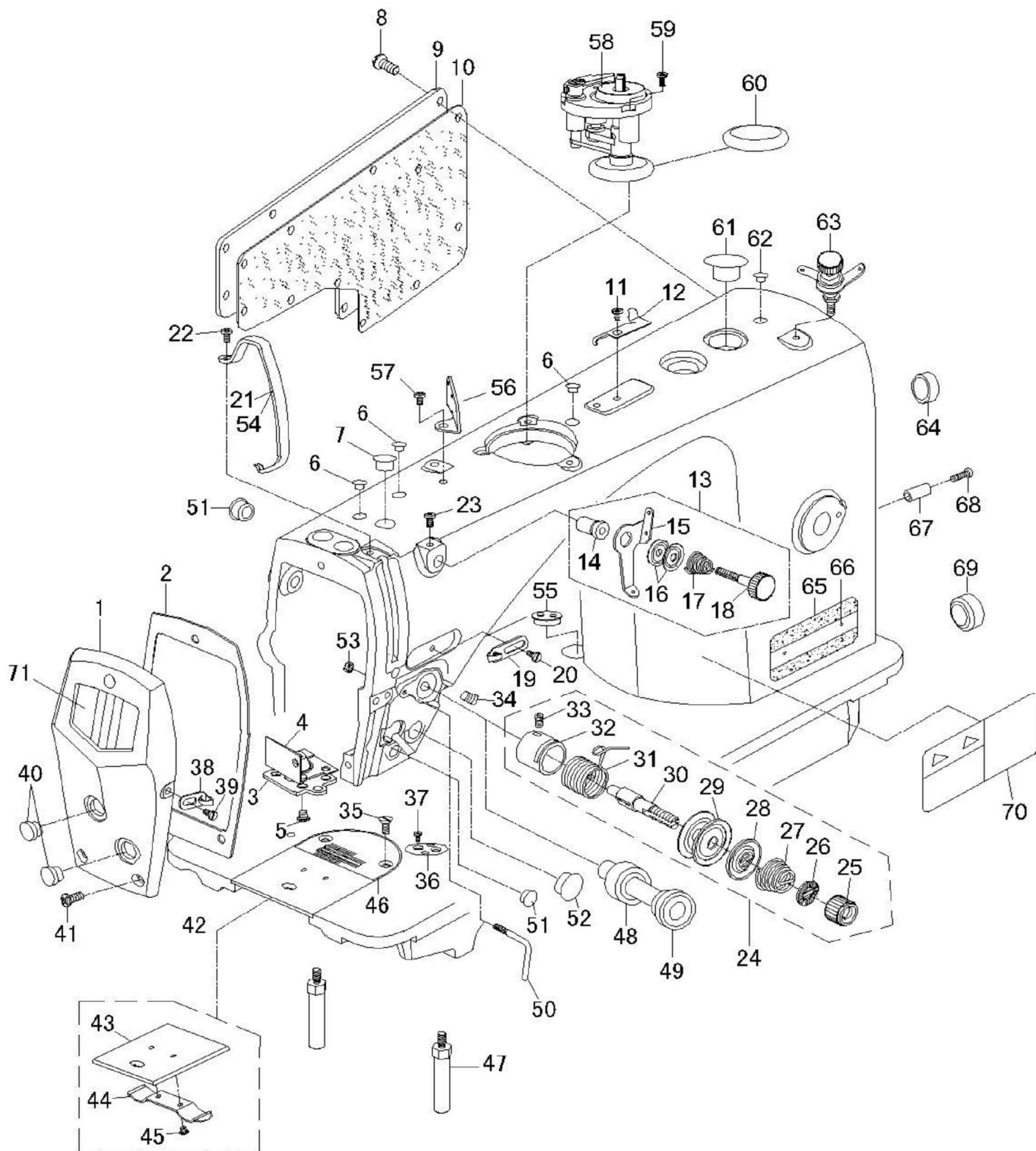

## 1.机壳分组件 MACHINE FRAME & MISCELLANEOUS COVER COMPONENTS

序号 NO	件号 Parts NO.	DESCRIPTION	名称	数量 Qty
1	G06-1-1	FACE PLATE ASM.	面板	1
2	G06-1-2	FACE PLATE GASKET	面板垫	1
3	G06-1-3	PRESSER BAR SUPPORT	针杆油封套固定板	1
4	G06-1-4	GASKET	针杆油封套	1
5	G06-1-5	SCREW 11/64- 40 L=7	螺钉11/64-40 L=7	4
6	G06-1-6	RUBBER PLUG	挑线连杆销螺孔塞	3
7	G06-1-7	RUBBER PLUG	针杆曲柄螺孔塞	1
8	G06-1-8	SCREW 3/16-28 L=9	后窗板螺钉3/16-28 L=9	10
9	G06-1-9	WINDOW PLATE	后窗板	1
10	G06-1-10	SIDE PLATE PACKING	后窗板垫	1
11	G06-1-11	SCREW 3/16-28 L=6	螺钉3/16-28 L=6	1
12	G06-1-12	KNIFE	割线刀	1
13	G06-1-13	THREAD TENSION ASM.NO.1	调线夹线器组件	1
14	G06-1-14	THREAD TENSION POST	调线夹线柱	(1)
15	G06-1-15	THREAD TENSION GUIDE	调线夹线板	(1)
16	G06-1-16	THREAD TENSION DISK	小夹线板	(2)
17	G06-1-17	THREAD TENSION SPRING	小夹线簧	(1)
18	G06-1-18	THREAD TENSION NUT	小夹线螺母	(1)
19	G06-1-19	ARM THREAD GUIDE A	右线钩	1
20	G06-1-20	SCREW	右线钩螺钉	1
21	G06-1-21	THRED TAKE-UP LEVER COVER	挑线杆防护罩	1
22	G06-1-22	SCREW 3/16-28 L=6	螺钉	1
23	G06-1-23	SCREW 3/16-28 L=6	螺钉	1
24	G06-1-24	THREAD TENSION ASM.	夹线器组件	1
25	G06-1-25	THREAD TENSION NUT	夹线螺母	(1)
26	G06-1-26	ROTATION STOPPER	夹线制动板	(1)
27	G06-1-27	THREAD TENSION SPRING A	夹线簧	(1)
28	G06-1-28	DISK STOPPER	夹线板	(1)
29	G06-1-29	THREAD TENSION DISK	夹线板	(2)
30	G06-1-30	THREAD TENSION POST	夹线螺钉	(1)
31	G06-1-31	THRED TAKE-UP SPRING	挑线簧	(1)
32	G06-1-32	THREAD TENSION POST BASE	挑线簧调节座	(1)
33	G06-1-33	SCREW 9/64-40 L=5.5	夹线螺钉紧固螺钉9/64-40 L=5.5	(1)
34	G06-1-34	SCREW 15/64-28 L=7	夹线器螺钉15/64-28 L=7	1
35	G06-1-35	SCREW 11/64-40 L=8.5	针板螺钉11/64-40 L=8.5	2
36	G06-1-36	RULER PLATE	限位挡片	1
37	G06-1-37	RULER PLATE SCREW	限位挡片螺钉	2
38	G06-1-38	ARM THREAD GUIDE B	左线钩	1
39	G06-1-39	SCREW 11/64-40 L=6	左线钩螺钉11/64-40 L=6	1
40	G06-1-40	RUBBER PLUG D=12.5 L=4	面板调节螺钉塞	2
41	G06-1-41	SCREW 3/16-28 L=10	面板螺钉	3
42	G06-1-42	SIDE PLATE ASM	推板部件	1
43	G06-1-43	SIDE PLATE	推板	(1)

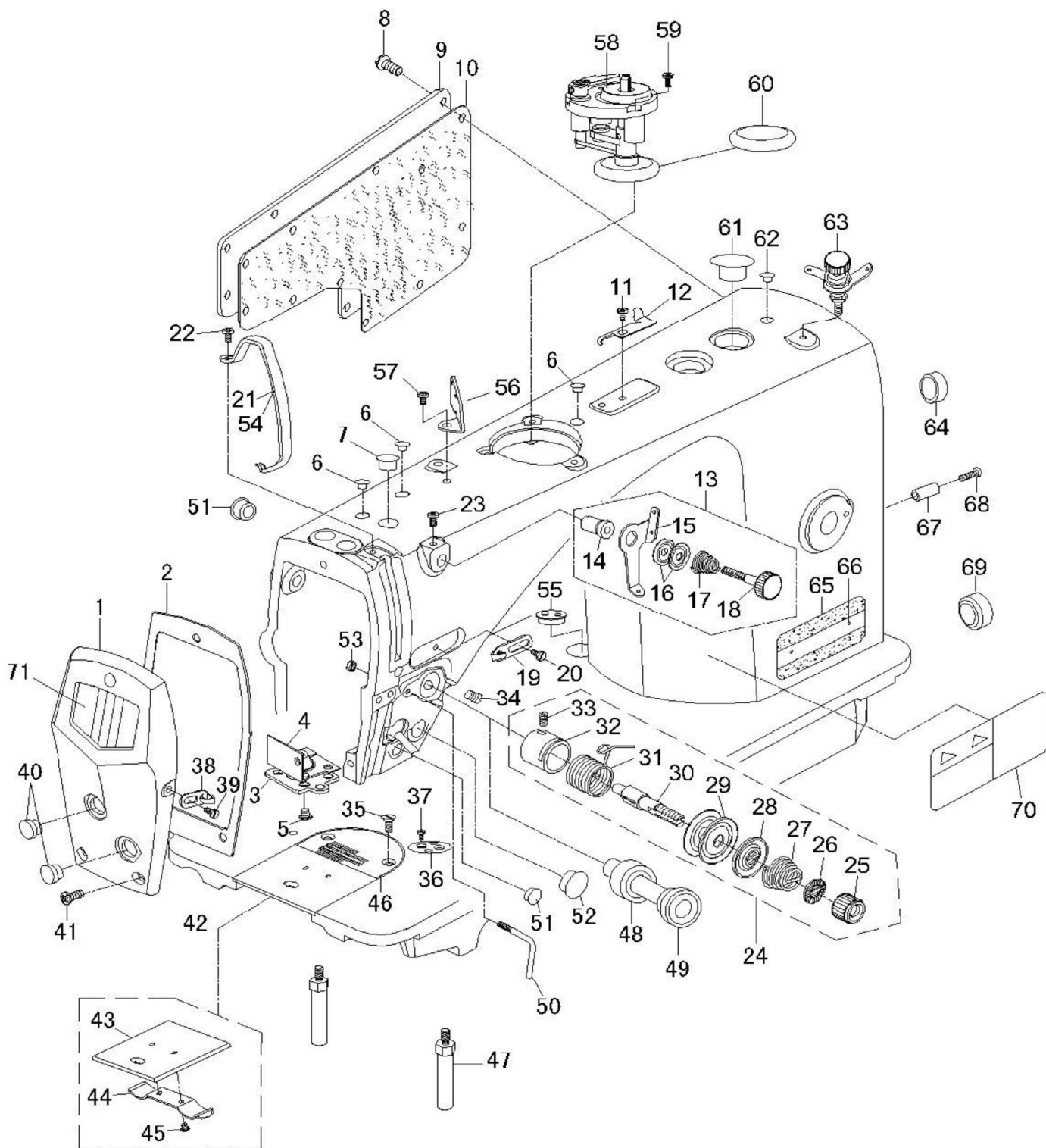

## 1.机壳分组件 MACHINE FRAME & MISCELLANEOUS COVER COMPONENTS

序号 NO	件号 Parts NO.	DESCRIPTION	名称	数量 Qty
44	G06-1-44	SIDE PLATE SPRING	推板簧	(1)
45	G06-1-45	SCREW 3/32-58 L=1.9	推板簧螺钉	(2)
46	G06-1-46	THROAT PLATE	针板	1
47	G06-1-47	BED SCREW STUD	底板支柱	4
48	G06-1-48	TENSION RELEASE PIN CAP ASM.	松线钉帽组件	1
49	G06-1-49	CAP RING	松线钉	1
50	G06-1-50	ARM THREAD GUIDE C	C型线钩	1
51	G06-1-51	RUBBER PLUG	橡皮塞	2
52	G06-1-52	RUBBER PLUG	橡皮塞	1
53	G06-1-53	NUT 11/64-40	螺母	1
54	G06-1-54	THRED TAKE-UP LEVER COVER	挑线杆防护罩	1
55	G06-1-55	RUBBER BUSHING	过线套	1
56	G06-1-56	THREAD RETAINER	三孔线勾	1
57	G06-1-57	SCREW 3/16-28 L=6	螺钉3/16-28 L=6	1
58	G06-1-58	BOBBIN BASE ASM	绕线器组件	1
59	G06-1-59	SCREW 3/16-32 L=8	螺钉3/16-28 L=8	3
60	G06-1-60	RUBBERING	绕线器橡胶圈	1
61	G06-1-61	RUBBER PLUG	橡皮塞	1
62	G06-1-62	RUBBER PLUG	橡皮塞	1
63	G06-1-63	THREAD TENSION ASM.	绕线小夹线器组件	1
64	G06-1-64	RUBBER PLUG	橡皮塞	1
65	G06-1-65	MODEL PLATE	型号牌	1
66	G06-1-66	POLE	型号牌铆钉	2
67	G06-1-67	LEVER STOPPER ASM	扳手限位支架组件	1
68	G06-1-68	SCREW 3/16-28	扳手限位支架组件螺钉	1
69	G06-1-69	RUBBER PLUG	下轴盲孔橡皮塞	1
70	G06-1-70	ATTENTION SEAL	安全指示牌	1
71	G06-1-71	PLATE	商标牌	1

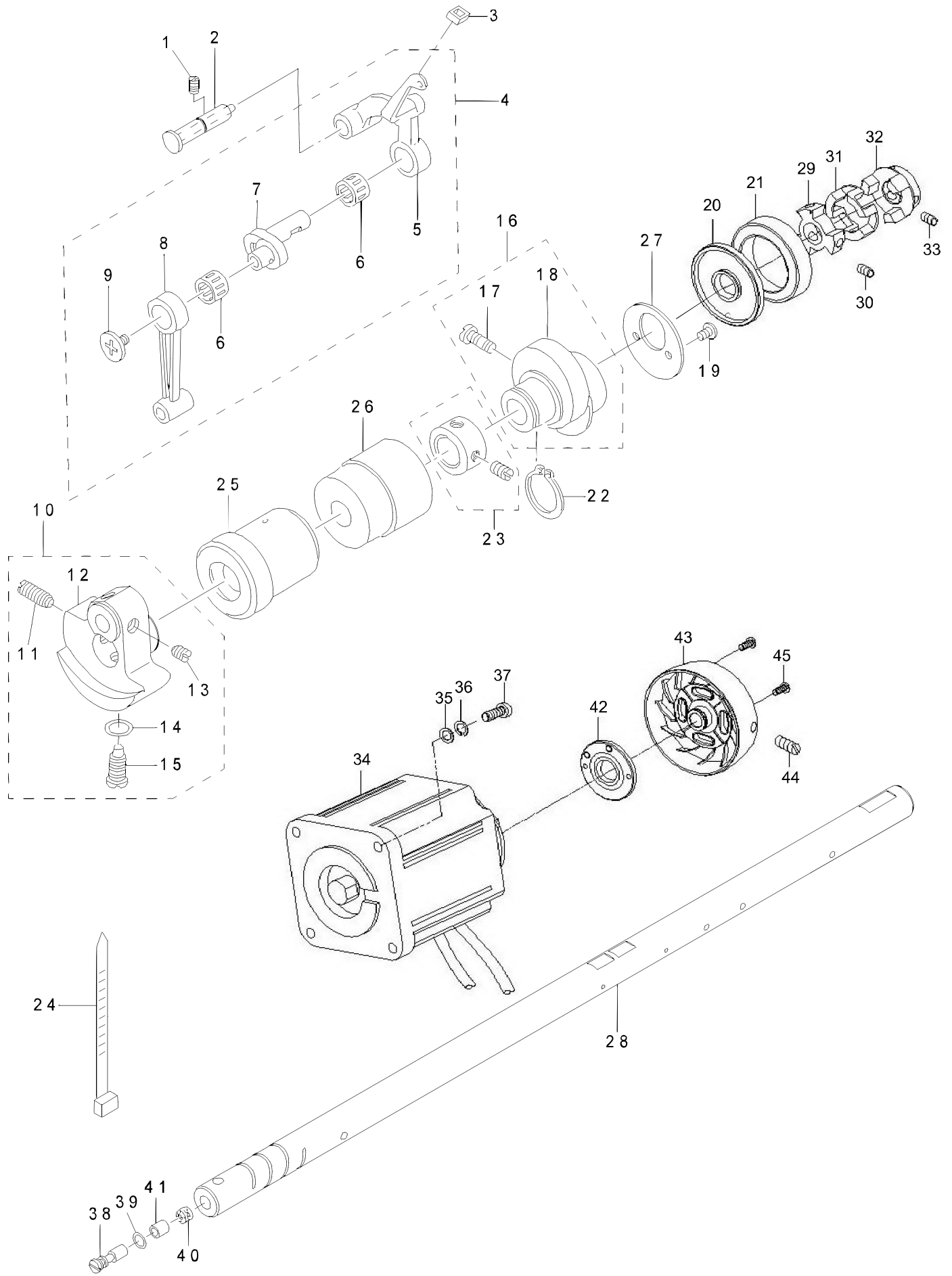



## 2.上轴分组件 MAIN SHAFT COMPONENTS

序号 NO	件号 Parts NO.	DESCRIPTION	名称	数量 Qty
1	G06-2-1	SCREW 15/64-28 L=10.5	挑线连杆销螺钉	1
2	G06-2-2	THRED TAKE-UP CRANK SHAFT ASM.	挑线连杆销	1
3	G06-2-3	OIL PROTECTING RUBBER	防油胶套	1
4	G06-2-4	THRED TAKE-UP LEVER ASM.	挑线杆组件	1
5	G06-2-5	THRED TAKE-UP LEVER ASM.	挑线连杆分组件	(1)
6	G06-2-6	NEEDLE BEARING	挑线杆滚针轴承	(2)
7	G06-2-7	NEEDLE BAR CRANK	挑线曲柄部件	(1)
8	G06-2-8	NEEDLE BAR CRANK ROD	针杆连杆	(1)
9	G06-2-9	LEFT SCREW	挑线曲柄左旋螺钉	(1)
10	G06-2-10	COUNTER WEIGHT ASM.	针杆曲柄组件	1
11	G06-2-11	SCREW 9/32-28 L=16	针杆曲柄紧固螺钉	(1)
12	G06-2-12	COUNTER WEIGHT	针杆曲柄	(1)
13	G06-2-13	SCREW 1/4-40 L=6	挑线曲柄定位螺钉	(2)
14	G06-2-14	RUBBER RING	定位螺钉O型圈	(1)
15	G06-2-15	SCREW 9/32-28 L=16	针杆曲柄定位螺钉	(1)
16	G06-2-16	FEED DRIVE ECCENTRIC CAM ASM.	送料偏心轮组件	1
17	G06-2-17	SCREW 1/4-40 L=11	送料偏心轮螺钉	(2)
18	G06-2-18	FEED DRIVE ECCENTRIC CAM	送料偏心轮	(1)
19	G06-2-19	SCREW 9/64-40 L=6	送料偏心轮盖板螺钉	2
20	G06-2-20	OIL SEAL	上轴封油套	1
21	G06-2-21	MAIN SHAFT BUSHING REAR	轴承	1
22	G06-2-22	SNAP RING 18.5	拾牙连杆轴挡圈	1
23	G06-2-23	MAIN SHAFT THRUST COLLAR ASM.	上轴挡圈组件	1
24	G06-2-24	CABLE BAND	电线夹	1
25	G06-2-25	BUSHING FRONT	上轴前轴套	1
26	G06-2-26	BUSHING INTERMEDIATE	上轴中轴套	1
27	G06-2-27	THRUST COLLAR	送料偏心轴盖板	1
28	G06-2-28	MAIN SHAFT	上轴	1
29	G06-2-29	CLUTCH COMPONENT (A)	离合器 (A)	1
30	G06-2-30	SCREW M6 L=8	螺钉	3
31	G06-2-31	ALNICO TRAY	离合器橡胶垫	1
32	G06-2-32	CLUTCH COMPONENT (B)	离合器 (B)	1
33	G06-2-33	SCREW M6 L=6	螺钉	3
34	G06-2-34	AC CERVO MOTOR	AC伺服马达	1
35	G06-2-35	WASHER	垫片	4
36	G06-2-36	SPRING WASHER	弹性垫片	4
37	G06-2-37	SCREW M5 L=20	电机固定螺钉	4
38	G06-2-38	OIL ADJUSTING PIN	上轴油量调节销	1
39	G06-2-39	RUBBER RING	上轴油量调节销O型圈	1
40	G06-2-40	ROLLER FELT	曲柄油量限制毯	1
41	G06-2-41	OIL ADJUSTING COLLAR	曲柄油量调节销	1
42	G06-2-42	MAGNETS	磁钢	1
43	G06-2-43	GAND WHEEL	手轮	1
44	G06-2-44	SCREW 11/64-40 L=8	手轮固定螺钉	2
45	G06-2-45	SCREW M5 L=10	磁钢固定螺钉	2

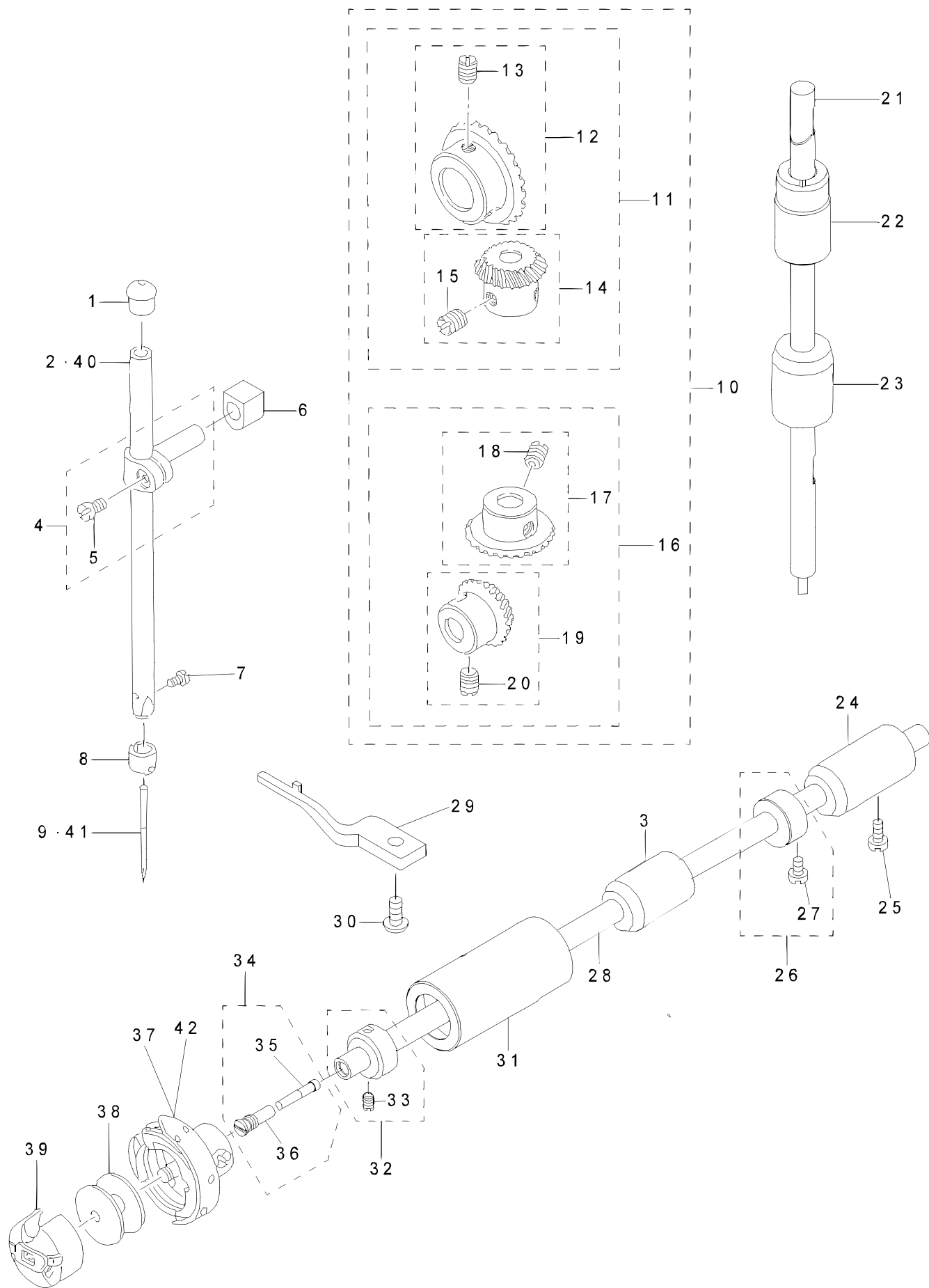

### 3.针杆、竖轴及旋梭驱动轴分组件 NEEDLE BAR,UPRIGHT SHAFT & HOOK DRIVING SHAFT COMPONENTS

序号 NO	件号 Parts NO.	DESCRIPTION	名称	数量 Qty
1	G06-3-1	RUBBER PLUG	针杆上孔塞	1
2	G06-3-2	NEEDLE BAR A	针杆	1
3	G06-3-3	HOOK DRIVING SHAFT BUSH MIDDLE	下轴中轴套	1
4	G06-3-4	NEEDLE BAR HOLDER ASM.	针杆连接柱组件	1
5	G06-3-5	SCREW 9/64-40 L=6	针杆连接柱螺钉	(1)
6	G06-3-6	SLIDE BLOCK	针杆连接柱滑块	1
7	G06-3-7	SCREW 1/8-44 L=4.5	机针螺钉	1
8	G06-3-8	NEEDLE THREAD GUIDE A	机针线钩	1
9	G06-3-9	NEEDLE DBX5 #14	机针	1
10	G06-3-10	GEAR & PINION ASM.	伞齿轮组件	1
11	G06-3-11	GEAR & PINION ASM.UPPER	上齿轮组件	(1)
12	G06-3-12	GEAR ASM.	上伞齿轮组件	(1)
13	G06-3-13	SCREW 1/4-40 L=8	伞齿轮螺钉	(2)
14	G06-3-14	PINION ASM.	竖轴上伞齿轮组件	(1)
15	G06-3-15	SCREW 1/4-40 L=8	伞齿轮螺钉	(2)
16	G06-3-16	GEAR & PINION ASM.LOWER	下齿轮组件	(1)
17	G06-3-17	GEAR ASM.LOWER	竖轴下齿轮组件	(1)
18	G06-3-18	SCREW 1/4-40 L=8	伞齿轮螺钉	(2)
19	G06-3-19	PINION ASM.	下轴伞齿轮组件	(1)
20	G06-3-20	SCREW 1/4-40 L=8	伞齿轮螺钉	(2)
21	G06-3-21	UPRIGHT SHAFT	竖轴	1
22	G06-3-22	UPRIGHT SHAFT BUSHING UPPER	竖轴上轴套	1
23	G06-3-23	UPRIGHT SHAFT BUSHING LOWER	竖轴下轴套	1
24	G06-3-24	HOOK DRIVING SHAFT BUSH REAR	下轴后轴套	1
25	G06-3-25	SCREW 15/64-28 L=6	下轴后轴套螺钉	1
26	G06-3-26	THREAD COLLAR ASM.REAR	下轴挡圈组件	1
27	G06-3-27	SCREW 11/64-40 L=4.8	下轴挡圈螺钉	(2)
28	G06-3-28	HOOK DRIVING SHAFT	下轴	1
29	G06-3-29	BOBBIN CASE HOLDER	旋梭定位钩	1
30	G06-3-30	SCREW 11/64-40 L=9	旋梭定位钩螺钉	1
31	G06-3-31	HOOK DRIVING SHAFT BUSH FRONT	下轴前轴套	1
32	G06-3-32	THREAD COLLAR ASM.FRONT	下轴挡油圈组件	1
33	G06-3-33	SCREW 11/64-40 L=3.5	下轴挡油圈螺钉	(2)
34	G06-3-34	OIL SEAL SCREW ASM.	下轴限油组件	1
35	G06-3-35	OIL WICK	下轴限油芯	(1)
36	G06-3-36	SET SCREW	下轴限油螺钉	(1)
37	G06-3-37	HOOK ASM.	旋梭	1
38	G06-3-38	BOBBIN	梭心	1
39	G06-3-39	BOBBIN CASE ASM.	梭壳	1
40	G06-3-40	NEEDLE BAR B	针杆	1
41	G06-3-41	NEEDLE 134 90	机针	1
42	G06-3-42	HOOK ASM.	旋梭	1

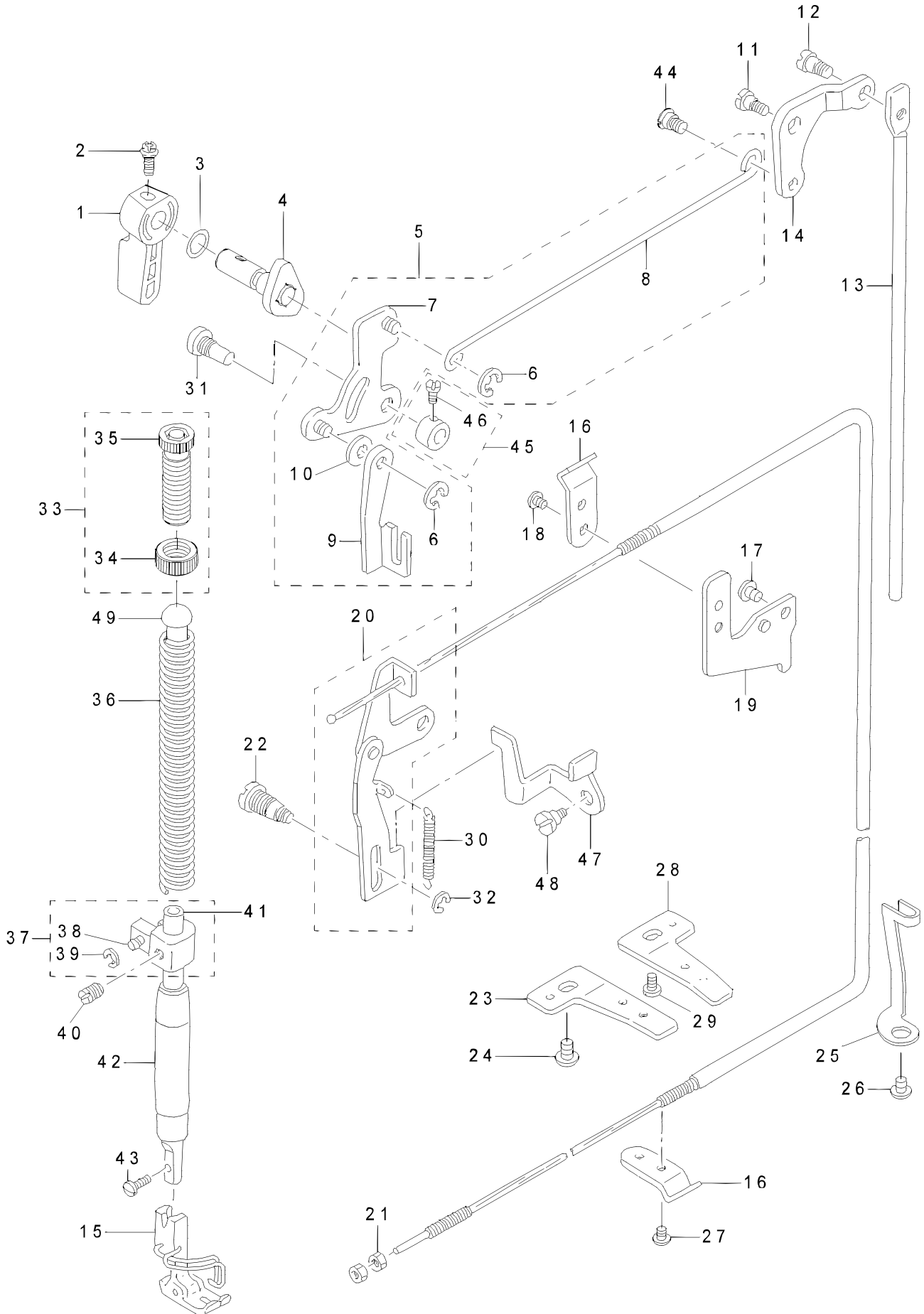

#### 4.压脚分组件 HAND LIFTER COMPONENTS

序号 NO	件号 Parts NO.	DESCRIPTION	名称	数量 Qty
1	G06-4-1	HAND LIFTER	压脚扳手	1
2	G06-4-2	SCREW	压脚扳手螺钉	1
3	G06-4-3	RUBBER RING	压脚扳手凸轮O型圈	1
4	G06-4-4	HAND LIFTER CAM ASM.	压脚扳手凸轮部件	1
5	G06-4-5	LIFTER LEVER ASM.	前杠杆组件	1
6	G06-4-6	E-RING	挡圈	(2)
7	G06-4-7	LIFTER LEVER ASM.	调压脚前杠杆部件	(1)
8	G06-4-8	KNEE LIFTER SIDE ROD	抬压脚拉杆	(1)
9	G06-4-9	LIFTER LEVER	压脚升降板	(1)
10	G06-4-10	WASHER 6.5*13*0.8	压脚升降板垫圈	(1)
11	G06-4-11	HINGE SCREW D=7.24 H=3.3	后杠杆轴拉螺钉	1
12	G06-4-12	HINGE SCREW D=6 H=3.2	抬压脚顶杆螺钉	1
13	G06-4-13	CONNECTING ROD	抬压脚顶杆	1
14	G06-4-14	LIFTING LEVER LINK	抬压脚后杠杆	1
15	G06-4-15	PRESSER FOOT ASM.	活压脚部件	1
16	G06-4-16	WIRE PRESSER A	拉线活压板	2
17	G06-4-17	SCREW 3/16-28 L=6	上压板组件紧固螺钉	1
18	G06-4-18	SCREW 11/64-40 L=5	上压板紧固螺钉	1
19	G06-4-19	WIRE PRESSER BASE UPPER	上压线底板	1
20	G06-4-20	WIRE CABLE ASM.	松线顶板组件	1
21	G06-4-21	NUT 3/16-32	拉线扭矩调节螺母	2
22	G06-4-22	TENSION RELEASE PLATE SHAFT	松线顶板螺纹销	1
23	G06-4-23	WIRE PRESSER BASE LOWER	左下压线底板	1
24	G06-4-24	SCREW 11/64-28 L=9	下压板组件紧固螺钉	1
25	G06-4-25	WIRE CABLE HOLDER	挡线板	1
26	G06-4-26	SCREW 3/16-28 L=6	螺钉	1
27	G06-4-27	SCREW 11/64-40 L=5	拉线活压板螺钉	1
28	G06-4-28	WIRE PRESSER PLATE B	右下压线底板	1
29	G06-4-29	SCREW 11/64-40 L=7	下压板组件紧固螺钉	1
30	G06-4-30	SPRING	松线顶板复位簧	1
31	G06-4-31	LINK SHAFT	前杠杆螺纹销	1
32	G06-4-32	E-RING	螺纹销开口挡圈	1
33	G06-4-33	PRESSER SPRING REG NUT AMS.	调压组件	1
34	G06-4-34	PRESSER SPRING REGULATOR NUT	调压螺母	(1)
35	G06-4-35	PRESSER SPRING REGULATOR	调压螺钉	(1)
36	G06-4-36	PRESSER SPRING	调压簧	1
37	G06-4-37	NEEDLE BAR GUIDE BRACKET ASM.	压杆导架组件	1
38	G06-4-38	PIN	定位销	(1)
39	G06-4-39	E-RING 3	挡圈	(2)
40	G06-4-40	SCREW 1/4-40 L=6	压杆倒架螺钉	1
41	G06-4-41	PRESSER BAR	压杆	1
42	G06-4-42	PRESSER BAR BUSHING LOWER	压杆轴套	1
43	G06-4-43	SCREW 9/64-40 L=10.5	活压脚螺钉	1
44	G06-4-44	HINGE SCREW	活压脚压杆螺钉	1
45	G06-4-45	THRUST COLLAR ASM.	紧圈组件	1
46	G06-4-46	SCREW 9/64-40 L=6.1	紧圈螺钉	(1)
47	G06-4-47	TENSION RELEASE LINK A	松线铺板	1
48	G06-4-48	HINGE SCREW D=3.65 H=2.6	松线铺板螺钉	1
49	G06-4-49	PRESSER GUIDE BAR	调压导杆	1

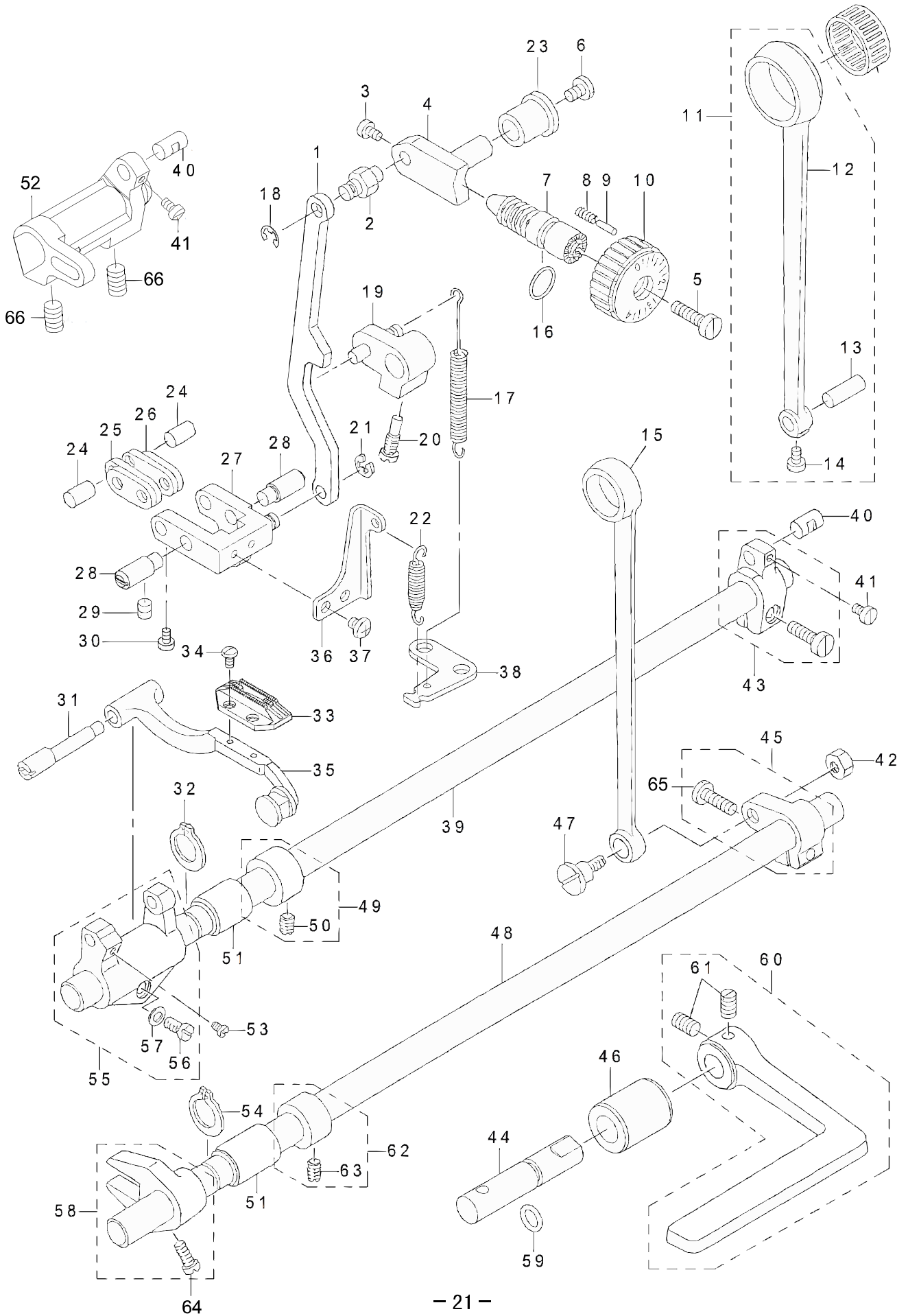



## 5.送料分组件 FEED MECHANISM COMPONENTS

序号 NO	件号 Parts NO.	DESCRIPTION	名称	数量 Qty
1	G06-5-1	FEED ADJUST ROD	倒送料连杆	1
2	G06-5-2	FEED REGULATOR BASE PIN	倒送料连杆销	1
3	G06-5-3	SCREW SM9/64-40 L=6	连杆销螺钉SM9/64x40 L=6	2
4	G06-5-4	FEED REGULATOR BUSHING	送料调节器	1
5	G06-5-5	SCREW 3/16-28 L=18	送料距旋钮螺钉	1
6	G06-5-6	SCREW 3/16-28 L=7	送料调节器轴	1
7	G06-5-7	FEED REGULATOR SCREW	送料调节螺栓	1
8	G06-5-8	FEED REGULATOR PIN SPRING	送料距锁合簧	1
9	G06-5-9	FEED REGULATOR PIN	送料距锁合销	1
10	G06-5-10	FEED DIAL	送料距旋钮	1
11	G06-5-11	ROCKER SHAFT CONNECTING ROD ASM	送料连杆组件	1
12	G06-5-12	ROCKER SHAFT CONNECTING ROD	送料连杆	(1)
13	G06-5-13	WALKING FOOT PIN C	送料连杆销	(1)
14	G06-5-14	SCREW 9/64- 40 L=6	送料连杆销螺钉	(1)
15	G06-5-15	CONNECTING ROD	抬牙连杆	1
16	G06-5-16	RUBBER RING	送料调节螺栓O型圈	1
17	G06-5-17	SPRING	倒送料拉簧	1
18	G06-5-18	E-RING	倒送料连杆销挡圈	1
19	G06-5-19	FEED REVERSE ARM ASM.	倒送料曲柄组件	1
20	G06-5-20	SCREW 3/16-28 L=14	倒送料曲柄螺钉	(1)
21	G06-5-21	E-RING	倒送料连杆挡圈	1
22	G06-5-22	SPRING	摆动板座复位簧	1
23	G06-5-23	FEED REGULATOR BUSHING	送料调节器轴套	1
24	G06-5-24	PIN	摆动板座连接销	2
25	G06-5-25	CONNECTING LINK A	送料长摆动板	2
26	G06-5-26	CONNECTING LINK B	送料短摆动板	2
27	G06-5-27	FEED ADJUST LINK ASM.	送料摆动板座组件	1
28	G06-5-28	ADJUSTING INK SHAFT	送料摆动板座左右销	2
29	G06-5-29	SCREW SM15/64-28 L=7	左右销螺钉	2
30	G06-5-30	SCREW SM9/64-40 L=6	连杆销螺钉	2
31	G06-5-31	FEED BAR SHAFT	牙架销	1
32	G06-5-32	RETAINING RING 13.8	送料轴轴用挡圈	1
33	G06-5-33	FEED DOG	送料牙	1
34	G06-5-34	SCREW SM1/8-44 L=6	送料牙螺钉	2
35	G06-5-35	FEED BAR ASM	牙架部件	1
36	G06-5-36	REGULATOR LINK SPRING HOOK	摆动板座复位簧固定板	1
37	G06-5-37	SCREW SM11/64-40 L=5	螺钉	2
38	G06-5-38	FEED SPRING HOOK	拉簧固定板	1
39	G06-5-39	FEED ROCKER SHAFT	送料轴	1
40	G06-5-40	WALKING FOOT PIN B	送料曲柄销	1
41	G06-5-41	SCREW SM9/64-40 L=6	曲柄销螺钉	1
42	G06-5-42	NUT 9/32-40 L=6	抬牙连杆轴螺母	1
43	G06-5-43	FEED ROCKER SHAFT CRANK	送料曲柄	1
44	G06-5-44	REVERSE FEED SHAFT	倒送料轴	1

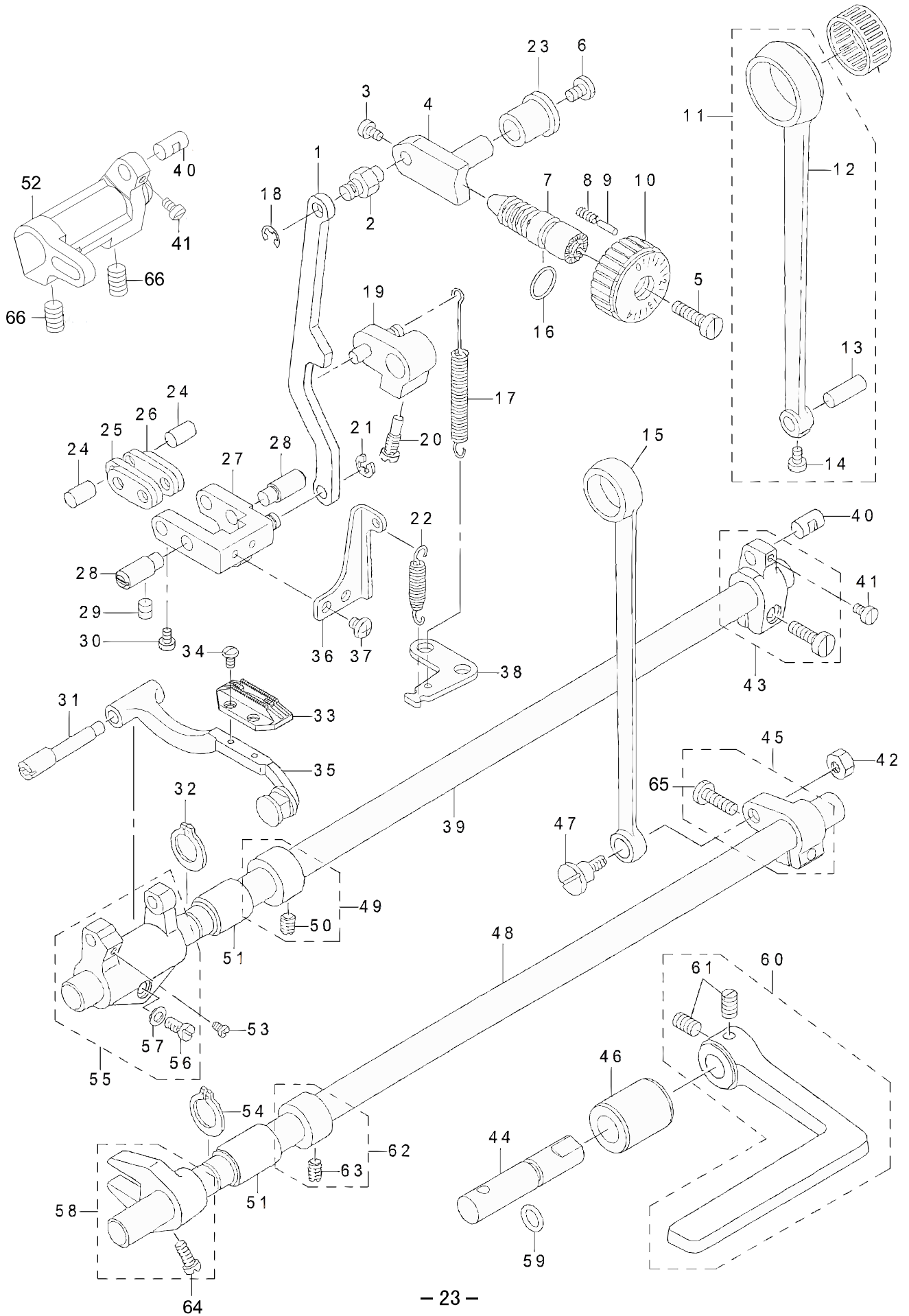

## 5.送料分组件 FEED MECHANISM COMPONENTS

序号 NO	件号 Parts NO.	DESCRIPTION	名称	数量 Qty
45	G06-5-45	LIFTING ROCKER	拾牙后曲柄	1
46	G06-5-46	BUSHING	倒送料轴轴套	1
47	G06-5-47	SCREW	拾牙连杆轴位螺钉	1
48	G06-5-48	FEED DRIVING SHAFT	拾牙轴	1
49	G06-5-49	THRUST COLLAR	送料轴挡圈	1
50	G06-5-50	SCREW SM1/4-40 L=6	送料轴挡圈螺钉	2
51	G06-5-51	FEED ROCKER SHAFT BUSHING	拾牙送料轴前轴套	2
52	G06-5-52	FEED ROCKER SHAFT CRANK	送料曲柄	1
53	G06-5-53	SCREW SM11/64-40 L=7	牙架销螺钉	1
54	G06-5-54	RETAINING RING 13.8	拾牙轴轴用挡圈	1
55	G06-5-55	FEED BAR DRIVING CRANK	牙架座	1
56	G06-5-56	SCREW SM3/16-28 L=14	牙架座螺钉	1
57	G06-5-57	WASHER	垫圈	1
58	G06-5-58	LIFTING FORK	拾牙叉形曲柄	1
59	G06-5-59	RUBBER RING	倒送料轴O形圈	1
60	G06-5-60	REVERSE FEED CONTROLLEVER	倒送料扳手	1
61	G06-5-61	SCREW SM1/4-40 L=8	倒送料扳手螺钉	2
62	G06-5-62	THRUST COLLAR	拾牙轴挡圈	1
63	G06-5-63	SCREW SM1/4-40 L=6	拾牙轴挡圈螺钉	2
64	G06-5-64	SCREW SM11/64-40 L=10.5	拾牙叉形曲柄螺钉	1
65	G06-5-65	SCREW SM3/16-28 L=15.5	拾牙后曲柄螺钉	1
66	G06-5-66	SCREW SM9/32-28 L=10	送料曲柄螺钉	2

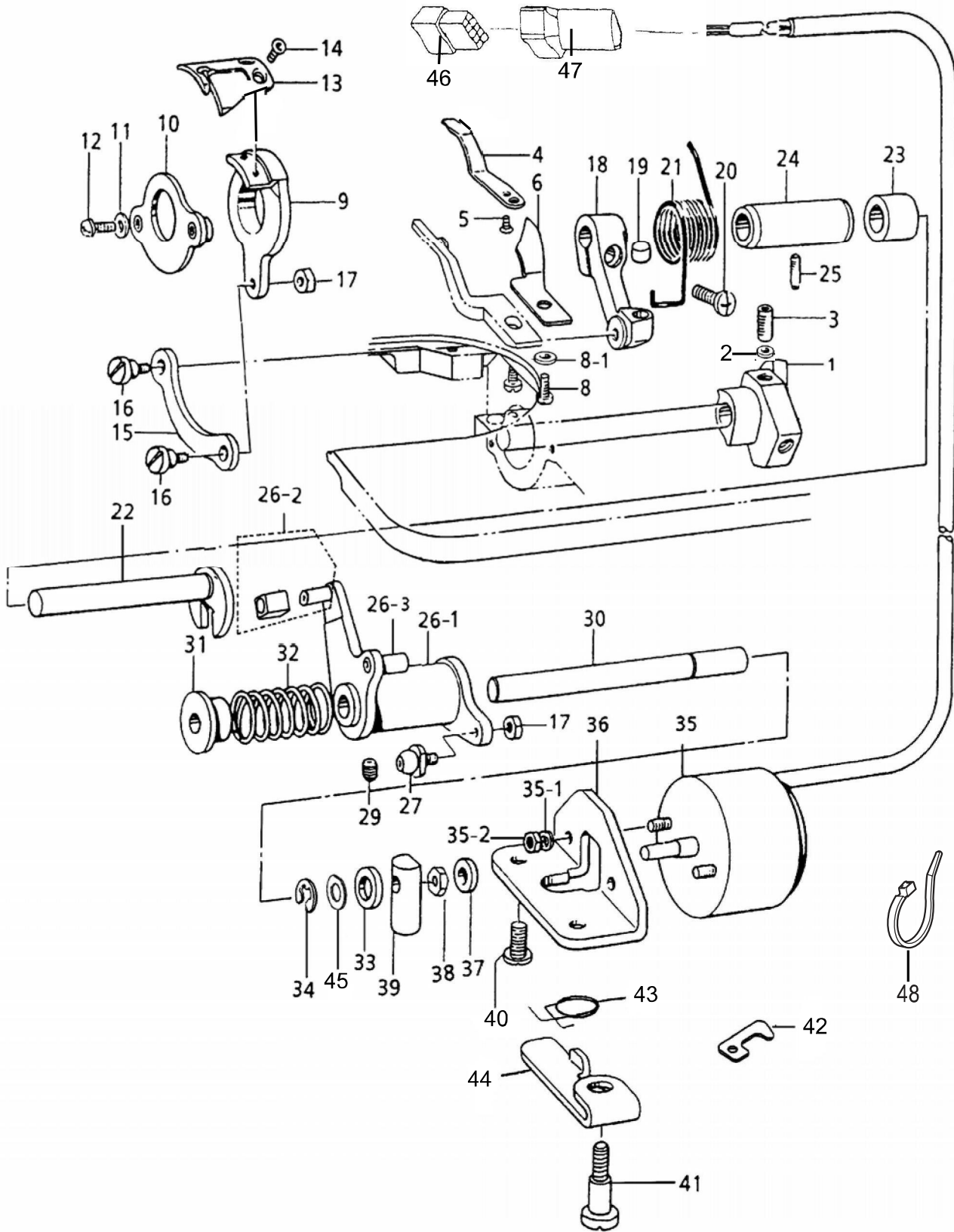

## 6.自动切线 THREAD TRIMMER COMPONENTS

序号 NO	件号 Parts NO.	DESCRIPTION	名称	数量 Qty
1	G06-6-1	THREAD SHEAR CAM	切线凸轮	1
2	G06-6-3	SCREW	螺钉	1
3	G06-6-4	SECANT KNIFE	固定刀	1
4	G06-6-5	SCREW	螺钉	1
5	G06-6-6	PROTECT NEEDLE PATCH	分线器	1
6	G06-6-7	WASHER	分线器螺钉垫片	1
7	G06-6-8	SCREW	螺钉	1
8	G06-6-9	KNIFE BRACKET	剪线刀架	1
9	G06-6-10	PARTIALITY SHANK ASM.	刀架压板	1
10	G06-6-11	WASHER	刀架压板螺钉垫片	2
11	G06-6-12	SCREW	螺钉	2
12	G06-6-13	MOTORIAL KNIFE	活动刀	1
13	G06-6-14	SCREW	螺钉	2
14	G06-6-15	KNIFE SHAFT CONNECTING ROD	刀轴连杆	1
15	G06-6-16	SCREW	螺钉	2
16	G06-6-17	NUT	螺母	2
17	G06-6-18	THREAD SHEAR ROCK CRANK	切刀驱动曲柄	1
18	G06-6-19	POSITIONING BLOCK	驱动曲柄止动块	1
19	G06-6-20	SCREW	螺钉	1
20	G06-6-21	SORING	弹簧	1
21	G06-6-22	THREAD SHEAR ROCK ARM SHAFT	切刀驱动曲柄轴	1
22	G06-6-23	SHORT BUSH	驱动曲柄轴短套	1
23	G06-6-24	THREAD SHEAR CAM BUSHING	切线轴套	1
24	G06-6-25	SCREW	螺钉	1
25	G06-6-26-1	THREAD SHEAR ROCK ARM SHAFT	切线凸轮曲柄	1
26	G06-6-26-2	SLIPPERY PIECE SHAFT ASM.	滑块轴组件	1
27	G06-6-26-3	LIMIT POTENTIAL SHAFT	切线限位轴	1
28	G06-6-27	ROLL SHAFT ASM.	滚柱轴组件C	1
29	G06-6-29	SCREW	螺钉	1
30	G06-6-30	THREAD SHEAR SHAFT	切刀驱动轴	1
31	G06-6-31	SPRING COVER	扭簧端盖	1
32	G06-6-32	SPRING	切线凸轮复位弹簧	1
33	G06-6-33	MAGNETIC PLUG CUSHION MAT	电磁铁缓冲垫	1
34	G06-6-34	E-RING	E挡圈	1
35	G06-6-35	THREAD TRIMMER SOLENOID	切线电磁铁	1
36	G06-6-35-1	SPRING WASHER	切线电磁铁弹垫	2
37	G06-6-35-2	NUT	螺母	2
38	G06-6-36	RTHREAD TRIMMER SOLENOID BASE	切线电磁铁支架	1
39	G06-6-37	RUBBER RING	橡胶垫	1
40	G06-6-38	NUT	螺母	1
41	G06-6-39	SOLENOID LEVER ASSY	切线电磁铁顶销	1
42	G06-6-40	SCREW 15/64"x28	螺钉	1
43	G06-6-41	SHOULDER SCREW,SM15/64"x28	轴位螺钉	1
44	G06-6-42	TUBE HOLDER LOWER	旋梭供油管压板	1
45	G06-6-43	SPRING	弹簧	1
46	G06-6-44	TENSION RELEASE LEVER	松线座	1
47	G06-6-45	WASHER,PLALN SPECLAL8	垫片8	1
48	G06-6-46	NYLON CONNECTOR,14P	尼龙接头14P	1
49	G06-6-47	CONNECTOR CAP	插头套	1
50	G06-6-48	BAND	扎带	1

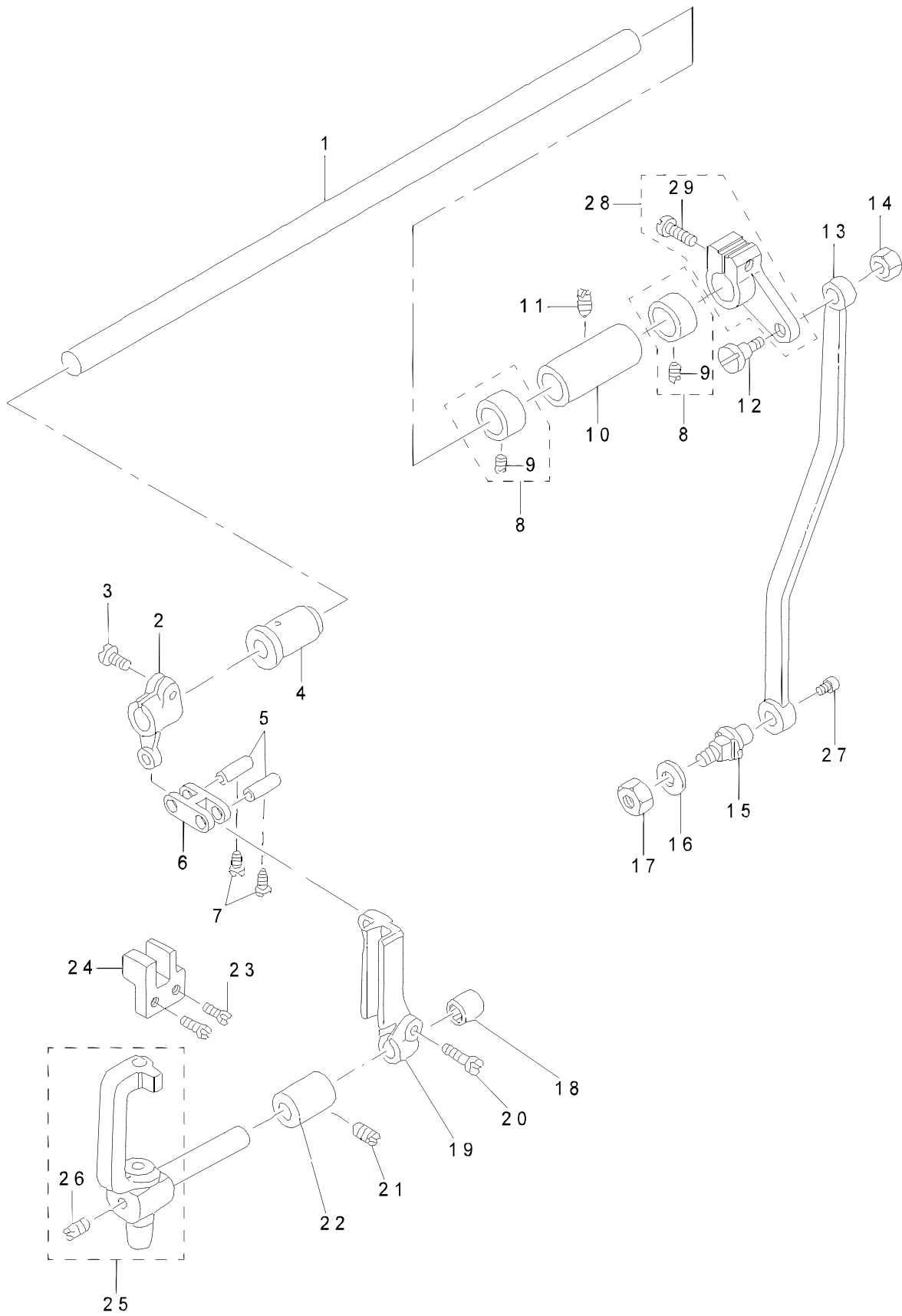

## 7 摆针分组件 NEEDLE BAR FRAME COMPONENTS

序号 NO	件号 Parts NO.	DESCRIPTION	名称	数量 Qty
1	G06-7-1	CONNECTING SHAFT	摆动轴	1
2	G06-7-2	DRIVING CRANK FRONT	前驱动曲柄	1
3	G06-7-3	SCREW 3/16-28 L=11.5	牙架座螺钉	1
4	G06-7-4	ROCKER SHAFT BUSHING FRONT	轴前套	1
5	G06-7-5	NEEDLE BAR LINK PIN	连接销	2
6	G06-7-6	DRIVING LINK	驱动连杆	1
7	G06-7-7	SCREW 9/64-40 L=8	螺钉	2
8	G06-7-8	THRUST COLLAR ASM.	挡圈组件	2
9	G06-7-9	SCREW 1/4-40 L=4.2	挡圈螺钉	(4)
10	G06-7-10	ROCKER SHAFT BUSHING REAR	轴套	1
11	G06-7-11	SCREW 3/16-28 L=7	螺钉	1
12	G06-7-12	HINGE SCREW D=7.94 H=5	轴位螺钉	1
13	G06-7-13	CONNECTING ROD	针送连杆	1
14	G06-7-14	NUT 15/64-28	螺母	1
15	G06-7-15	CONNECTING ROD SHAFT	调节螺钉	1
16	G06-7-16	WASHER 6.2*13*1	垫圈	1
17	G06-7-17	NUT 15/64-28	螺母	1
18	G06-7-18	BEARING	滚针轴承	1
19	G06-7-19	SLIDE BLOCK GUIDE	滑块导轨	1
20	G06-7-20	SCREW 3/16-28 L=15.5	内六角圆柱头螺钉	1
21	G06-7-21	SCREW 3/16-28 L=7	螺钉	1
22	G06-7-22	BEARING	针杆支架轴套	1
23	G06-7-23	SCREW 9/64-40 L=7.5	活压脚螺钉	2
24	G06-7-24	NEEDLE BAR FRAME GUIDE	针杆支架导轨	1
25	G06-7-25	NEEDLE BAR GUIDE BRACKET ASM.	针杆支架组件	1
26	G06-7-26	SCREW 11/64-40 L=2.8	针杆支架螺钉	(1)
27	G06-7-27	SCREW 11/64-40 L=6	轴位螺钉	1
28	G06-7-28	SHAFT ARM ASM.(REAR)	后驱动曲柄组件	1
29	G06-7-29	SCREW 3/16-28 L=14	后驱动曲柄螺钉	(1)



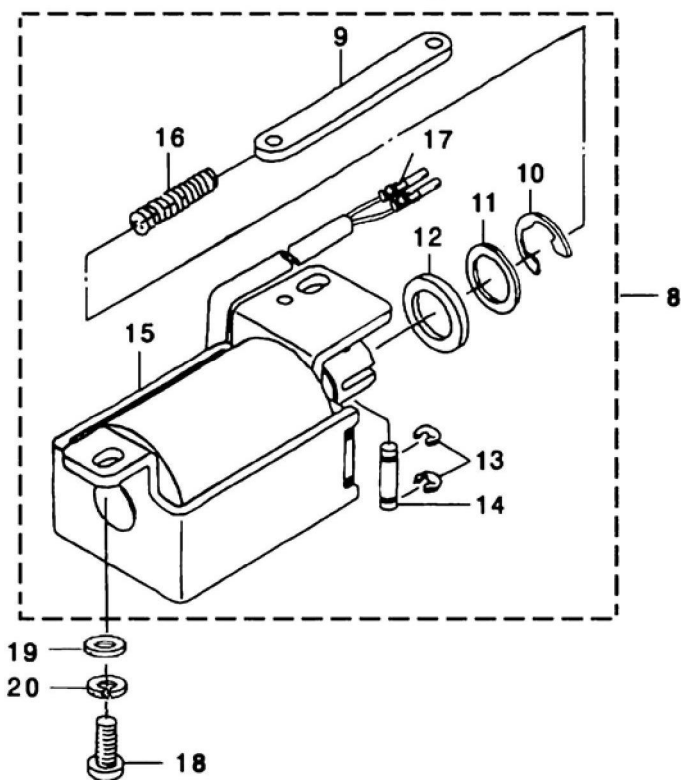
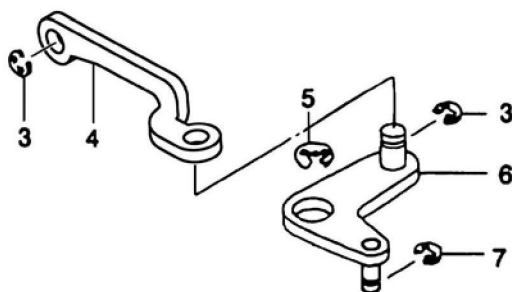
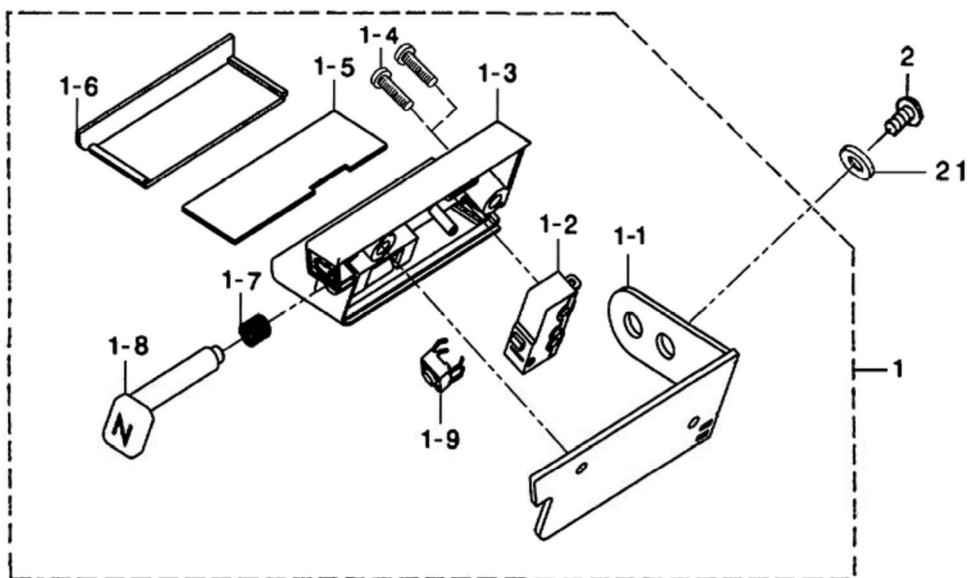

## 8.自动倒缝分组件 AUTOMATIC REVERSE FEED MECHANISM COMPONENTS

序号 NO	件号 Parts NO.	DESCRIPTION	名称	数量 Qty
1	G06-8-1	REVERSE SWITCH ASM.	自动倒缝开关组件	1
2	G06-8-1-1	REVERSE SWITCH BRACKET	开关支架板	(1)
3	G06-8-1-2	JIGGLE SWITCH	微动开关	(1)
4	G06-8-1-3	SWITCH BOX	开关盒	(1)
5	G06-8-1-4	SCREW	螺钉	(2)
6	G06-8-1-5	CIRCUIT PLATE	电路板	(1)
7	G06-8-1-6	PC PLATE	PC板	(1)
8	G06-8-1-7	SPRING	压簧	(1)
9	G06-8-1-8	JIGGLE KEY-PRESS	微动按钮	(1)
10	G06-8-1-9	SWITCH	按动开关	(1)
11	G06-8-2	SCREW	螺钉SM3/16x28 L=6	1
12	G06-8-3	E-RING 5	拉杆挡圈E5	1
13	G06-8-4	REVERSE FEED CONNECTING SHAFT	自动倒送料拉杆	1
14	G06-8-5	E-RING 9	油泵连接柱挡圈E9	1
15	G06-8-6	CONNECTING ARM ASM	倒缝曲柄	1
16	G06-8-7	E-RING 4	倒缝曲柄销挡圈E4	1
17	G06-8-8	REVERSE FEED ASM	自动倒缝组件	1
18	G06-8-9	REVERSE FEED CONNECTING LINK	倒缝铁芯连杆	1
19	G06-8-10	E-RING 12	倒缝铁芯挡圈E12	1
20	G06-8-11	WASHER 16X24X2.6	垫片	1
21	G06-8-12	RUBBER PLUNGER	橡胶垫片	1
22	G06-8-13	E-RING	连接销卡簧	2
23	G06-8-14	PLUNGER ARM PIN	倒缝铁芯连接销	1
24	G06-8-15	REVERSE FEED MAGNET ASM	倒缝电磁铁	1
25	G06-8-16	PLUNGER SPRING	连杆定位簧	1
26	G06-8-17	PIN CONTACT	导线插针	2
27	G06-8-18	SCREW 15/64-28 L=12	电磁铁紧固螺钉	2
28	G06-8-19	WASHER	螺钉平垫片	2
29	G06-8-20	SPRING WASHER	螺钉弹性垫片	2
30	G06-8-21	WASHER	螺钉平垫片	1

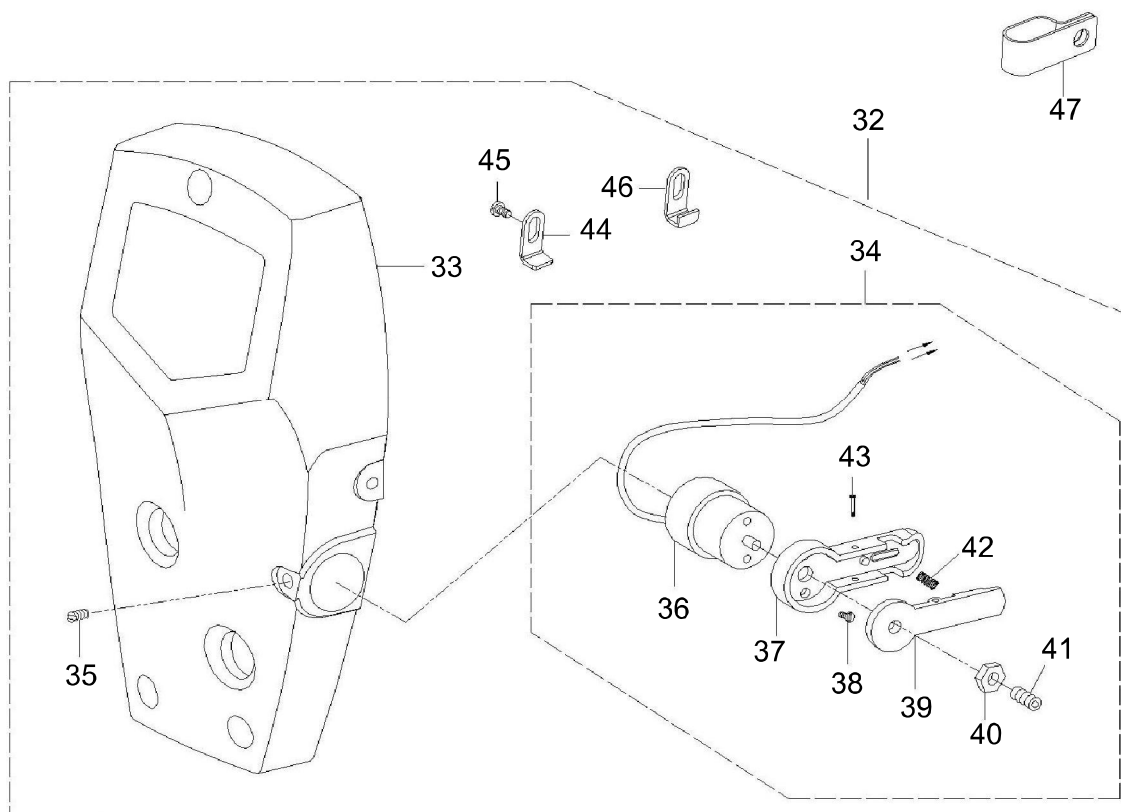
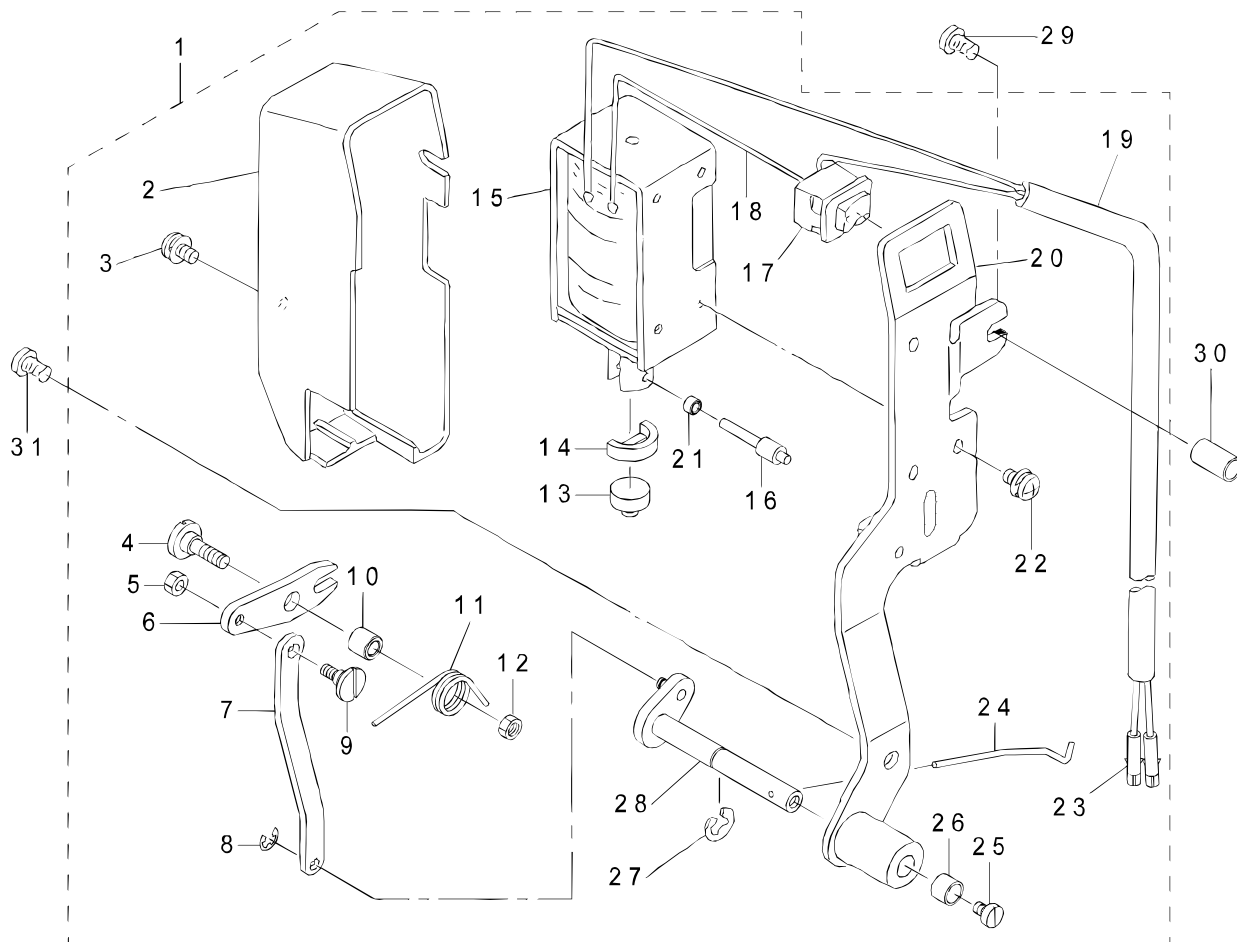

## 9.拨线分组件 WIPER COMPONENTS

序号 NO	件号 Parts NO.	DESCRIPTION	名称	数量 Qty
1	G06-9-1	WIPER ASM.	拨线部件	1
2	G06-9-2	WIPER COVER	拨线支架壳	(1)
3	G06-9-3	SCREW M3X6	拨线壳紧固螺钉	(1)
4	G06-9-4	HINGE SCREW D=6.5 H=3.2	传动板轴位螺钉	(1)
5	G06-9-5	NUT 9/64-40	螺母	(1)
6	G06-9-6	WIPER LINK A	拨线传动板	(1)
7	G06-9-7	WIPER LINK B	拨线拉杆	(1)
8	G06-9-8	E-RING 2.5	挡圈	(1)
9	G06-9-9	WIPER LINK B HINGE SCREW	挡杆轴位连接螺钉	(1)
10	G06-9-10	WIPER HINGE SCREW COLLAR	传动板滚柱	(1)
11	G06-9-11	WIPER SPRING	传动板复位簧	(1)
12	G06-9-12	NUT 11/64-40	传动板复位螺母	(1)
13	G06-9-13	WIPER RUBBER A	铁蕊定位垫	(1)
14	G06-9-14	WIPER RUBBER B	铁蕊月牙垫	(1)
15	G06-9-15	WIPER SOLENOID	拨线电磁铁组件	(1)
16	G06-9-16	WIPER SOLENOID SHAFT	传动销	(1)
17	G06-9-17	POWER SWITCH	开关	(1)
18	G06-9-18	ELECTRIC WIRE	导线	(0.04)
19	G06-9-19	2-CORE CABTYRE CORD	导线管	(1.33)
20	G06-9-20	WIPER BASE ASM.	拨线座组件	(1)
21	G06-9-21	WIPER LINK COLLAR	传动销螺母	(1)
22	G06-9-22	SCREW	电磁铁紧固螺钉	(3)
23	G06-9-23	PIN CONTACT	插针	(2)
24	G06-9-24	WIPER	拨线杆	(1)
25	G06-9-25	SCREW 9/64-40 L=5.0	拨线杆紧固螺钉	(1)
26	G06-9-26	WIPER COLLAR	拨线杆紧固套	(1)
27	G06-9-27	E-RING	拨线驱动轴挡圈	(1)
28	G06-9-28	WIPER DRIVING SHAFT ASM.	拨线驱动轴组件	(1)
29	G06-9-29	SCREW 3/16-28 L=18	拨线座紧固螺钉	1
30	G06-9-30	COLLAR	垫圈	1
31	G06-9-31	SCREW 3/16-28 L=9	螺钉	1
32	G06-9-32	THREAD TENSION ASM.FOR FACE PLATE	面板夹线器组件	1
33	G06-9-33	FACE PLATE	面板	1
34	G06-9-34	THREAD TENSION ASM.	电子夹线器组件	1
35	G06-9-35	SCREW 11/64-40 L=4	螺钉	1
36	G06-9-36	TENSION ELECTROMAGNET	电子夹线器套	1
37	G06-9-37	THREAD TENSION DISK PRESSER	夹线座	1
38	G06-9-38	SCREW	螺钉	2
39	G06-9-39	THREAD TENSION DISK PRESSER	夹线板	1
40	G06-9-40	NUT	螺母	1
41	G06-9-41	SCREW	螺钉	1
42	G06-9-42	SPRING	复位簧	1
43	G06-9-43	SCREW	螺钉	1
44	G06-9-44	CORD FIXING METAL FITTING L	L形线夹	1
45	G06-9-45	SCREW SM3/16-28 L=6	螺钉	1
46	G06-9-46	CORD FIXING METAL FITTING L	L形线夹	1
47	G06-9-47	CORD FIXING METAL FITTING U	U形线夹	1

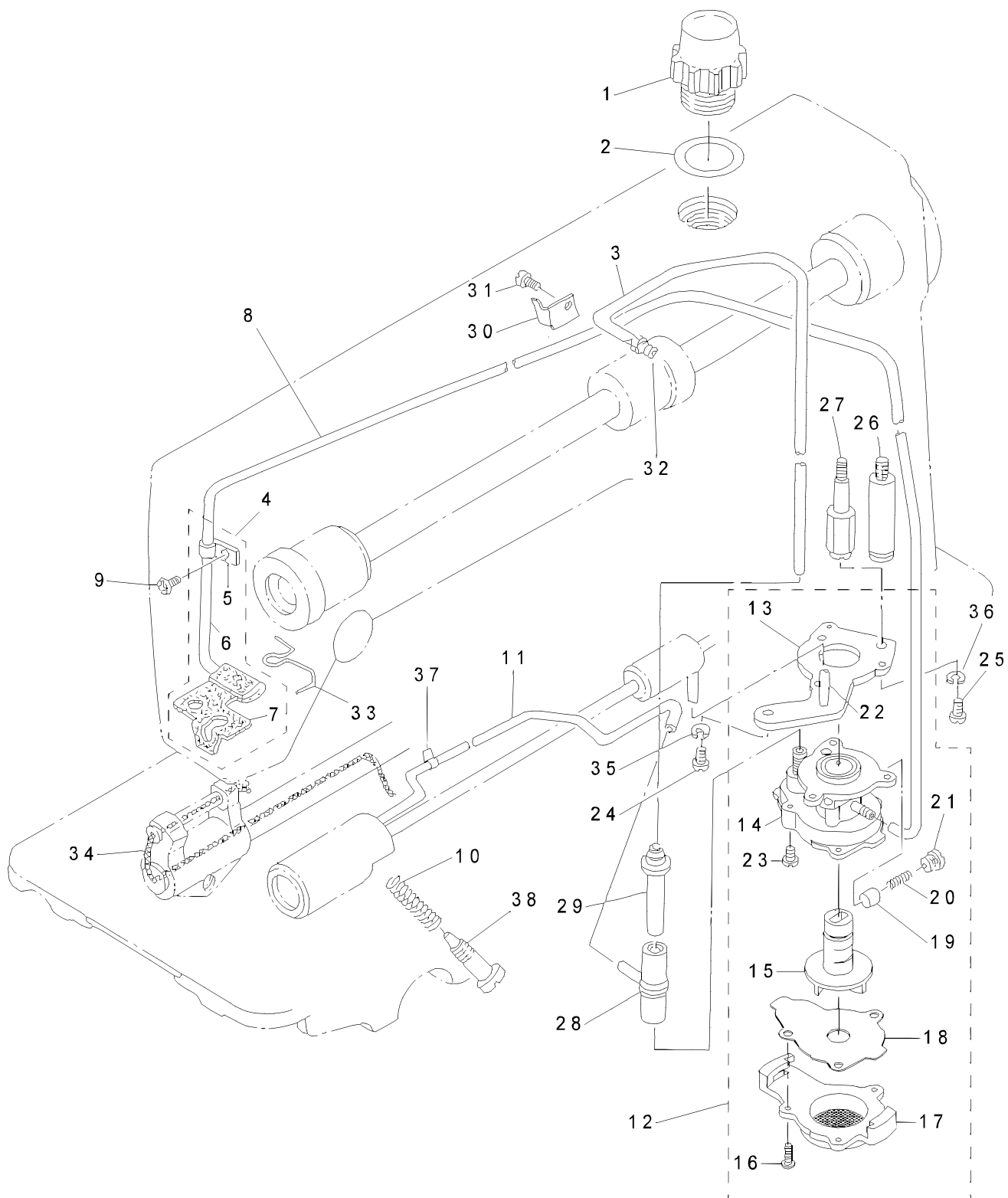

## 10. 润滑分组件 OIL LUBRICATION COMPONENTS

序号 NO	件号 Parts NO.	DESCRIPTION	名称	数量 Qty
1	G06-10-1	OIL SIGHT WINDOW	油窗	1
2	G06-10-2	RUBBER RING	油窗O型圈	1
3	G06-10-3	OIL TUBE	上轴供油管	1
4	G06-10-4	OIL RETURN TUBE ASM.	回油管夹组件	1
5	G06-10-5	HOLDER	回油管夹	(1)
6	G06-10-6	FELT B	回油管	(1)
7	G06-10-7	FELT A	羊毛毡	(1)
8	G06-10-8	OIL TUBE	供油管	1
9	G06-10-9	SCREW 3/16-28 L=6	回油管夹螺钉	1
10	G06-10-10	OIL REGULATOR SCREW SPRING	旋梭油量调节簧	1
11	G06-10-11	OIL WICK ASM.	旋梭供油管	1
12	G06-10-12	OIL PUMP ASM.	油泵部件	1
13	G06-10-13	OIL PUMP INSTALLING BASE	油泵安装板	(1)
14	G06-10-14	OIL PUMP	油泵体	(1)
15	G06-10-15	IMPELLER	油泵叶轮	(3)
16	G06-10-16	SCREW D=3 L=10	油泵盖螺钉	(1)
17	G06-10-17	PUMP BODY COVER	油泵盖	(1)
18	G06-10-18	PUMP BODY SUPPORT PLATE	油泵叶轮托板	(1)
19	G06-10-19	PLUNGER	回油柱塞	(1)
20	G06-10-20	PLUNGER SPRING	柱塞簧	(1)
21	G06-10-21	PLUNGER SCREW	柱塞螺钉	(1)
22	G06-10-22	HOOK DRIVING SHAFT OILING PIPE	下轴供油管	(1)
23	G06-10-23	SCREW M3 L=8	油泵安装螺钉	(3)
24	G06-10-24	SCREW 15/64-28 L=9	螺柱连接螺钉	1
25	G06-10-25	SCREW 15/64-40 L=9.5	螺柱连接螺钉	1
26	G06-10-26	PUMP BODY STRUT	油泵连接螺柱	1
27	G06-10-27	OIL PUMP SUPPORT	油泵连接螺柱	1
28	G06-10-28	RUBBER JOINT	供油管接头	1
29	G06-10-29	OIL TUBE JOINT	供油管下接头	1
30	G06-10-30	HOLDER	管夹	1
31	G06-10-31	SCREW 1/8-44 L=2.9	管夹螺钉	1
32	G06-10-32	CONNECTING SCREW	供油管上接头	1
33	G06-10-33	OIL FELT PRESSER	回油毡夹	1
34	G06-10-34	OIL WICK	送料轴油线	1
35	G06-10-35	SPRING WASHER 4.5*8.5*1	螺柱连接螺钉垫圈	1
36	G06-10-36	SPRING WASHER 6.5*11*1.3	螺柱连接螺钉垫圈	1
37	G06-10-37	CABLE BAND 150	扎带	1
38	G06-10-38	OIL REGULATOR SCREW	旋梭油量调节螺钉	1

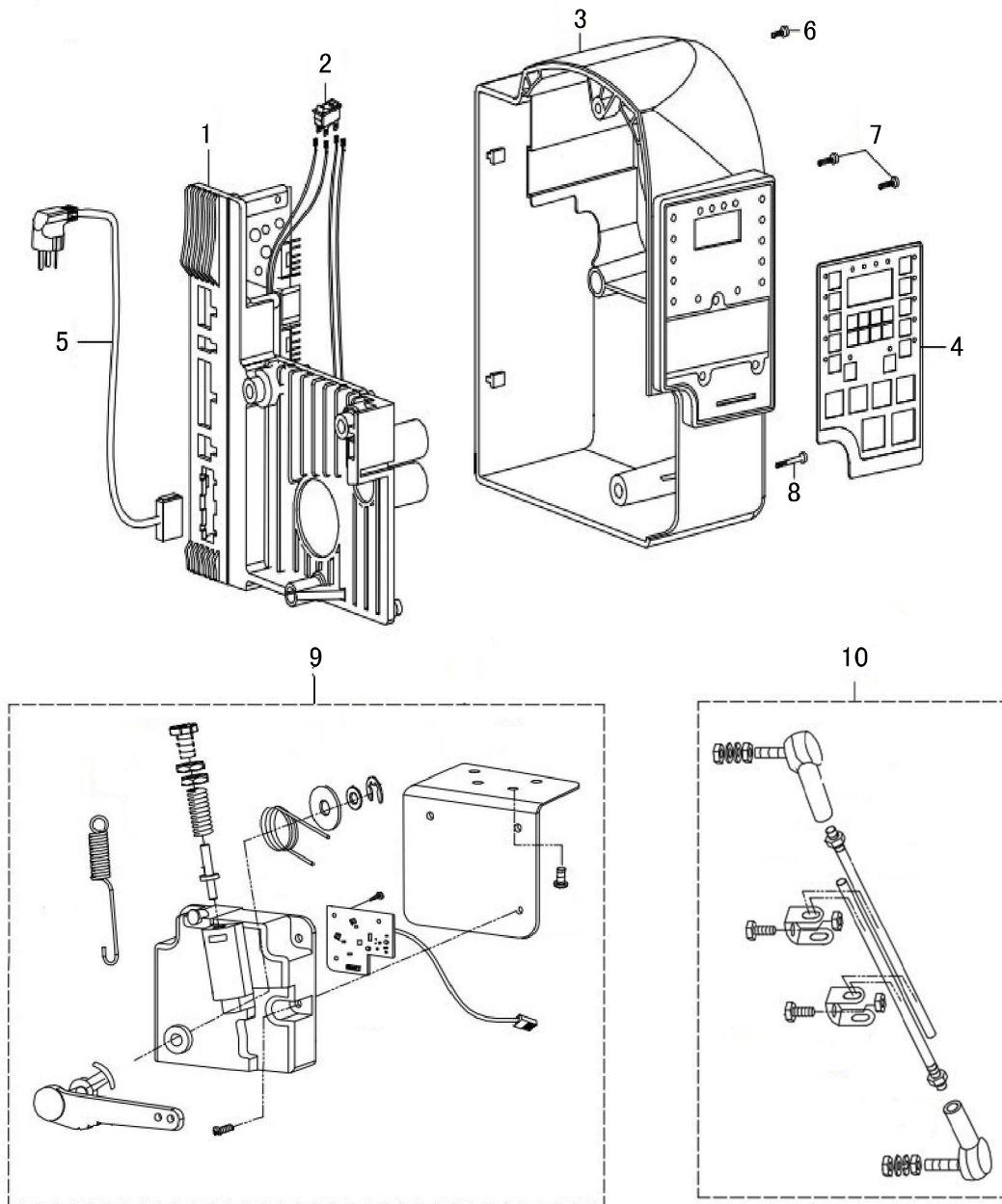

## 11. 电控 DRIVER COMPONENTS

序号 NO	件号 Parts NO.	DESCRIPTION	名称	数量 Qty
1	G06-11-1	CONTROL ASM	电控组件	1
2	G06-11-2	POWER SWITCH	电源开关	1
3	G06-11-3	CONTROL COVER	电控罩	1
4	G06-11-4	CONTROL PANEL ASM.	操纵面板贴	1
5	G06-11-5	POWER LINE	电源线	(1)
6	G06-11-6	SCREW M5	螺钉	(1)
7	G06-11-7	SCREW M5	螺钉	2
8	G06-11-8	SCREW M5	螺钉	1
9	G06-11-9	THREADLE ASM	脚踏控速器	1
10	G06-11-10	LIVE FESTIVAL BALL LINK ASM.	拉杆	1



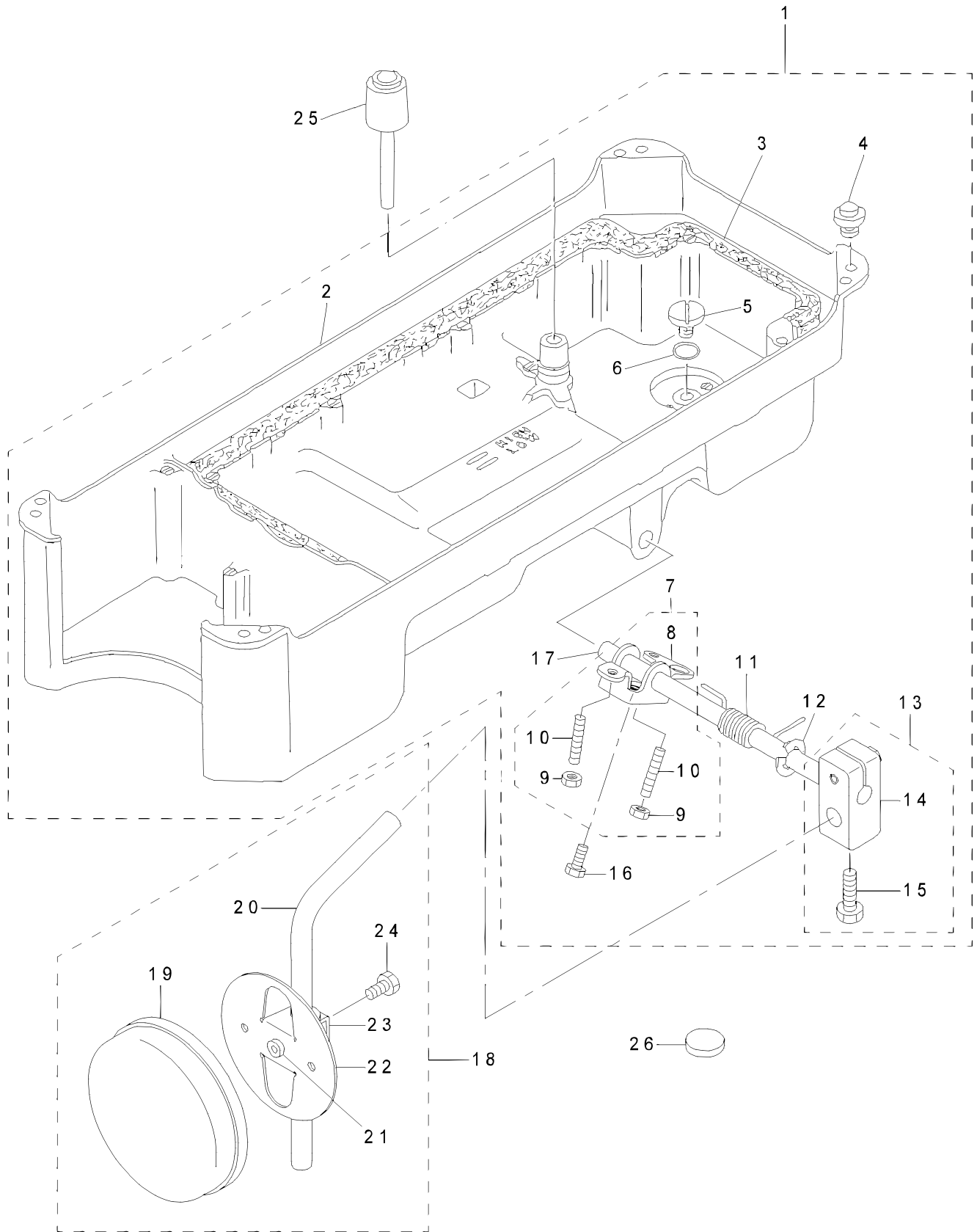

## 12.油盘分组件 OIL RESERVOIR COMPONENTS

序号 NO	件号 Parts NO.	DESCRIPTION	名称	数量 Qty
1	G06-12-1	OIL RESERVOIR ASM.	油盘部件	1
2	G06-12-2	OIL RESERVOIR	油盘	(1)
3	G06-12-3	GASKET	油盘垫	(1)
4	G06-12-4	RUBBER CUSHION	机头坐垫	(4)
5	G06-12-5	SCREW 5/16-24 L=7	排油孔螺钉	(1)
6	G06-12-6	RUBBER RING	排油孔螺钉O型圈	(1)
7	G06-12-7	KNEE LIFTER ROTATION ARM ASM.	抬压脚双向曲柄部件	(1)
8	G06-12-8	KNEE LIFTER ROTATION ARM	抬压脚双向曲柄	(1)
9	G06-12-9	NUT M6	双向曲柄限位调节螺母	(2)
10	G06-12-10	SCREW M6 L=30	双向曲柄限位调节螺钉	(2)
11	G06-12-11	SPRING	双向曲柄弹簧	(1)
12	G06-12-12	E-RING 10	抬压脚轴开口挡圈	(1)
13	G06-12-13	BRACKET ASM.	抬压轴操纵杆节头部件	(1)
14	G06-12-14	BRACKET	抬压轴操纵杆节头	(1)
15	G06-12-15	BRACKET SCREW	操纵杆节头螺钉	(2)
16	G06-12-16	SCREW M6 L=17.5	双向曲柄螺钉	(1)
17	G06-12-17	KNEE PRESS CROSS SHAFT	抬压脚轴	(1)
18	G06-12-18	KNEE PAD PLATE ASM.	操纵杆部件	1
19	G06-12-19	KNEE PAD PLATE COVER	操纵板软垫	(1)
20	G06-12-20	KNEE PAD UPRIGHT SHAFT	操纵杆	(1)
21	G06-12-21	KNEE PAD PLATE RUBBER	操纵杆垫	(1)
22	G06-12-22	KNEE PAD PLATE	操纵板	(1)
23	G06-12-23	KNEE PAD PLATE SUPPORT	操纵杆节头	(1)
24	G06-12-24	SCREW M6 L=12	节头螺钉	(1)
25	G06-12-25	KNEE LIFTER PUSH ROD	抬压脚顶销	1
26	G06-12-26	OIL REGULATOR MAGNET	油盘磁铁	1

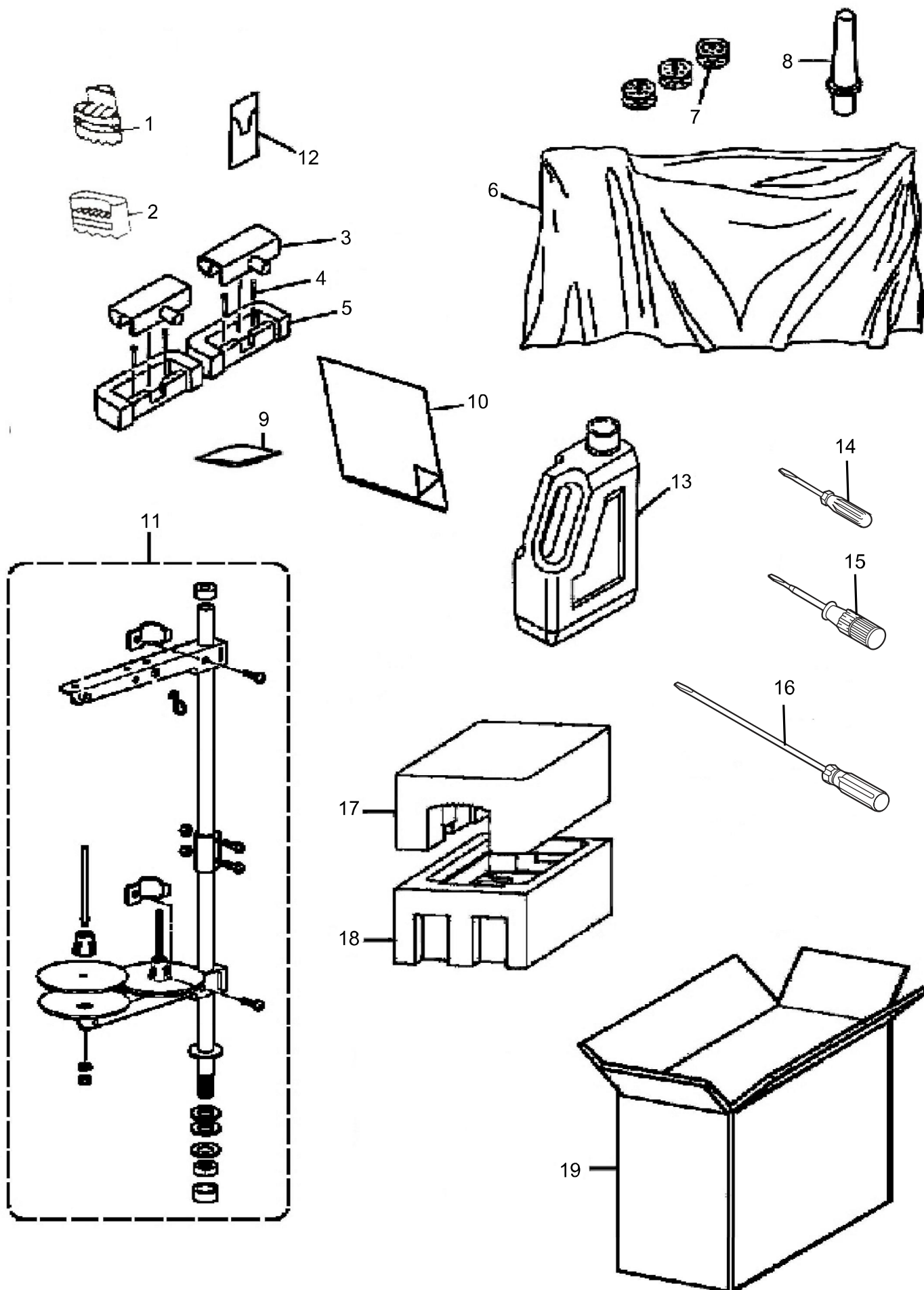

### 13.附件 THREAD STAND COMPONENTS

序号 NO	件号 Parts NO.	DESCRIPTION	名称	数量 Qty
1	G06-13-1	QUAKEPROOF WASHER B	防震垫B	2
2	G06-13-2	QUAKEPROOF WASHER A	防震垫A	2
3	G06-13-3	MACHINE HINGE PLATE ASM.	机头连接钩	2
4	G06-13-4	MACHINE HINGE PLATE	机头连接钩座钉	4
5	G06-13-5	NAIL	机头连接钩座	2
6	G06-13-6	MACGUBE HEAD COVER	机头罩	1
7	G06-13-7	BOBBIN	梭芯	3
8	G06-13-8	MACGUBE REST COVER	机头支柱	1
9	G06-13-9	AIR DRIER	干燥剂	1
10	G06-13-10	INSTRUCTION BOOK	说明书	1
11	G06-13-11	THREAD STAND ASM.	过线架部件	1
12	G06-13-12	NEEDLE DBx1 #14	机针包	1
13	G06-13-13	OIL RESERVOIR ASM	油壶	1
14	G06-13-14	SCREW DRIVER,SMALL	小螺丝刀	1
15	G06-13-15	SCREW DRIVER,MIDDLE	中螺丝刀	1
16	G06-13-16	SCREW DRIVER,LARGE	大螺丝刀	1
17	G06-13-17	FOAM MAT (TOP)	泡沫垫（上）	1
18	G06-13-18	FOAM MAT (BOTTOM)	泡沫垫（下）	1
19	G06-13-19	OUTSIDE BOX	纸箱	1

14. 自动抬压脚电磁铁（选购）

**PRESSER FOOT LIFTING SET MECHANISM (OPTION PARTS)**

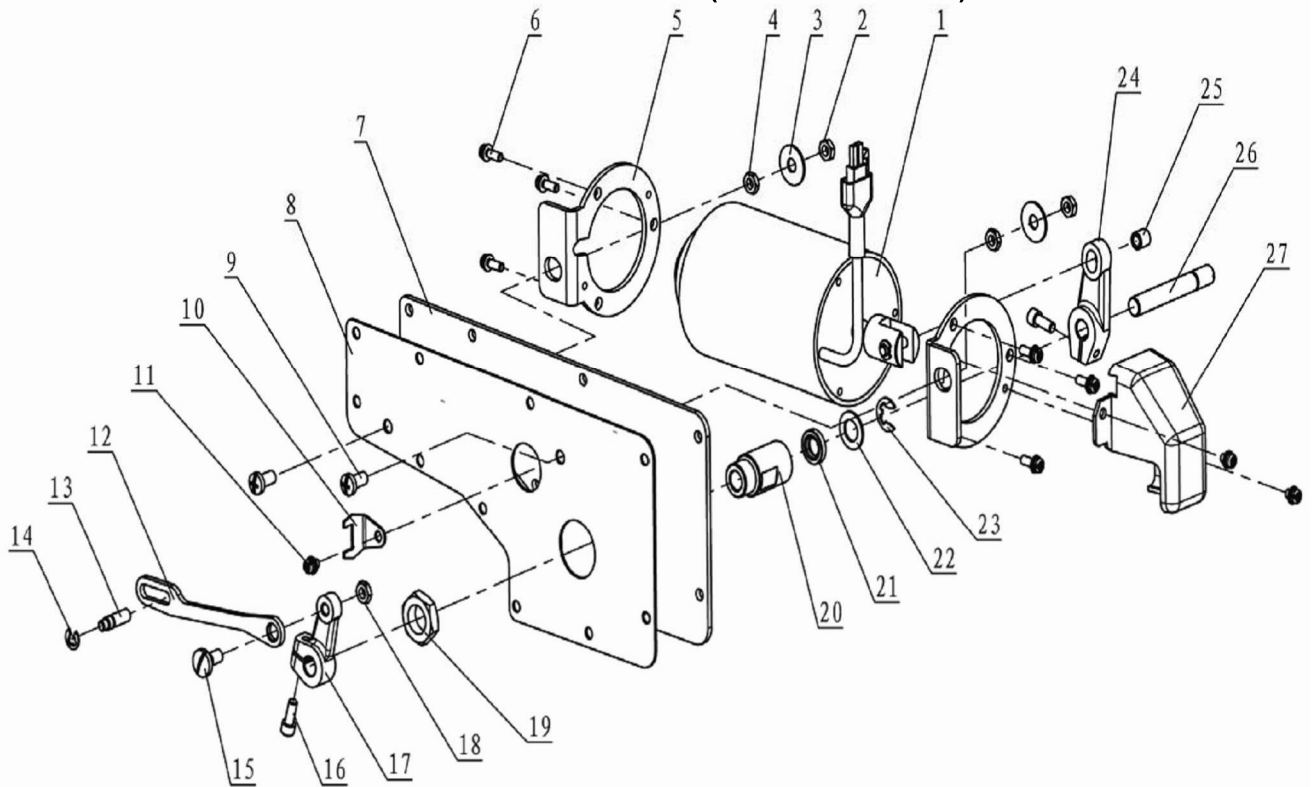

14. 自动抬压脚电磁铁（选购）

**PRESSER FOOT LIFTING SET MECHANISM (OPTION PARTS)**

序号 NO	件号 Part.NO	Name of parts	名 称	数量 Qty
1	G06-14-1	Electromagnet ASM	电磁铁组件	1
2	G06-14-2	Screw cover of electromagnet s	螺帽 SM15/64x28x4	2
3	G06-14-3	Electromagnet holder ring	垫圈 .3x1.5x 9	2
4	G06-14-4	Nut	螺帽 SM15/64x28x2.8	2
5	G06-14-5	Electromagnet stand	电磁铁支架	2
6	G06-14-6	Screw of electromagnet stand	电磁铁支架螺丝Mx11	6
7	G06-14-7	Side plate	后窗板	1
8	G06-14-8	Gasket	后窗板垫	1
9	G06-14-9	Screw	螺丝 SM15/64x28x12	2
10	G06-14-10	Snap cover	限位板	1
11	G06-14-11	Screw	螺丝 M4x6	3
12	G06-14-12	Connecting rod	连杆	1
13	G06-14-13	Limit screw	限位螺杆	1
14	G06-14-14	Snap ring of limit screw	卡环 5x0.8x 10	1
15	G06-14-15	Screw of connecting	连杆螺丝	1
16	G06-14-16	Screw of crank	螺丝 SM3/16X28X12	2
17	G06-14-17	Presser foot pin	抬压脚曲柄	1
18	G06-14-18	Nut of connecting	螺帽 SM15/64x28x3	1
19	G06-14-19	Nut of bushing	螺帽 SM16x1.5x5	1
20	G06-14-20	Bushing	轴套	1
21	G06-14-21	Oil seal	油封 8.2x3.5x 16	1
22	G06-14-22	Bushing ring	垫圈 0.5x0.9x 8	1
23	G06-14-23	Snap ring	卡环 8x1x 16	1
24	G06-14-24	Electromagnet crank	电磁铁曲柄	1
25	G06-14-25	Crank cover of electromagnet c	电磁铁曲柄套	1
26	G06-14-26	Transmission shaft	传动轴	1
27	G06-14-27	Electromagnet shield	电磁铁罩	1
28	G06-14-28	Screw	螺钉	2

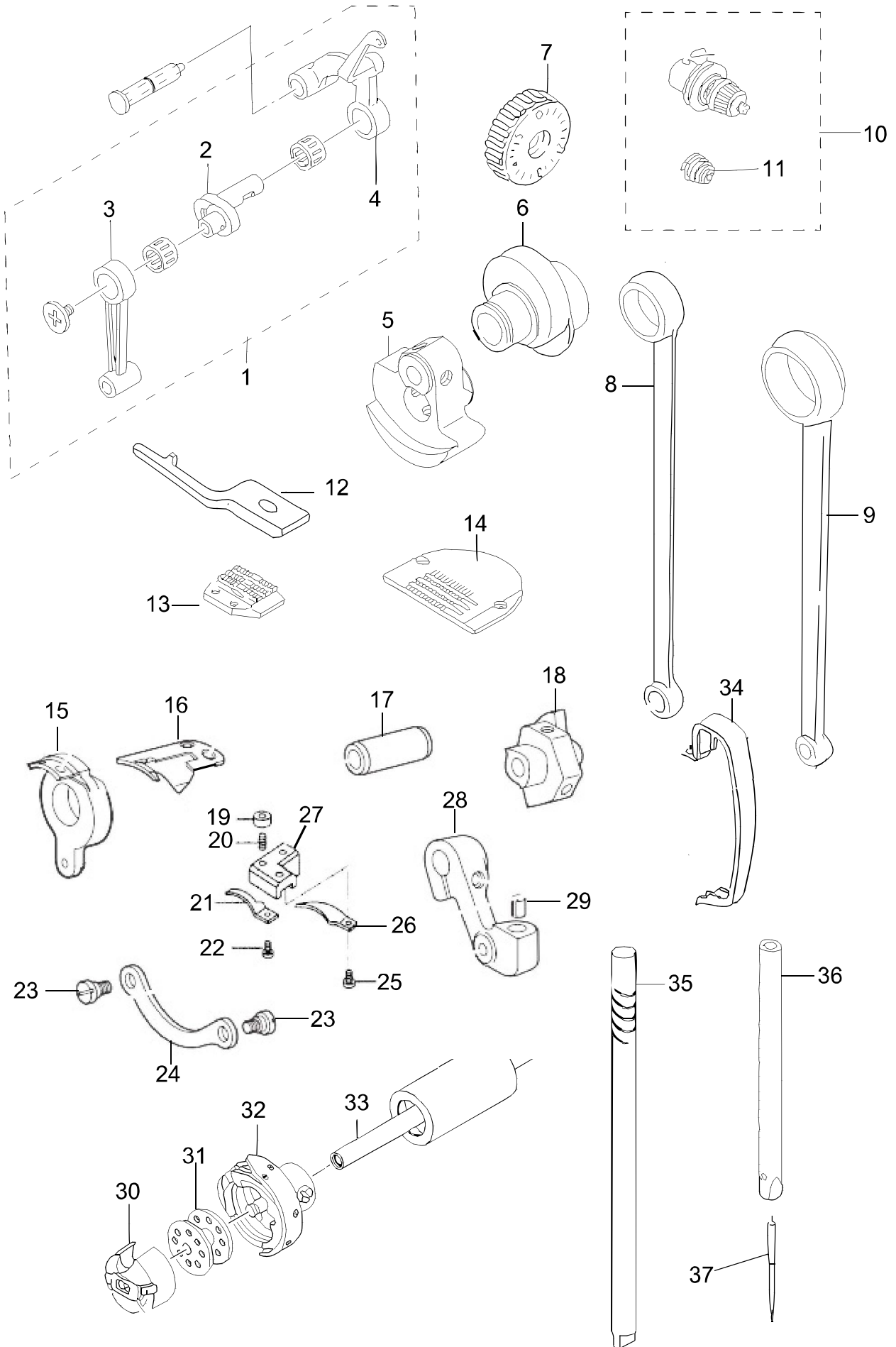

### 15.Exclusive parts for 3901LH-AUT

序号 NO	件号 Part.NO	Name of parts	名 称	数量 Qty
1	G08-15-1	Thread take-up lever ASM	挑线杆组件	1
2	G08-15-2	Needle bar crank	挑线曲柄部件	1
3	G08-15-3	Needle bar crank rod	针杆连杆	1
4	G08-15-4	Thread take-up lever	挑线连杆	1
5	G08-15-5	Counter weight	针杆曲柄	1
6	G08-15-6	Feed drive eccentric cam	送料偏心轮	1
7	G08-15-7	Feed dial	针距标盘	1
8	G08-15-8	Conneeting rod	抬牙连杆	1
9	G08-15-9	Rocker shaft conneeting rod	送布连杆	1
10	G08-15-10	Thread tension ASM.	夹线器组件	1
11	G08-15-11	Tension Disc stopper	夹线簧	1
12	G08-15-12	Positioning finger	定位勾	1
13	G08-15-13	Feed dog	送布牙	1
14	G08-15-14	Needle plate	针板	1
15	G08-15-15	Knife bracket	切线刀架	1
16	G08-15-16	Motorial knife	活动刀	1
17	G08-15-17	Thread shear cam bushing	切线轴套	1
18	G08-15-18	Thread shear cam	切线凸轮	1
19	G08-15-19	Nut	定刀座螺母	1
20	G08-15-20	Screw	定刀座螺钉	1
21	G08-15-21	Fixed knife	定刀	1
22	G08-15-22	Screw	定刀螺钉	1
23	G08-15-23	Screw	连杆螺钉	2
24	G08-15-24	Knife shaft connecting rad	刀架连杆	1
25	G08-15-25	Screw	分线板螺钉	1
26	G08-15-26	Lower thread finger	分线板	1
27	G08-15-27	Holder,F-knife	定刀座	1
28	G08-15-28	Thread shear rock crank	切刀驱动曲柄	1
29	G08-15-29	Positioning block	驱动曲柄止动块	1
30	G08-15-30	Bobbin case	梭壳	1
31	G08-15-31	Bobbin	锁芯	1
32	G08-15-32	Hook assy.	旋梭	1
33	G08-15-33	Lower shaft	下轴	1
34	G08-15-34	Cover	挑线杆防护罩	1
35	G08-15-35	Upringht shaft	竖轴	1
36	G08-15-36	Needle bar	针杆	1
37	G08-15-37	Neede #18-#21	机针#18-#21	1
				1
				1
				1



# GLOBAL

---

---