

GLOBAL

Our experience. Your success

ZZ-2565/2567/2568 AUT SERIES

INSTRUCTION MANUAL & PARTS LIST

ZZ-2565/2567/2568 AUT SERIES

INSTRUCTION MANUAL

CONTENT

1	Safety operating guide.....	2
2	Operating notice.....	2
3	Operating condition.....	2
4	Chief specification.....	2
5	Install belt.....	3
6	Install belt cover.....	3
7	The needle bar position adjustment.....	4
8	Operation guide.....	4
9	To lubricate the machine.....	4
10	The hook lubricating condition adjustment.....	4
11	Time machine cleaning.....	5
12	Wind the bobbin.....	5
13	Install the needle.....	6
14	Bobbin fixing and hook threading.....	6
15	To thread upper thread.....	7
16	The thread tension adjustment.....	7
17	The thread take up spring tension adjustment.....	8
18	The presser foot pressure adjustment.....	8
19	Stitch length setting mechanism.....	8
20	Zig-zag stitch width (throw) and position setting.....	9
21	Tooth clearance setting of zigzag stitch gear.....	10
22	Straight stitch alignment.....	10
23	Zigzag stitch width.....	11
24	Needle stab position setting in feeding direction.....	11
25	Lateral setting of needle stab position.....	12
26	Lateral setting of central straight stitch position.....	12
27	Lateral setting of straight stitches on throat plate needle hole edges, arresting of zigzag stitch setting mechanism.....	13
28	The gap between hook assembly and needle adjustment.....	13
29	Bobbin case driver.....	14
30	The feed dog height adjustment.....	14
31	The feed dog obliquity adjustment.....	14
32	Timing between needle and feed dog motion.....	15
33	The forward/backward stitch length error adjustment.....	15
34	The position between hook and opener motion adjustment.....	15
35	Form stitch of patterns cam series.....	16
	Tooth clearance setting of form stitch gear.....	16
	Roller bolt position of form stitch steering cam.....	16
	Setting of needle stab position.....	17
	Timing of form stitch steering cam to needle motion.....	17

36	Form stitch of patterns cam with part number.....	17
37	Backtacking with solenoid.....	18
38	Presser foot lifting.....	19
39	Bobbin winder.....	20
40	Thread trimming.....	20
41	Machine electronic control and drive.....	21

Thank you to choose zigzag stitch series industrial sewing machine

This is an instruction manual & parts list, it could help you how to use machine & how to care of machine correctly and make you convenience to look up parts.

In order to avoid trouble occurring, please read this instruction manual carefully before operating machine, and please accept safety operating guides with come from special technicians or peoples of having operator experiences.

1 Safety operating guide

- When turning the power on, keep your hands and fingers away from the area under the needle and around the pulley.
- Power must be turned off when the machine is not used or when the operator leaves his/her seat.
- Power must be turned off when incline the machine head, install/remove the belt or move machine.
- Do not place finger, hair, shaft etc. near pulley, belt, wheel and motor in order to avoid injury when the machine is in operation.
- Do not insert finger into the thread take up lever guard cover, keep your hands and fingers away from the area under the needle and around the pulley when the machine is in operation.
- Do not operate the machine without the safety devices if the belt cover or eye guard are installed.

2 Operating notice

- Do not operate the machine if the oil tank without full oil.
- The machine adopt semi-automatic lubricating mode. Do not operate the machine before lubricating.
- Check the rotation direction of pulley when firstly start new machine.(The pulley should rotate in counterclockwise when viewed from pulley)
- Check the voltage and phase.(Single or three phase whether is corresponding with the data in motor nameplate)

3 Operating condition

- Avoid using machine at abnormally high temperature (40°C or higher) or low temperature (5°C or lower). Otherwise machine failure may result.
- Avoid using machine in dusty condition.

4 Main technical specifications

	Large hook	Standard hook	Small hook
Max. zigzag stitch width/mm	10	8	6
Max. sewing speed for 6mm stitch width	Adjust as per the actual situation	Adjust as per the actual situation	3500
Max. sewing speed for 8mm stitch width	Adjust as per the actual situation	3000	—
Max. sewing speed for 10mm stitch width	2000	—	—
Standard sewing speed	2000	2500	2500

✘ **The machine is set up to the standard sewing speed in the factory.**

✘ The sewing speed value determined by the size of the hook must not be exceed with a respect to the machine's lifetime. Usually is necessary to do reduction the speed's value according to used thread, needle and sewn material.

Stitch type	double thread zig-zag lockstitch
Stitch length	max.5mm
Foot lifting with hand lever	5mm
Foot lifting with knee lever or solenoid	12mm
Lubricating mode	Semi-automatic lubricating
Needle system	134; 134-35
Manually controlled subclass	DC motor-positioning motor without further functions
Solenoid-controlled subclass	DC motor (AC servo) - positioning motor with reverse run after thread trimming
Sewing head weight	40kg
Sewing head (all-in-one machine) weight	
Stand weight	30kg
Thread length after trimming	max.20mm
Machine head clear workspace	265 x 120mm
Machine table dimensions	178 x 476mm
Input of machine with DC motor	max.800W (short-time at start up)
Machine floor plan dimensions (including stand)	1060 x 550mm

5 Install belt

- Use V-belt which special for sewing machine.
- To adjust the tension of belt. Change the height of motor through turn the tension adjusting nut. It is ok if the belt sinks inside with 15mm when pressing the center position of belt surface. Lacking tension will cause unstable running speed of machine, or needle stand at wrong stop position when machine in middle / slow running condition. Excessive tension will cause the motor bearing be damaged.

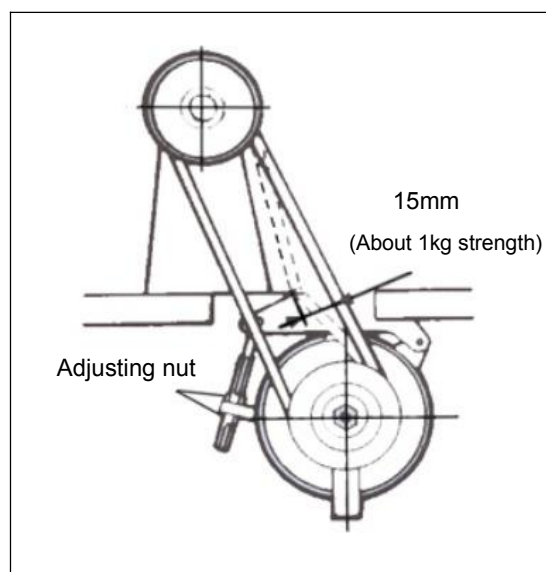

6 Install belt cover

Machine head and motor must install belt cover for safety.

7 The needle bar stop position adjustment

If the localizer adopts external hanging type, please refer to the motor instruction book for the adjustment method

→ “Up” Position

When the pedal is kicked down by heel, the machine should stop at “Up” position, i.e. the highest position of take-up lever.

→ “Down” Position

When the pedal is stand at middle position, the machine should stop at “Down” position, i.e. the needle bar raises 3mm from its lowest position.

8 Operation guide (motor and control box)

- Keep foot away from pedal when turn on / off the power. Power must be turned off when the operator leaves his / her seat.
- The detent can't work when the power is interrupted or power failure occurs during the machine operation.
- Keep the control box cover is closed during operation in order to avoid accidental operation since the dust come into control box.
- Must use multimeter to check control loop circuit in order to protect the semiconductor parts
- Power must be turned off when incline machine head only or touch needle.
- Must use earth cable (with yellow / green color) to connect motor.
- When check the internal circuit, it must turn off the power firstly and then open the front cover.
- It must wait 10 minutes after turn off the power due the high voltage in box. (It is very important to release the internal energy)
- Keep motor away from much noise area such as high frequency welding area when use it.

9 To lubricate the machine

Clean the machine completely before operate it daily, and check the oil quantity of hook oil tank. Then inject oil as arrow shows in below picture, start operation of machine.

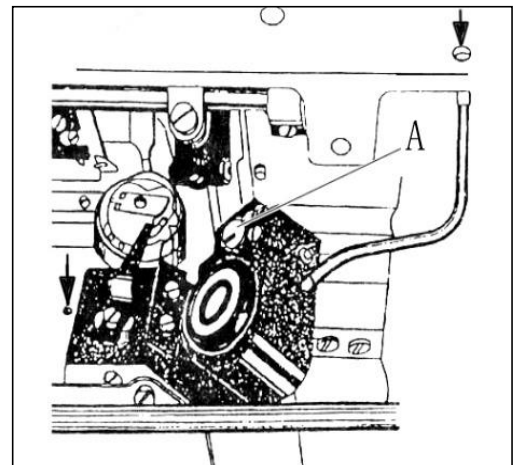
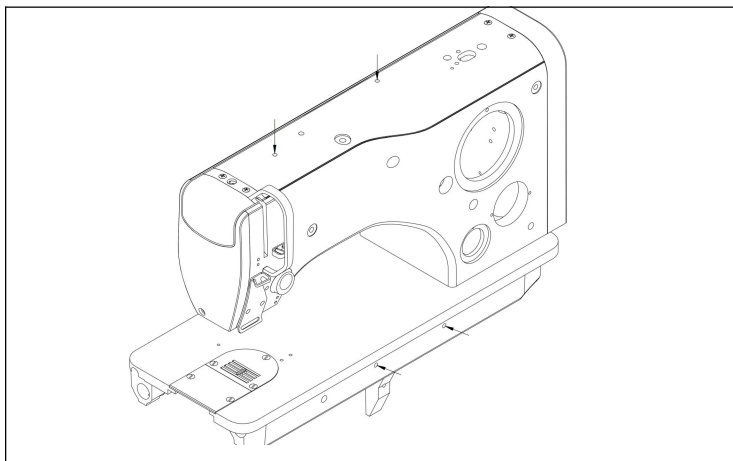

10 The hook lubricating condition adjustment (see above picture)

- To adjust hook lubricating through screw A which site before oil tank of hook.
- The oil quantity is lowest when screw A was turned with clockwise and the arrow points to “0” position.
- The oil quantity is highest when screw A was turned with anticlockwise and the arrow points to “MAX” position.

11 Time machine cleaning

The hook, feed dog and other parts of machine should be cleaned daily, and drop two or three coal oil into hook and other parts that need to be lubricated. Clean all the spilth after ending of highest speed operation of machine, then lubricate the machine with oil. The clean work must be insisted every day. (Especially the machine worked one week, the clean work is very important, as the spilth will affect the sewing capability and rust hook and machine. It should take away bobbin from hook before cleaning.)

Maintenance of motor: clean dust of the motor cover each one month or two months. (More dust or sundries of motor cover will make it too hot.)

Maintenance of control box: clean dust of the connector. (It will affect accidental operation if there is more dust on the connector.)

Warning!

Before cleaning and lubricating the machine, be sure to switch off all switches and hold your feet away from the machine stand pedal in order to avoid accidental machine start by pedal.

12 Wind the bobbin

- Fix the bobbin (1) on the winder.
- Do the threading according to picture (A), wind 5 times round the bobbin.
- Insert the thread under cutter (2) and tear off by pulling in the arrow direction (3).
- Pull the lever (4) in the arrow direction (5).
- Start the machine up.
- After the bobbin winding, wind the thread round the cutter (2) according to picture (B) and tear it off by pulling in the arrow direction (3).
- Fix another bobbin immediately and prepare its winding during the sewing.

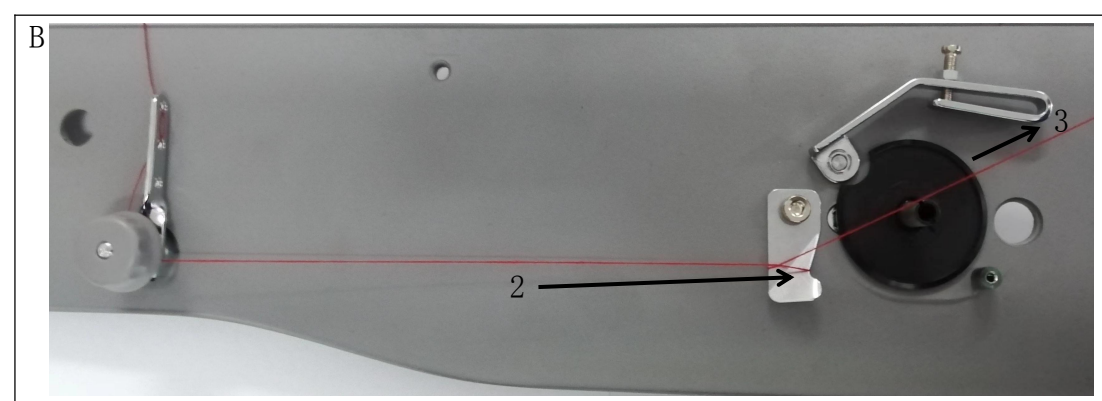
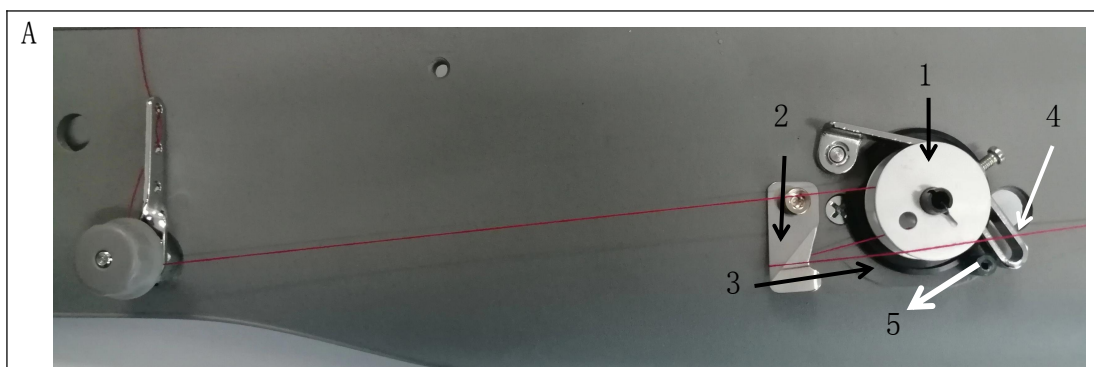

13 Insert the needle

Please use DPx17 NO. 90-120 needle, the thickness of needle should be decided according to the thickness of sewing material & thread. When insert the needle, rotate the hand wheel until the needle bar has reached its top position, loosen the screw on the lower part of the needle bar and insert the needle. Be sure that the long groove of the needle directly toward the operator and check whether the needle shank has reached the bottom of the needle hole. Fix the needle by tightening the screw.

Warning!

Before insert the needle, be sure to switch off the main switch.

If the terylene thread is broken when backstitch, turn the needle groove to right, maybe can avoid this condition. Normally avoid the needle groove face to left.

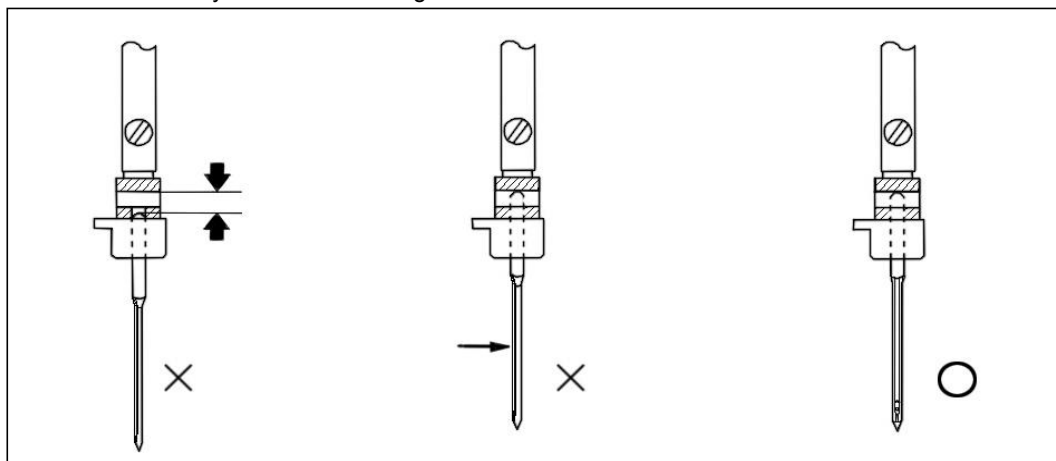

14 Bobbin fixing and hook threading

Attention! Danger of injury!

Switch the main switch off and wait for the motor stopping.

- Tilt the flap (1), grip it and pull the bobbin case (2) out of the hook.
- Put the bobbin (3) in the bobbin case with the thread end (4) oriented according to the picture.
- Draw the thread end (4) through the slit (5), pull under the spring (6) and pull into the slit (7).
- Insert the case (2) back in the hook and press it down in the arrow direction (8) till the lock inside the case clicks and secures it against falling out.
- Make one stitch without the sewn material, and drawing the thread upper end, pull the hook thread end outwards above the throat plate.

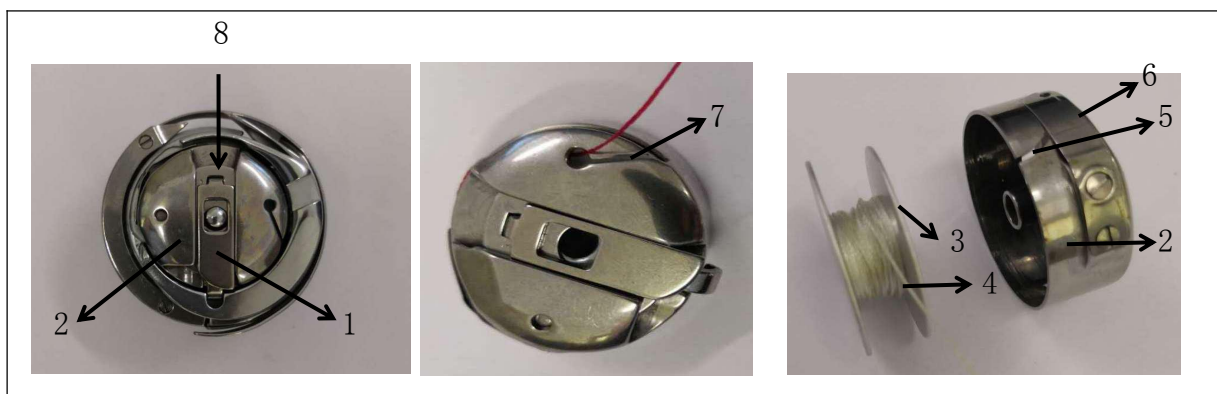

15 To thread upper thread

Let the take up lever (A) at its highest position. Then threading as shown in picture. Unwind a sufficient portion of thread, and pass it through the thread guide (1) and (2), then lead it through the tension assembly (3) and thread take up spring (4), thread guides (5) and (6) into the thread take up lever (A). Then downwards through the thread guide (7) to the thread guide (8) on the needle bar, and to the needle. Insert it into the needle hole from the front side to the rear side.

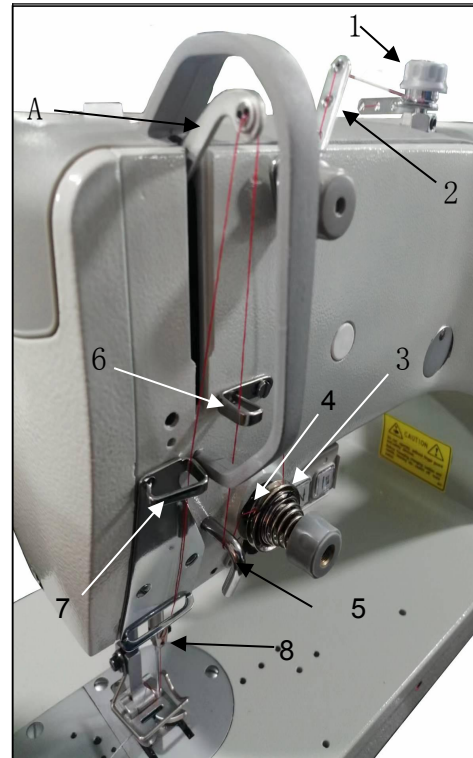

16 The thread tension adjustment

The tension of the upper and the lower thread must be interrelated that the stitch forming and the sewn material.

- To adjust the upper thread tension according to the lower thread tension. Turn the tension adjusting nut in clockwise to increase the tension, or inversely, to decrease it.
- To adjust the lower thread tension by turning adjusting screw A.
- It can adjust the take up spring to adjust upper thread tension for special sewn material and thread.

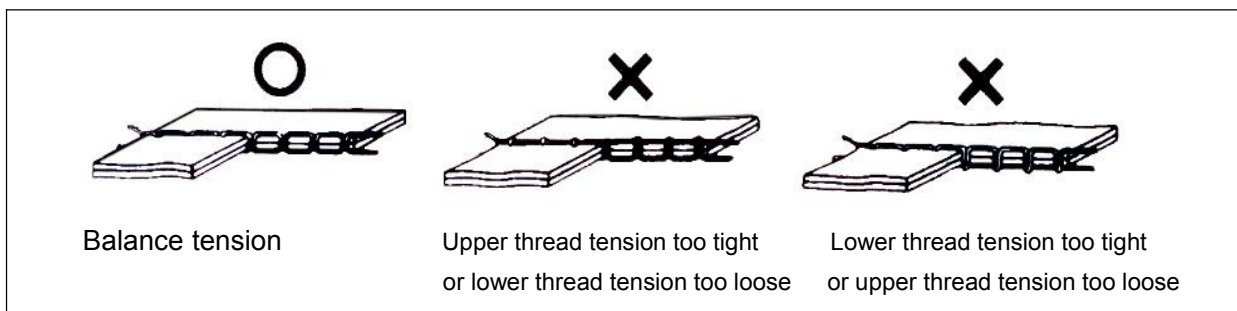
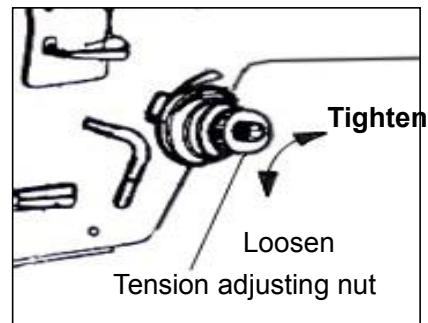
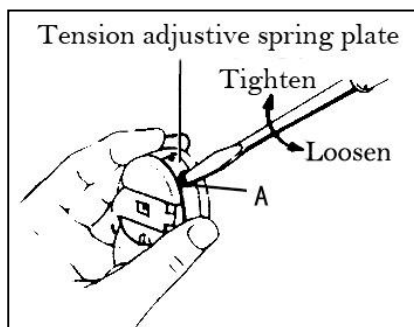

17 The thread take up spring tension adjustment

Loosen thread tension assembly screw (1), take away the thread tension assembly from machine to adjust the take up spring (4). Firstly loosen the screw (2) of bushing (3), and then adjust the angle position of lever (5). Turn it to left can decrease the elasticity of spring, or inversely, to increase it.

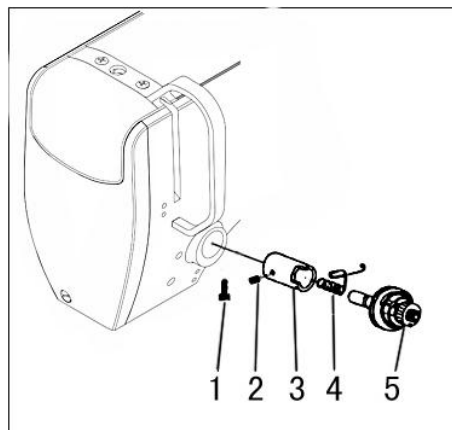

18 The presser foot pressure adjustment

- To adjust the presser foot pressure according to the sewn material.
- Adjustment as shown in picture.
- The pressure of sewing must to be adjusted as its min. value. But as same time, the pressure of presser foot must be sufficient to ensure reliable and continuous feeding even at the top speed.

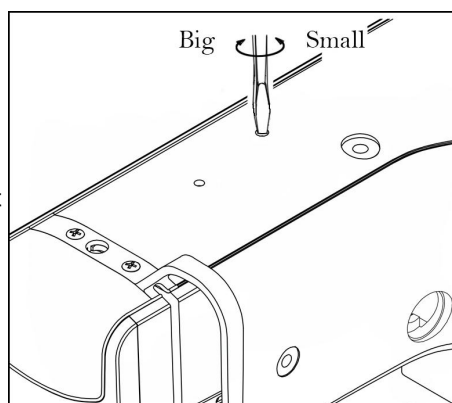

19 Stitch length setting mechanism

Regulation

If the zero stitch length is set, the hand lever should perform no lost motion.

- Loosen the screws (1)
- Set the setting knob (2) on the zero stitch length.
- Shift the lever (3) in the arrow direction until its fork is in bilateral contact with the screw spherical end on the knob (2) axis
- Tighten the screws (1).
- Check whether the backtacking lever (4) performs any lost motion in this position.

Zero stitch length

Regulation

If the zero stitch length is set, the connecting rod (3) should perform no motion.

- Set the stitch length knob on the zero cipher.
- Tilt the machine and loosen the screw (1).
- Shift the sleeve (2) until the position is found where the connecting rod (3) stops moving.
- Tighten the screw (1).

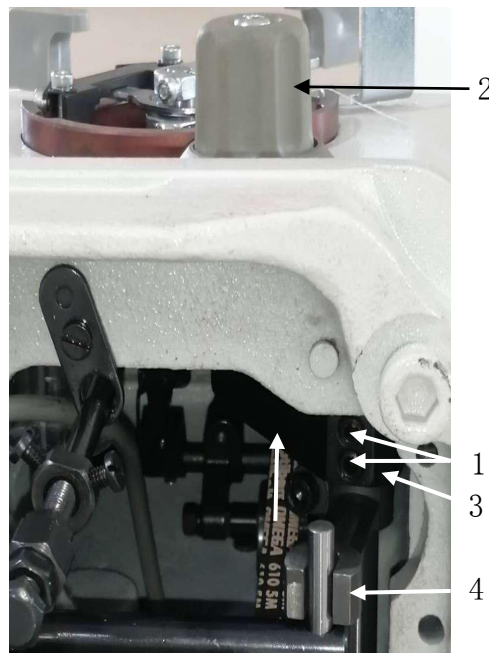

20 Setting of zig-zag stitch width (throw) and position

Attention!

At setting the zig-zag stitch width (throw) and position the needle must not be inside the sewn material. There is a threat of the needle breaking!

Setting of zig-zag stitch width

Press the lever (1) in the arrow direction (A) until it strikes the lever (2).

The lever arrest is released (2). Grip both levers at the same time and set the zig-zag stitch width by turning the lever (2) against the selected number indicating the stitch width.

→ Arrest the lever (2) position by turning the lever (1) against the arrow direction (A).

Setting of zig-zag stitch position

→ Press the lever (1) in the arrow direction (A) until it strikes the lever (2)-the lever arrest is released (3). Make sure that the lever setting does not change at the arrest switching off (2).

→ Press the lever (3) and turn it at the same time up to the stop (inside the machine) against the respective symbol indicating the zig-zag stitch position. Only the middle position of the lever is arrested with a lock.

→ After the lever (3) setting, carry out arresting with the lever (1).

→ In picture (B) there are examples of setting the zig-zag stitch width and position from which it is visible that the zig-zag stitch width does not change at the position change.

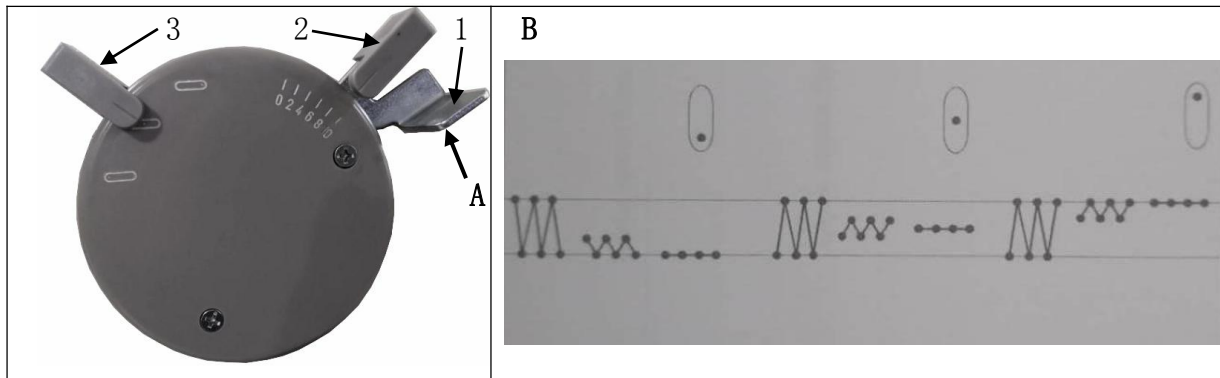

21 Tooth clearance setting of zigzag stitch gear

The tooth clearance of zigzag stitch should be as small as possible. No overlap instead of clearance, however, may arise in any mutual position of the gears.

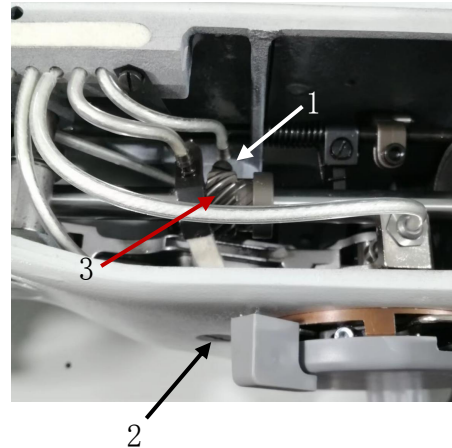

- Dismantle the machine top cover.
- Loosen the screw (1) and turn the eccentric bolt (2) until the gear fitted on it strikes the gear (3). With regard of the gear runout, caused by manufacturing inaccuracy, turn the hand wheel by 1/4 revolution, and set the clearance again. Repeat this 8 times (2 revolutions of the main shaft), until the eccentric bolt (2) position with the smallest tooth clearance is found. Locate the bolt (2) in this position and fix it with a screw (1).

22 Straight stitch alignment

The centrally positioned straight stitch must be fully aligned, i.e. the needle must not have any lateral motion.

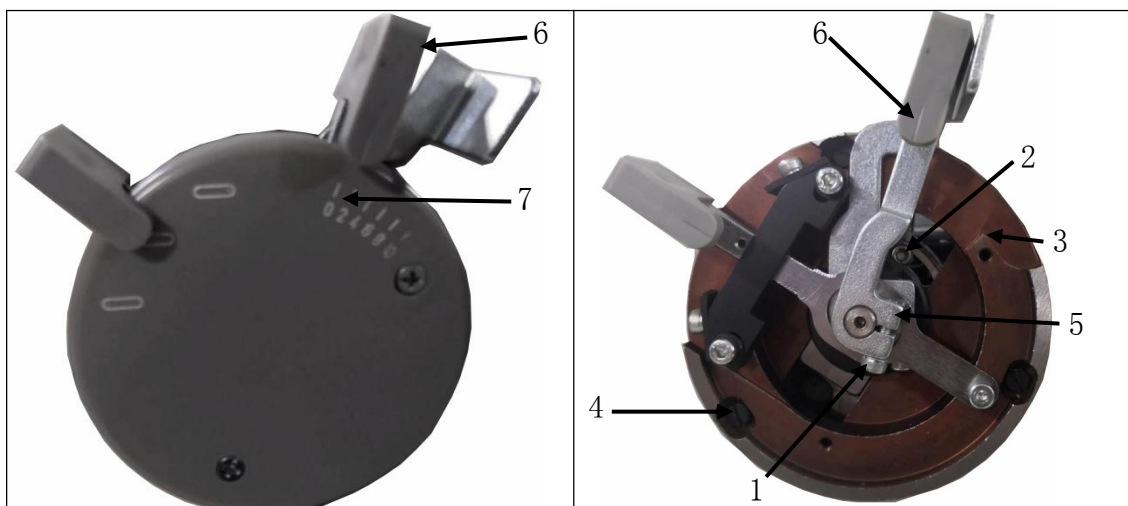

- Set the zero stitch length.
- Loosen the screw (1).
- Place the stop pin (2) to the stop onto the casing (3).
Place a piece of paper onto the throat plate and turn the hand wheel there and back until the needle point makes 2 holes in the paper.
- Loosen 3 screws (4) and try to set the casing (3) angle position until the needle, when being turned, stabs there and back in the same hole in the paper.
- Tighten the screws (4).

→ Fix the lever (5) so that the mark (6) is located opposite the zero on the zigzag stitch scale (7).

23 Zigzag stitch width

The zigzag stitch width setting must be limited to the value prescribed for the applied sewing equipment with the setting tolerance -5% of the prescribed value.

- Set the zero stitch length.
- Place a piece of paper onto the throat plate.
- Loosen the screw (1).
- Try to set the lever (2) in the position corresponding with the required zigzag stitch width. Turn the hand wheel there and back until the needle makes 2 holes in the paper. Measure their distance. Change the lever position (2) until the distance of the holes complies with the regulation.
- Shift the screw (1) to the stop and tighten it.

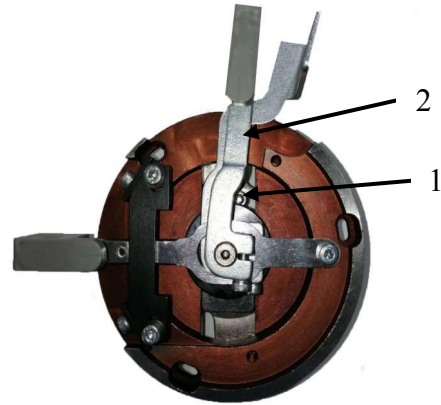

24 Needle stab position setting in feeding direction

If the needle is in the bottom dead center, it should be positioned in the throat plate needle hole center in feeding direction and its lost motion in the feeding direction should be as small as possible.

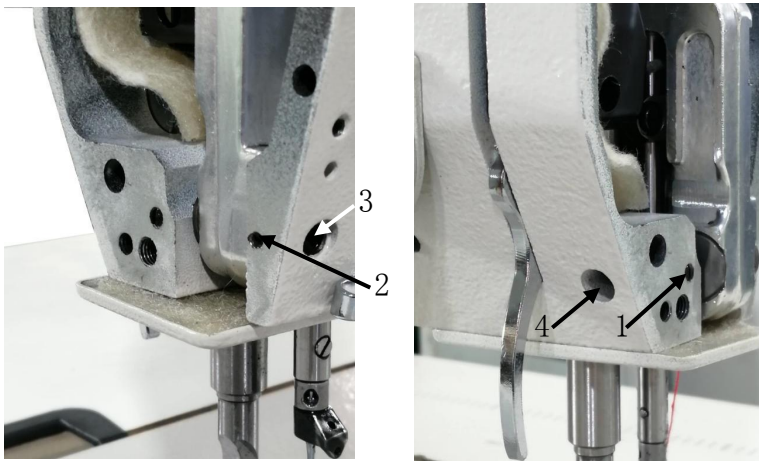

- Place the needle in the bottom dead center.
- Loosen the arresting screws (1),(2), and the regulating screw (3).
- Adjust the screw (4) so that the regulation is complied with and arrest it with the screw (1).
- Adjust the regulating screw (3) so that the lost motion (play) of the needle bar holder in the arrow direction is the smallest achievable one; rubbing must not occur.
- Tighten the screw (2).

25 Lateral setting of needle stab position

Both dead centers of the needle lateral motion at the zigzag stitch sewing should be at the same distance from the throat plate needle hole edges.

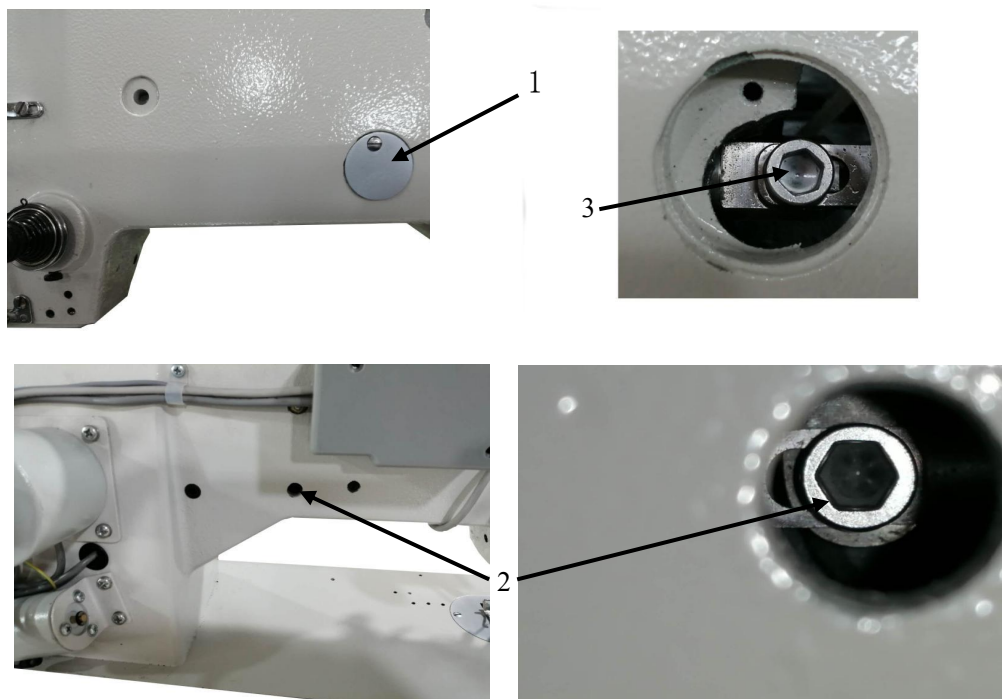

- Dismantle the cover (1) and the hole stop (2) from the rear side.
- Loosen both screws (3).
- Set the maximum zigzag stitch width and adjust the positions of the needle lateral motion dead centers as per regulation.
- Tighten both screws properly (3).

26 Lateral setting of central straight stitch position

If the central straight stitch is set, the needle position should be approximately in the center of the presser foot or in the middle of the throat plate needle hole center.

- Set the zero width of the zigzag stitch with the lever (1).
- Loosen the screws (2).
- Shift the lever (3) until the needle shifts in the lateral direction to the throat plate needle hole center.
- Tighten the screws (2).

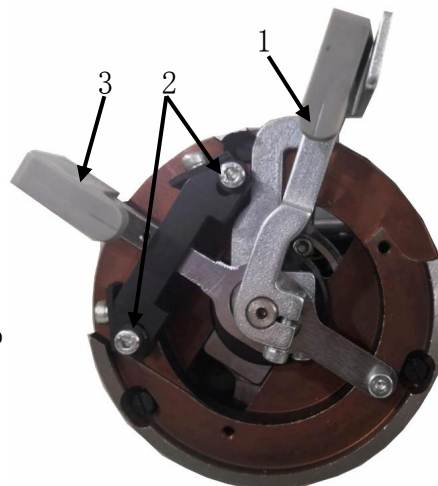

27 Lateral setting of straight stitches on throat plate needle hole edges, arresting of zigzag stitch setting mechanism

If the sewing equipment allows using the maximum zigzag stitch width, which is characteristic of the particular machine type, the position of the border straight stitches should be adjusted so that it aligns with the zigzag stitch border. If the throat plate needle hole is narrower than the maximum zigzag stitch width of the particular sewing machine type, the lever for the position setting of the border stitch must be fixed in the central position.

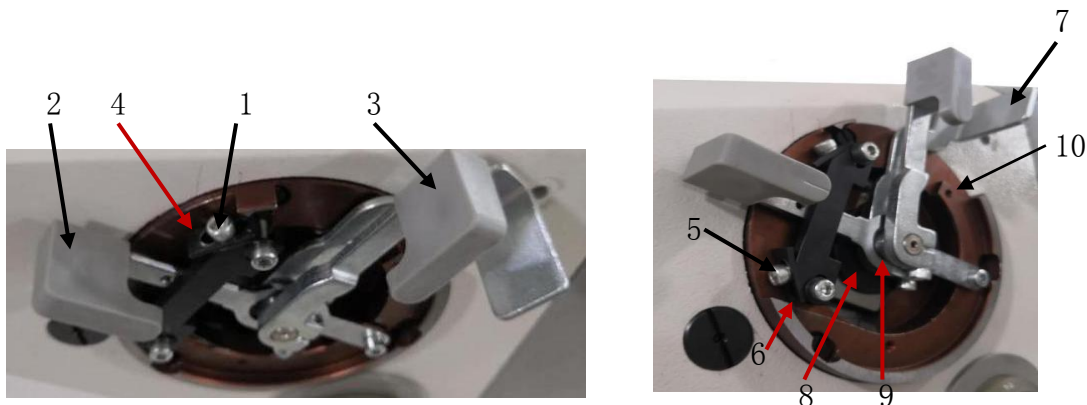

- Loosen the screw (1) and turn the lever (2) in the position, in which the needle will perform no lateral motion when turning the lever (3).
- Locate the stop (4) to the lever (2) and fix it with the screw (1).
- Loosen the screw (5) and turn the lever (2) to the position, in which the needle performs no side motion when moving the lever (3).
- Locate the stop (6) to the lever (2) and fix it with the screw (5).
- Adjust the arresting lever (7) in this position. Tighten the arresting nut (8-invisible), loosen the screw (9), turn the lever (7) to 1mm space from the casing (10) and tighten the screw (9).
- If the sewing equipment does not allow using the maximum zigzag stitch width, screw the regulating screw (11) into the lever (2) and fix it in the central position.

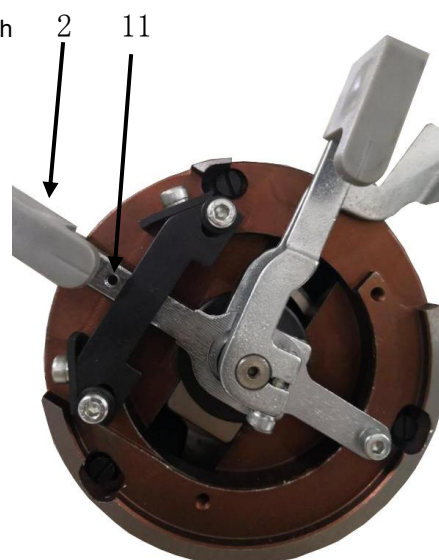

28 The gap between hook assembly and needle adjustment

Adjust the stitch forming width to zero and turning round the hand wheel towards the machine, when the needle goes up 2mm from the lowest position, the position of needle hole should be lower 1.6mm than hook top. The hook top position should be accordant with the centerline of needle and the gap from hook top to needle slot bottom should be 0.05mm.

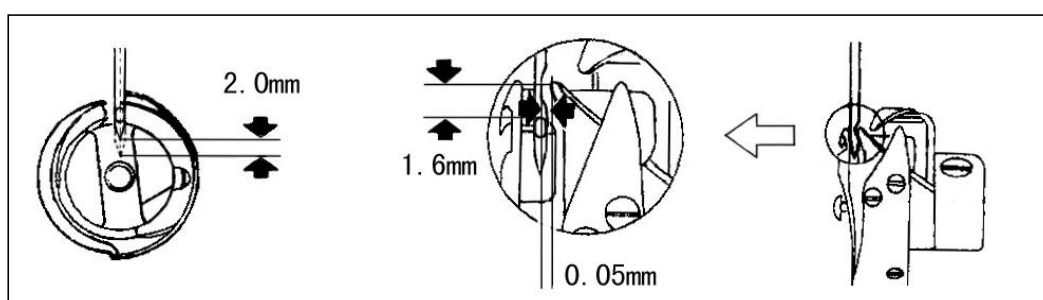

29 Bobbin case driver

The distance between the bobbin case driver and the bobbin case groove bottom should be (A)=0.7mm.

- Dismantle the throat plate and tilt the machine.
- Loosen the screw (1).
- Shift the driver (2) to the distance (A)=0.7mm.
- Tighten the screw (1).

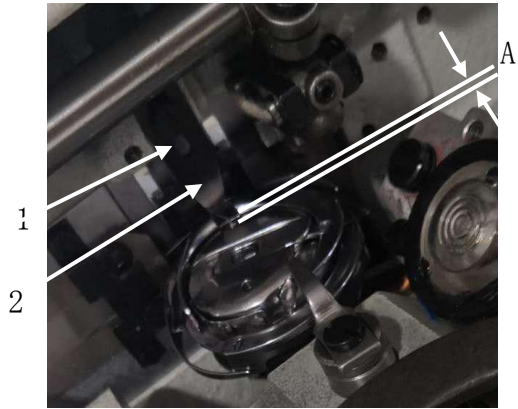

30 The feed dog height adjustment (see below picture)

The height of feed dog should be higher 1.0mm than needle plate. It is the standard for leaving factory.

The height of feed dog can be adjusted to 0.8-1.2mm according to sewn material. To adjust it, turn pulley Wheel to the highest position of feed dog, loosen the screw (2) of the lifting lever (8) on the shaft (6), adjust it to the required height of the feed dog and retighten the screw.

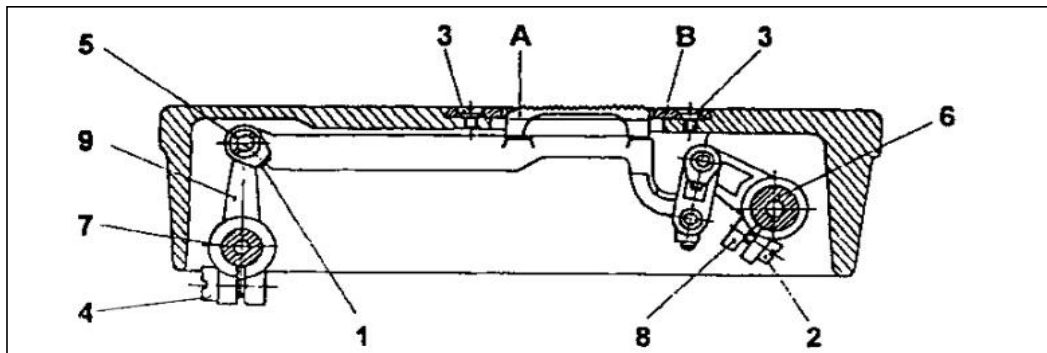

31 The feed dog obliquity adjustment (see above picture)

The standard position of feed dog is horizontal. It can be adjusted according to sewn material. To adjust it, loosen the screw (1) of the feeding lever (9) on the shaft (7), adjust the rear part of feed dog by correspondingly adjusting the position of eccentric pin (5), adjust it to the required height of the feed dog and retighten the screw.

32 Timing between needle and feed dog motion (see below picture)

When needle point A reaches needle plate top surface B, feed dog surface C should be keep accordant on height with needle plate top surface. It is the standard synchronous relationship. Adjusting method as below:

→ Orientation of lifting feed dog cam: see picture, lean the machine head backward, loosen screw (5), press lifting feed dog cam (6), turn pulley lightly, retighten the screw (5) when the angle becomes 90° between the orientation mark point of lifting feed cam with the groove of feed cam (7).

→ Loosen the synchronous pulley screw of lower shaft, turn the pulley in machine rotation direction till the needlepoint move downward to touch the top surface of needle plate. Then turn lower shaft in machine rotation direction, retighten the synchronous pulley screw when feed dog surface keep accordant on height with needle plate top surface.

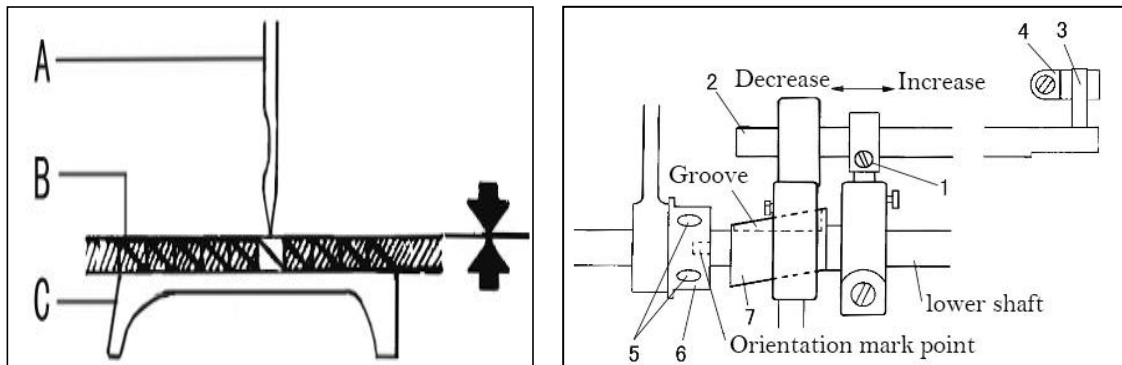

33 The forward/backward stitch length error adjustment (see above picture)

→ Adjust the forward/backward stitch length error through to adjust the position of the backstitch block on backstitch connection shaft.

→ Lean the machine head backward, loosen backstitch block screw (1). At same time, press backstitch pin (3) of backstitch connection shaft (2) in order to avoid it fall off backstitch control lever crank (4).

→ Backstitch length will be increased when remove backstitch block to right, and it will be decreased when remove backstitch block to left.

→ Retighten backstitch block screw (1) after the adjustment is well.

34 The position between hook and opener motion adjustment

→ Lean the machine head backward, screw out the bottom cover screw (1) of hook saddle, open bottom cover (2)

→ Put the needle bar to its lowest position.

→ Loosen thread finger cam screw (3), adjust thread finger cam (4), make thread finger site on the nearest position of hook, and then retighten thread finger cam screw.

→ Loosen hook opener screw (5), adjust the distance between thread finger and hook is 0.3~0.4mm.

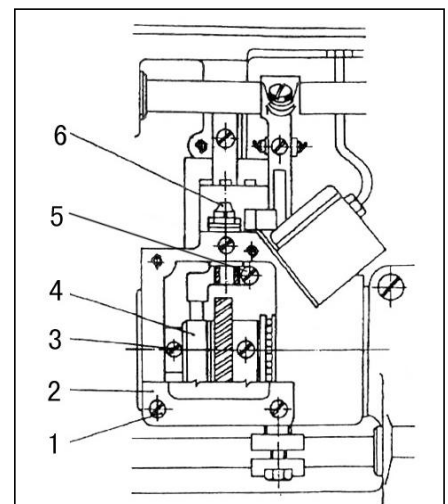

35 Form stitch of patterns cam series

The setting should be carried out in the sequence as described herein.

a Tooth clearance setting of form stitch gear

The tooth clearance of the form stitch gear should be as small as possible. No overlap instead of clearance, however, may arise in any mutual position of the gears.

- Dismantle the top cover.
- Turn the hand wheel 12 times in intervals of approximately 1/3 revolution and ascertain the tooth clearance, turning the steering cam (1) manually until the position with the smallest tooth clearance is found.
- Loosen the screws (2), turn the gear in the smallest tooth clearance position, shift the cone scroll (3) to the right and set the tooth clearance as small as possible. Tighten the screws (2).
- Mount the regulating ring (4) on touch with the scroll (3).
- Check the tooth clearance.

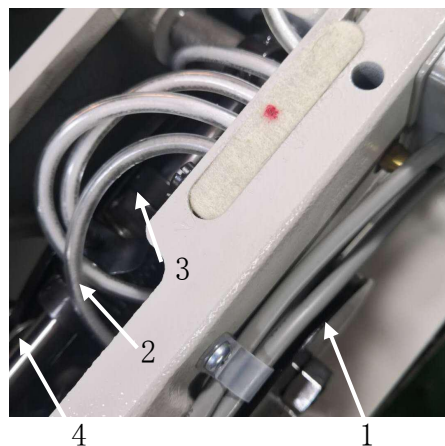

b Roller bolt position of form stitch steering cam

When changing the form stitch width, the stitch central axis should remain in its place. It should not shift laterally.

- Mount the wheel steering cam of the straight stitch (from the machine rear side)
- Dismantle the cover of the form stitch width setting mechanism.
- Release the bolt (1) position by tilting the lever (2) in yourself direction.

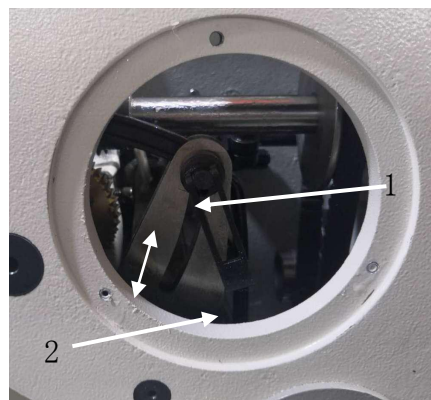

- Move the bolt (1) in the arrow direction and watch whether the needle is moving laterally. If yes, dismantle the steering cam, loosen the screw (3) and try to turn the eccentric bolt (4) to a different position and test whether the needle is changing its position. Repeat this until the eccentric bolt (4) position is found where the needle position does not change.
- Tighten the screw (3).



C Setting of needle stab position

If the wheel steering cam of the straight stitch is mounted, the needle should be located in both directions in center of the throat plate needle hole.

- Adjust the needle position in feeding direction as per section 24
- Adjust the needle lateral position similarly as in section 25 so that the needle is located in the needle hole center.

D Timing of form stitch steering cam to needle motion

When sewing the form stitch, the needle should shift in the lateral direction at the time when it is over the sewn material.

- Dismantle the top cover.
- Mount any form stitch cam (1).
- Loosen 4 screws (2) and turn the scroll (3) to the position where the regulation is complied with. Put the scroll (3) on touch with the regulating ring (4) and fix it.
- Check whether the needle is without any motion at the time when it is stabbed in the sewn material and adjust the setting, if needed.

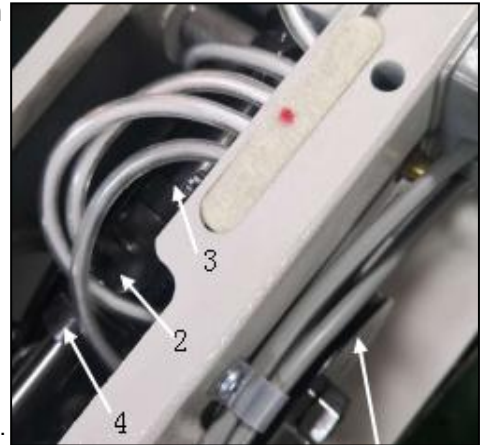

1

36 Form stitch of patterns cam with part number

NO. OF STITCHES	70206059	70206060	70206061	70206062	70206063	70206064	70206065
SEWING PATTERNS							
NO. OF STITCHES	70206066	70206067	70206068	70206069	70206070	70206071	70206072
SEWING PATTERNS							

37 Backtacking with solenoid

At the maximum stitch length, at the backtacking mechanism dislocation with the solenoid, its movable core should not strike the fixed one.

- Set the maximum stitch length.
- Press the backtacking lever down to the stop and hold it in this position.
- Loosen the screw (1), press the lever (2) down to the stop, and put it back by approximately 1mm.
- Tighten the screw (1).
- Test whether its movable core does not strike the fixed one when the solenoid is switched on.

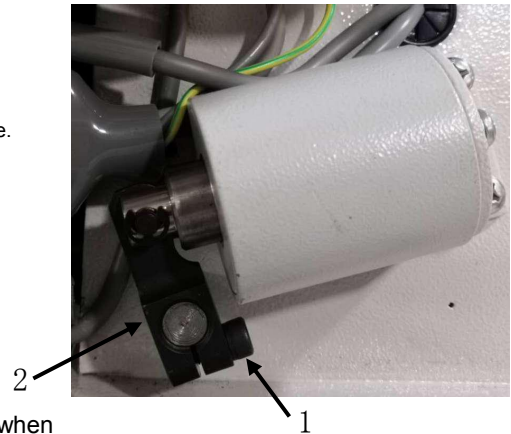

38 Presser foot lifting

A Manual foot lifting

Regulation

The foot stroke with the hand lever should be 5.5mm.

- Place the bottom feed dog under the level of the throat plate top surface.
- Place an object of thickness 5.5mm under the foot.
- Loosen the screw (1), lift the hand lever (2), press the driver (3) down to the lever (2) and tighten the screw (1).

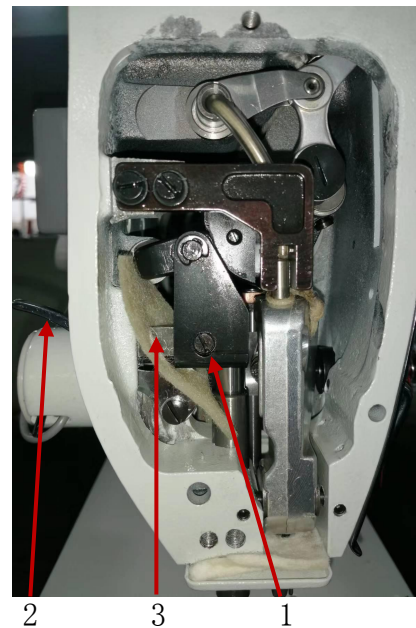

B Foot lifting with knee lever

Regulation

The foot stroke with the knee lever should be 12.5mm, the space (A) = approximately 2mm if the knee lever is in the initial position.

- Lower the presser foot on the throat plate.
- Loosen the screw (1) and turn the lever (2) so that there is no space (A).
- Tighten the screw (1).
- Try to adjust the ring (3) position and test how big the foot stroke with the knee lever is. Repeat this until the prescribed foot lifting is achieved.

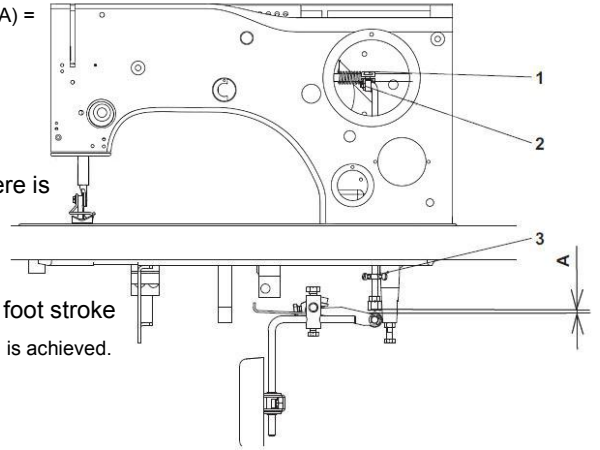

C Foot lifting with solenoid

Regulation

The foot stroke with the solenoid is 12mm.

If the foot is lifted, the solenoid movable core should be at the stop onto the fixed core.

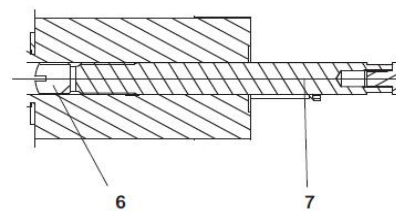
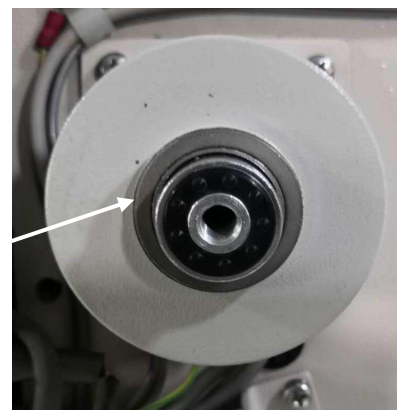
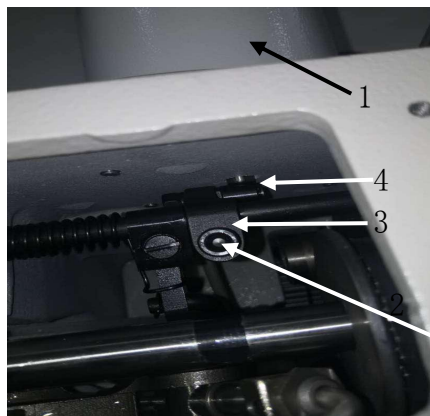

- Place the foot onto the throat plate.
- Unscrew the solenoid (1) nut.
- Loosen the screw (2).
Turn the lever (3) with the roller (4) almost on touch with the side, and tighten the screw (2).
- Remove the solenoid core (5).
- Loosen the screw (6) and try to turn the screw (7) to any position.
- Insert the core (5) back in the solenoid, press it down and find out how big the solenoid stroke is. Repeat the procedure until the prescribed value is achieved.
- Lock the screw (7) position with the screw (6).

39 Bobbin winder

Regulation

If the bobbin winder is switched off, the space between the driving and driven wheels of the bobbin winder should be as small as possible, but they must not touch each other.

When winding the thread, the bobbin winder should automatically switch off when the thread is wound up to 0.5mm under the bobbin outer diameter.

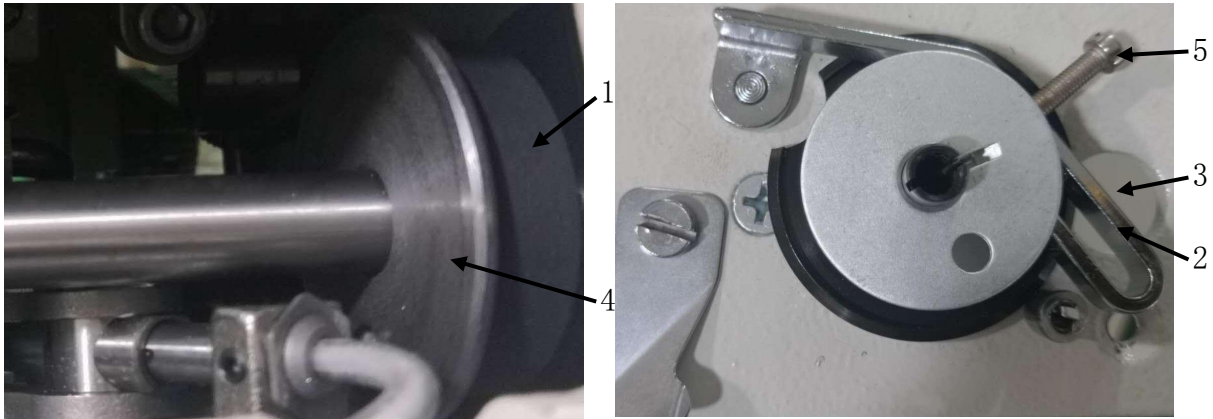

- Dismantle the machine arm top cover.
- Shift the indented belt (1) with a screwdriver so that two screws of pulley are accessible and loosen them.
- Mount the machine arm top cover and switch off the bobbin winder with the lever (2).
- Insert a hexagonal key through the hole (3) into the screw of the pulley and shift the indented belt pulley (4) to the left up to the stop. Afterwards shift it by 0.5mm to the right and tighten the screw. Then tighten also the other belt pulley fixing screw.
- Adjust the switch lever with the screw (5) and test whether the adjustment complies with the regulation.

40 Thread trimming

A Trimming pressure between knives

Regulation

The trimming pressure should be as large as possible, however, the knives should be on touch within the last part of the trimming knife path only.

- Tilt the machine, loosen the screw (1), and remove the bolt (2).
- Set a high pressure between the trimming knives with the screw (3) so that the resistance against the knife motion is high within the whole motion path.
- Gradually reduce the knife pressure with the screw (3) until compliance with the regulation is achieved.
- Mount the bolt (2) back again.

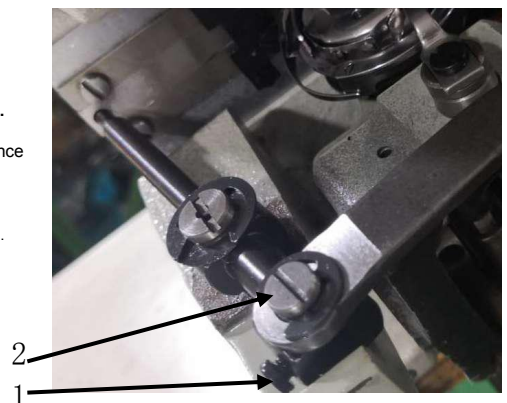
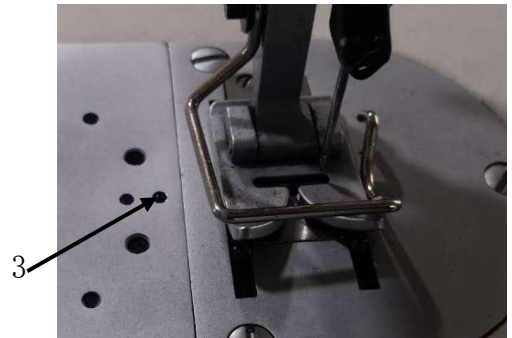

B Trimming lever

Regulation

The trimming lever (6) should be located as high as possible, but it should not rub the plate (5). The eccentric bolt (2) groove should be in horizontal position.

- Tilt the machine.
- Loosen the screw (3) and turn the eccentric bolt (4) so that the lever does not rub (6) the plate (5), however, it should be positioned as high as possible. Tighten the screw (3).
- Loosen the screw (1). Turn the eccentric bolt (2) so that its groove is almost horizontally positioned. Tighten the screw (1).

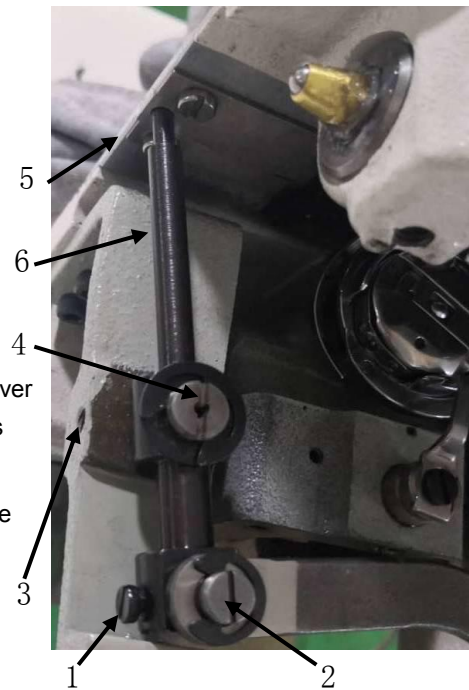

C Driver

Regulation

If the driver (1) touches the casing (2), the knife (3) should be on the plate edge (4).

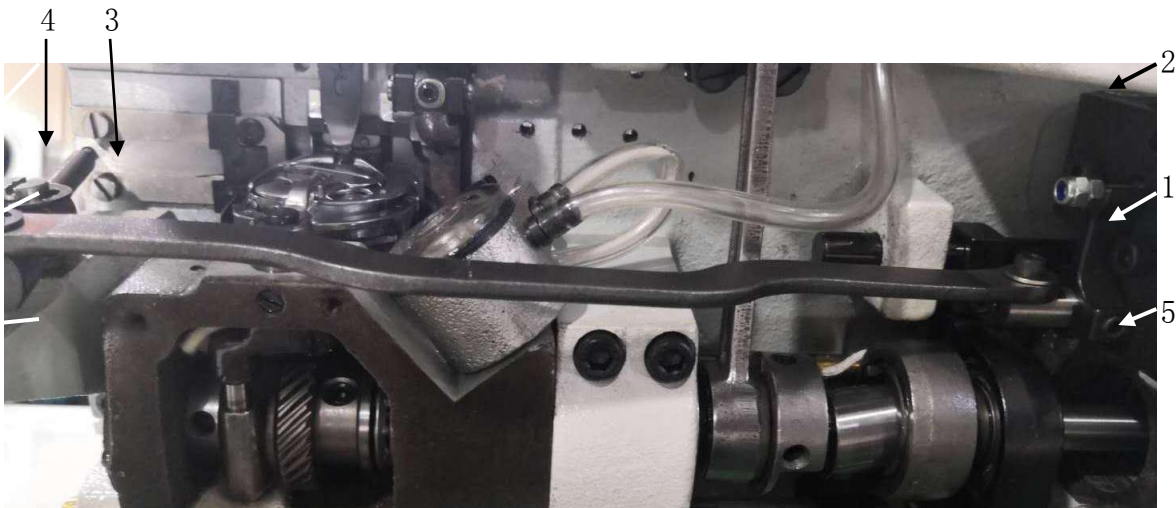

- Tilt the machine.
- Loosen the screw (5).
- Shift the knife (3) as per regulation.
- Place the driver (1) on touch with the casing (2) and tighten the screw (5).

D Trimming cam

Regulation

If the trimmer is not active, then the shortest distance between the cam (3) and roller (4) should be 0.1mm.

Timing of the cam: if the needle point is approximately (A) = 1mm over the throat plate, the cam screws should be turned downwards and their axes perpendicularly to the machine base plate.

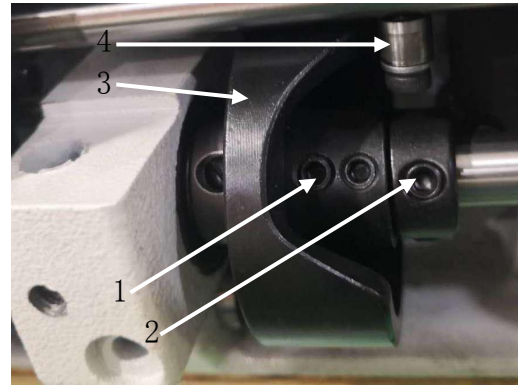
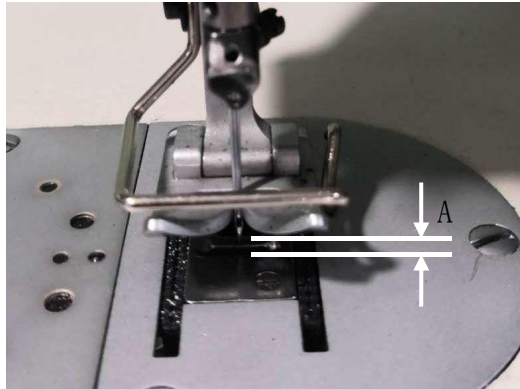

- Tilt the machine.
- Loosen the screws (1) and (2), set the distance 0.1mm by shifting the cam (3) and tighten the screws (1).
- Put the ring (5) on touch with the cam (3) and tighten the screws (2).
- Loosen the screws (1).
- Set the needle point to the distance (A) = 1mm.
- Set the cam (3) with the screws (1) downwards as per regulation and tighten them.

41 Electronic control and machine drive

Refer to the electronic control instruction to be delivered with the machine.

ZZ-2565/2567/2568 AUT SERIES

PARTS LIST

CONTENT

A. Arm bed and its accessories	2
B. Bobbin winder and Thread tension parts	4
C. Arm shaft and needle bar thread take up parts	6
D. Needle bar vibrating parts	10
E. Needle bar vibrating parts	12
F. Presser foot parts	14
G. Stitch length adjustment and backstitch parts	16
H. Lower shaft, feed dog and presser foot lifting parts ...	18
I. Hook assembly	20
J. Hook assembly (Small hook)	22
L. Thread trimming parts	24
M. Tension release, electrocircuit board, oil circuit parts	26
N. Automatic drive parts	28
O. Special parts for cam patterns zigzag machine	30
P. Accessories	32

A. Arm bed and its accessories

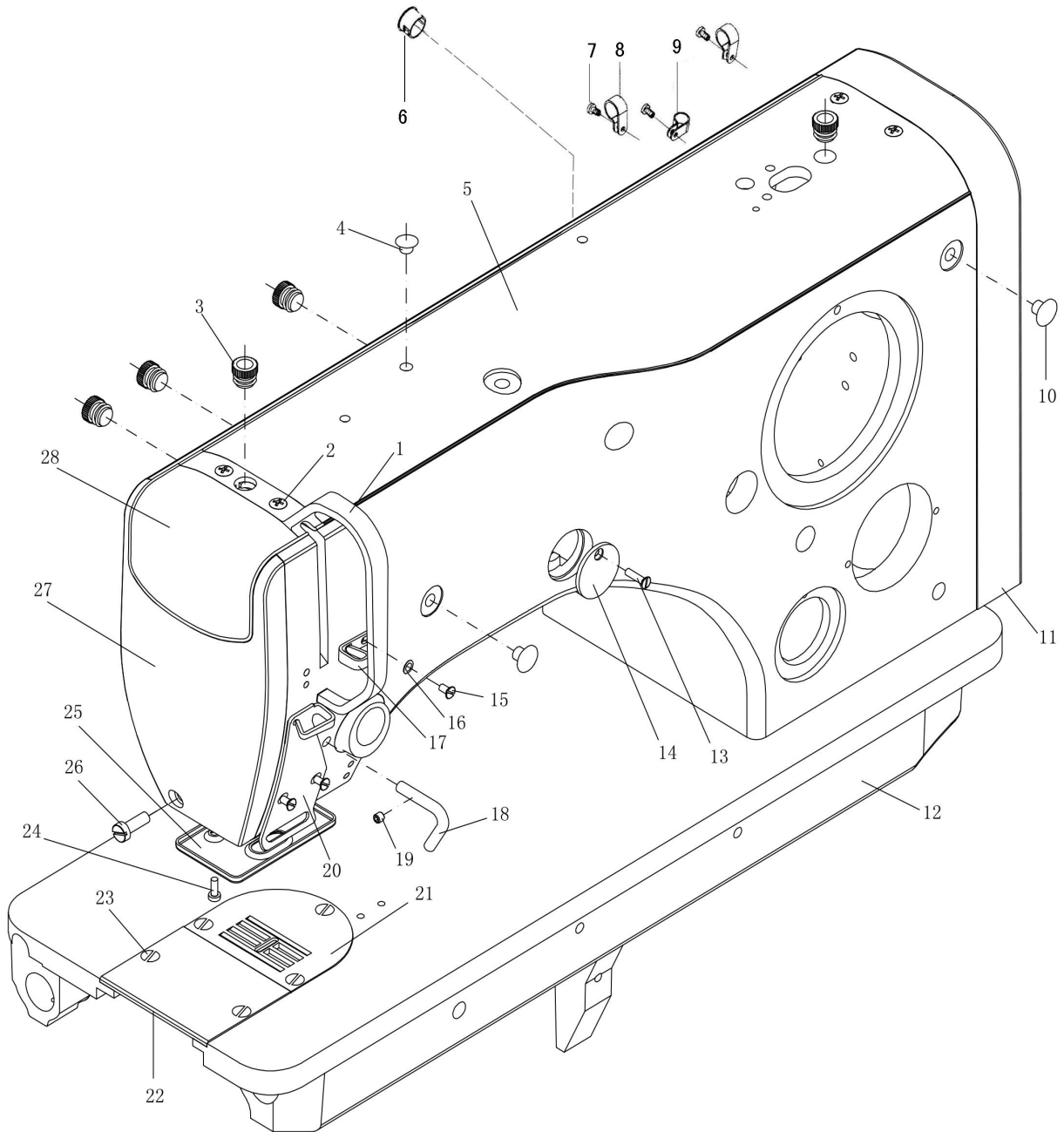

A. Arm bed and its accessories

No.	Part No.	Name	Qty	
			ZZ-2568 AUT	ZZ-2567 AUT
A01	7.02.11.589	Thread take up lever guard cover	1	1
A02	7.02.15.1087	Screw	4	4
A03	7.02.16.058	Plastic plug	5	5
A04	7.02.16.559	Rubber plug	1	1
A05	7.02.11.587	Upper cover plate	1	1
A06	7.02.16.500	Line card	1	1
A07	7.02.15.1080	Upper clip of supply cord screw	3	3
A08	7.02.16.167	Upper clip of supply cord	3	3
A09	7.02.16.166	Upper clip of supply cord		
A10	7.02.16.501	Plastic block	2	2
A11	7.02.16.526	Belt cover	1	1
	7.02.15.444	Belt cover screw	3	3
A12	7.01.01.109	Casting	1	1
A13	7.02.15.393	Screw	1	1
A14	7.02.11.063	Round cover plate	1	1
A15	7.02.15.392	Screw	3	3
A16	7.02.18.070	Washer	1	1
A17	7.02.14.028	Thread guide plate	1	1
A18	7.02.14.025	Thread guide lever(lower)	1	1
A19	7.02.15.047	Screw	1	1
A20	7.02.14.035	Lower thread guide plate	1	1
A21	7.02.02.086	Needle plate		1
	7.02.02.079	Needle plate	1	
	7.02.02.628	New type needle plate for thin material		
A22	7.02.02.085	Slide plate (special used for no thread cutting)		
A23	7.02.15.388	Needle plate screw	5	5
A24	7.02.15.390	Screw	1	1
A25	7.02.11.062	Oil surface tray	1	1
A26	7.02.15.389	Screw	2	2
A27	7.02.11.588	Face plate	1	1
A28	7.01.16.527	Face plate cover	1	1

B. Bobbin winder and thread tension parts

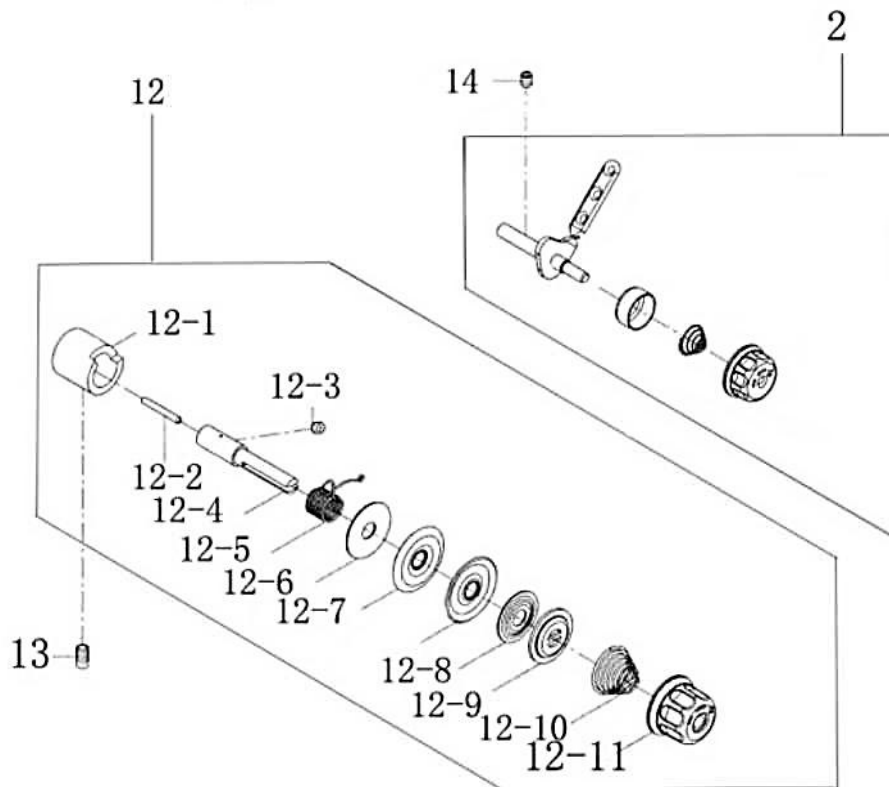
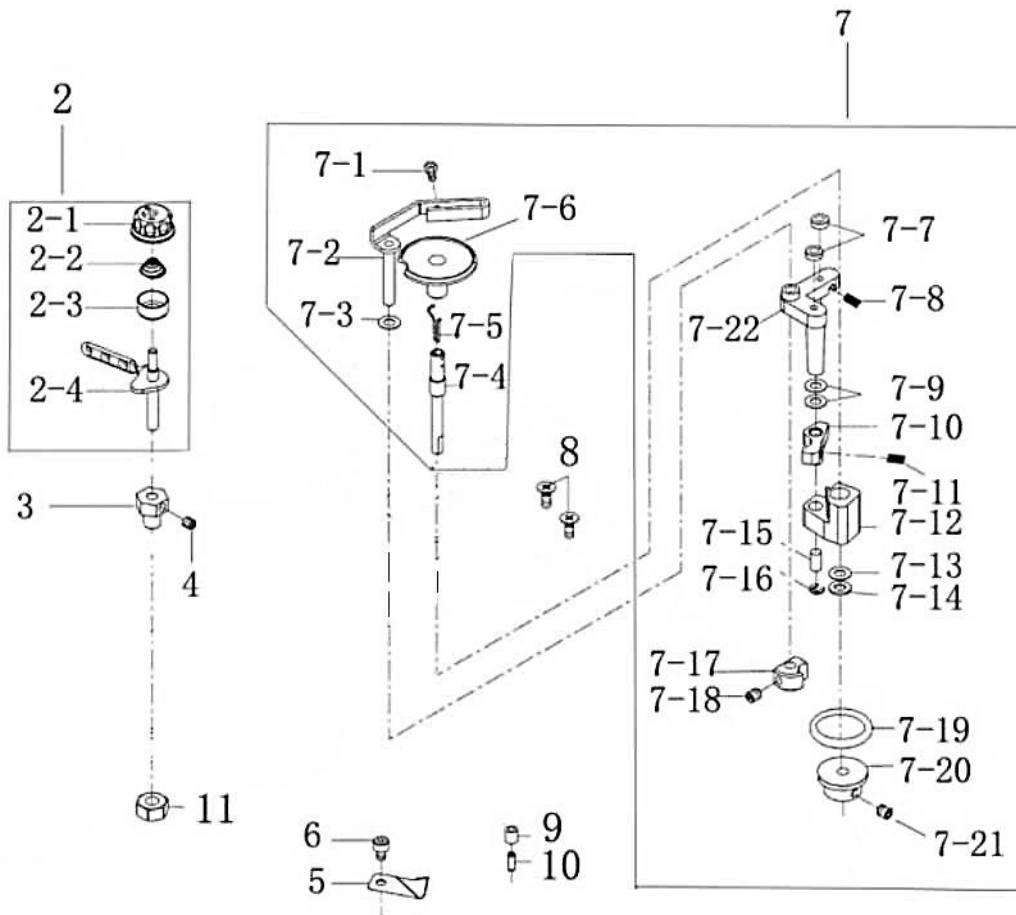

B. Bobbin winder and thread tension parts

No.	Part No.	Name	Qty	
			ZZ-2568 AUT	ZZ-2567 AUT
B02	7.02.01.210	Top cover thread tension assy.	2	2
2-1		Regulating handle	2	2
2-2		Spring	2	2
2-3		Tension disc	2	2
2-4		Thread guide lever	2	2
B03	7.02.08.369	Thread tension plate bushing	1	1
B04	7.02.15.056	Screw	1	1
B05	7.02.20.070	Thread winder thread cutter	1	1
B06	7.02.15.1031	Thread cutter screw	1	1
B07	7.02.01.213	Thread winder assy.	1	1
7-1		Screw	1	1
7-2		Thread winder stopper rod	1	1
7-3		Washer	1	1
7-4	7.02.23.373	Bobbin winder lever	1	1
7-5	7.02.23.081	Stopper spring	1	1
7-6		Lock core disc	1	1
7-7	7.02.08.368	Bushing	2	2
7-8		Spring	1	1
7-9		Washer	2	2
7-10		Stopper link	1	1
7-11		Spring	1	1
7-12		Connecting seat	1	1
7-13		Washer	1	1
7-14		Washer	1	1
7-15		Bushing	1	1
7-16		Retainer ring	1	1
7-17		Stopper block	1	1
7-18		Screw	1	1
7-19	7.02.23.087	Rubber ring	1	1
7-20		Rubber ring seat	1	1
7-21		Screw	1	1
7-22		Thread winder and tension bracket base	1	1
B08	7.02.15.1087	Thread winder mounting screw	2	2
B09	7.02.08.362	Pin bushing	1	1
B10	7.02.10.302	Pin	1	1
B11	7.02.15.1030	Nut	1	1
B12	7.02.01.038	Thread tension assy.	1	1
12-1		Thread tension base	1	1
12-2	7.02.10.088	Thread releasing pin	1	1
12-3		Screw	1	1
12-4		Support rod	1	1
12-5	7.02.23.060	Thread take up spring	1	1
12-7		Thread tension plate	2	2
12-8		Clamp plate	1	1
12-9		Tension releasing plate	1	1
12-10		Tension spring	1	1
12-11	7.02.16.502	Tension spring regulating handle	1	1
B13	7.02.15.006	Screw	1	1
B14	7.02.15.1065	Screw	2	2
	7.02.23.294	Block of bobbin winder (plastic in white color)	1	1

C. Arm shaft and needle bar thread take up parts

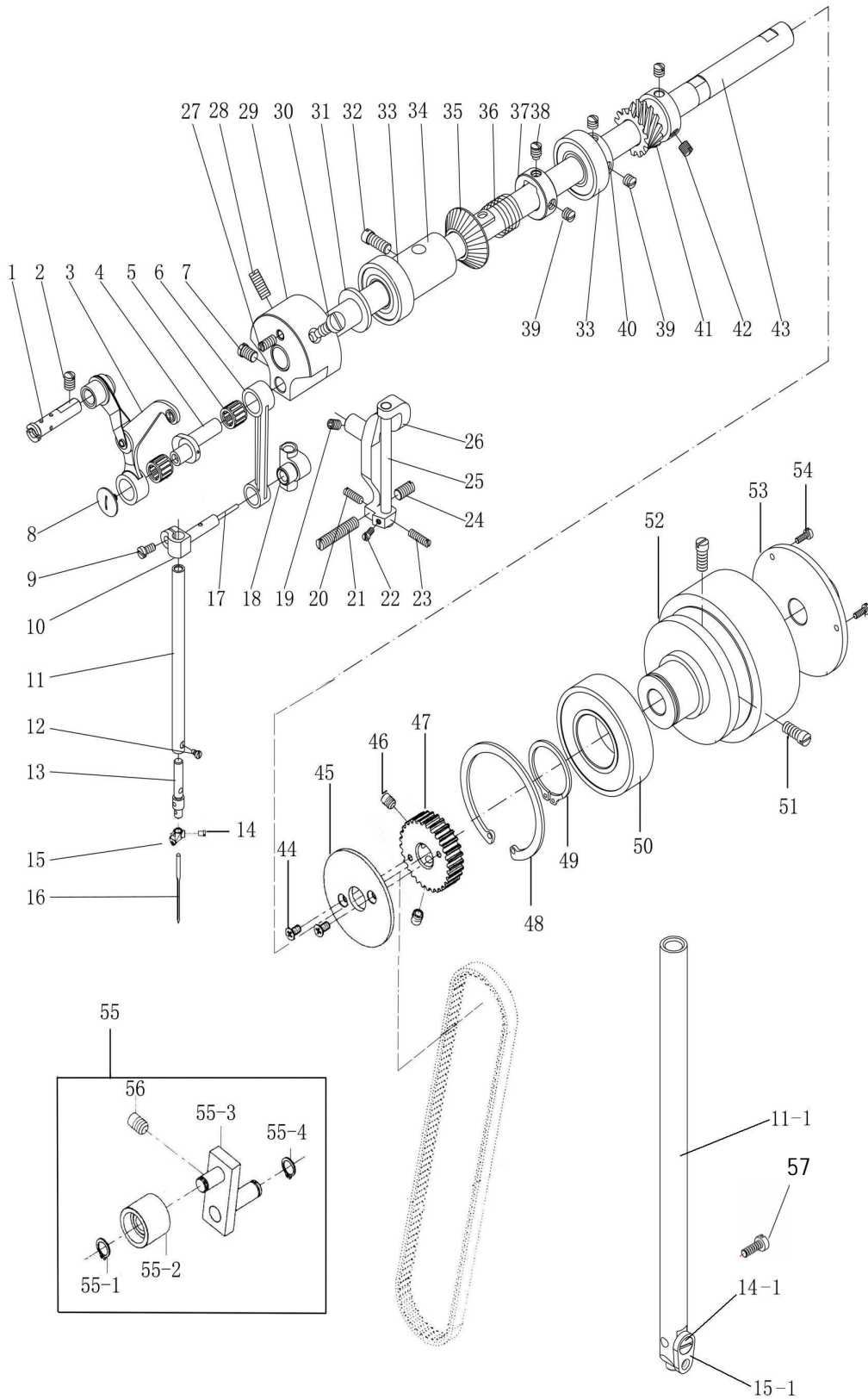

C. Arm shaft and needle bar thread take up parts

No.	Part No.	Name	Qty	
			ZZ-2568 AUT	ZZ-2567 AUT
C01	7.02.10.091	Thread take up lever support stud	1	1
C02	7.02.15.411	Thread take up lever support stud screw	1	1
C03	7.02.05.066	Thread take up lever assy	1	1
	7.02.05.530	Thread take up lever assy(ZZ-2565/2565 AUT)		
C04	7.02.06.036	Libra crank	1	1
	7.02.06.087	Libra crank(ZZ-2565/2565 AUT)		
C05	7.02.04.025	Bearing	2	2
C06	7.02.05.067	Needle bar link	1	1
C07	7.02.15.395	Libra crank screw	1	1
C08	7.02.15.413	Thread take up crank screw	1	1
C09	7.02.15.408	Needle bar joint screw	1	1
C10	7.02.02.088	Needle bar joint	1	1
C11	7.02.03.071	Needle bar		
	7.02.03.272	Needle bar (lengthen)		
C-11-1	7.02.03.497	Needle bar (New)	1	
	7.02.03.278	Needle bar (New) (lengthen)		1
C12	7.02.15.409	Needle clamp shaft screw		
C13	7.02.10.090	Needle clamp shaft		
C14	7.02.15.412	Screw		
C14-1	7.02.15.1140	Screw (New)	1	1
C15	7.02.14.033	Needle clamp washer		
C15-1	7.02.14.034	Needle clamp washer (New)	1	1
C16	7.02.21.140	Needle	1	1
C17		Needle bar connection wick	1	1
C18	7.02.05.065	Needle bar connection holder	1	1
C19	7.02.15.056	Needle bar connection bracket tighten screw	1	1
C20	7.02.15.400	Needle bar connection bracket screw (back)	1	1
C21	7.02.15.401	Needle bar connection bracket screw (left)	1	1
C22	7.02.15.037	Needle bar connection bracket shaft screw	1	1
C23	7.02.15.404	Needle bar connection bracket screw (front)	1	1
C24	7.02.15.403	Needle bar connection bracket screw (right)	1	1
C25	7.02.10.089	Needle bar connection bracket shaft	1	1
C26	7.02.05.064	Needle bar connection bracket	1	1
C27	7.02.15.396	Tighten screw	1	1
C28	7.02.15.397	Needle bar crank tighten screw	1	1
C29	7.02.06.035	Needle bar crank	1	1
	7.02.06.094	Needle bar crank(ZZ-2565/2565 AUT)		
C30	7.02.15.398	Needle bar crank orientation screw	1	1
C31	7.02.16.090	Felt	1	1

C. Arm shaft and needle bar thread take up parts

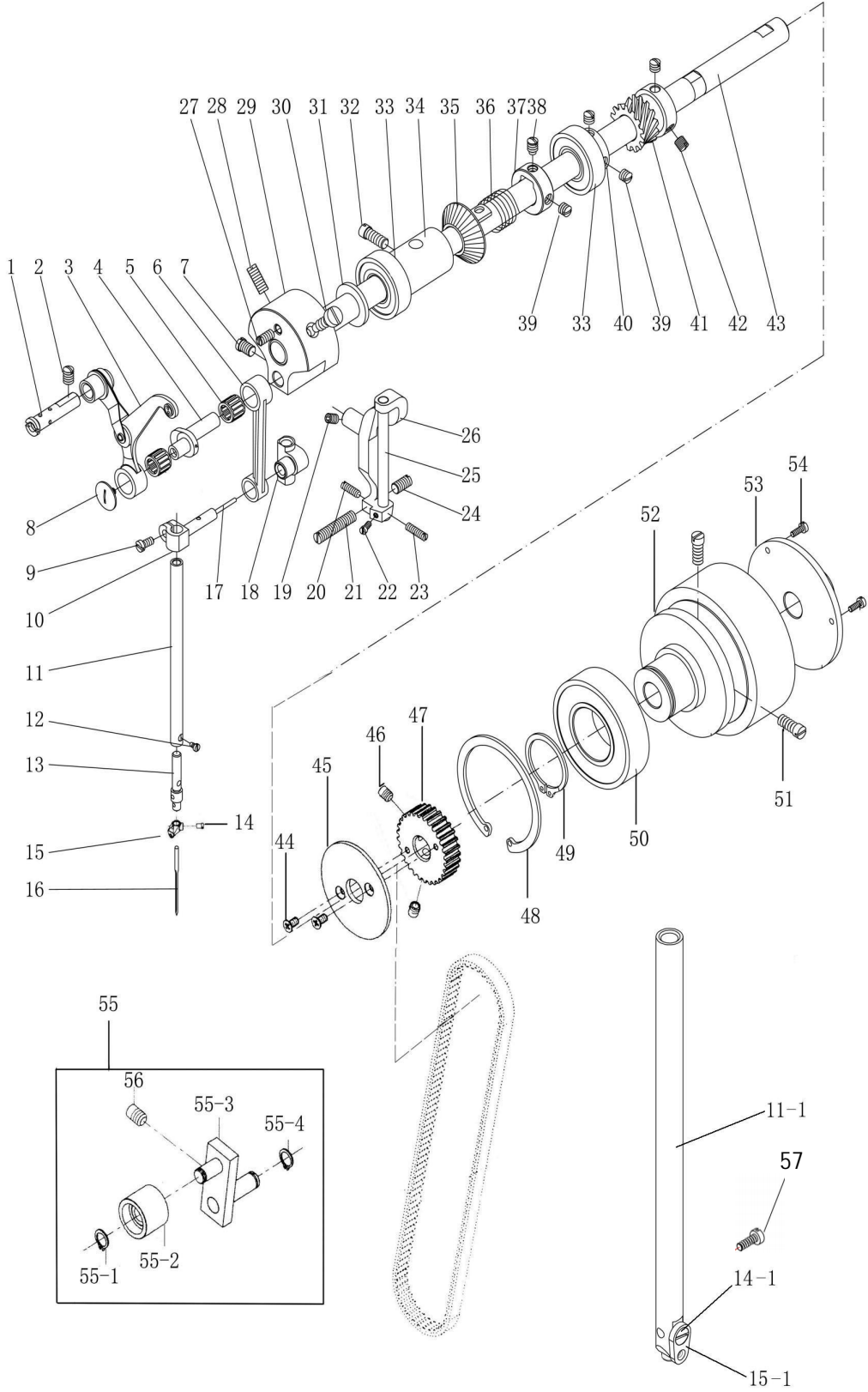

C. Arm shaft and needle bar thread take up parts

No.	Part No.	Name	Qty	
			ZZ-2568 AUT	ZZ-2567 AUT
C32	7.02.15.399	Arm shaft bushing screw	1	1
C33	7.02.04.024	Arm shaft bearing	2	2
C34	7.02.08.095	Arm shaft bushing	1	1
C39	7.02.15.428	Collar screw	2	2
C40	7.02.08.102	Arm shaft bearing collar	1	1
C41	7.02.07.051	Vibrating needle drive gear	1	1
C42	7.02.15.126	Small gear screw	3	3
C43	7.02.03.490	Arm shaft	1	1
C44	7.02.15.797	Stopper plate screw	2	2
C45	7.02.11.224	Stopper plate	1	1
C46	7.02.15.052	Screw	2	2
C47	7.02.07.195	Synchronous pulley (upper)	1	1
C48	7.02.18.076	Elastic stop ring	1	1
C49	7.02.18.078	Elastic stop ring	1	1
C50	7.02.04.027	Arm shaft bearing (right) Bearing	1	1
C51	7.02.15.399	Pulley mounting screw	2	2
C52	7.02.07.054	Pulley	1	1
C53	7.02.11.064	Pulley cover	1	1
C54	7.02.15.432	Pulley cover screw	3	3
C55	7.02.01.211	Tension wheel assy.	1	1
55-1		Retainer ring	1	1
55-2		Friction pulley	1	1
55-3		Tension wheel base	1	1
55-4	7.02.18.145	Retainer ring	1	1
C56		Screw	1	1
C57	7.02.15.019	Screw	1	1

D. Needle bar vibrating parts (一)

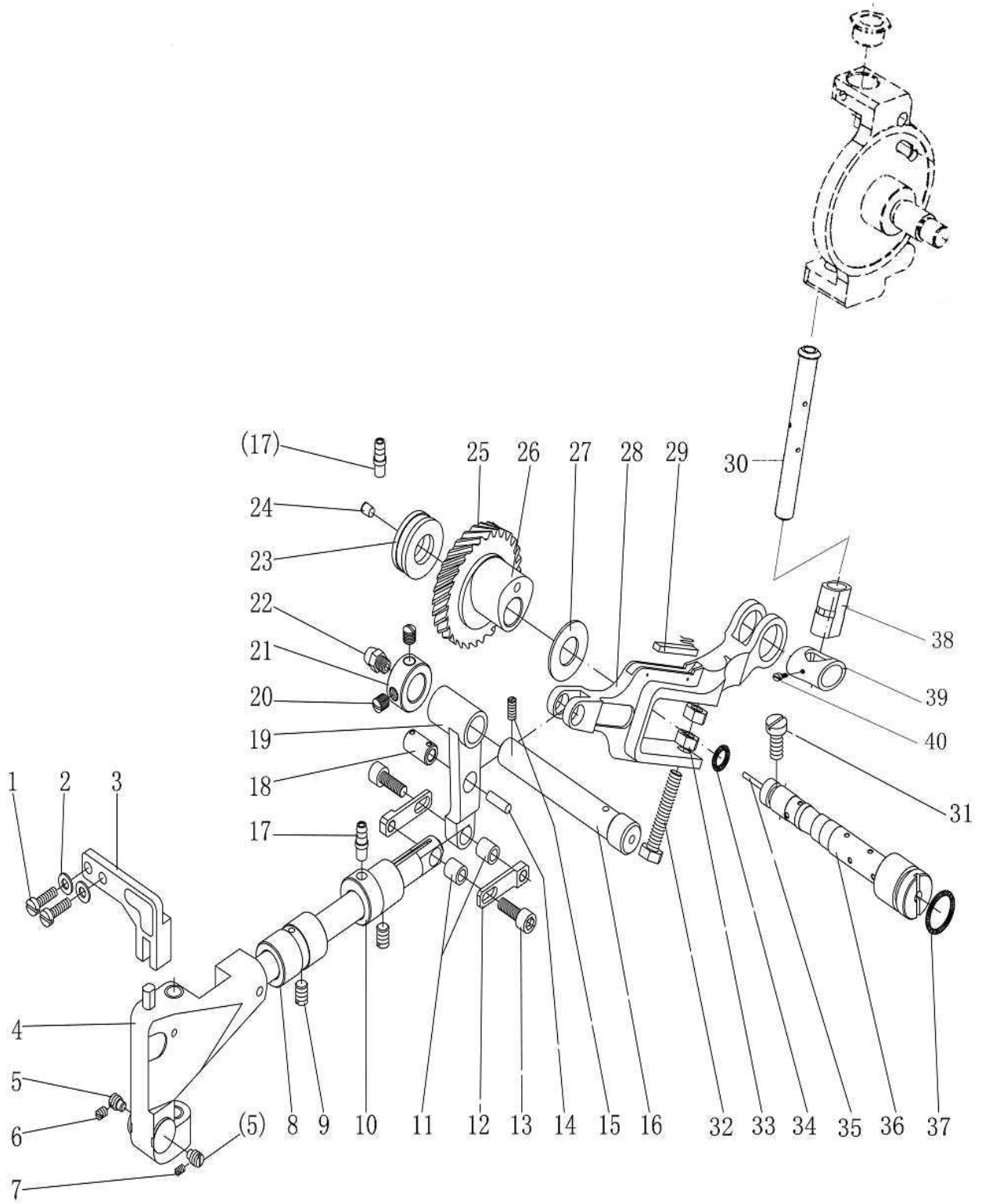

D. Needle bar vibrating parts (一)

No.	Part No.	Name	Qty	
			ZZ-2568 AUT	ZZ-2567 AUT
D01	7.02.15.405	Fixed bracket screw	5	5
D02	7.02.18.071	Washer	2	2
D03	7.02.13.043	Needle bar vibrating fixed bracket	1	1
D04	7.02.01.039	Needle bar vibrating bracket	1	1
D05	7.02.15.407	Needle bar vibrating bracket screw	2	2
D06	7.02.15.391	Tighten screw	1	1
D07	7.02.15.406	Tighten screw	1	1
D08	7.02.08.096	Needle bar vibrating shaft bushing (left)	1	1
D09	7.02.15.410	Needle bar vibrating shaft bushing screw	2	2
D10	7.02.08.097	Needle bar vibrating shaft bushing (right)	1	1
D11	7.02.08.101	Connection bushing	2	2
D12	7.02.17.091	Connection plate	2	2
D13	7.02.15.443	Connection screw	2	2
D14		Felt	1	1
D15	7.02.15.049	Needle feeding crank shaft tighten screw	1	1
D16	7.02.03.075	Needle feeding crank shaft	1	1
D17	7.02.16.059	Oil spile	2	2
D18	7.02.10.093	Connection shaft	1	1
D19	7.02.05.076	Link lever	1	1
D20	7.02.15.428	Collar screw	2	2
D21	7.02.09.030	Needle feeding crank shaft collar	1	1
D22	7.02.16.067	Coppery oil spile	1	1
D23	7.02.04.026	Bearing	1	
D24	7.02.16.064	Aluminium oil plug	1	
D25	7.02.07.050	Vibrating needle driven gear	1	
D26	7.02.06.092	Vibrating needle cam(ZZ-2565/2565 AUT)		
	7.02.06.037	Vibrating needle cam	1	
D27	7.02.18.075	Coppery washer	1	
D28	7.02.05.077	Vibrating needle link lever	1	
D29	7.02.16.056	Felt	1	
D30	7.02.03.491	Vibrating range shaft	1	
D31	7.02.15.426	Vibrating needle eccentric shaft screw	1	
D32	7.02.15.446	Vibrating needle link rod screw	1	
D33	7.02.15.449	Vibrating needle link rod screw locking nut	2	
D34	7.02.16.065	Vibrating needle eccentric shaft O-ring (small)	1	
D35		Oil wick	1	
D36	7.02.10.094	Vibrating needle eccentric shaft	1	
D37	7.02.16.066	O-ring (big)	1	
D38	7.02.08.099	Vibrating bushing	1	
D39	7.02.08.100	Connection bushing	1	
D40	7.02.15.427	Connection bushing screw	1	

E. Needle bar vibrating parts (二)

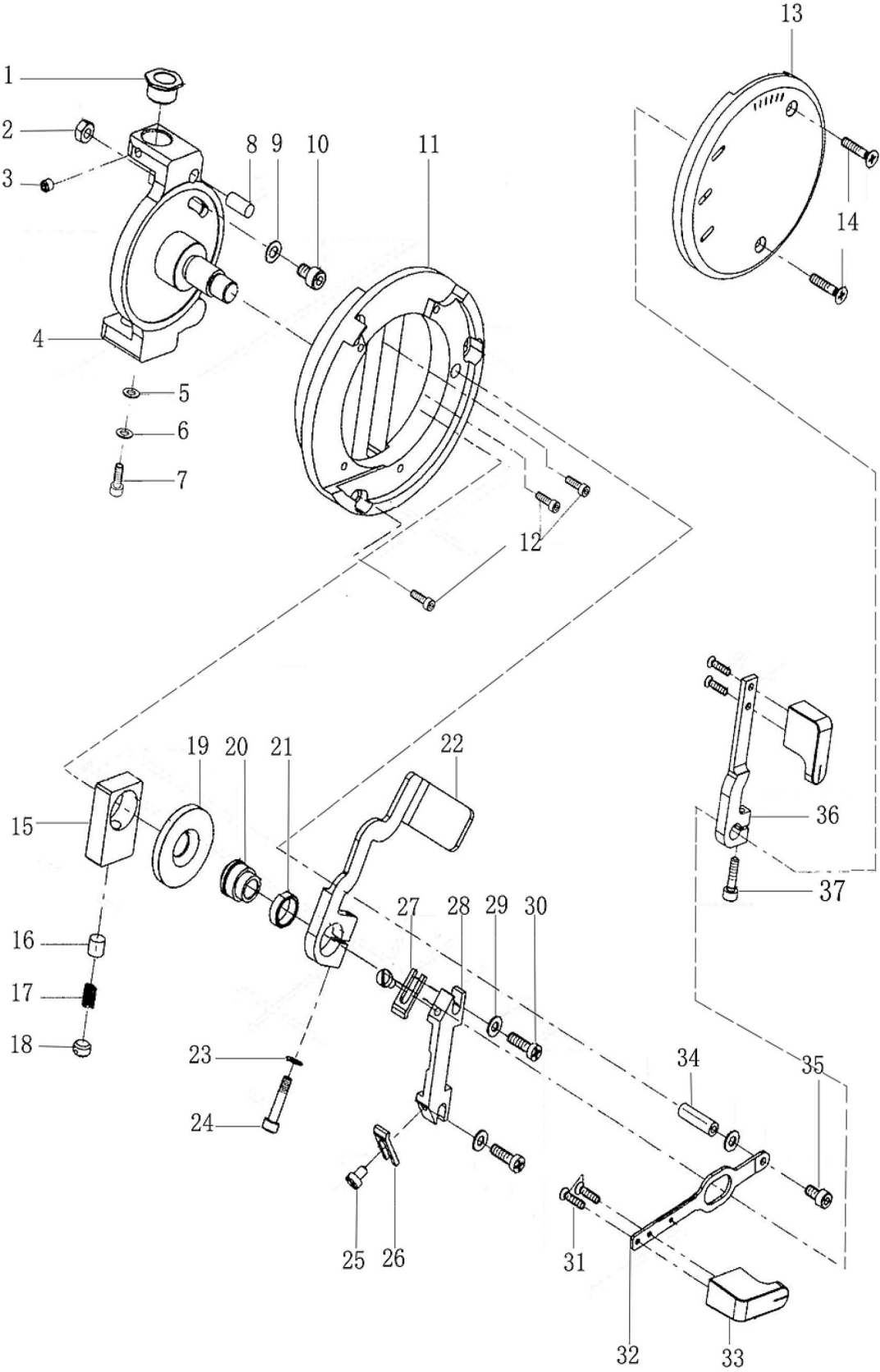

E. Needle bar vibrating parts (二)

No.	Part No.	Name	Qty	
			ZZ-2568 AUT	ZZ-2567 AUT
E01	7.02.08.367	Eccentric bushing	1	
E02	7.02.15.268	Nut	1	
E03	7.02.15.047	Screw	1	
E04	7.02.13.440	Vibrating bracket	1	
E05	7.02.18.016	Washer	1	
E06	7.02.18.055	Elastic washer	1	
E07	7.02.15.008	Screw	1	
E08	7.02.10.303	Retainer ring	1	
E09	7.02.18.057	Washer	1	
E10	7.02.15.1031	Screw	1	
E11	7.02.06.084	Turntable	1	
E12	7.02.15.405	Turntable mounting screw	3	
E13	7.02.16.503	Scale	1	
	7.02.16.105	Scale(ZZ-2565/2565 AUT)	1	
E14	7.02.15.1088	Screw	2	
E15	7.02.12.082	Slide block	1	
E16	7.02.16.509	Adjusting plug	1	
E17	7.02.17.480	Spring	1	
E18	7.02.15.423	Adjusting screw	1	
E19	7.02.18.400	Washer	1	
E20	7.02.15.1084	Nut	1	
E21	7.02.08.361	Stopper spanner handle bushing	1	
E22	7.02.05.510	Stopper spanner	1	
E23	7.02.18.057	Washer	1	
E24	7.02.15.552	Screw	1	
E25	7.02.15.1031	Screw	2	
E26	7.02.11.591	Clamp plate (left)	1	
E27	7.02.11.591	Clamp plate (right)	1	
E28	7.02.11.593	Stopper plate	1	
E29	7.02.18.071	Washer	3	
E30	7.02.15.1074	Screw	2	
E31	7.02.15.421	Screw	4	
E32	7.02.05.511	Vibrating needle spanner	1	
E33	7.02.16.504	Handle	2	
E34	7.02.15.1082	Nut	1	
E35	7.02.15.837	Screw	1	
E36	7.02.05.512	Changing-over spanner	1	
E37	7.02.15.1074	Screw	1	

F. Presser foot parts

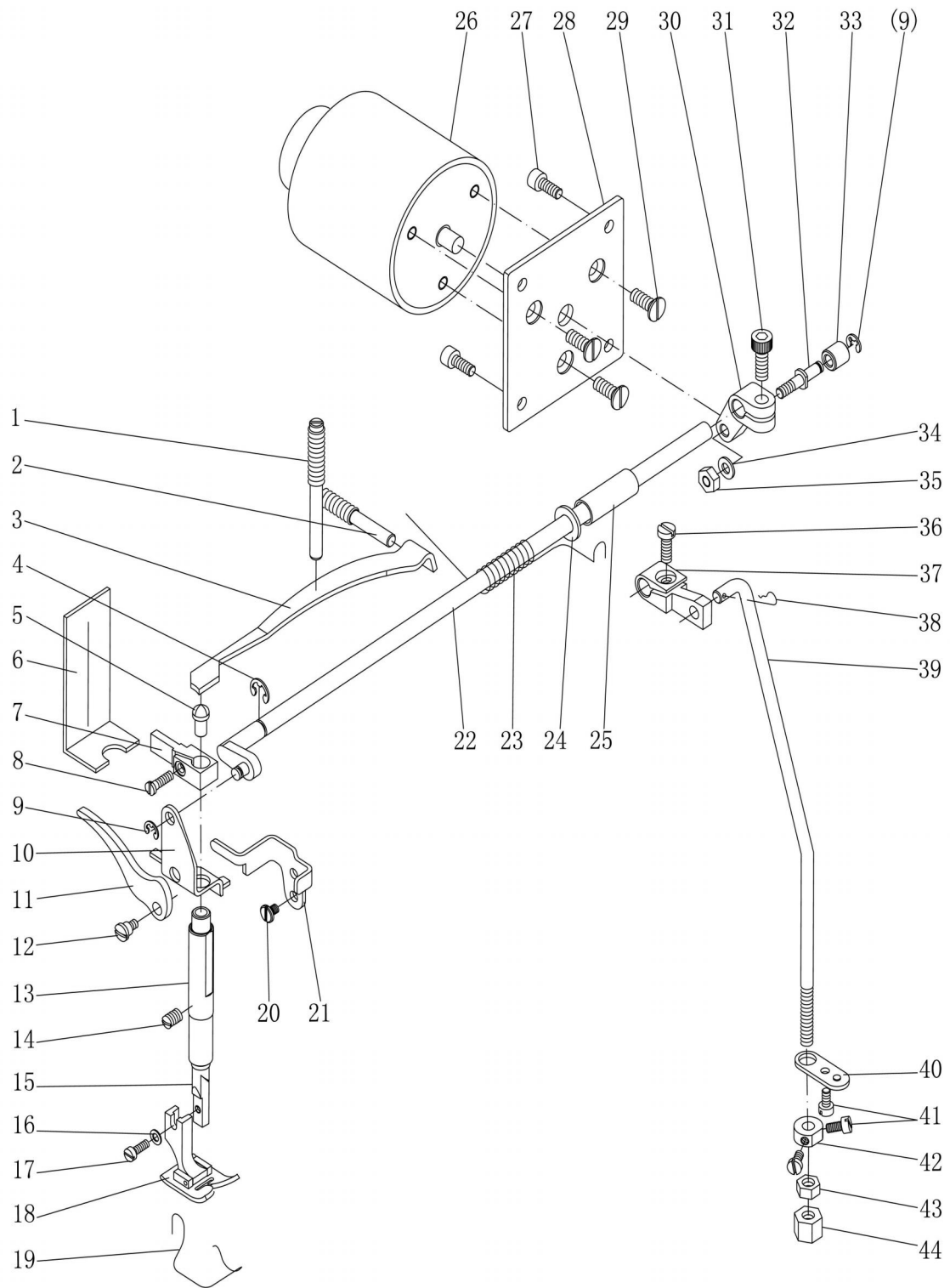

F. Presser foot parts

No.	Part No.	Name	Qty	
			ZZ-2568 AUT	ZZ-2567 AUT
F01	7.02.15.414	Presser foot pressure adjustive screw	1	1
F02	7.02.15.415	Presser bar spring support screw	1	1
F03	7.02.17.085	Presser bar spring	1	1
F04	7.02.18.072	E-ring	1	1
F05	7.02.10.092	Presser bar pin	1	1
F06	7.02.16.033	Felt	1	1
F07	7.02.12.045	Presser bar slide block	1	1
F08	7.02.15.417	Presser bar slide block screw	1	1
F09	7.02.18.031	E-ring	2	2
F10	7.02.17.087	Presser foot lifting connection plate	1	1
F11	7.02.05.068	Presser bar spanner	1	1
F12	7.02.15.418	Presser bar spanner screw	1	1
F13	7.02.08.098	Presser bar bushing	1	1
F14	7.02.15.411	Presser bar bushing tighten screw	1	1
F15	7.02.03.072	Presser bar	1	1
F16	7.02.18.057	Presser bar screw washer	1	1
F17	7.02.15.419	Presser bar screw	1	1
F18	7.02.02.089	Presser foot	1	1
	7.02.02.080	Presser foot(ZZ-2565/2565 AUT)		
F19	7.02.17.088	Spring	1	1
F20	7.02.15.394	Release lever screw	1	1
F21	7.02.05.063	Release lever	1	1
F22	7.02.03.073	Presser foot lifting shaft	1	1
F23	7.02.17.086	Replacement spring	1	1
F24	7.02.18.060	Washer	1	1
F25	7.02.08.040	Presser foot lifting shaft bushing	1	1
F26	7.02.19.041	Presser foot lifting electromagnetic	1	1
F27	7.02.15.1085	Fixed plate screw	4	4
F28	7.02.11.095	Presser foot lifting electromagnetic fixed plate	1	1
F29	7.02.15.105	Presser foot lifting electromagnetic screw	3	3
F30	7.02.06.081	Presser foot lifting crank	1	1
F31	7.02.15.048	Presser foot lifting crank screw	1	1
F32	7.02.10.146	Presser foot lifting crank pin	1	1
F33	7.02.12.081	Slide pole	1	1
F34	7.02.18.016	Washer	1	1
F35	7.02.15.068	Presser foot lifting crank pin nut	1	1
F36	7.02.15.416	Knee lifting crank screw	1	1
F37	7.02.05.069	Knee lifting crank	1	1
F38	7.02.17.041	Pin	1	1
F39	7.02.01.04001	Presser foot lifting link lever	1	1
F40	7.02.01.04002	Link lever fixed plate	1	1
F41	7.02.15.420	Link lever fixed plate screw	3	3
F42	7.02.01.04003	Link lever collar	1	1
F43	7.02.01.04004	Nut	1	1
F44	7.02.01.04005	Knee lifting connection nut	1	1

G. Stitch length adjustment and backstitch parts

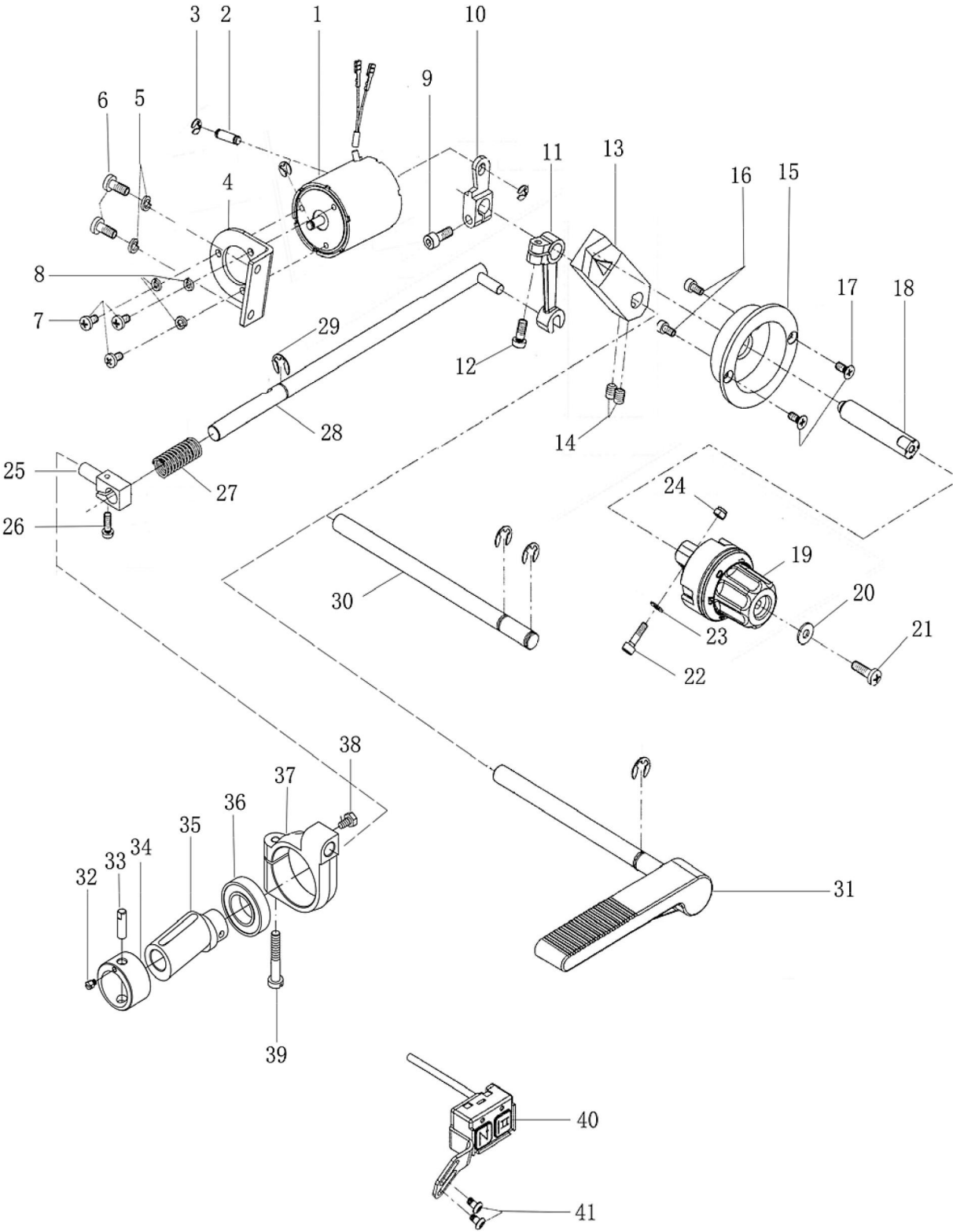

G. Stitch length adjustment and backstitch parts

No.	Part No.	Name	Qty	
			ZZ-2568 AUT	ZZ-2567 AUT
G01	7.02.19.040	Backstitch electromagnetic	1	1
G02	7.02.10.304	Backstitch electromagnetic connecting pin	1	1
G03	7.02.18.031	E-ring	3	3
G04	7.02.13.443	Backstitch electromagnetic mounting plate	1	1
G05	7.02.18.055	Spring washer	2	2
G06	7.02.15.1085	Screw	2	2
G07	7.02.15.1080	Screw	3	3
G08	7.02.18.098	Spring washer	3	3
G09	7.02.15.058	Screw	1	1
G10	7.02.06.085	Backstitch electromagnetic crank	1	1
G11	7.02.05.080	Backstitch control lever crank	1	1
G12	7.02.15.416	Crank screw	2	2
G13	7.02.05.513	Stitch length vibrating lever	1	1
G14	7.02.15.057	Screw	2	2
G15	7.02.13.441	Stitch length holder	1	1
G16	7.02.15.063	Screw	2	2
G17	7.02.15.1087	Screw	2	2
G18	7.02.03.492	Stitch length shaft	1	1
G19	7.02.01.212	Stitch length adjustment assy.	1	1
G20	7.02.18.058	Washer	1	1
G21	7.02.15.1086	Screw	1	1
G22	7.02.15.1034	Screw	1	1
G23	7.02.18.042	Washer	1	1
G24	7.02.15.574	Nut	1	1
G25	7.02.12.050	Backstitch block	1	1
G26	7.02.15.424	Backstitch block screw	1	1
G27	7.02.17.092	Replacement spring	1	1
G28	7.02.03.076	Backstitch connection shaft	1	1
G29	7.02.18.028	E-ring	3	3
G30	7.02.03.493	Backstitch shaft	1	1
G31	7.02.03.077	Backstitch shaft assy(ZZ-2568/ZZ-2567)		
G32	7.02.01.04204	Orientation pin screw	1	1
G33	7.02.01.04203	Orientation pin	1	1
G34	7.02.01.04202	Feed backstitch cam bushing	1	1
G35	7.02.01.04201	Feed backstitch cam	1	1
G36	7.02.04.024	Backstitch cam crank bearing	1	1
G37	7.02.06.039	Backstitch cam crank	1	1
G38	7.02.15.447	Backstitch block tighten screw	1	1
G39	7.02.15.436	Backstitch cam crank screw	1	1
G40	7.02.19.037	Switch	1	1
G41	7.02.15.1080	Screw	2	2
G42	7.02.07.197	Gear	2	2

H. Lower shaft, feed dog and presser foot lifting parts

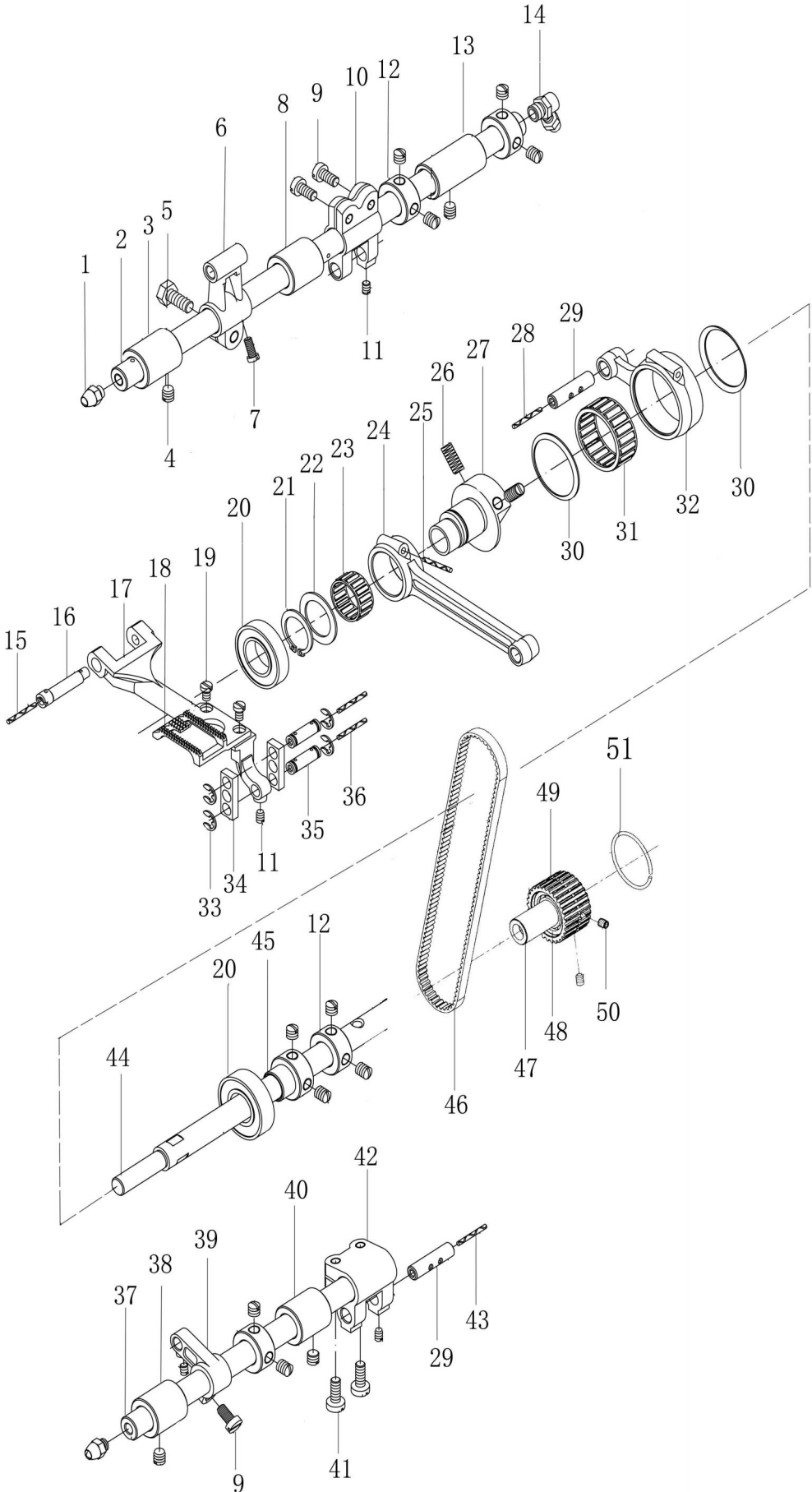

H. Lower shaft, feed dog and presser foot lifting parts

No.	Part No.	Name	Qty	
			ZZ-2568 AUT	ZZ-2567 AUT
H01	7.02.16.067	Oil spile	2	2
H02	7.02.03.079	Feed shaft	1	1
H03	7.02.08.103	Feed shaft bushing (left)	1	1
H04	7.02.15.428	Bushing screw	14	14
H05	7.02.15.448	Feed crank (left) screw	1	1
H06	7.02.05.081	Feed crank (left)	1	1
H07	7.02.15.408	Feed dog holder adjustive pin screw	1	1
H08	7.02.08.104	Feed shaft bushing (middle)	1	1
H09	7.02.15.430	Feed crank (right) screw	3	3
H10	7.02.06.038	Feed crank (right)	1	1
H11	7.02.15.391	Feed crank pin screw	4	4
H12	7.02.09.030	Collar	3	4
H13	7.02.08.105	Feed shaft bushing (right)	1	1
H14	7.02.16.072	Oil spile (big)	1	1
H15		Feed dog holder adjustive pin oil wick	2	2
H16	7.02.10.097	Feed dog holder adjustive pin	1	1
H17	7.02.02.090	Feed dog holder	1	1
H18	7.02.02.087	Feed dog	1	1
	7.02.02.081	Feed dog(ZZ-2565/2565 AUT)		
	7.02.02.629	Feed dog for thin material (new version)		
H19	7.02.15.433	Feed dog screw	2	2
H20	7.02.04.015	Lifting feed dog cam bearing	2	2
H21	7.02.18.079	Elastic stop ring	1	1
H22	7.02.18.080	Washer	1	1
H23	7.02.04.030	Lifting feed dog cam link lever bearing	1	1
H24	7.02.05.082	Lifting feed dog cam link lever	1	1
H25		Lifting feed dog cam link lever oil wick	1	1
H26	7.02.15.050	Lifting feed dog cam screw	2	2
H27	7.02.07.055	Lifting feed dog cam	1	1
H28		Backstitch cam link lever oil wick	1	1
H29	7.02.10.096	Feed crank pin	2	2
H30	7.02.18.082	Bearing washer	2	2
H31	7.02.04.029	Backstitch cam link lever bearing	1	1
H32	7.02.05.083	Backstitch cam link lever	1	1
H33	7.02.18.039	E-ring	4	4
H34	7.02.11.065	Connection plate	2	2
H35	7.02.10.095	Lifting feed dog cam link lever pin	2	2
H36		Lifting feed dog cam link lever pin oil wick	1	1
H37	7.02.03.080	Lifting feed dog shaft	1	1
H38	7.02.08.108	Lifting feed dog shaft bushing (left)	1	1
H39	7.02.05.084	Lifting feed dog crank (left)	1	1
H40	7.02.08.109	Lifting feed dog shaft bushing (right)	1	1
H41	7.02.15.389	Lifting feed dog crank (right) screw	2	2
H42	7.02.06.040	Lifting feed dog crank (right)	1	1
H43		Lifting feed dog crank pin oil wick	1	1
H44	7.02.03.494	Lower shaft	1	1
H45	7.02.08.107	Lower shaft bearing bushing	1	1
H46	7.02.07.198	Synchronous belt	1	1
H47	7.02.08.366	Bearing connection bushing	1	1
H48	7.02.04.024	Lower shaft bearing	1	1
H49	7.02.07.196	Synchronous pulley (lower)	1	1
H50	7.02.15.052	Synchronous pulley screw	2	2
H51	7.02.09.036	Synchronous pulley isolating ring	1	1

I. Hook assembly

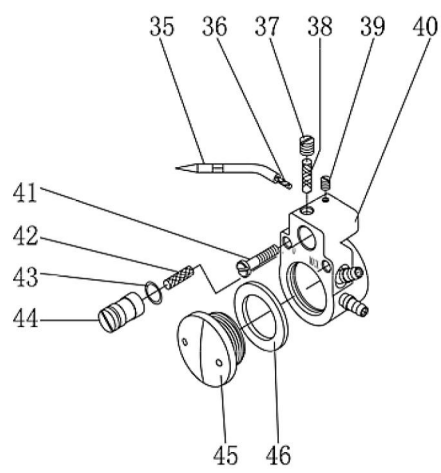
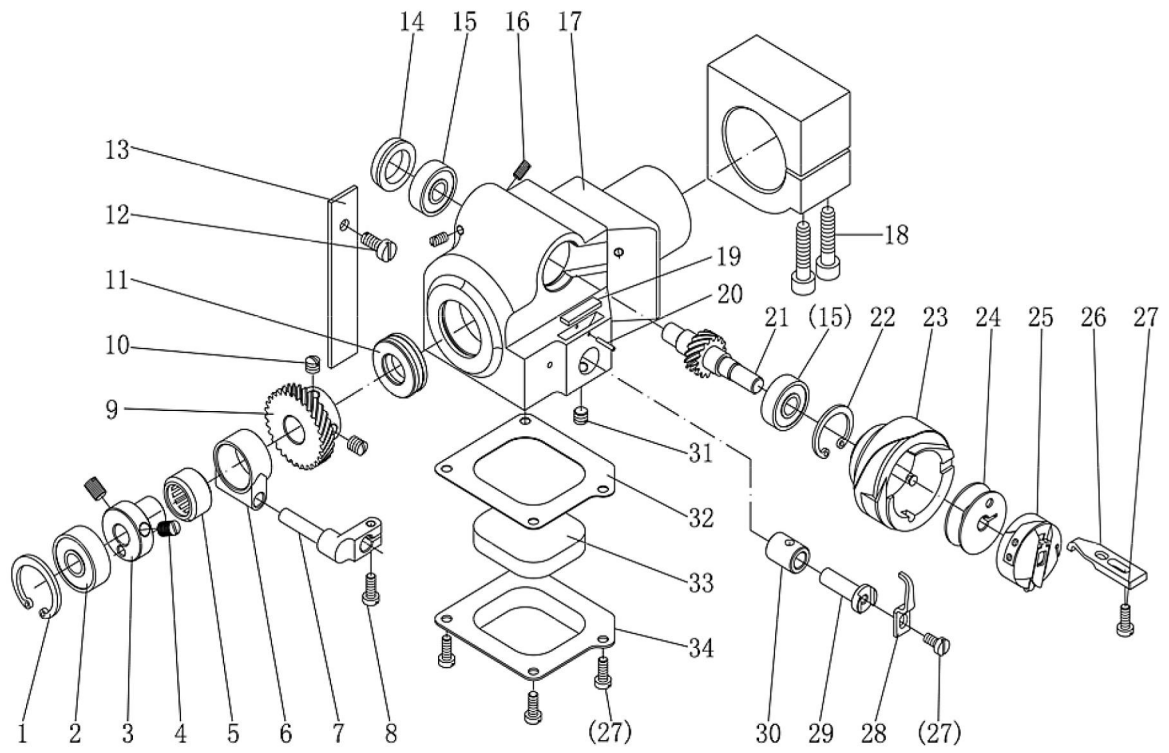

I. Hook assembly

No.	Part No.	Name	Qty	
			ZZ-2568 AUT	ZZ-2567 AUT
I01	7.02.18.026	Elastic stop ring	1	1
I02	7.02.04.031	Bearing	1	1
I03	7.02.06.041	Opener cam	1	1
I04	7.02.15.434	Opener cam screw	2	2
I05	7.02.04.033	Opener cam bearing	1	1
I06	7.02.08.112	Opener cam bushing	1	1
I07	7.02.08.111	Hook opener	1	1
I08	7.02.15.017	Hook opener screw	1	1
I09	7.02.07.058	Hook drive gear	1	1
I10	7.02.15.126	Drive gear screw	2	2
I11	7.02.04.026	Bearing	1	1
I12	7.02.15.439	Felt fixed screw	1	1
I13	7.02.16.051	Felt	1	1
I14	7.02.09.031	Hook saddle bearing cover	1	1
I15	7.02.04.016	Bearing	2	2
I16	7.02.15.438	Bearing cover screw	2	2
I17	7.02.13.046	Hook saddle	1	1
I18	7.02.15.445	Hook saddle fixed screw	2	2
I19		Felt	1	1
I20	7.02.10.098	Elastic pin	1	1
I21	7.02.07.057	Hook gear	1	1
I22	7.02.18.027	Elastic stop ring	1	1
I23	7.02.02.093	Hook	1	1
I24	7.02.21.144	Bobbin	1	1
I25	7.02.02.095	Bobbin case	1	1
I26	7.02.02.094	Hook orientation claw	1	1
I27	7.02.15.006	Hook orientation claw screw	5	5
I28	7.02.02.091	Hook thread distributing claw	1	1
I29	7.02.10.099	Hook thread distributing bracket	1	1
I30	7.02.08.110	Hook thread distributing bracket bushing	1	1
I31	7.02.15.440	Bushing tighten screw	1	1
I32	7.02.18.084	Hook saddle bottom cover washer	1	1
I33	7.02.16.094	Felt	1	1
I34	7.02.13.047	Hook saddle bottom cover	1	1
I35	7.02.16.075	Hook coppery oil tube	1	1
I36		Hook oil wick	1	1
I37	7.02.15.441	Oil seal screw	1	1
I38		Oil box felt	1	1
I39	7.02.15.406	Coppery oil tube tighten screw	1	1
I40	7.02.13.048	Hook saddle oil box	1	1
I41	7.02.15.442	Oil box screw	1	1
I42	7.02.16.451	Oil quantity adjustive valve felt	1	1
I43		Oil quantity adjustive valve O-ring	1	1
I44		Oil quantity adjustive valve	1	1
I45	7.02.16.069	Oil window cover	1	1
I46	7.02.16.071	Oil window cover washer	1	1

J. Hook assembly (Small hook)

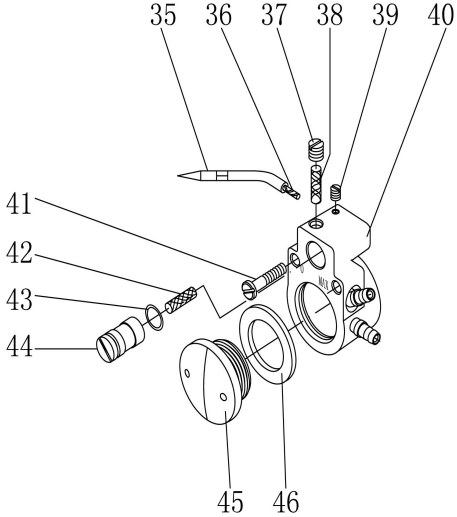
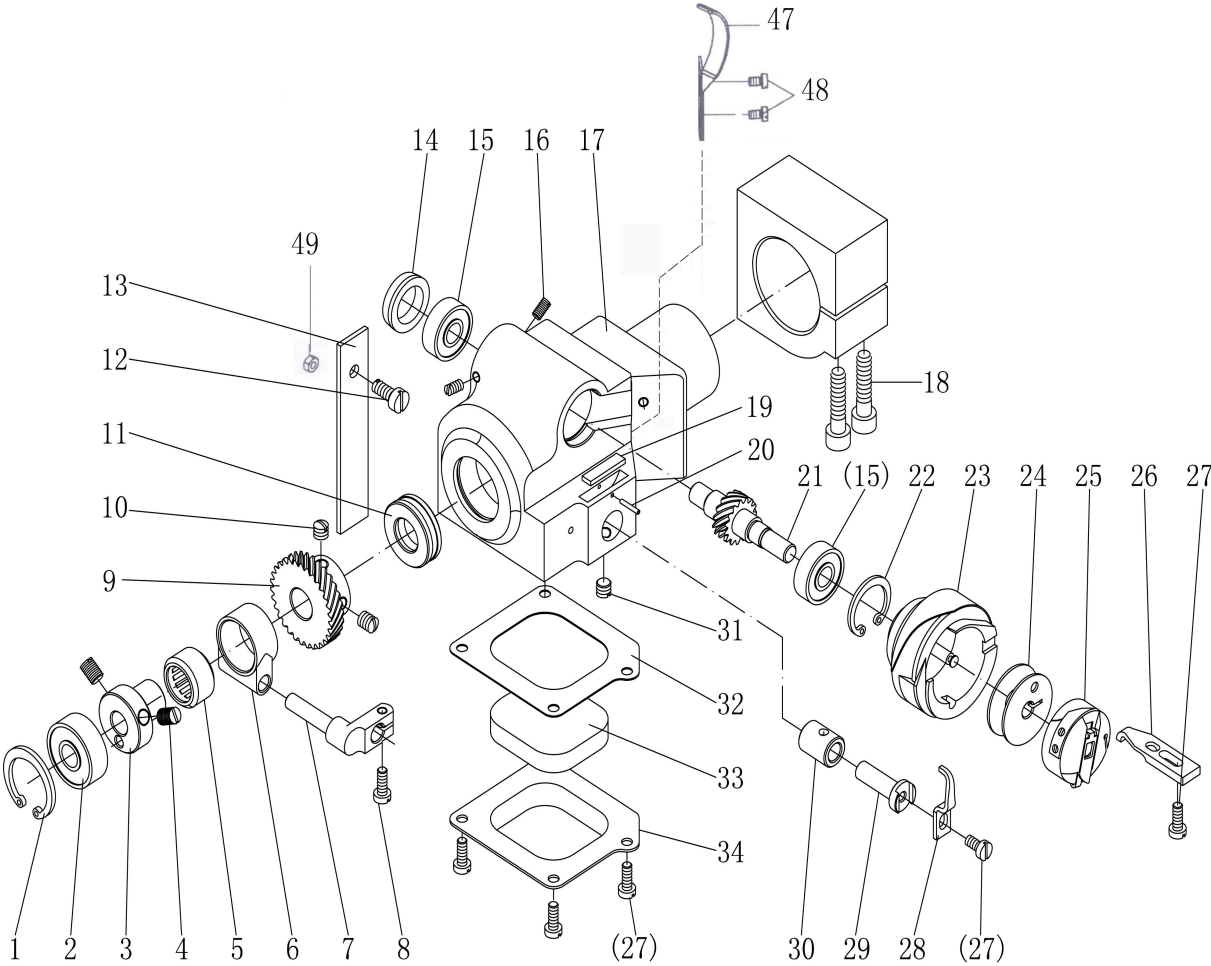

J. Hook assembly (Small hook)

No.	Part No.	Name	Qty		
			ZZ-2565 AUT	ZZ-2568 AUT	ZZ-2567 AUT
J01	7.02.18.026	Elastic stop ring	1		
J02	7.02.04.031	Bearing	1		
J03	7.02.06.093	Opener cam	1		
J04	7.02.15.434	Opener cam screw	2		
J05	7.02.04.033	Opener cam bearing	1		
J06	7.02.08.112	Opener cam bushing	1		
J07	7.02.08.111	Hook opener	1		
J08	7.02.15.017	Hook opener screw	1		
J09	7.02.07.072	Hook drive gear	1		
J10	7.02.15.126	Drive gear screw	2		
J11	7.02.04.026	Bearing	1		
J12	7.02.15.439	Felt fixed screw	1		
J13	7.02.16.051	Felt	1		
J14	7.02.09.037	Hook saddle bearing cover	1		
J15	7.02.04.135	Bearing	2		
J16	7.02.15.438	Bearing cover screw	2		
J17	7.02.13.077	Hook saddle	1		
J18	7.02.15.445	Hook saddle fixed screw	2		
J19		Felt	1		
J20	7.02.10.098	Elastic pin	1		
J21	7.02.07.073	Hook gear	1		
J22	7.02.18.167	Elastic stop ring	1		
J23	7.02.02.111	Hook	1		
J24	7.02.21.239	Bobbin	1		
J25	7.02.02.112	Bobbin case	1		
J26	7.02.02.113	Hook orientation claw	1		
J27	7.02.15.006	Hook orientation claw screw	5		
J28	7.02.02.114	Hook thread distributing claw	1		
J29	7.02.10.099	Hook thread distributing bracket	1		
J30	7.02.08.110	Hook thread distributing bracket bushing	1		
J31	7.02.15.440	Bushing tighten screw	1		
J32	7.02.18.084	Hook saddle bottom cover washer	1		
J33	7.02.16.094	Felt	1		
J34	7.02.13.047	Hook saddle bottom cover	1		
J35	7.02.16.075	Hook coppery oil tube	1		
J36		Hook oil wick	1		
J37	7.02.15.441	Oil seal screw	1		
J38		Oil box felt	1		
J39	7.02.15.406	Coppery oil tube tighten screw	1		
J40	7.02.13.048	Hook saddle oil box	1		
J41	7.02.15.442	Oil box screw	1		
J42	7.02.16.451	Oil quantity adjustive valve felt	1		
J43		Oil quantity adjustive valve O-ring	1		
J44		Oil quantity adjustive valve	1		
J45	7.02.16.069	Oil window cover	1		
J46	7.02.16.071	Oil window cover washer	1		
J47	7.02.11.106	Guard plate	1		
J48		Screw	2		
J49		Nut	1		

L. Thread trimming parts

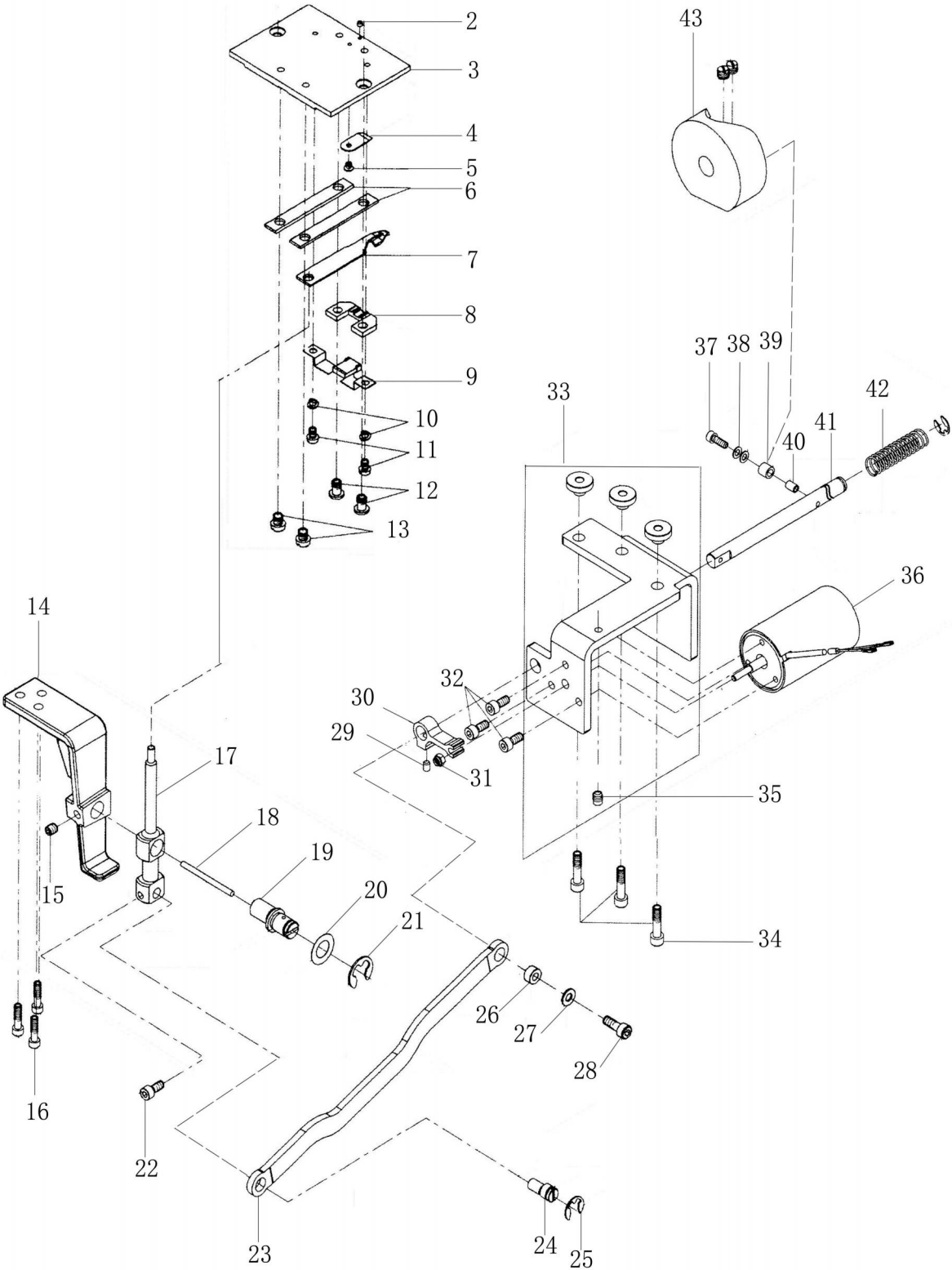

L.Thread trimming parts

No.	Part No.	Name	Qty	
			ZZ-2568 AUT	ZZ-2567 AUT
L02	7.02.15.104	Screw	1	1
L03	7.02.02.073	Slide plate	1	1
L04	7.02.20.031	Fixed knife	1	1
L05	7.02.15.103	Fixed knife screw	1	1
L06	7.02.11.102	Movable knife guide plate	2	2
L07	7.02.20.030	Movable knife	1	1
L08	7.02.11.103	Movable knife support plate	1	1
L09	7.02.11.098	Movable knife assistant support plate	1	1
L10	7.02.18.061	Spring washer	2	2
L11	7.02.15.101	Movable knife assistant support plate screw	2	2
L12	7.02.15.102	Movable knife support plate screw	2	2
L13	7.02.15.100	Movable knife guide plate screw	2	2
L14	7.02.13.074	Thread trimming vibrating lever socket	1	1
L15	7.02.15.056	Thread trimming vibrating lever pin screw	1	1
L16	7.02.15.053	Thread trimming vibrating lever socket mounting screw	3	3
L17	7.02.05.515	Thread trimming vibrating lever	1	1
L18		Oil wick	1	1
L19	7.02.10.305	Pin	1	1
L20	7.02.18.402	Washer	1	1
L21	7.02.21.085	E-ring	1	1
L22	7.02.15.555	Screw	1	1
L23	7.02.05.514	Thread trimming link lever	1	1
L24	7.02.10.306	Eccentric pin	1	1
L25	7.02.18.021	E-ring	2	2
L26	7.02.08.365	Thread trimming link lever bushing	1	1
L27	7.02.18.071	Washer	1	1
L28	7.02.15.577	Screw	1	1
L29	7.02.15.596	Screw	3	3
L30	7.02.12.083	Stopper block	1	1
L31		Thread trimming electromagnetic nut	1	1
L32	7.02.15.803	Screw	3	3
L33	7.02.13.442	Thread trimming setting bracket	1	1
L34	7.02.15.058	Thread trimming setting bracket screw	3	3
L35	7.02.15.052	Screw	1	1
L36	7.02.19.038	Thread trimming electromagnetic	1	1
L37	7.02.15.1034	Screw	1	1
L38	7.02.18.403	Washer	2	2
L39	7.02.08.363	Thread trimming bushing 2	1	1
L40	7.02.08.364	Thread trimming bushing 1	1	1
L41	7.02.03.495	Thread trimming shaft	1	1
L42	7.02.17.092	Spring	1	1
L43	7.02.06.086	Thread trimming cam	1	1

M. Tension release, electrocircuit board, oil circuit parts

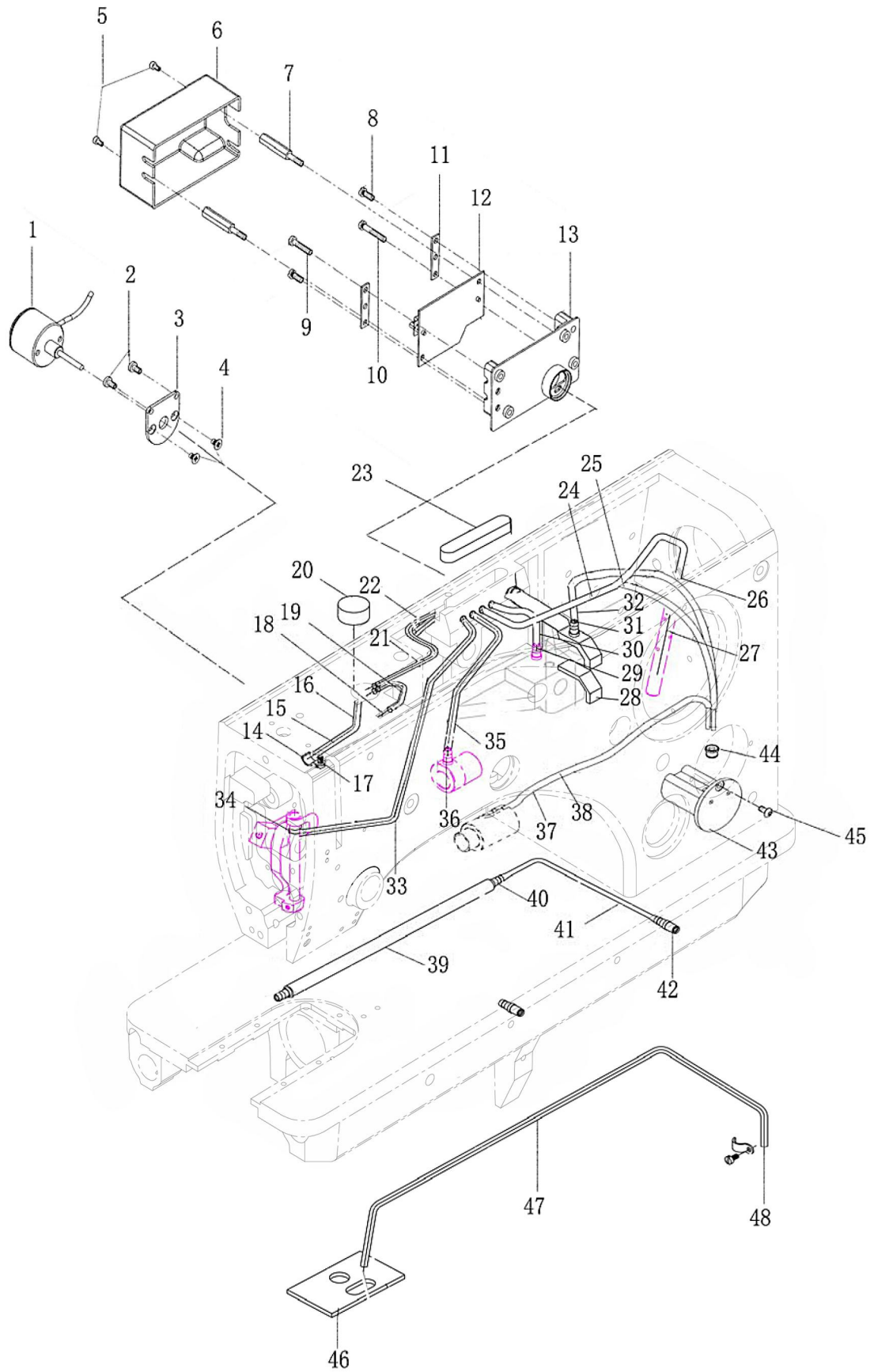

M. Tension release, electrocircuit board, oil circuit parts

No.	Part No.	Name	Qty	
			ZZ-2568 AUT	ZZ-2567 AUT
M01	7.02.19.039	Thread releasing solenoid	1	1
M02	7.02.15.1080	Screw	2	2
M03	7.02.11.594	Mounting plate	1	1
M04	7.02.15.797	Screw	2	2
M05	7.02.15.432	Screw	2	2
M06	7.02.16.505	Collection circuit board housing	1	1
M07	7.02.15.1083	Support screw	2	2
M08	7.02.15.017	Pressure plate screw	2	2
M09	7.02.15.1162	Pressure plate screw	1	1
M10	7.02.15.442	Pressure plate screw	1	1
M11	7.02.11.595	Thread tension plate	2	2
M12	7.02.11.596	Circuit board	1	1
M13	7.02.16.506	Circuit collection plate	1	1
M14	7.02.17.029	Oil tube clip	2	2
M15		Oil wick	1	1
M16		Oil tube	1	1
M17	7.02.15.037	Oil tube clip screw	2	2
M18		Oil wick	1	1
M19		Oil tube	1	1
M20	7.02.16.032	Felt	2	2
M21		Oil wick	1	1
M22		Oil tube	1	1
M23	7.02.16.034	Felt	1	1
M24		Oil wick	1	1
M25		Oil tube	1	1
M26		Oil tube	1	1
M27		Oil wick	1	1
M28	7.02.16.092	Felt	1	1
M29		Oil wick	1	1
M30		Oil tube	1	1
M31		Oil wick	1	1
M32		Oil tube	1	1
M33		Oil tube	1	1
M34		Oil wick	1	1
M35		Oil tube	1	1
M36		Oil wick	1	1
M37		Oil tube	1	1
M38		Oil wick	1	1
M39	7.02.16.073	Coppery oil tube	1	1
M40	7.02.16.060	Oil spile	2	2
M41		Oil tube	1	1
M42	7.02.16.059	Oil spile	2	2
M43	7.02.16.507	Oil box	1	1
M44	7.02.16.508	Oil box plug	1	1
M45	7.02.15.1080	Screw	1	1
M46	7.02.16.091	Felt	1	1
M47		Oil tube	1	1
M48		Oil wick	1	1

N. Lower direct drive parts

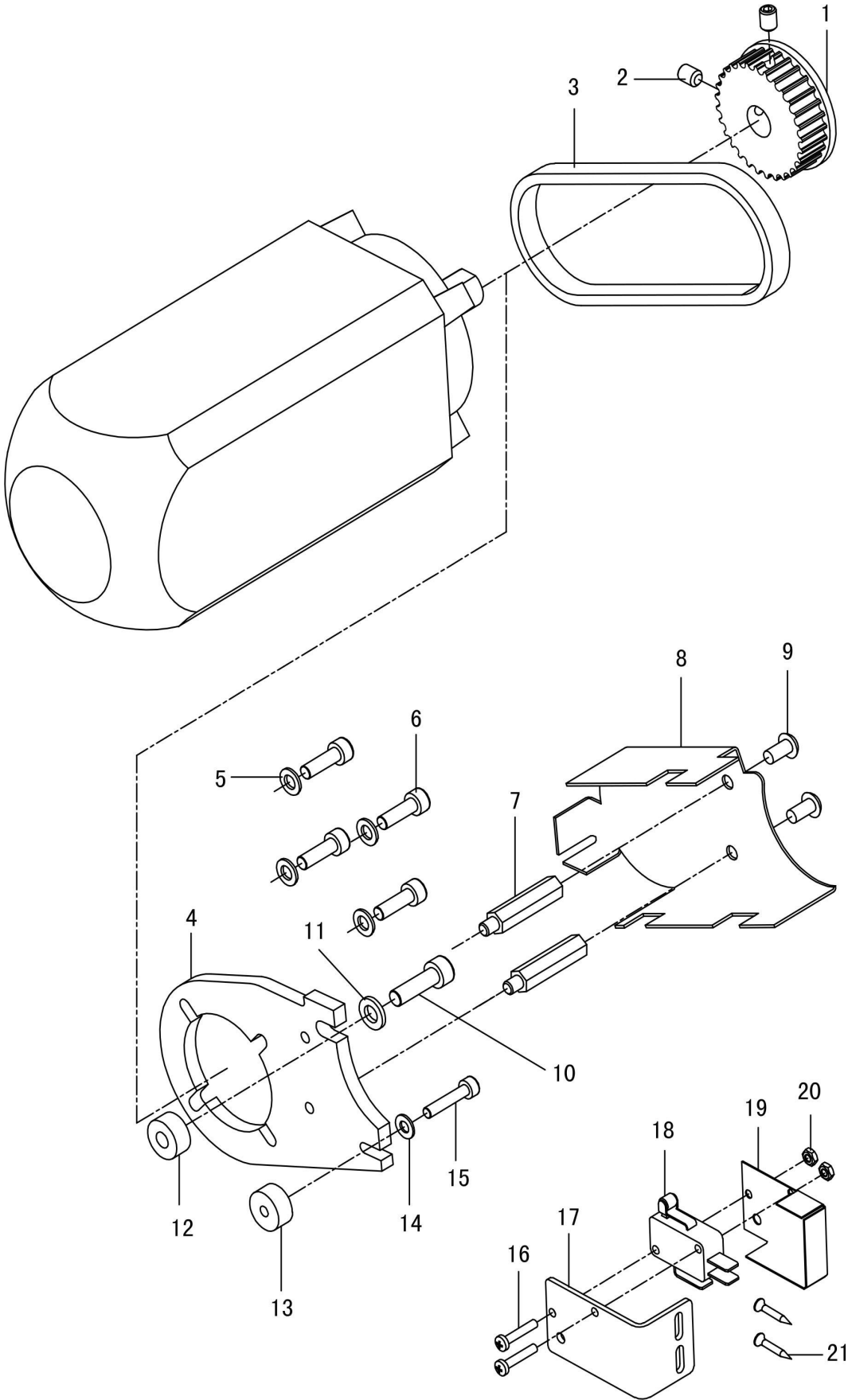

N. Lower direct drive parts

No.	Part No.	Name	Qty	
			ZZ-2568 AUT	ZZ-2567 AUT
N01	7.02.07.345	Lower direct drive timing belt wheel	1	1
N02	7.02.15.057	Timing belt wheel screw	2	2
N03	7.02.07.346	Timing belt	1	1
N04	7.02.11.615	Motor mounting plate	1	1
N05	7.02.18.016	Washer	4	4
N06	7.02.15.1051	Mounting screw (inner hexagonal round head)	4	4
N07	7.02.15.1111	Hexagonal column	2	2
N08	7.02.21.386	Belt cover	1	1
N09	7.02.15.1112	Inner hexagonal flat round head flange face screw	2	2
N10	7.02.15.312	Straight knurling inner hexagonal round head screw	1	1
N11	7.02.18.040	Washer	1	1
N12	7.02.12.196	Washer (big hole)	1	1
N13	7.02.12.195	Washer (small hole)	1	1
N14	7.02.18.042	Washer	1	1
N15	7.02.15.971	inner hexagonal round head screw	1	1
N16	7.02.15.1113	Cross slot disc head screw M3X16	2	2
N17	7.02.11.598	Switch mounting bracket	1	1
N18	7.02.19.045	Micro switch	1	1
N19	7.02.11.599	Switch cover plate	1	1
N20	7.02.15.266	Nut	2	2
N21	7.02.21.034	Switch mounting bracket wooden screw	2	2

O. Special parts for cam patterns zigzag machine

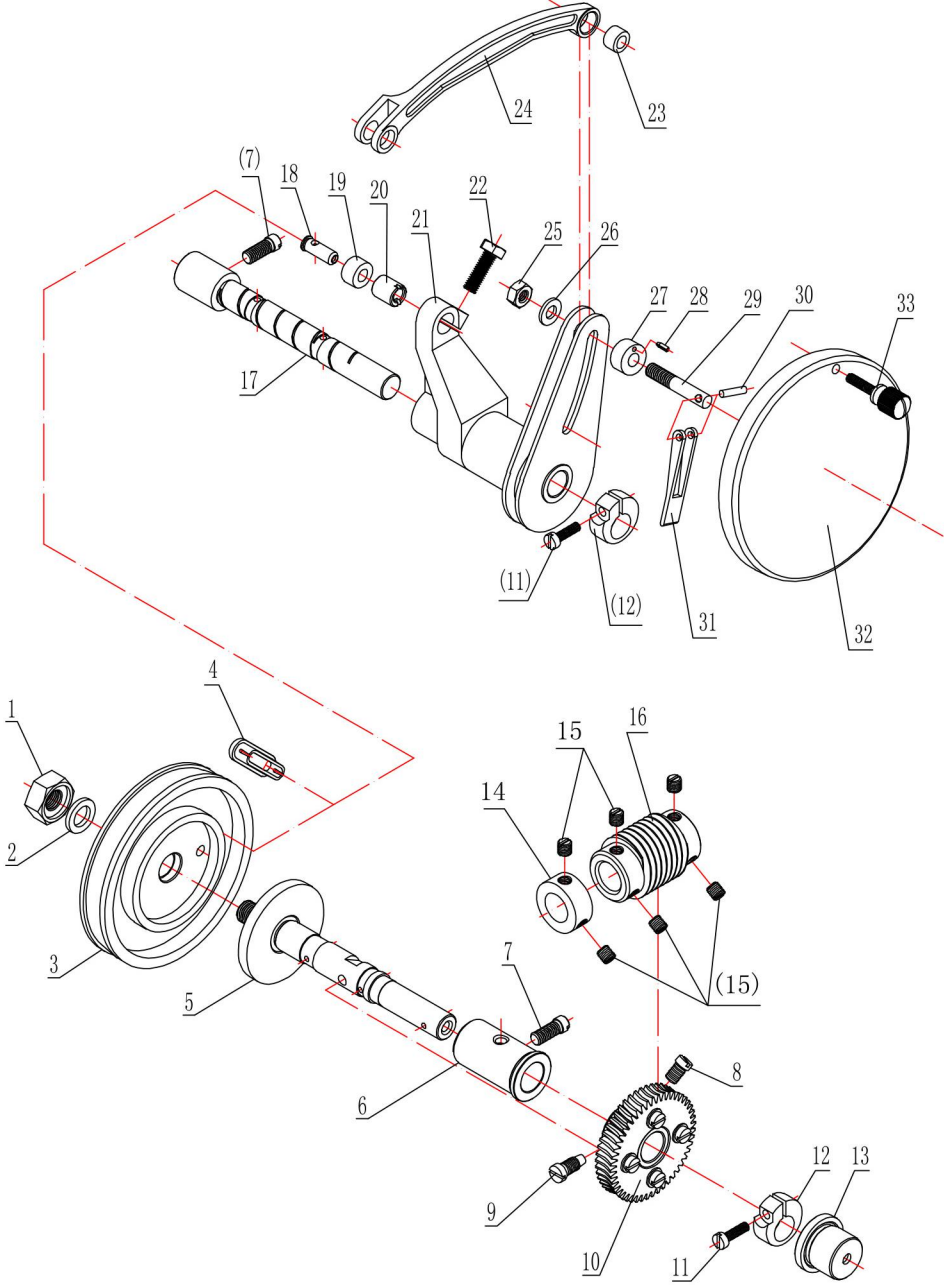

O. Special parts for cam patterns zigzag machine

No.	Part No.	Name	Qty(ZZ-2567/2567AUT)	Remark
01	7.02.15.382	Hexagonal nut	1	M10
02	7.02.17.113	Spring washer	1	
03	7.02.06.060	Cam	1	
04	7.02.16.077	Seal cover	1	
05	7.02.10.133	Worm wheel shaft	1	
06	7.02.08.094	Worm wheel shaft bushing (back)	1	
07	7.02.15.399	Screw	2	M6×14
08	7.02.15.431	Screw	1	M6(0.75)×10
09	7.02.15.384	Screw	1	M6(0.75)
10	7.02.07.069	Worm wheel	1	
11	7.02.15.405	Screw	2	M4×14
12	7.02.09.033	Retaining ring	2	
13	7.02.08.117	Worm wheel shaft bushing	1	
14	7.02.09.034	Retaining ring	1	
15	7.02.15.428	Screw	6	M6(0.75)×5
16	7.02.07.070	Worm bolt	1	
17	7.02.10.131	Vibrating needle shaft	1	
18	7.02.10.132	Roller shaft pin	1	
19	7.02.12.080	Roller pin	1	
20	7.02.08.093	Roller shaft pin eccentric bushing	1	
21	7.02.01.037	Vibrating needle crank assy.	1	
22	7.02.15.380	Screw	1	M6×18
23	7.02.08.092	Vibrating needle link bushing	1	
24	7.02.05.103	Link	1	
25	7.02.15.1073	Nut	1	M6
26	7.02.18.046	Washer	1	
27	7.02.09.038	Fixing ring	1	
28	7.02.10.130	Elastic pin	1	Φ2
29	7.02.10.308	Pin screw	1	
30	7.02.10.307	Pin	1	Φ3
31	7.02.05.516	Lever	1	
32	7.02.11.146	Cover plate	1	
33	7.02.15.1151	Screw	1	

P. Accessories

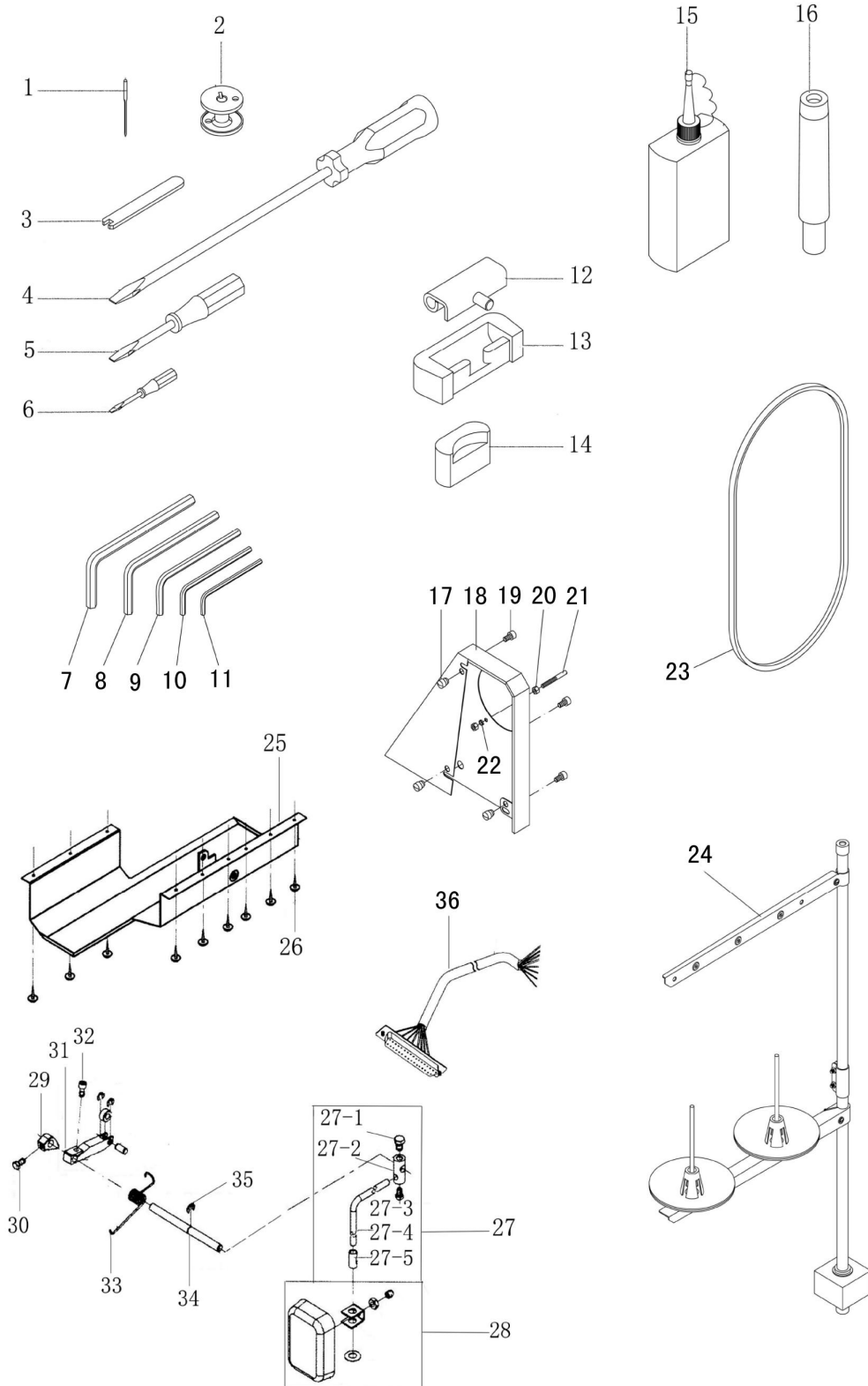

P. Accessories

No.	Part No.	Name			
			ZZ-2565 AUT	ZZ-2568 AUT	ZZ-2567 AUT
P01	7.02.21.140	Needle	4	4	4
P02	7.02.21.144	Bobbin	4	4	4
P03	7.02.21.142	Open end wrench	1	1	1
P04	7.02.21.003	Screw driver (big)	1	1	1
P05	7.02.21.002	Screw driver (middle)	1	1	1
P06	7.02.21.001	Screw driver (small)	1	1	1
P07	7.02.21.238	Hexagonal wrench M6mm	1	1	1
P08	7.02.21.143	Hexagonal wrench M5mm	1	1	1
P09	7.02.21.099	Hexagonal wrench M5mm	1	1	1
P10	7.02.21.209	Hexagonal wrench M3mm	1	1	1
P11	7.02.21.098	Hexagonal wrench M2.5mm	1	1	1
P12	7.02.21.080	Hinge	2	2	2
P13	7.02.21.079	Hinge cover	2	2	2
P14	7.02.21.291	Vibration preventing rubber	2	2	2
P15	7.02.21.008	Small oil pot	1	1	1
P16	7.02.21.147	Crosstie	1	1	1
P17	7.02.18.077	Rubber pad			
P18	7.02.21.13601	Belt cover			
P19	7.02.15.444	Belt cover screw			
P20	7.02.21.138	Nut			
P21	7.02.21.137	Screw			
P22	7.02.21.139	Spring washer			
P23	7.02.21.095	Belt	1	1	1
P24	7.02.21.050	Thread stand	1	1	1
P25	7.02.21.16401	Oil reservier	1	1	1
P26	7.02.21.157	Wooden screw	9	9	9
P27	7.02.21.550	Knee lifting touch block	1	1	1
P27-1	7.02.21.551	Screw	1	1	1
P27-2	7.02.21.552	Connector	1	1	1
P27-3	7.02.21.553	Screw	1	1	1
P27-4	7.02.21.554	Bend lever	1	1	1
P27-5	7.02.21.555	Bushing	1	1	1
P28	7.02.21.556	Touch block	1	1	1
P29	7.02.21.165	Knee lifting orientation block	1	1	1
P30	7.02.21.162	Knee lifting orientation block screw	1	1	1
P31	7.02.21.153	Roller joint	1	1	1
P32		Roller joint screw	1	1	1
P33	7.02.21.167	Replacement spring	1	1	1
P34	7.02.21.168	Straight lever	1	1	1
P35	7.02.18.021	E-ring	1	1	1
P36	7.02.21.557	Control system connecting line	1	1	1

