

GLOBAL

BT 2900

Bartack

Parts manual

Always switch off the electricity when working on
the machine.

目 录

contents

1. 机体部分 FRAME & MISCELLANEOUS COVER COMPONENTS	1
2. 主轴部分 MAIN SHAFT COMPONENTS	3
3. 针杆部分 NEEDLE BAR COMPONENTS	5
4. 压脚拨线控制部分 PRESSER LIFTER COMPONENTS	7
5. 下轴部分 SHUTTLE DRIVER SHAFT COMPONENTS	9
6. 拨线执行部分 WIPER MECHANISM COMPONENTS	11
7. 线道部分 TENSION RELEASE & THREAD COMPONENTS.....	12
8. 剪线控制传动及剪线执行部分	13
TENSION RELEASE & THREAD TENSION MECHANISM COMPONENTS	
9. 进给及压脚压料部分 FEED MECHANISM COMPONENTS	15
10. 绕线部分 BOBBIN WINDER COMPONENTS	17
11. 安全板部分 SAFETY PLATE COMPONENTS	18
12. 润滑部分 LUBRICATION COMPONENTS	19
13. 电气辅件 SENSOR CABLE COMPONENTS	21
14. 线架部分 THREAD STAND COMPONENTS.....	22
15. 机架台板部分 TABLE COMPONENTS	23
16. 选择件部分 OPTION COMPONENTS	25
17. GE32308D 高速电脑钉扣机	27
GE32308D COMPUTER-CONTROLLED HIGH SPEED BUTTON SEWING MACHINE	
18. 气动抬压脚驱动部分 PNEUMATIC PRESSER LIFTER COMPONENTS.....	33
19. GD22308D-T01 箱包带型电脑加固机.....	35
GD22308D-T01 ELECTRONIC BARTACKING MACHINE FOR BAGS' BELT (RECTANGULAR PATTERN)	
20. GD22308D-T02 伞顶圆型电脑加固机.....	36
GD22308D-T02 ELECTRONIC BARTACKING MACHINE FOR UMBRELLA TOP (CIRCULAR PATTERN)	
21. GD22308D-T03 方结型电脑加固机.....	37
GD22308D-T03 ELECTRONIC BARTACKING MACHINE (SQUARE PATTERN)	
22. GD22308D-T04 装饰钮孔型电脑加固机.....	38
GD22308D-T04 ELECTRONIC BARTACKING MACHINE (DECORATIVE PATTERN)	
23. GD22308D-T05 膨垫型电脑加固机.....	39
GD22308D-T05 ELECTRONIC BARTACKING MACHINE FOR ELASTRIC MATS (CIRCULAR PATTERN)	
24. GD22308D-T06 菊花眼结型电脑加固机.....	41
GD22308D-T06 ELECTRONIC BARTACKING MACHINE FOR STITCHED EYELETS	
25. GD22308D-T07 安全带型电脑加固机.....	42
GD22308D-T07 ELECTRONIC BARTACKING MACHINE FOR SAFETY BELTS	

1. 机体部分

FRAME & MISCELLANEOUS COVER COMPONENTS

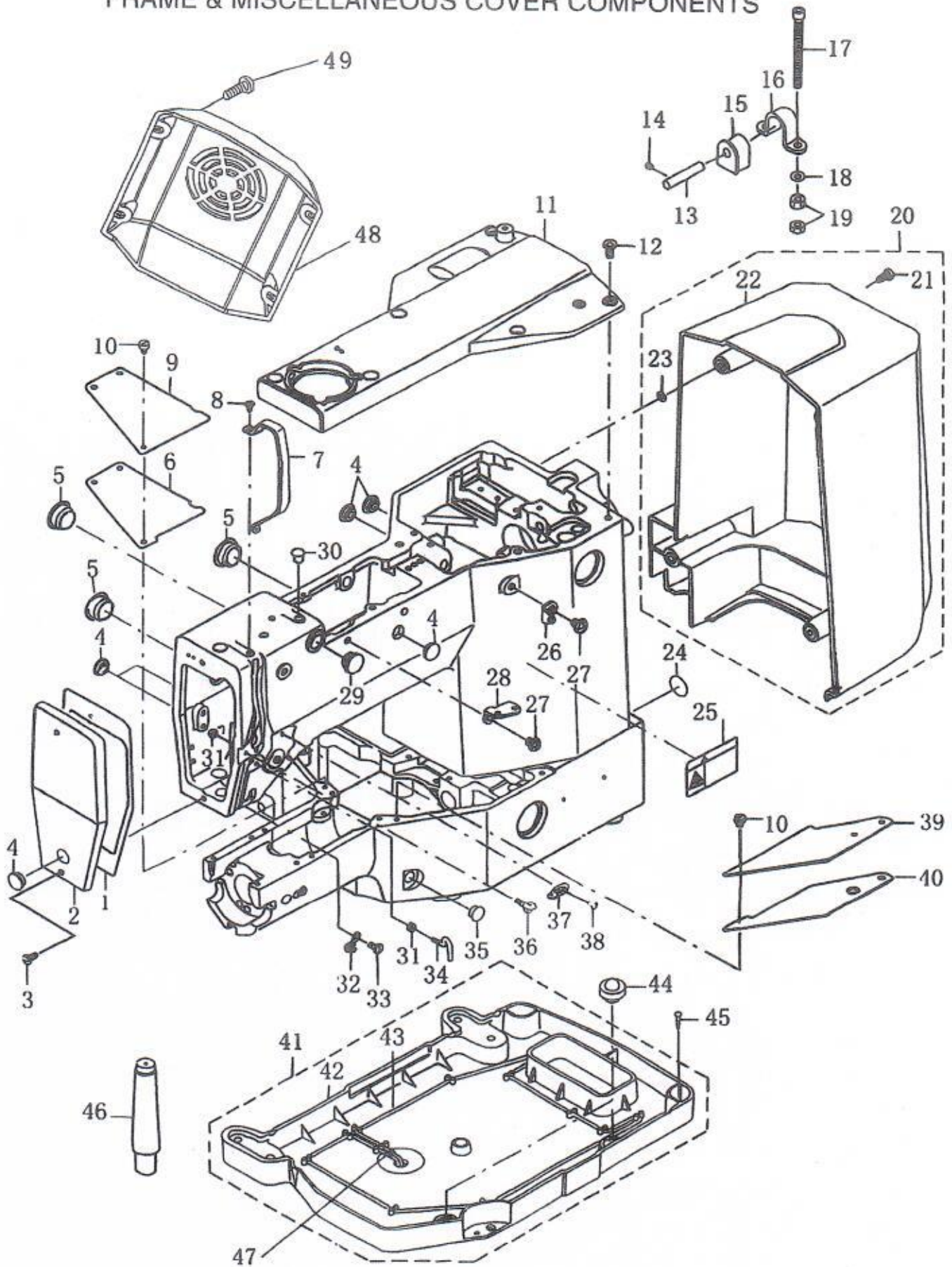

序号	图号	零件名称	Description	数量
1	D8.01-2	垫	FACE PACKING	1
2	D8.01-1	面盖	FACE PLATE ASM.	1
3	FJ65	螺钉SM11/64 × 40 × 10(7 × 2.5)	SCREW 11/64 × 40 L=10	2
4	D8.13-1	橡胶堵	RUBBER PLUG D=12.4 L=4	6
5	D8.13-15	橡胶堵	RUBBER PLUG	3
6	D280119	座盖A密封垫	BED COVER PACKING A	1
7	D8.01-3	挑线护板	BALANCE COVER	1
8	FJ65	螺钉SM9/64 × 40 × 7(6 × 2.5)	SCREW 9/64 × 40 L=7	2
9	D280110	座盖A	BED COVER A	1
10	FJ67	螺钉SM11/64 × 40 × 6(7.8 × 1.5)	SCREW 11/64 × 40 L=6	5
11	D280103	上盖	TOP COVER	1
12	FJ67	螺钉SM15/64 × 28 × 12(10 × 4)	SCREW 15/64 × 28 L=12	6
13	D280117	铰链销	HINGE STUD	2
14	FJ80	螺钉SM11/64 × 40 × 4(2)	SCREW 11/64 × 40 L=4	2
15	D280116	铰链橡胶座	HINGE RUBBER	2
16	D280118	机座铰链架	BED HINGE	2
17	GB65-85	螺钉M6 × 80	HEXAGONAL-HOLE BOLT M6 L=80	5
18	GB96-85	垫圈6	WASHER 6	5
19	GB6170-86	螺母M6	NUT M6	6
20		安全罩组件	SAFETY COVER ASM	1
21	FJ65	螺钉SM11/64 × 40 × 15(10 × 3)	SCREW 11/64 × 40 L=15	(4)
22	D280104G	安全罩	SAFETY COVER	(1)
23	D280105	止推垫	STOPPER	(4)
24	D8.01-32	接地标牌	GROUND MARK	1
25	D280107	警示牌	SAFETY LABEL	1
26	D280705	1号导线板	THREAD GUIDE NO.1	1
27	FJ67	螺钉SM15/64 × 28 × 7(10 × 4)	SCREW 15/64 × 28 L=7	2
28	D8.05-22	过线板	THREAD GUIDE PLATE	1
29	D280108	橡胶堵	RUBBER PLUG	1
30	D8.13-29	橡胶堵	RUBBER PLUG	1
31	FJ6170	螺母SM9/64 × 40(6 × 3)	NUT 9/64 × 40	2
32	D8.05-23	过线勾(B)	ARM THREAD GUIDE B	1
33	FJ67	螺钉SM11/64 × 40 × 7(7 × 2.8)	SCREW 11/64 × 40 L=7	1
34	D8.05-2	挑线过线勾(L形)	L-SHAPED THERAD GUIDE A	1
35	D8.13-12	橡胶堵	RUBBER PLUG	1
36	D8.05-1	缓线过线勾	THREAD GUIDE	1
37	D8.05-24	过线板(A)	ARM THREAD GUIDE A	1
38	FJ67	螺母SM9/64 × 40 × 6(7 × 2.8)	SCREW 9/64 × 40 L=6	1
39	D280112	座盖B	BED COVER B	1
40	D280106	座盖密封垫	BED COVER PACKING B	1
41		机座组件	OIL PAN ASM	1
42	D280109	机座	OIL PAN	(1)
43	FZ339-85	油线Φ3	OIL WICK	(1)
44	D8.01-33	机座橡胶垫	FRAME SUPPORT RUBBER	2
45	GB100-86	木螺钉4 × 30	SCREW D=4 L=30	2
46	D280113	机头支承杆组件	FRAME SUPPORT BAR ASM	1
47	D8.13-5	油线卡	OIL WICK HOLDER	1
48	D2801200	电机罩组件	MOTOR COVER	1
49	GB67	螺钉M4 × 10	SCREW M4 L=10	4

2. 主轴部分

MAIN SHAFT COMPONENTS

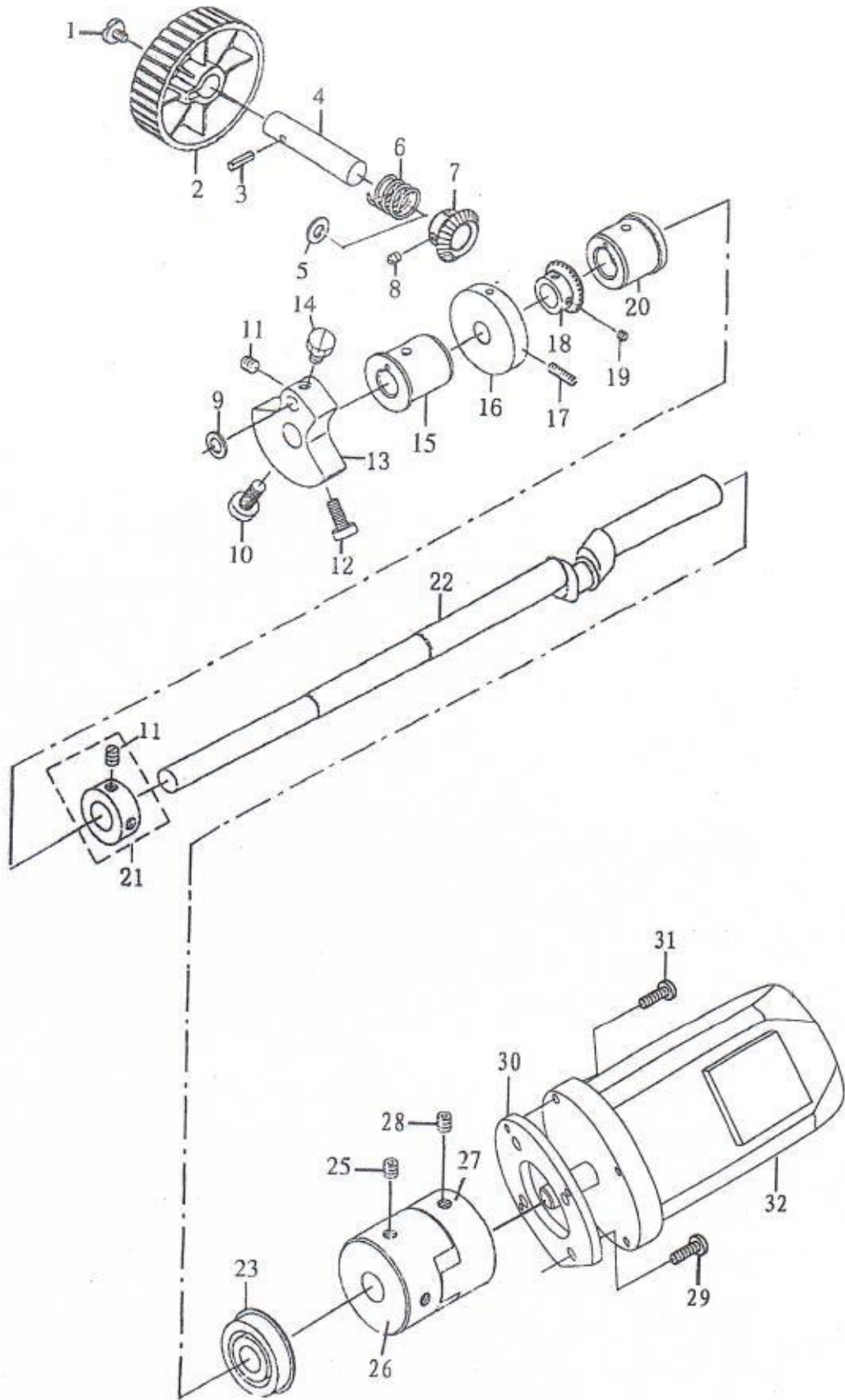

序号	图号	零件名称	Description	数量
1	D280202	手轮紧定螺钉	HANDWHEEL SETSCREW	1
2	D280203	手轮	PULLEY	1
3	GB879-86	销4×14	SPRING PIN 4×14	1
4	D280205	手轮轴	PULLEY SHAFT	1
5	D280220	缓冲垫	CUSHION	1
6	D280204	手轮压簧	SPRING	1
7	5100202	手轮齿轮	HAND PULLEY GEAR	1
8	GB74	螺钉M5×4	SCREW M5×4	1
9	D8.02-1	调整垫圈	NEEDLE ROD CRANK WASHER	2
10	D8.02-2	锥形螺钉	SCREW	1
11	FJ80	螺钉SM1/4×40×6	SCREW 1/4×40 L=6	3
12	FJ70	螺钉SM15/64×28×14(9×5.8×5)	SCREW 15/64×28 L=14	1
13	D8.02-3	针杆曲柄	COUNTER WEIGHT	1
14	FJ29.1	螺钉SM1/4×40×12(9×4)	SCREW 1/4×40 L=12	1
15	D280207	主轴前套	MAIN SHAFT FRONT BUSHING	1
16	D280208	底线绕线驱动轮	BOBBIN WINDER DRIVING WHEEL	1
17	GB74	螺钉M6×6	SCREW M6×6	2
18	5100202	手轮齿轮	HAND FULLEY GEAR	1
19	GB74	螺钉M5×5	SCREW M5×5	2
20	D280211	主轴中套	MAIN SHAFT CENTER WHEEL	1
21	D280212	挡圈	THRUST COLLAR ASM	1
22	D28A0210	主轴	MAIN SHAFT	1
23	6302 NR.ZZ	单列球轴承	UPPER SHAFT REAR BEARING	1
24				
25	GB80-85	螺钉M6×6	SCREW M6 L=6	2
26	D300212	主轴联轴器	MAIN SHAFT COUPLING	1
27	D300211	电机轴联轴器	MAIN MOTOR COUPLING	1
28	GB80-85	螺钉M6×16	SCREW M6 L=16	1
29	FJ67	螺钉SM11/64×40×14(7×2.8)	SCREW 11/64×40 L=14	4
30	D280221	电机板	MOTOR BASE	1
31	GB70	螺钉M5×15	SCREW M5 L=15	3
32		主轴电机 400W	MAIN MOTOR	1

3. 针杆部分

NEEDLE BAR COMPONENTS

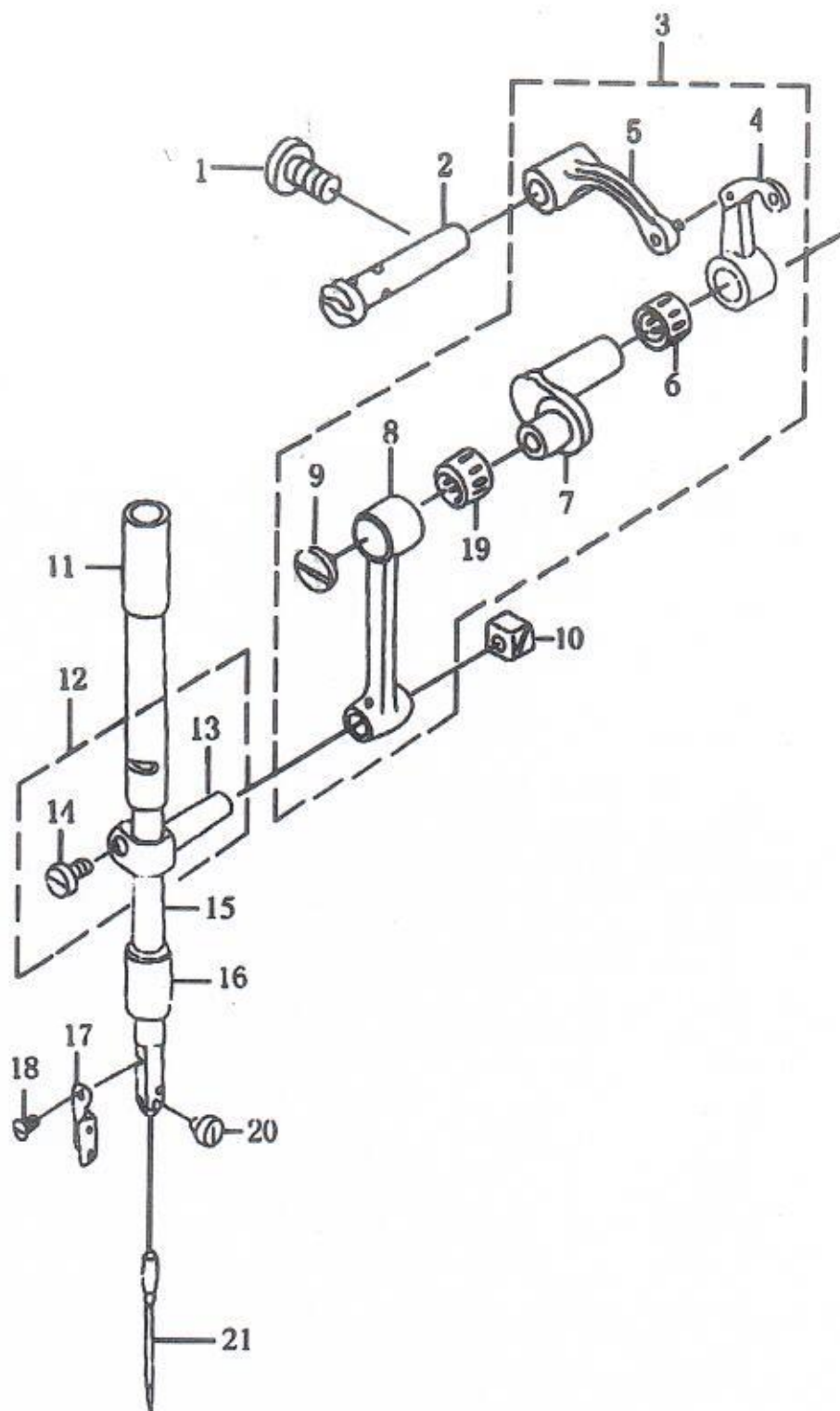

序号	图号	零件名称	Description	数量
1	FJ65	螺钉SM15/64 × 28 × 11(7.5 × 3)	SCREW 15/64 × 28 L=11	1
2	D8.15-2	挑线杆轴	BALANCE CRANK PIN	1
3		挑线联杆平衡组件	LINK BALANCE ASM.	1
4	D8.15-8	挑线杆	THREAD TAKE-UP LEVER	1
5	D8.15-3	挑线摇杆	THREAD TAKE-UP CRANK	1
6	GB5846-86	滚针轴承DKS081208	NEEDLE BUSHING	1
7	D8.15-9	针杆曲柄联杆	NEEDLE ROD CRANK	1
8	D8.15-11	针杆联杆	NEEDLE BAR CRANK ROD	1
9	D.815-10	左旋螺钉	LEFT SCREW	1
10	D.815-12	滑块	SQUARE BLOCK	1
11	D8.15-1	针杆上套	NEEDLE ROD METAL	1
12		针杆连接组件	NEEDLE BAR CONNECTING ASM.	1
13	D8.15-5	针杆连接轴	NEEDLE BAR CLAMP	1
14	FJ65	螺钉SM9/64 × 40 × 6(6 × 2.5)	SCREW 9/64 × 40 L=6	1
15	D8.15-4	针杆	NEEDLE BAR	1
16	D8.15-1	针杆下套	NEEDLE ROD LOWER METAL	1
17	D280301	针杆导线器	NEEDLE BAR THREAD GUIDE	1
18	FJ69	螺钉SM3/32 × 56 × 4.5(Φ3.9)	SCREW 3/32 × 56 L=4.5	1
19	GB5846-86	滚针轴承DKS081110	NEEDLE DRIVING LEVER BEARING	1
20	FJ65	螺钉SM1/8 × 44 × 3(5 × 1.5)	SCREW 1/8 × 44 L=3	1
21	DP × 5	机针(14#, 16#)	NEEDLE DP × 5(14#,16#)	1

4. 压脚拨线控制部分

PRESSER LIFTER COMPONENTS

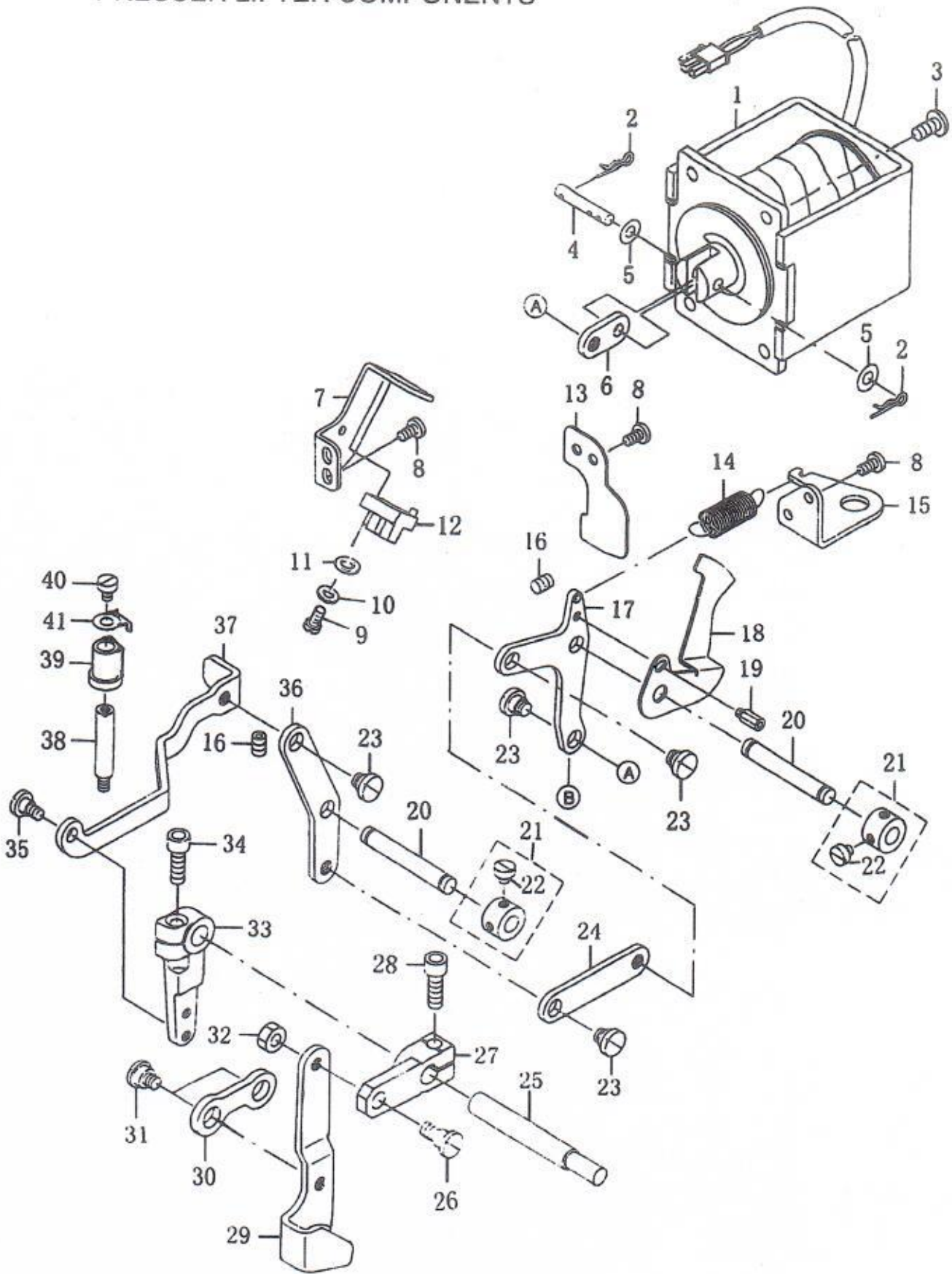

序号	图号	零件名称	Description	数量
1	D2804110	升降压脚电磁铁组件	PRESSER LIFTING SOLENOID ASM.	1
2	D280420	夹紧销	PIN	2
3	FJ65	螺钉SM15/64 × 28 × 14(10 × 4)	SCREW 15/64 × 28 L=14	4
4	D280419	电磁铁销轴	MAGNET PIN	1
5	GB97.1	垫圈5	WASHER	2
6	D280414	电磁铁连杆	PRESSER SOLENOID LINK	1
7	D280402	传感器固定板	SENSOR IWSTALLING PLATE	1
8	FJ67	螺钉SM11/64 × 40 × 7.8(8 × 2.2)	SCREW SM11/64 × 40 L=7.8	1
9	GB818	螺钉M3 × 10	SCREW M3 × 10	1
10	GB859	垫圈3	WASHER	1
11	GB97.1	垫圈3	WASHER	1
12		传感器	SENSOR	1
13	D280404	隔板	PLATE	1
14	D8.22-5	拉力弹簧	SPRING	1
15	D280401	弹簧挂钩	SPRING SUSPENSION	1
16	FJ80	螺钉SM15/64 × 28 × 8(3)	SCREW 15/64 × 28 L=8	2
17	D280412	提升连杆D	LIFTING LINK D	1
18	D280403	压脚升降传感器切片	PRESSER SENSOR SLIT	1
19	5101543	连接螺钉	SCREW	1
20	D8.21-20	转轴	SHAFT BLOCK SHAFT	1
21	D280413	紧圈组件D=7.94 W=10	THRUST COLLAR ASM. D=7.94 W=10	2
22	FJ65	螺钉SM11/64 × 40 × 5(5.5 × 1.5)	SCREW 11/64 × 40 L=5	4
23	D280405	铰接螺钉D=8 H=3.4	HINGE SCREW D=8 H=3.4	4
24	D280418	提升连杆C	LIFTING LINK C	1
25	D280408	升降轴	PRESSER LIFTING SHAFT	2
26	D8.07-10	螺钉轴 D=7.94 H=6	HINGE SCREW D=7.94 H=6	1
27	D280407	摆臂	ARM	1
28	GB70-85	螺钉M6 × 18	SCREW M6 L=18	1
29	D280409	升降压杆	LOWERING FOOT	1
30	D280406	连杆	CONNCTING ROD	1
31	D8.07-9	螺钉轴	HINGE SCREW D=10 H=4	2
32	FJ6170	螺母SM15/64 × 28(9 × 3)	NUT 15/64 × 28	1
33	D8.04-8	联杆	CONNECTING ARM	1
34	FJ70	螺钉SM15/64 × 28 × 16.5(9.8 × 5.8 × 5)	SCREW 15/64 × 28 L=16.5	1
35	D8.04-18	螺钉轴	HINGE SCREW D=6.35 H=3.9	1
36	D280417	提升连杆B	LIFTING LINK B	1
37	D280415	提升连杆A	LIFTING LINK A	1
38	D280416	支撑螺钉	OIL PUMP SUPPORT	1
39	D2804210	减振橡胶圈组件	RUBBER BUSH	1
40	FJ65	螺钉SM11/64 × 40 × 6(8 × 1.3)	SCREW 11/64 × 40 L=6	1
41	D280422	定位板	STOR LEVER	1

5. 下轴部分

SHUTTLE DRIVER SHAFT COMPONENTS

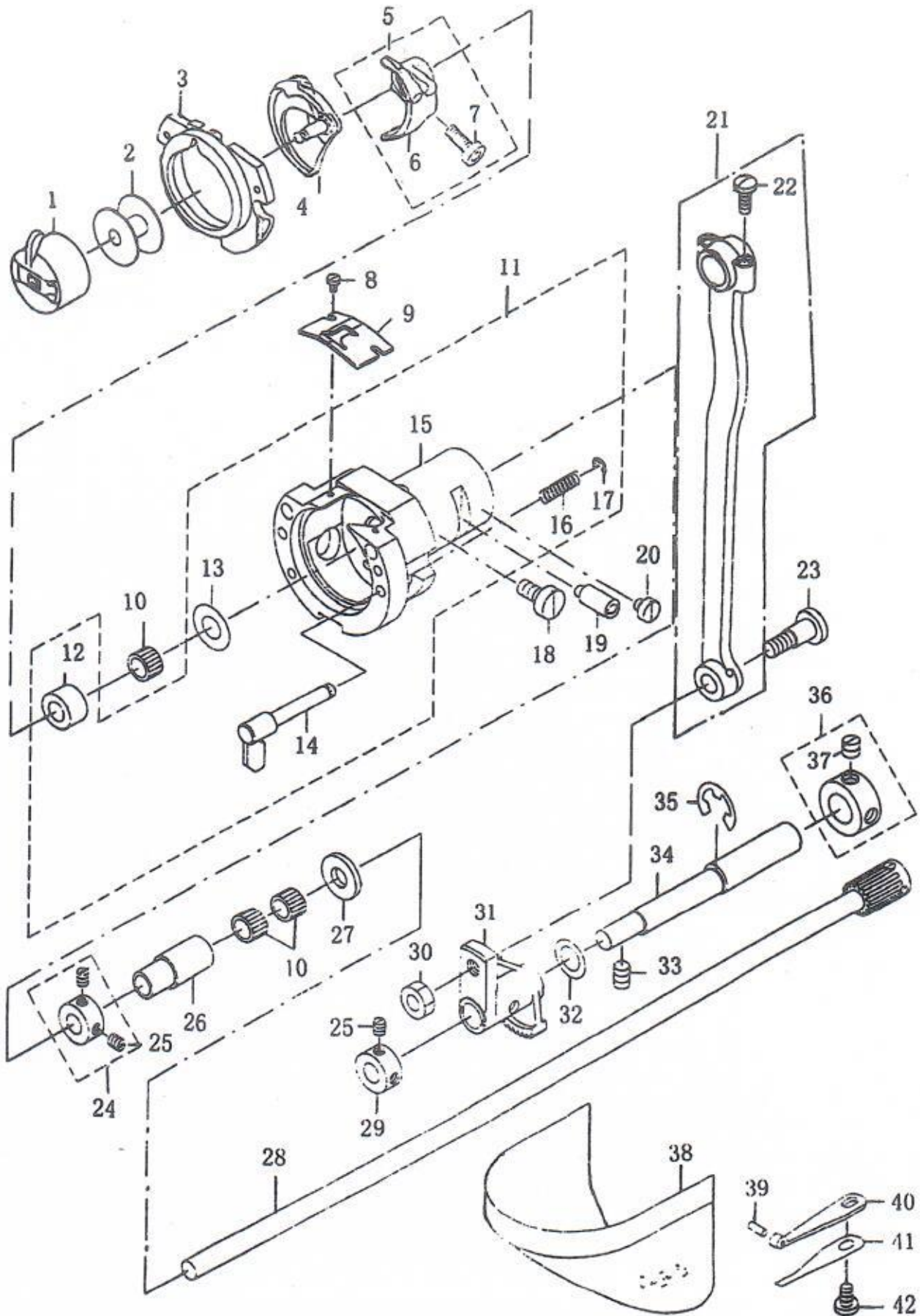

序号	图号	零件名称	Description	数量
1	D280511	梭芯套	BOBBIN CASE ASM.(RACING PREVENT)	1
2	D280515	梭芯	BOBBIN	1
3	D280502	梭床盖B	INNER HOOK PRESSER ASM.	1
4	Y01.08-24 B1818-280-000	梭床销 摆梭	GUIDE PIN INNER HOOK	(2) 1
5	D8.14-3	梭托组件	DRIVER ASM.	1
6	FJ70	梭托	SHUTTLE DRIVER	(1)
7	GB65	螺钉SM3/16 × 28 × 12(7.5 × 4)	SCREW 3/16 × 28 L=12	(1)
8	GB65	螺钉M2.5 × 3	SCREW M2.5 × 3	2
9	5100511	梭床分线板	SHUTTLE UPPER SPRING	1
10	GB5846-86	轴承DKS81110	BEARING	3
11	D8.14-4	梭床体组件	SHUTTLE ASM.	1
12	D8.14-4	下轴前套	SHUTTLE NEEDLE OUTER PING	(1)
13	D8.14-5	垫圈	WASHER	(1)
14	D2805100	压杆组件	INNER HOOK PRESSER ASM.	(2)
15	5100504	梭床体	SHUTTLE	(1)
16	D280509	压簧	INNER HOOK PRESSER SPRING	(2)
17	GB896-86	挡圈3	E-RING 3	(2)
18	FJ65	螺钉SM15/64 × 28 × 11.5(8 × 5)	SCREW 15/64 × 28 L=11.5	1
19	D8.14-15	调节轴	SHUTTLE RACE ADJUSTING SHAFT	1
20	FJ65	螺钉SM11/64 × 40 × 5(8.2 × 1.4)	SCREW 11/64 × 40 L=5	1
21	D2805070	摆梭连杆组件	CRANK ROD ASM.	1
	D2805071	摆梭连杆	CRANK ROD	(1)
	D2805072	连杆盖	ROD COVER	(1)
22	FJ65	螺钉SM11/64 × 40 × 10.5(6.5 × 3.2)	SCREW 11/64 × 40 L=10.5	(2)
23	5100515	螺钉轴	HINGE SCREW D=8 H=10.2	1
24	D8.14-8	挡圈组件	THRUST COLLAR ASM. D=8 W=8	2
25	FJ80	螺钉SM11/64 × 40 × 4	SCREW 11/64 × 40 L=4	6
26	D8.14-9	下轴后套	LOWER SHAFT REAR MATAL	1
27	D8.14-19	垫圈	LOWER SHAFT THRUST WASHER	1
28	D280504	下轴组件	LOWER SHAFT GEAR A ASM.	2
	5100506	下轴	SHUTTLE DRIVER SHFT	(1)
	GB117	小齿轮	GEAR	(1)
	GB74	销3 × 16	PIN	(1)
		螺钉M5 × 4	SCREW M5 × 4	(1)
29	D280512	前挡圈	THRUST COLLAR	1
30	GB6170	螺母M6 × 0.75	NUT M6 × 0.75	1
31	5100514	摆动齿轮	OSCILLATOR	1
32	D280514	垫圈	WASHER	1
33	FJ80	螺钉SM15/64 × 28 × 8(3)	SCREW 15/64 × 28 L=8	2
34	D280506	摆动齿轮偏心轴	OSCILLATING ECCENTRIC SHAFT	1
35	GB896-86	挡圈9	E-RING 9	1
36	D280508	后挡圈组件	THRUST COLLAR ASM. D=12 W=10	1
37	FJ80	螺钉SM1/4 × 40 × 6	SCREW 1/4 × 40 L=6	2
38	D8.14-1.1	罩盖组件	CYLINDER ASM. CAP	1
39	GB119-86	销B2 × 10	HOOK COVER PRESSER SPRING PIN	1
40	D8.14-18	罩盖弹簧板(A)	HOOK COVER PRESSER SPRING A	1
41	D8.14-17	罩盖弹簧板(B)	HOOK COVER PRESSER SPRING B	1
42	FJ65	螺钉SM11/64 × 40 × 11(10 × 3)	SCREW 11/64 × 40 L=11	1

6. 拨线执行部分

WIPER MECHANISM COMPONENTS

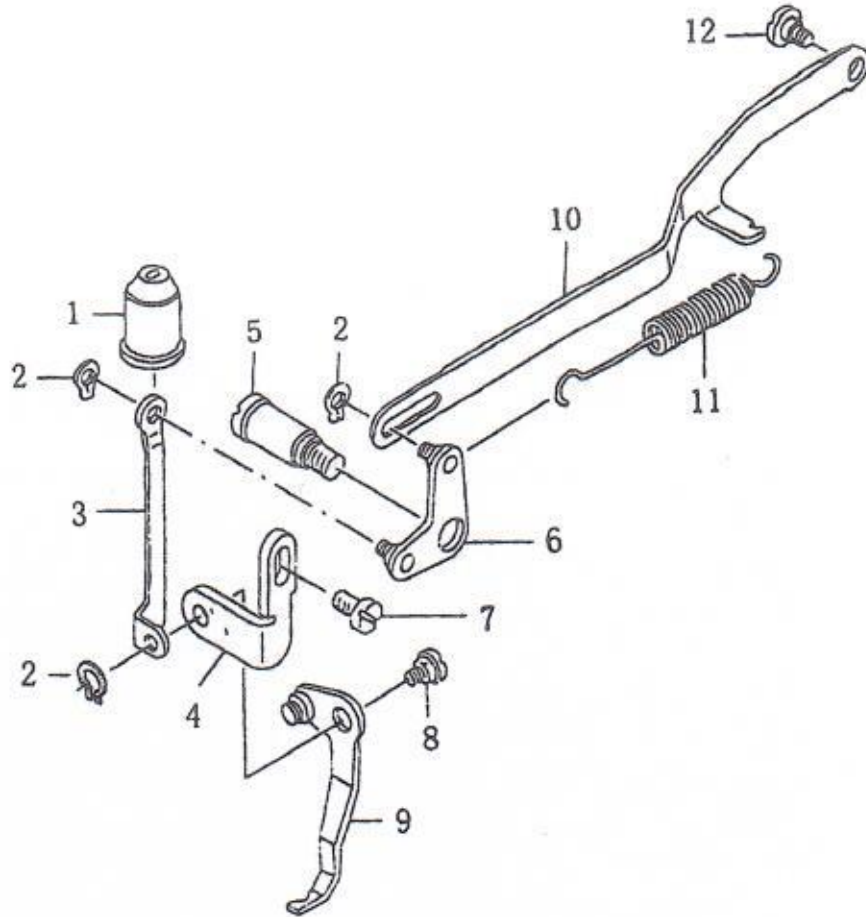

序号	图号	零件名称	Description	数量
1	D8.04-3	密封罩	OIL SHIELD CAP	1
2	GB894.1-86	挡圈	RETAINING RING 5	3
3	D8.04-1	连接板	WIPER CONNECTING PLATE	1
4	D280601	接线杆座	WIPER BASE PLATE	1
5	D8.04-16	螺钉轴	WIPER CONNECTING SCREW	1
6	D8.04-5.2	拨线杠杆组件	WIPER CONNECTING ARM ASM.	1
7	FJ65	螺钉SM11/64 × 40 × 8(8 × 2.5)	SCREW 15/64 × 40 L=8	1
8	D8.04-19	螺钉轴	HINGE SCREW D=6.35 H=2.1	1
9	S1006010	拨线杠杆组件	WIPER ASM.	1
10	D8.04-7	前拉杆	WIPER CONNECTING LINK	1
11	D8.04-6	拉簧	SPRING	1
12	D8.04-17	螺钉轴	HINGE SCREW D=5.3 H=2.2	1

7. 线道部分

TENSION RELEASE & THREAD TENSION COMPONENTS

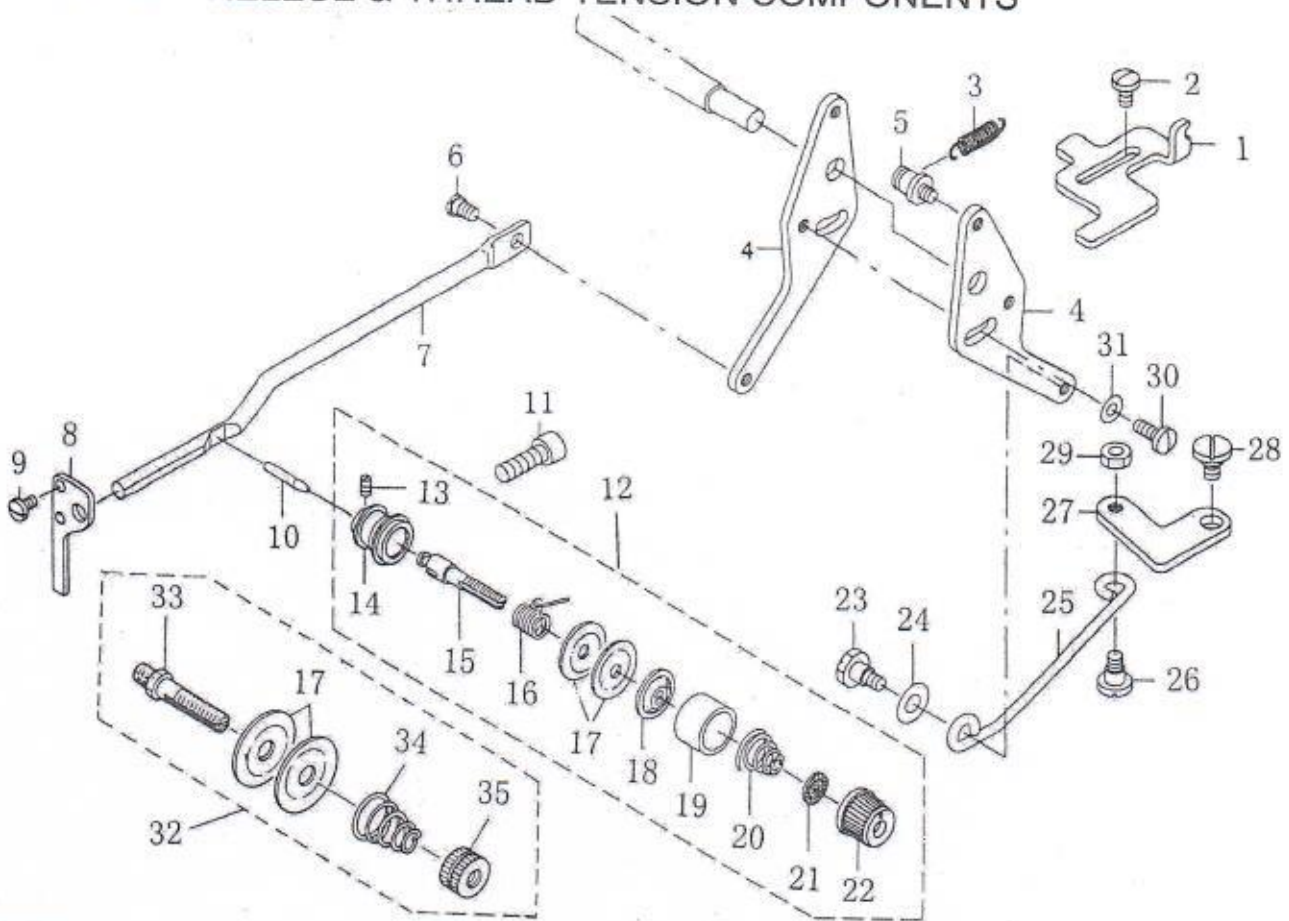

序号	图号	零件名称	Description	数量
1	D280704	调节板止动器	ADJUSTING ARM STOPPER	1
2	D8.11-15	螺钉	SCREW 11/64 × 40 L=8	2
3	D280703	拉簧	PRESSURE SPRING	1
4	D280701	挂线调节板	TENSION RELEASE ADJUSTING ARM	2
5	D280702	挂簧螺钉	SUSPENSION SCREW	1
6	D8.05-5	螺钉轴	HINGE SCREW D=5.3 H=2.2	1
7	D8.05-4	松线杆	TENSION RELEASE BAR	1
8	D8.05-6	支撑板	THREAD TENSION ARM	1
9	FJ67	螺钉 SM9/64 × 40 × 6(5.5 × 1.5)	SCREW 9/64 × 40 L=6	2
10	D280711	支线销	TENSION RELEASE PIN	1
11	FJ29.1	螺栓 SM15/64 × 28 × 17(9 × 4)	SCREW 15/64 × 28 L=17	1
12		第二夹线器组件	SECOND THREAD TENSION ASM.	1
13	FJ75	螺钉 SM9/64 × 40 × 5.9(2.5 × 1)	SCREW 9/64 × 40 L=5.9	(1)
14	D8.05-7	夹线座	THREAD TENSION ROD LARGE	(1)
15	D8.05-11	夹线螺轴(2号)	THREAD TAKE-UP SPRING	(1)
16	F81525	挑线弹簧	TAKE-UP SPRING (HEAVY)	(1)
17	D8.05-15	夹线盘	THREAD TENSION DISK	(4)
18	D8.05-8	松线顶板	THREAD TENSION DISK PRESSER	(1)
19	Y01.06-1	弹簧盒	TENSION DISK PRESSER TUBE	(1)
20	D8.05-9	夹线器 II 压簧	TENSION SPRING	(1)
21	D8.05-10	夹线杆垫圈	ROTATING STOPPER	(1)
22	D8.05-12.1	调节旋钮 A	THREAD TENSION NUT	(1)
23	D280707	铰接螺钉 D=6.35 H=4.8	HINGE SCREW D=6.35 H=4.8	1
24	SJ08 A18-8	垫圈	WASHER	1
25	D280710	松线连杆	TENSION RELEASE CONNECTING ROD	1
26	D8.04-18	螺钉轴	HINGE SCREW D=6.35 H=3.9	1
27	D280709	松线连板	TENSION RELEASE LINK	1
28	D280708	铰接螺钉	HINGE SCREW	1
29	FJ6170	螺母 SM3/16 × 28(7 × 3)	NUT 3/16 × 28	1
30	FJ65	螺钉 SM11/64 × 40 × 10.5(7 × 2.5)	SCREW 11/64 × 40 L=10.5	1
31	F81804	垫圈	WASHER	1
32		第一夹线器组件	FIRST THREAD TENSION ASM.	1
33	D8.05-14	压线盘螺栓(1号)	THREAD TENSION ROD	(1)
34	D280706	第一夹线器弹簧	FIRST THREAD TENSION SPRING	(1)
35	D8.05-13	调节螺母	TENSION NUT, NO.1	(1)

8. 剪线控制传动及剪线执行部分

TENSION RELEASE & THREAD TRIMMER MECHANISM COMPONENTS

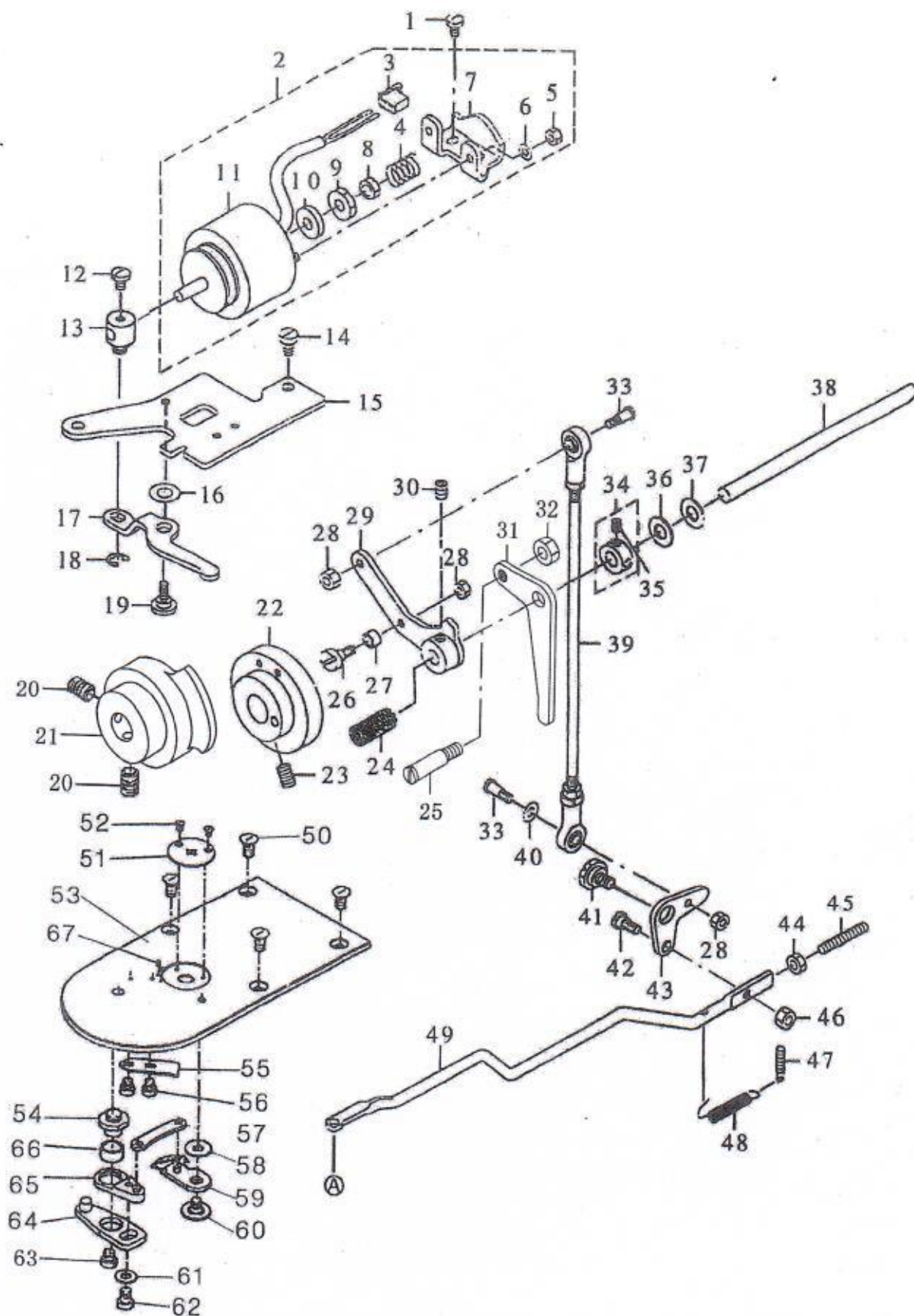

序号	图号	零件名称	Description	数量
1	GB/T 70.1	螺钉 M4×6	SCREW M4 L=6	2
2	5310112	左扣夹 A	CLAMP JAM LEVER, LEFT	1
3	5310103	夹板	BUTTON CLAMP	2
4	5310110	螺钉轴 A	HINGE SCREW	2
5	5310127	连杆	LINK	1
6	GB/T 97.1	垫圈 2	WASHER 2	2
7	602X	轴承 $\phi 2.5 \times \phi 8 \times 2.8$	BEARING	2
8	GB/T 67	螺钉 M2.5×7	SCREW M2.5 L=7	2
9	GB/T 67	螺钉 M2.5×10	SCREW M2.5 L=10	1
10	5310122	中心定位块 A	BUTTON CLAMP SLIDE	1
11	5310137	螺钉轴	HINGE SCREW	1
12	5310115	滑动定位块	STATION BLOCK	1
13	5310111	右扣夹 A	CLAMP JAM LEVER, RIGHT	1
14	GB/T 6172.1	薄螺母 M4	NUT M4	1
15	5310101	导向板	GUIDE PLATE	1
16	5310131	螺钉 A	SCREW	2
17	5300304	支撑板	ACCEPT PLATE UPPER	1
18	FJ 65	螺钉 SM11/64×40×7.8(8×2)	SCREW 11/64-40 L=7.8	2
19	E380307	压缩弹簧	SPRING	1
20	5310118	支撑轴	ADJUSTING SHAFT	1
21	5101523G	螺母 C	NUT	1
22	5101536	螺母 B	NUT	1
23	5310105	支撑座	ACCEPT PLATE BASE	1
24	GB/T 70.1	螺钉 M4×8	SCREW M4 L=8	2
25	GB/T 70.1	螺钉 M4×12	SCREW M4 L=12	2
26	GB/T 96.1	垫圈 4	WASHER 4	5
27	5310130	提升杆	MOVING PLATE	1
28	GB/T 70.1	螺钉 M5×8	SCREW M5 L=8	2
29	GB/T 97.1	垫圈 5	WASHER 5	5
30	GB/T 6170	螺母 M4	NUT M4	2
31	5310129	提升座板	MOVING PLATE BASE	1
32	53101250	扣夹座板组件	PICK-UP FOOT INSTALLING BASE	1
33	GB/T 6184	螺母 M5	NUT M5	2
34	5310126	旋扭螺钉	SCREW	1
35	5310124	滑块 B	SLIDE BLOCK	1
36	53101280	扣夹开合调节板组件	INDICATOR LEVER	1
37	5310132	螺钉轴 C	HINGE SCREW	1
38	GB/T 5783	螺栓 M3×4	BOLT M3 L=4	1
39	GB/T 97.1	垫圈 3	WASHER 3	1
40	GB/T 70.1	螺钉 M6×15	SCREW M6 L=15	1
41	GB/T 96.1	垫圈 6	WASHER 6	1
42	53101080	转轴座组件	PICK-INSTALLING BASE	1
43	5310109	转轴	INSTALLING SHAFT	1
44	53101190	连接板组件	INSTRALLING BASE	1
45	5310136	进给板 C	CLOTH FEED PLATE	1
46	GB/T 5783	螺栓 M3×8	BOLT M3 L=8	4
47	GB/T 5783	螺栓 M5×16	BOLT M5 L=16	1
48	53101200	支撑座组件	BRACKET BASE	1
49	53101214	连杆	LINK SHAFT	1
50	53101390	进给垫板 B 组件	CLOTH FEED PLATE BASE	1
51	GB/T 97.1	垫圈 3	WASHER 3	2
52	GB/T 5783	螺栓 M3×4	BOLT M3 L=4	2
53	5310133	转套	SLIDE ROLLER	2
54	D8.16-13	调整垫 ($\delta 0.9$)	WASHER	1
55	GB/T 5783	螺栓 M4×8	BOLT M4 L=8	1
56	5310134	垫圈	WASHER	4
57	GB/T 5783	螺栓 M4×16	BOLT M4 L=16	2
58	53101380	送料板 C 组件	PRESSURE PLATE	1
59	5310104	弹簧	SPRING	1
60	5310209	支架	HOLDER	1
61	GB/T 67	螺钉 M4×8	SCREW M4 L=8	1
62	GB/T 97.1	垫圈 4	WASHER 4	1

(4). 附件 ACCESSORIES PARTS

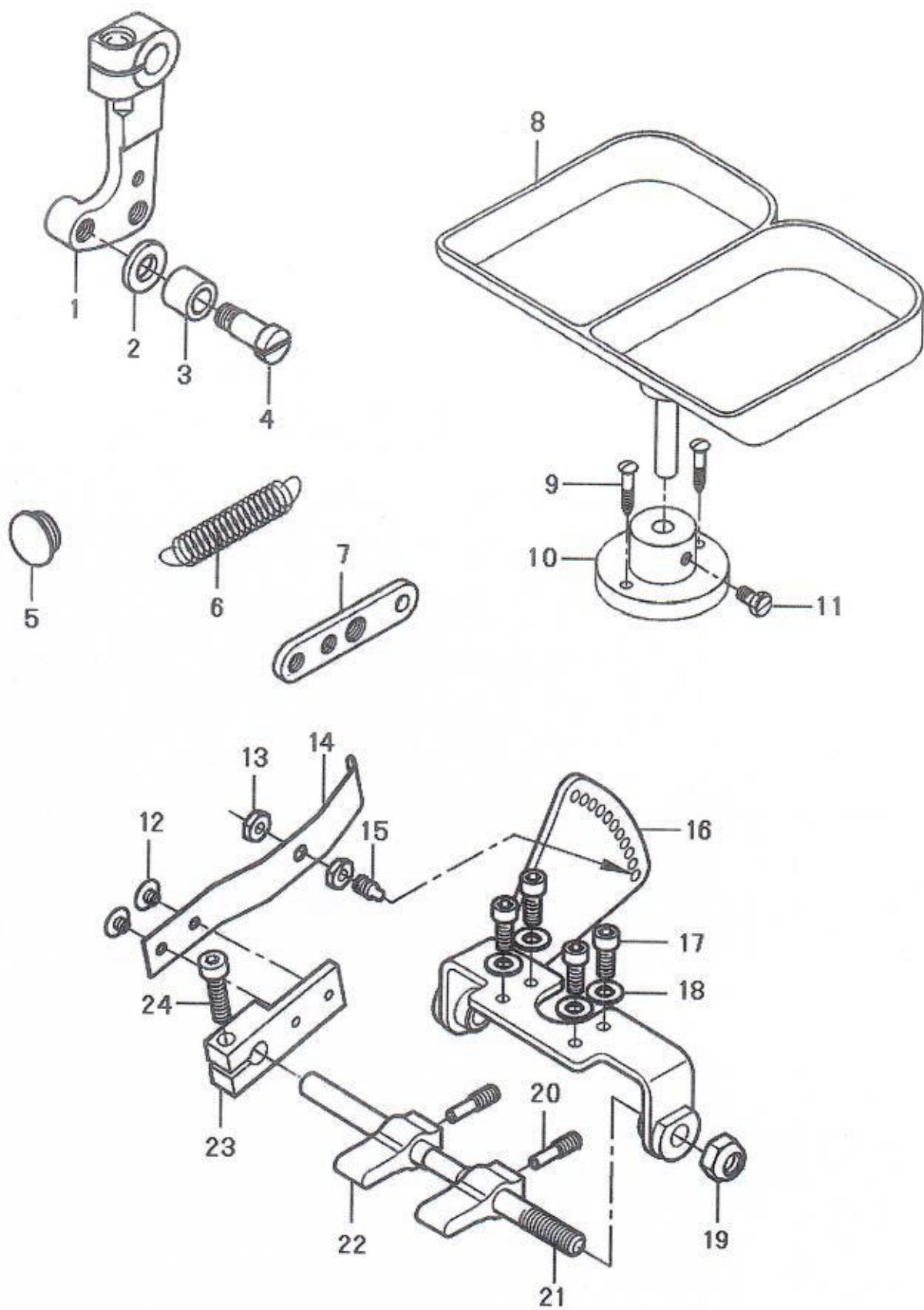

序号	图号	零件名称	Description	数量
1	D8.21-6	联动摆杆 B	CONNECTING ASM.	1
2	E380343	垫圈	HOOK SHAFT WASHER	1
3	E380342	转子	STOP MOTION TRIPPING LEVER CAM	1
4	E380303	螺钉轴	HINGE SCREW D=7.94 H=12.7	1
5	D8.13-15	橡胶堵	RUBBER PLUG	1
6	E380301	拉簧	TENTION SPRING	1
7	E380302	连杆	SOLENOID LINK	1
8	E802250	托盘组件	BUTTON TRAY ASM.	1
9	GB845	自攻螺钉 ST4.2×19	WOOD SCREW D=4.2 L=19	2
10	E380601	托盘底座	BUTTON TRAY BASE	1
11	GB/T 29.1	螺栓 M6×12	SCREW M6 L=12	1
12	53101213	螺钉	SCREW	2
13	GB/T 6172.1	螺母 M4	NUT M4	2
14	5310205	弹簧板	SPRING PLATE	1
15	GB/T 75	螺钉 M4×10	SCREW M4 L=10	1
16	53102010	支撑板组件	ACCEPT PLATE	1
17	GB/T 70.1	螺钉 M4×8	SCRES M4 L=8	4
18	GB/T 97.1	垫圈 4	WASHER 4	4
19	GB/T 6184	螺母 M6	NUT M6	1
20	5310204	螺纹销	SCREW PIN	2
21	5310203	摆杆轴	DRIVING ARM SHAFT	1
22	5310202	摆杆	DRIVING ARM	2
23	5310206	连杆	CONNECTING ARM	1
24	GB/T 70.1	螺钉 M4×16	SCRES M4 L=16	1

18. 气动抬压脚驱动部分

PNEUMATIC PRESSER LIFTER COMPONENTS

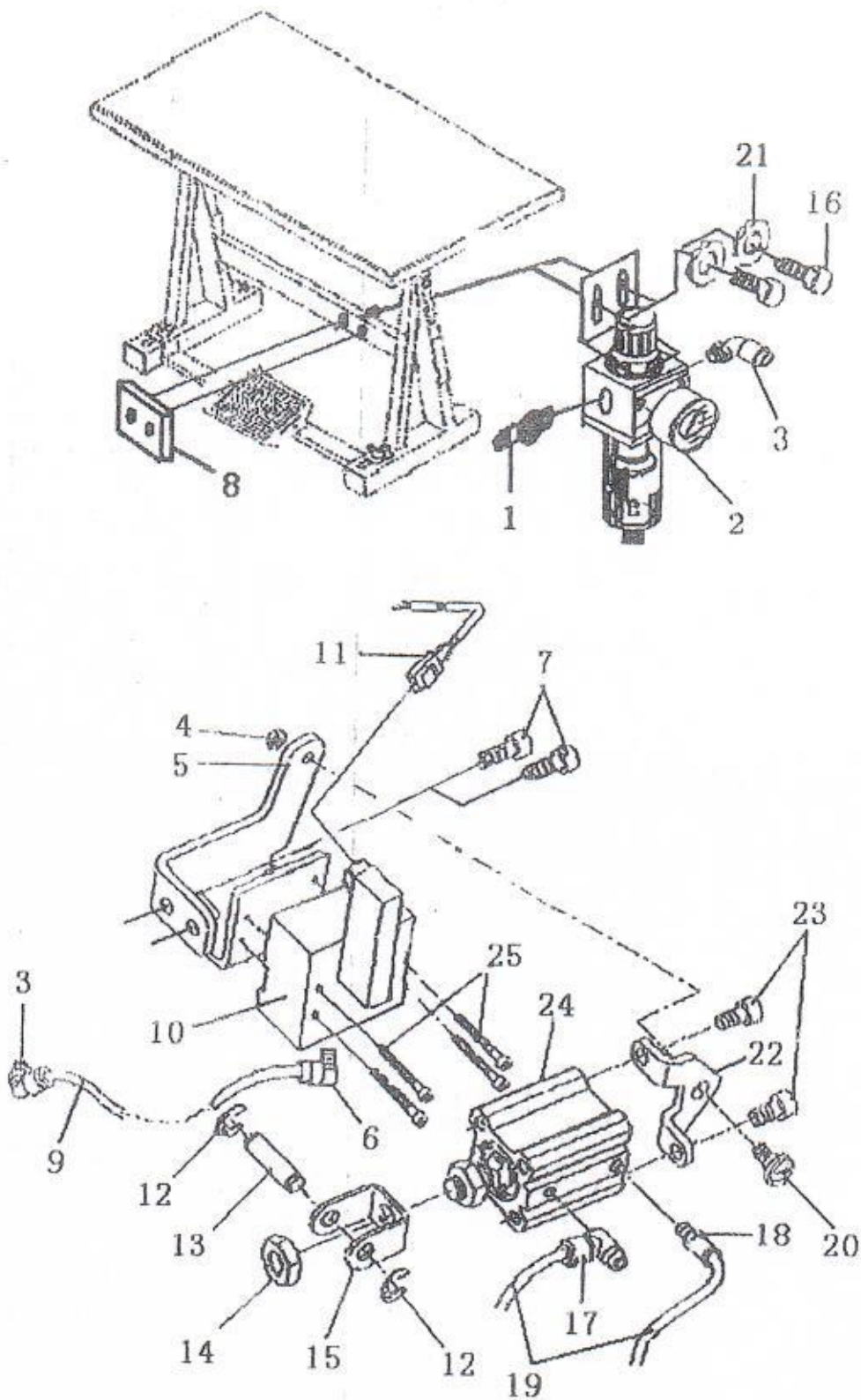

序号	图 号	零 件 名 称	Description	数量
1	PM20	快速接头	Connection	1
2	QFLJC-L8	空气过滤减压阀	Filter	1
3	FPH4-02	F型可旋转气动快插管接头	WL-E connection	1
4	GB 6170	螺母 M6	Nut M6	1
5	5101544	基座	Holder	1
6	FPH4-01	F型可旋转气动快插管接头	Connection	1
7	FJ 70	螺钉 SM15×28×16.5(9.8×5.8×5)	Screw SM15×28×16.5	2
8	D281801	固定板	Fixing plate	1
9	PUN-4×0.75-SW	聚胺酯气管	Hose 2.7LW×0.65	1 米
10	169113	电控换向阀	Connecting block right	1
11	644067	电磁阀电缆接头	Wire	1
12	GB 896	挡圈 6	Retaining ring 7	1
13	5101547	连接轴	Pin	1
14	GB 6170	螺母 M10×1.25	Nut M10×1.25	1
15	5101546	连接架	Connector	1
16	GB 70	螺钉 M4×10	Screw M4×10	2
17	FJSC4-M5	调速阀	Connection M5 D4	1
18	FPH4-M5	F型可旋转气动快插管接头	Choke valve	1
19	PUN-4×0.75-SW	聚胺酯气管	Hose 2.7LW×0.65	2×220
20	5101548	铰接轴	Hinge screw	1
21	GB 96	垫圈 4	Washer 4	2
22	5101545	摆架	Flange	1
23	GB 70	螺钉 M6×12	Screw M6×12	1
24	CQ2A25-25DCM	气缸	Cylinder	1
25	GB 70	螺钉 M3×30	Screw M3×30	4

19. GD22308D-T01 箱包带型电脑加固机

GD22308D-T01 ELECTRONIC BARTACKING MACHINE FOR BAG'S BELT (RECTANGULAR PATTERN)

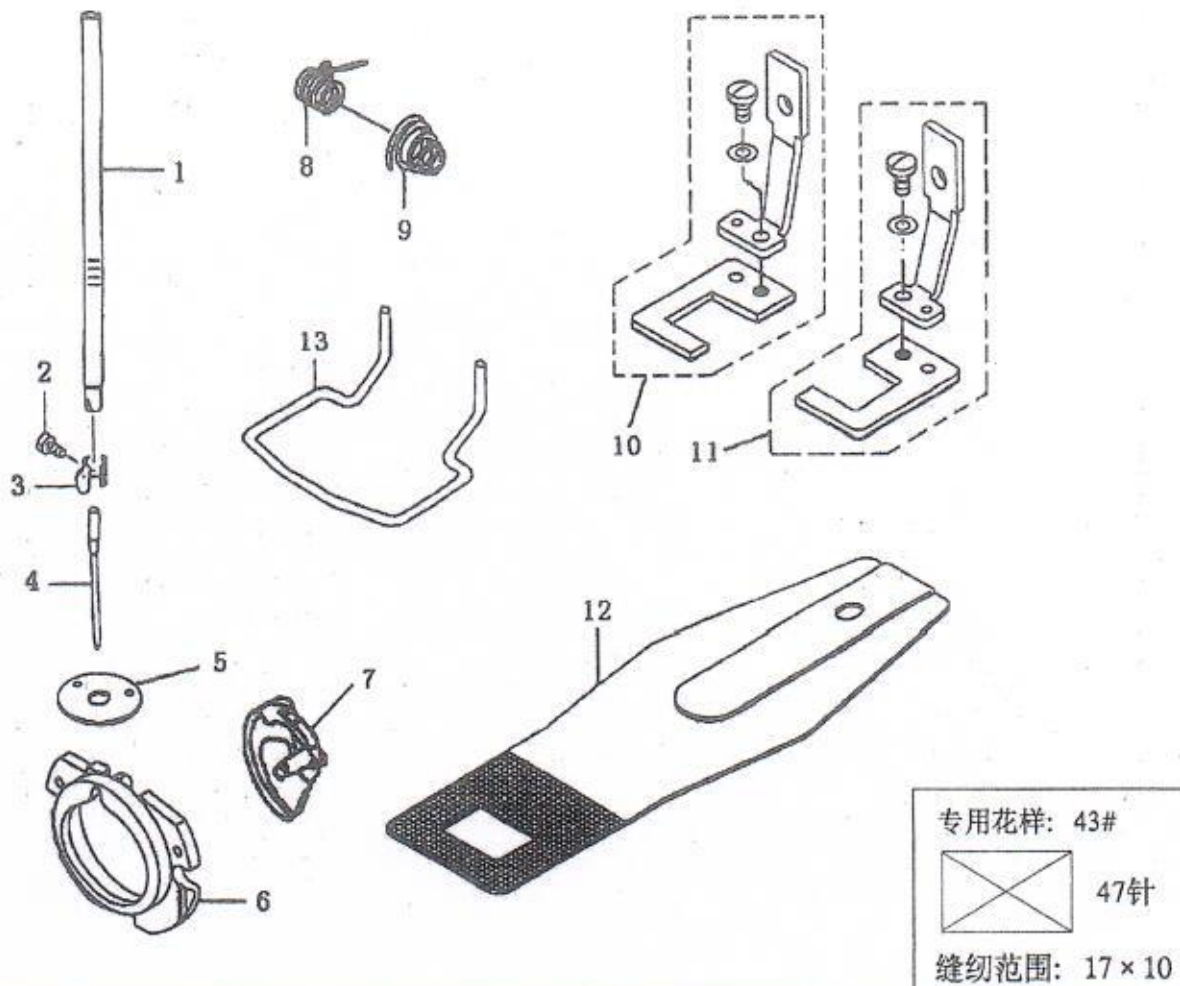

序号	图号	零件名称	Description	数量
1	E380206	针杆	NEEDLE BAR	1
2	FJ65	螺钉SM1/8 × 44 × 4.5(5 × 1.5)	SCREW 1/8 × 44 × 4.5(5 × 1.5)	1
3	E380207	过线板	THREAD GUIDE	1
4	DP × 17-19	机针	NEEDLE	1
5	S100914	针板座 (φ2.2)	NEEDLE HOLE GUIDE	1
6	D280517	梭床盖C	INNER HOOK PRESSER ASM.	1
	Y01.08-24	梭床销	GUIDE PIN	2
7	D1828-282-N00	摆梭	INNER HOOK	1
8	E380204	挑线弹簧	THREAD TAKE-UP SPRING	1
9	E380205	夹线压簧	THREAD TENSION SPRING	1
10	D2811330	左压脚组件(No.6)	WORK CLAMP FOOT, LEFT NO.6	1
11	D2811320	右压脚组件(No.6)	WORK CLAMP FOOT, RIGHT NO.6	1
12	D281139	进给板	FEED PLATE	1
13	D281142	安全框	FINGER GUARD	1

20. GD22308D-T02 伞顶圆型电脑加固机

GD22308D-T02 ELECTRONIC BARTACKING MACHINE FOR UMBRELLA TOP (CIRCULAR PATTERN)

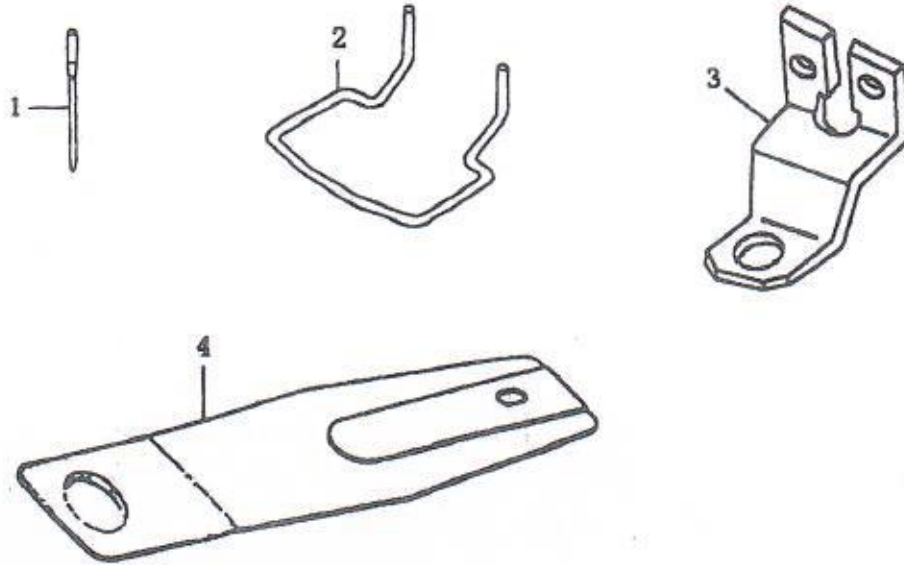

专用花样: 51# 专用花样: 52# 专用花样: 53#



29针



52针



76针

缝纫范围: $\phi 12$

缝纫范围: $\phi 12$

缝纫范围: $\phi 12$

序号	图号	零件名称	Description	数量
1	DP × 5-12	机针	NEEDEL	1
2	D281142	安全框	FINGER GUARD	1
3	D8.24-2.1	圆样压脚组件	WORK CLAMP FOOT (CYCLE STYLE)	1
4	D8.24-1	进给板	FEED PLATE	1

21. GD22308D-T03 方结型电脑加固机

GD22308D-T03 ELECTRONIC BARTACKING MACHINE
(SQUARE PATTERN)

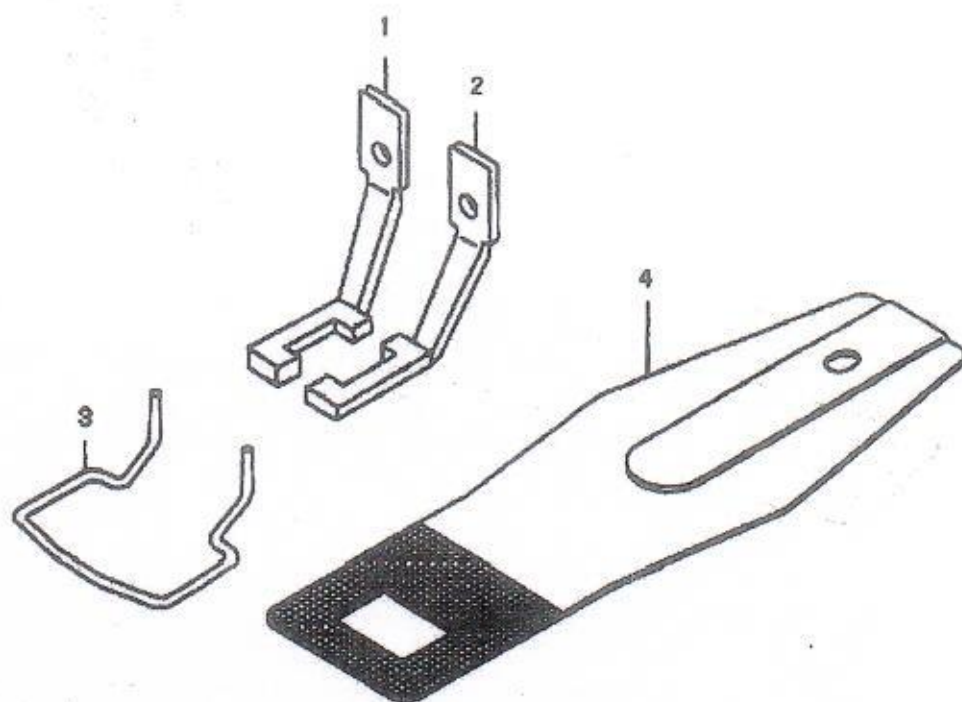

专用花样: 59#

63针

缝纫范围: 12 × 10



序号	图号	零件名称	Description	数量
1	D281144	左压脚	WORK CLAMP FOOT, LEFT	1
2	D281143	右压脚	WORK CLAMP FOOT, RIGHT	1
3	D281142	安全框	FINGER GUARD	1
4	D281145	进给板	FEED PLATE	1

22. GD22308D-T04 装饰钮孔型电脑加固机

GD22308D-T04 ELECTRONIC BARTACKING MACHINE
(DECORATIVE PATTERN)

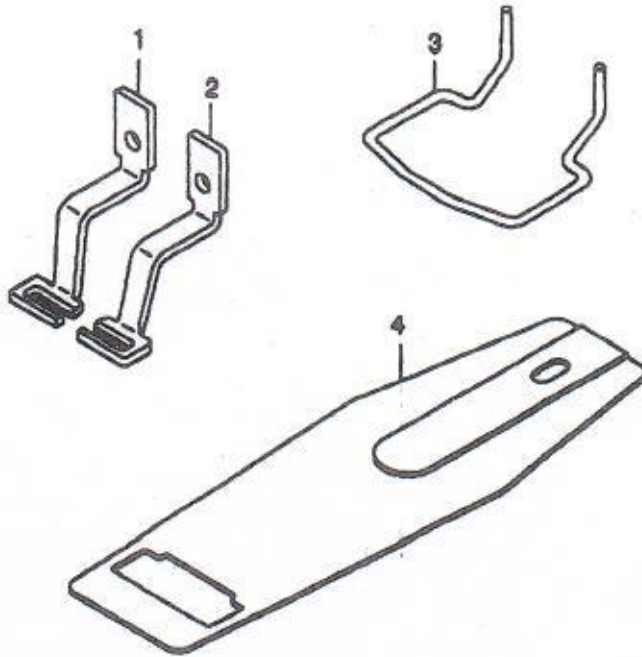





专用花样: 40#	专用花样: 41#
102针	120针
缝纫范围: 4 × 25	缝纫范围: 4 × 25

序号	图号	零件名称	Description	数量
1	D281107	左压脚B	WORK CLAMP FOOT B, LEFT	1
2	D281106	右压脚B	WORK CLAMP FOOT B, RIGHT	1
3	D281128	安全框	FINGER GUARD	1
4	D281111	进给板B	FEED PLATE B	1

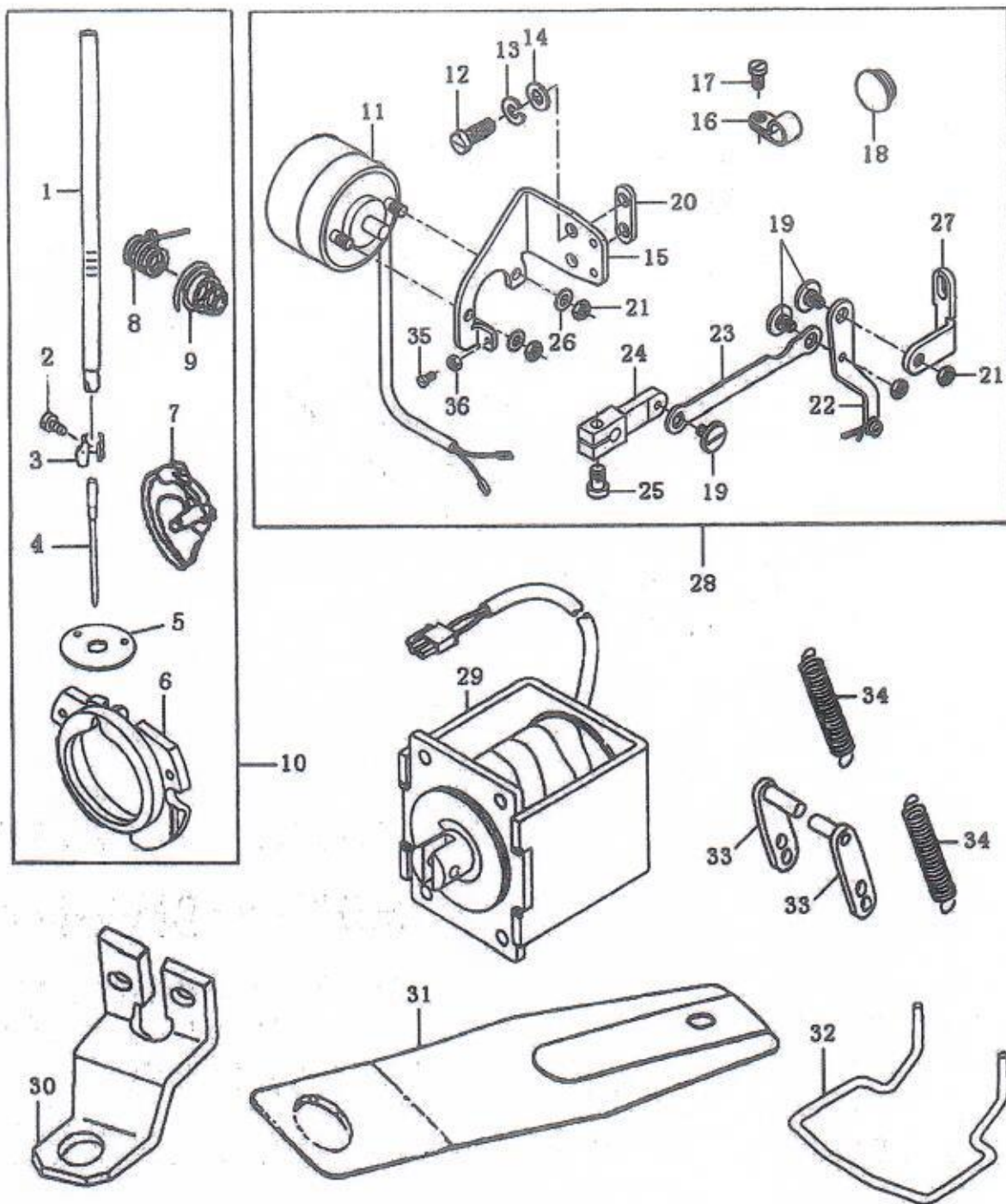
23. GD22308D-T05 膨垫圆型电脑加固机

GD22308D-T05 ELECTRONIC BARTCKING MACHINE FOR ELASTRIC MATS (CIR CULAR PATTERN)



专用花样: P1#	专用花样: P2#	专用花样: P3#
 29针	 52针	 76针
缝纫范围: $\phi 15$	缝纫范围: $\phi 15$	缝纫范围: $\phi 15$

序号	图号	零件名称	Description	数量
1	E380206	针杆	NEEDLE BAR	1
2	FJ65	螺钉SM1/8×44×4.5(5×1.5)	SCREW 1/8×44×4.5(5×1.5)	1
3	E380207	过线板	THREAD GUIDE	1
4	DP×17-19	机针	NEEDLE	1
5	5100914	针板座(φ2.2)	NEEDLE HOLE GUIDE	1
6	D280517	梭床盖C	INNER HOOK PRESSER ASM.	1
7	Y01.08-24	梭床销	GUIDE PIN	2
8	D1828-282-N00	摆梭	INNER HOOK	1
9	E380204	挑线弹簧	THEARD TAKE-UP SPRING	1
9	E380205	夹线压簧	THEARD TENTION SPRING	1
10		厚料机专用部件		1
11	5300106	拨线电磁铁组件	SOLENOID RELAY CABLE ASM.	1
12	FJ67	螺钉SM11/64×40×14(7×2.8)	SCREW 11/64 L=14	2
13	GB859	垫圈4	SPRING WASHER 4	2
14	GB97.1-85	垫圈4	WASHER 4	2
15	5310305	拨线电磁铁座	SOLENOID PITTING PLATE	1
16	DGJ-2	电线固定扣	CABLE CLIP	3
17	FJ67	螺钉SM11/64×40×7(7×2.5)	SCREW 11/64-40 L=7	3
18	F80120	橡胶堵	RUBBER PLUG	1
19	5310302	铰接螺钉	HINGE SCREW	3
20	E380107	垫片	WASHER	1
21	GB6172.1	薄螺母 M4	NUT M4	4
22	53103010	拨线杆组件	WIPER	1
23	5310303	拨线连杆	WIPER LINK	1
24	5310304	拨线摆杆	WIPER ARM	1
25	GB5783	螺栓 M4×12	SCREW M4 L=12	1
26	GB93-87	垫圈4	WASHER 4	2
27	5100602B	拨线杆座	WIPER BASE PLATE	1
28		电子拨线器部件		1
29	D2804110-T	升压脚电磁铁	PRESSER LIFTING SOLENOID ASM.	1
30	D2811470	圆样压脚组件	WORK CLAMP FOOT ASM.	1
31	D281148	圆样进给板	FEED PLATE (CYCLE STYLE)	1
32	D281142	安全框	FINGER GUARD	1
33	D2811530	驱动板组件	LEVER DRIVING PLATE ASM.	1
34	D281152	压脚弹簧	CLOTH PRESSER SPRING	1
35	GB67	螺钉 M3×12	SCREW M3 L=12	1
36	GB6170	螺母 M3	NUT M3	1

24. GD22308D-T06 菊花眼结型电脑加固机

GD22308D-T06 ELECTRONIC BARTACKING MACHINE FOR STITCHED EYELETS

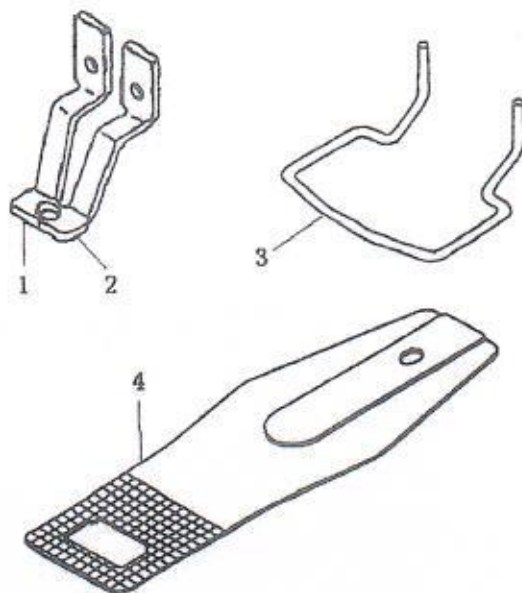

专用花样: 32# 99针 缝纫范围: $\phi 3 \times \phi 9$	专用花样: 33# 110针 缝纫范围: $\phi 2 \times \phi 8$	专用花样: 31# 90针 缝纫范围: $\phi 2 \times \phi 8$	专用花样: 35# 130针 缝纫范围: $\phi 2 \times \phi 8$
--	---	--	---

序号	图号	零件名称	Description	数量
1	D281150	左压脚 (鸡眼结)	WORK CLAMP FOOT, LEFT	1
2	D281149	右压脚 (鸡眼结)	WORK CLAMP FOOT, RIGHT	1
3	D281114	安全框 C	FINGER GUARD C	1
4	D281151	进给板	FEED PLATE	1

25. GD22308D-T07 安全带型电脑加固机

GD22308D-T07 ELECTRONIC BARTACKING MACHINE FOR SAFETY BELTS

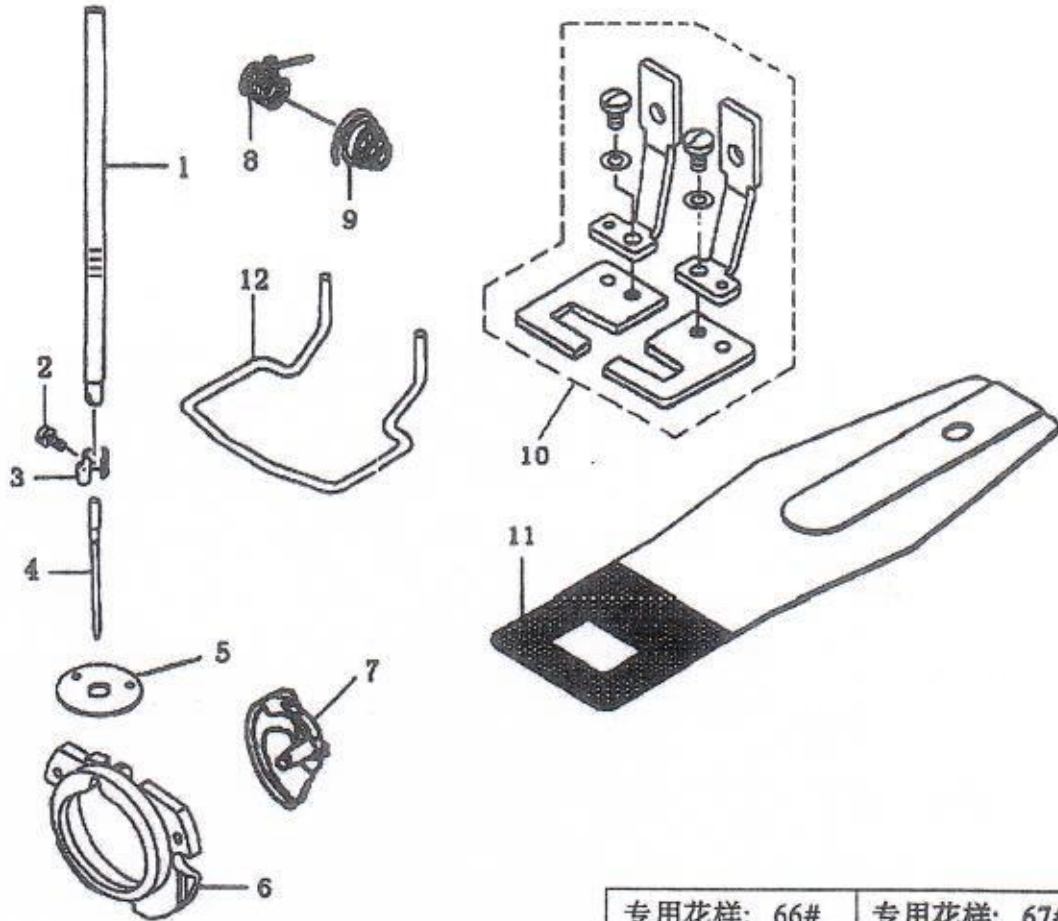

专用花样: 66#

专用花样: 67#

54针

68针

缝纫范围: 30 × 4

缝纫范围: 40 × 4

序号	图号	零件名称	Description	数量
1	E380206	针杆	NEEDLE BAR	1
2	FJ65	螺钉SM1/8 × 44 × 4.5(5 × 1.5)	SCREW 1/8 × 44 × 4.5(5 × 1.5)	1
3	E380207	过线板	THREAD GUIDE	1
4	DP × 17-19	机针	NEEDLE	1
5	5100914	针板座(Φ2.2)	NEEDLE HOLE GUIDE	1
6	D280517	梭床盖C	INNER HOOK PRESSER ASM.	1
	Y01.08-24	梭床销	GUIDE PIN	2
7	D1828-282-N00	摆梭	INNER HOOK	1
8	E380204	挑线弹簧	THEARD TAKE-UP SPRING	1
9	E380205	夹线压簧	THEARD TENTION SPRING	1
10	51011370	(40 × 5)快换压脚组件	WORK CLAMP FOOT ASM.(40 × 5)	1
11	5101138	进给板(40 × 5)	FEED PLATE(40 × 5)	1
12	D281142	安全框	FINGER GUARD	1

4. SHUTTLE DRIVER SHAFT COMPONENTS

下軸関係

BT 2900 LCH.

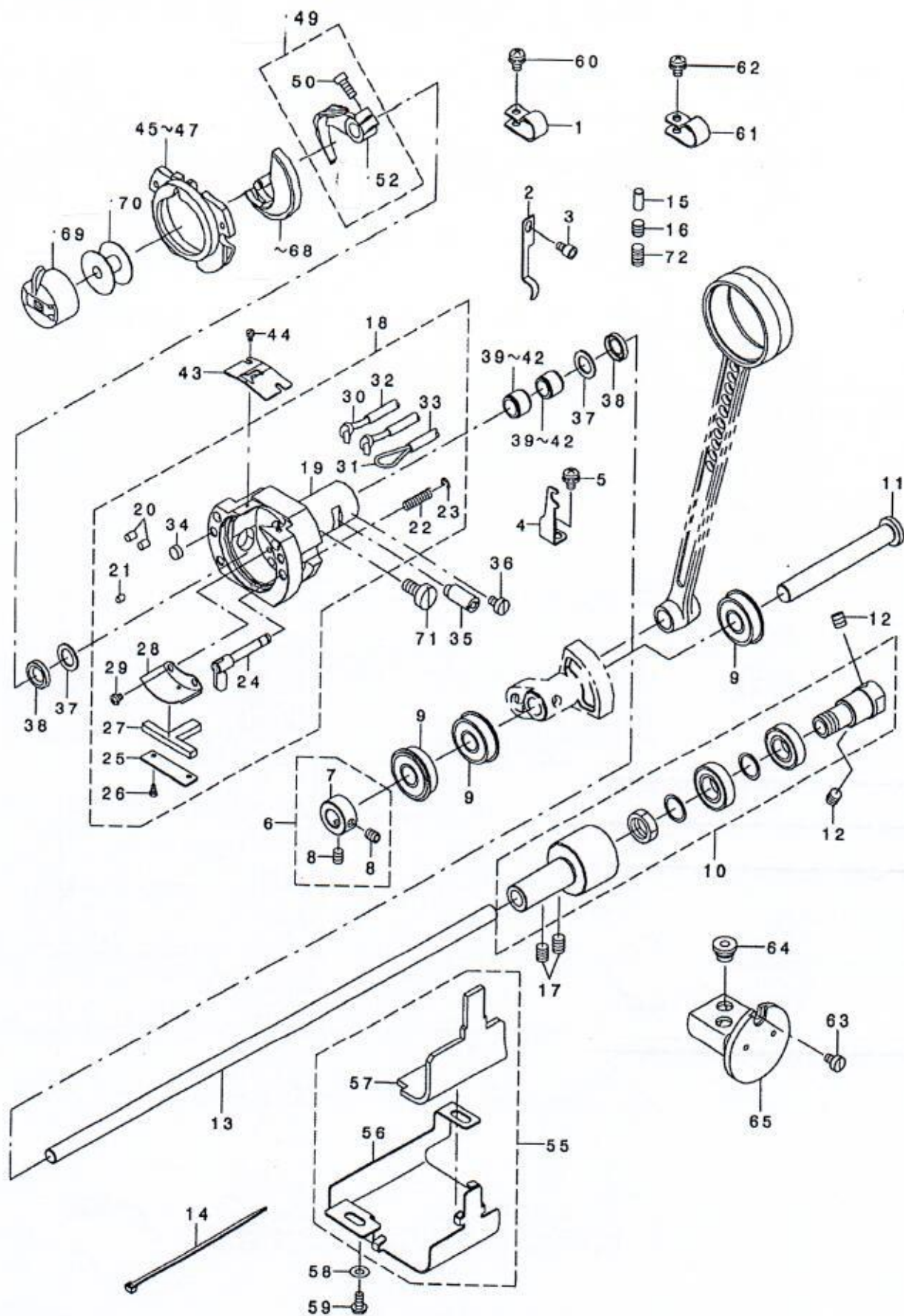

REF. NO	NOTE	PART NO.	DESCRIPTION	Qty
1		HX-0015000-0D	CABLE CLIP	1
2		400-12127	OIL PIPE HOLDER	1
3		SM-6040602-TP	SCREW M4 L=6	1
4		400-13721	TUBE CLAMP	1
5		SL-4040891-SC	SCREW M4 L=8	1
6		400-10484	THRUST COLLAR ASM.	1
7		400-10467	THRUST COLLAR	1
8		400-10469	THRUST COLLAR SCREW	(1)
9		SB-1100024-00	BEARING	(2)
10		400-16077	LOWER SHAFT GEAR ASM.	3
11		400-06563	OSCILLATOR SHAFT	1
12		SM-8060612-TP	SCREW M6 L=6	1
13		400-10676	LOWER SHAFT	2
14		EA-9500801-00	CABLE BAND	1
15		400-06578	OIL WICK PRESSER	2
16		SM-8060610-TP	SCREW	1
17		SM-8060812-TP	SCREW M6 L=8	1
18		400-06573	SHUTTLE ASM.	2
19		400-06574	SHUTTLE	1
20		B1820-210-D00	SHUTTLE OIL FELT A	(1)
21		B1821-210-D00	SHUTTLE OIL FELT B	(2)
22		B1822-215-P00	INNER HOOK PRESSER SPRING	(1)
23		RE-0300000-K0	E-RING 3	(2)
24		265-01858	INNER-HOOK-PRESSER ASM.	(2)
25		141-04004	ONCE THROUGH OIL FELT PRESSER	(1)
26		SM-6020460-TP	SCREW M2 L=3.5	(1)
27		141-03907	SHUTTLE ONCE THROUGH OIL FELT	(2)
28		400-06577	SHUTTLE LUBRICATING PLATE	(1)
29		SM-4030455-SP	SCREW	(1)
30		CQ-2000000-00	OIL WICK	(2)
31		CQ-2000000-00	OIL WICK	(2.6)
32		236-30007	TUBE	(1.4)
33		236-30007	TUBE	(1)
34		135-29607	SHUTTLE PACKING	(0.6)
35		400-10471	SHUTTLE RACE ADJUSTING SHAFT	(2)
36		SM-6040650-TP	SCREW M4 L=6	1
37		400-06575	SHUTTLE BEARING RING	1
38		400-06576	SHUTTLE OIL SEAL	2
39	01	SB-3080010-0A	BEARING	2
40	01	SB-3080010-0B	BEARING	2
41	01	SB-3080010-0C	BEARING	2
42	01	SB-3080010-0D	BEARING	2
43		B1815-210-000	INNER HOOK UPPER SPRING	1
44		SM-6020460-TP	SCREW M2 L=3.5	1
45	02	141-03253	INNER HOOK PRESSER ASM., A	2
46	03	141-03352	INNER HOOK PRESSER ASM., B	1
47	06	141-03659	SHUTTLE RACE RING ASM., C	1
48	08	400-11612	DRIVER ASM.	1
49	07	400-14963	SHUTTLE DRIVER ASM.	1
50		SS-6121212-TP	SCREW 3/16-28 L=12.0	1
51	08	400-11611	SHUTTLE DRIVER	(1)
52	07	400-10879	SHUTTLE DRIVER	(1)
53	08	B1828-210-000	BOBBIN CASE ASM. (RAGING PREVE)	(1)
54	08	138-12192	BOBBIN	1
55		400-10473	LOWER SHAFT GEAR COVER ASM.	1
56		400-10474	LOWER SHAFT GEAR COVER	(1)
57		400-10475	LOWER SHAFT GEAR FELT	(1)
58		WP-0450801-SP	WASHER	2
59		SM-5040855-SM	SCREW	2
60		SL-4040891-SC	SCREW M4 L=8	2
61		HX-0015000-0B	CABLE CLIP	1
62		SL-4040891-SC	SCREW M4 L=8	2
63		SM-6040650-TP	SCREW M4 L=6	2
64		400-06840	RUBBER BUSH	1
65		400-06836	OIL TANK ASM.	2
66	05	400-06680	SHUTTLE	1
67	04	400-06681	SHUTTLE (H)	1
68	07	400-14965	SHUTTLE (H)	1
69	07	B1828-210-DAA	BOBBIN CASE ASM.	1
70	07	B1806-210-D00	BOBBIN	1
71		400-10470	SHUTTLE ASM SCREW	1
72	*	SM-8061050-TP	SCREW	1

NOTE (注記)

- 01... SELECTIVE PARTS
- 02... FOR LK-1900AF, AM
- 03... FOR LK-1900AS
- 04... FOR LK-1900AH
- 05... EXCEPT LK-1900AH, AW
- 06... FOR LK-1900AH, AW
- 07... FOR LK-1900AW
- 08... EXCEPT LK-1900AW

- 選択部品
- LK-1900AF, AM用
- LK-1900AS用
- LK-1900AH用
- LK-1900AH, AMを除く
- LK-1900AH, AW用
- LK-1900AW用
- LK-1900AWを除く

Global BT 2900 H

1. MAXCG-HN-1 Shuttle Driver. = SH181
2. MAGCG-ST-2 Shuttle.
3. MAXCG-BC-3 Bobbin Case. — SC181
4. MAXCG-BN-4 Bobbin.

PLEASE NOTE

Part numbers are for large capacity bobbin.

