

BREAKDOWN DRAWING

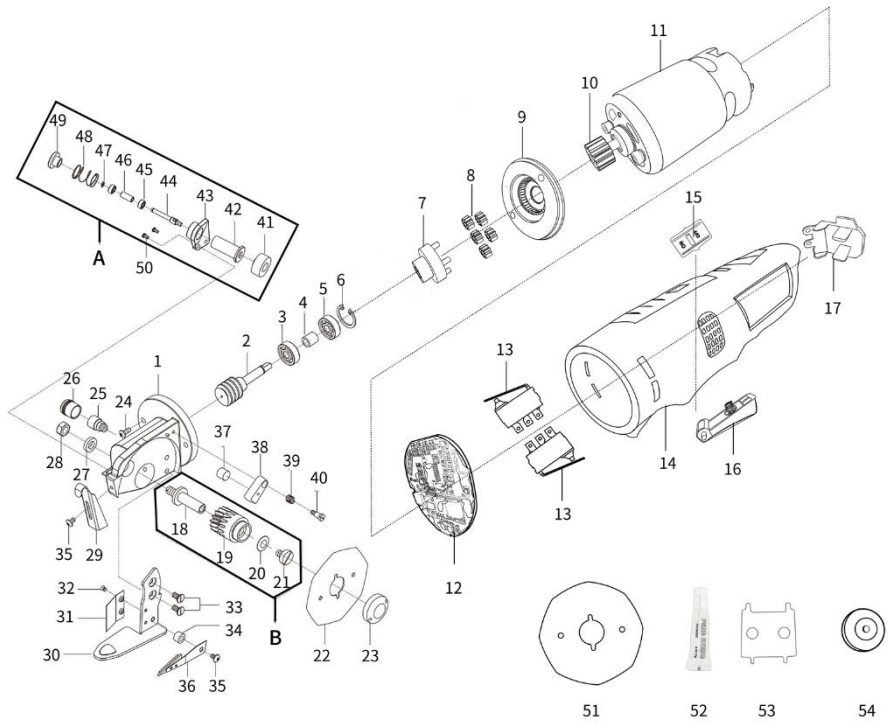

Ref.no.	Description	Ref.no.	Description	Ref.no.	Description	Ref.no.	Description
1	Gear Housing	17	Power Socket	33	Standard Screw	49	Grinder Button
2	Drive Gear	18	Worm Wheel Shaft	34	Collar	50	Standard Screw
3	Bearing	19	Worm Wheel	35	Standard Screw	51	Blade
4	Collar	20	Brass Washer	36	Lower Knife	52	Grease Oil
5	Bearing	21	Screw	37	Oil Felt	53	Spanner
6	Shaft Ring	22	Blade	38	Knife Oiler	54	Grinder Wheel
7	Planet Carrier	23	Blade Nut	39	Spring For Oiler	A	Grinding Wheel set
8	Planetary Tooth	24	Standard Screw	40	Screw For Oiler	B	Worm Wheel
9	Outer Gear ring	25	Oil Cup	41	Grinder Wheel		
10	Sun Gear	26	Oil Cup Cover	42	Grinder Wheel Shaft		
11	Motor	27	Washer	43	Grinder Wheel Shaft		
12	Line Protection Board	28	Nut	44	Grinder Shaft		
13	Switch	29	Safe Guard	45	Bearing		
14	Body Shell	30	Press Foot	46	Collar		
15	Power Switch	31	Guide Plate	47	Shaft Ring		
16	Start Switch	32	Standard Screw	48	Sping		

# INSTRUCTIONS

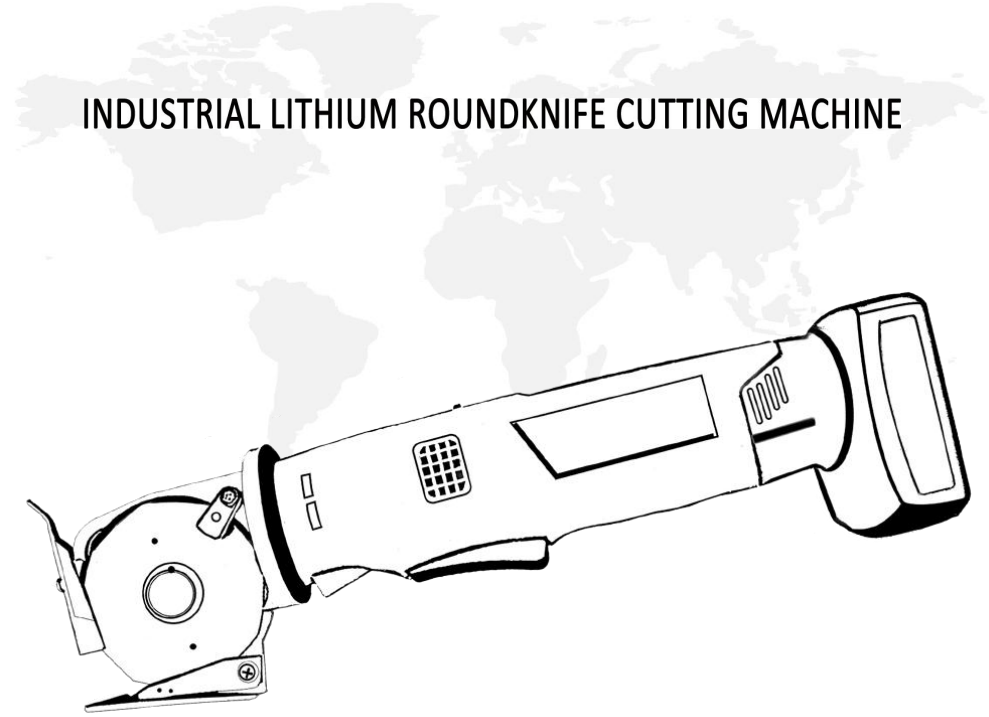

## RB-70

## Technical data

Model	RB-70
No-load speed	1000r/min
Blade diameter	70mm
Cutting thickness	≤25mm
Rated voltage	DC 10. 8V
Charger input voltage	AC 110-240v 50-60Hz
Standard battery pack(capacity)	2Ah、 4.0Ah
Net weight	989g、 1207g

The manufacturer reserves the right to change the specifications without prior notice.

Specifications and battery packs may vary by country.

Weight varies depending on accessories (including battery pack).

## Main Application

The cutting machine is suitable for cutting flexible soft materials up to 35mm thick, such as leather, carpet, cloth, cardboard and similar materials.

## Safety Warning

Please read through all safety warnings, instructions And Specifications attached to this power tool.

Work area safety matters:

1. Keep the work area clean with good lighting condition. Chaotic or dark work areas are prone to unexpected situations.
2. Do not operate the power tool in an explosive environment such as a flammable liquid, gas or dust. The spark generated by the power tool may ignite dust or gas.

## Use and maintenance

1. Please use the charger specified by the Manufacturer for charging. Charging with a charger that is not suitable for the battery may cause a fire.
2. Only special batteries can be used for power tools. Using other types of batteries may result in personal injury or fire.
3. Keep it away from small metal objects when not using the battery. These objects may short out the battery terminals and cause a fire.
4. Do not use damaged or modified batteries or tools.
5. Damaged or modified batteries can present unpredictable results, such as fire and explosion.
6. Please follow all charging instructions.

## Battery Precautions

1. Please read through all instructions carefully before using the battery.
2. Do not disassemble the battery.
3. If the electrolyte gets into your eyes, rinse with clean water and seek medical attention immediately, otherwise your vision may be impaired.
4. Do not short the battery: Do not allow any conductive material to touch the terminals; Do not place the battery in the same container as other metal objects; Do not place the battery in water or rain.
5. Do not place tools and batteries in high temperature places.
6. Do not incinerate or hit the battery.
7. Do not use a damaged battery.
8. The lithium ion battery included with this tool meets the requirements of dangerous goods.
9. Please follow local regulations on how to dispose of used batteries. Dispose of used batteries.

⚠ Warning: Please use original battery.

Tips for maintaining maximum battery life

1. Charge in time before the battery is completely drained. When the tool is in low power, stop operating the tool and charge the battery.
2. Do not recharge a fully charged battery. Overcharging will shorten the battery life.
3. Please charge the battery under normal temperature conditions. Please charge after the hot battery is cooled.

## Direction for use

### 1. Lithium ion battery

When removing the battery, press the buttons on both sides of the battery while pulling the battery out of the tool.

Always turn off the power and remove the battery before adjusting or checking the machine functions. When installing the battery, align the battery in the front-rear direction with the groove on the cover, then push it into place until the battery is locked and clicks.

This unit is equipped with a battery protection system. The system automatically cuts off power to extend battery life.

During operation, the tool may stop running when the battery is overheated or the battery power is too low. In this case, the battery should be cooled and charged in time.

### 2. sharpen

When using the new machine, first start the machine, and when the blade rotates, press the sharpening button down to sharpen the knife for 10 seconds to make the blade sharper!

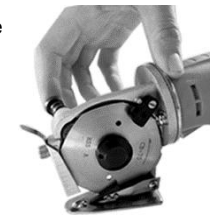

### 3. Fuel filler (oil cup)

Regularly add grease to the turbine from the Fuel filler to increase the service life!



### 4. Safety switch and start-stop switch

When the safety switch is in the OFF state, do not trigger the start/stop switch, otherwise it may be damaged. To start the unit, first turn the safety switch to ON, then press the start and stop switch to start the machine. Always stop the safety switch when you stop working!

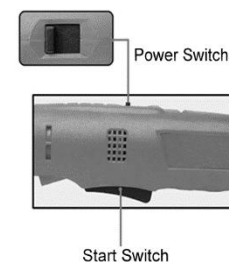

### 5. Replace the blade

Remove the blade cap and blade with the original special wrench. Tighten the blade cap to secure the blade with a wrench, make sure the surface with words upside to make the blade flat.

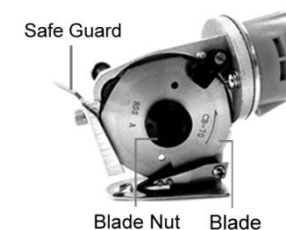

### 6. blade safe guard

The knife guard prevents the blade from injuring people and the height can be adjusted freely.

### 7. blade

The blade is sharp, and it is strictly forbidden to touch the blade during machine work!

## Maintenance service

1. Please hand over the power tool to a professional service person to ensure the safety of the tool.
2. Never repair a damaged battery pack.
3. Lubricate and replace accessories as instructed.
4. Keep the handle dry, clean, free of oil.
5. Wear gloves when replacing the blade.
6. Always turn off the power or remove the battery before making any adjustments, replacing accessories, or storing power tools.