

HD40-3 USER MANUAL



CONTENTS

1. Safety Precaution
2. Installation
3. Panel Key Functions
4. Adjust step at parameter zone
5. General Parameter List



H. S. Global Service Network
 SERVICE HOTLINE : +886-2-2676-5203
 FAX : +886-2-2689-6600, 2689-3657
 E-MAIL: service@hohsing.com.tw
 WEBSITE: http://www.hohsing.com

China Region
 SERVICE HOTLINE : +86-21-64901024
 FAX : +86-21-54570064
 WEBSITE : http://www.hohsing.com



EC Declaration of Conformity

We hereby declare that the following products:
 AC servo motor—HD series
 are in conformity with the provision of the EC directives as following:
 -EC Low Voltage Directive (2014/35/EU)
 -EC Electromagnetic Compatibility Directive (2014/30/EU)
 -EC Machinery Directive (2006/42/EC)

Applied harmonized standards:
 EN 60204-31 : Electrical equipment of industrial machines,
 Particular requirements for sewing machines,
 sewing units and sewing system.
 EN 12100 : Safety of machines.

Declaration of Conformity for Concentration Limits for Certain Hazardous Substances

We hereby declare that the following products:
 AC servo motor—HD series
 are in conformity with the following directives and requirements:
 1. European Union RoHS Directive (2002/95/EC) and the concentration limits for certain hazardous substances (2005/618/EC)
 2. People's Republic of China Electronic Business Standard : Requirements for concentration limits for certain hazardous substances in electronic information products (SJ/T 11363-2006)

Hazardous Substance	Permissible Values
Lead (Pb)	Less than 240 ppm
Mercury (Hg)	Less than 800 ppm
Cadmium (Cd)	Less than 80 ppm
Hexavalent chromium (Cr VI)	Less than 800 ppm
Polybrominated Biphenyl (PBB)	Less than 800 ppm
Polybrominated Diphenyl ether (PBDE)	Less than 800 ppm

*The concentration of lead in the lead-free process for PCB shall be less than 800 ppm.
 *For packing materials shipped with our products or parts, the hazardous substances shall be 80 ppm or less in sum of Pb+Hg+Cr+VI.

H. S. Machinery. Co., Ltd.

Mr. C. C. Lee
 Plant Manager

1. Safety Precaution :

Please read this manual with sewing machine manual thoroughly and pay attention for the following safety precaution.

- Installation and operation must be done by the trained personnel, also turn off the power switch and remove the plug from outlet and wait for 5 minutes before any installation.
- This product is designed for the specific sewing machines and must not be used for other purposes.
- Only use the power voltage as described on the name plate of the motor and control box in ±10 % ranges.

Attention : If the control box is AC 220V system, please don't connect to the AC 380V power outlet, otherwise the error will occur and motor is not functional. If that happened, please turn off the power switch immediately and check the power voltage. Continue supply the 380V power over 5 minutes might damage the fuses and burst the electrolytic capacitors and even might endanger the person safety.

- In order to prevent abnormal operation, keep the product away from the high frequency machines.
- Don't operate in direct sun light - outdoors area and the room temperature is 45°C above or 5°C under.
- Don't operate near the heater - dew area and the humidity is 30 % less or 95% more.
- Don't operate in dusty - evaporate - combustible gas area, and stay away from corrosive material.
- Don't apply heavy objects or excessive force on the power cord, also don't bend or pull the power cord.
- In order to prevent the static interference and current leakage, all grounding works must be done properly.
- After power on the machine for the first time, use low speed to operate and check the correct rotation direction.
- During machine operation, don't touch any moving parts.
- All moving parts must have protective device to avoid the body contact and objects insertion.
- Maintenance and repair must be done by the properly trained technician, also all the spare parts for repair must be approved or supplied by the manufacturer.
- Don't use any objects or force to hit or ram the product.

Danger and caution signs

Risks that may cause personal injury or risk to the machine are marked with this symbol in the instruction manual.

This symbol indicates electrical risks and warnings.

Limited Warranty

Warranty period of this product is 1 year from purchasing, or 18 months from our manufacturing date.

Warranty Detail

Any trouble found within warranty period under normal use condition in conformance with this manual, it will be repaired free of charge. Repair will be chargeable in the following cases even if within warranty period:

1. Inappropriate use include: wrong connecting high voltage, wrong application, disassemble, repair, modification by incompetent personnel, or operate the product without the precaution, or operate the products out of its specification range. Insert odd objects or liquids into the product.
2. Damage by fire, Earth quake, lightning, wind, flood, salt corrosive, moisture, abnormal power voltage and any other damage cause by the natural disaster or by the inappropriate environments.
3. Dropping after purchase, or damage in transportation by customer himself. (or by customer's shipping agency)

Note : We put our best effort and mind in testing and manufacturing for assuring the quality and reliable of this product. But it is possible this product can still be damaged due to external magnetic interference and electronic static or noise or unstable power source more than expected; therefore the grounding system of operate area must be well-connected to this product and it's also recommended to install a failsafe device, (such as residual current breaker).

2. Installation:

HD installation

Mounts speed control unit and control box

under the sewing machine table.

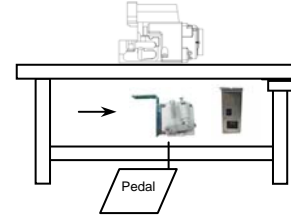

Caution :
 For person safety, turn off the power switch and remove the power plug from outlet before any adjustment.

Motor Installation

PEGASUS MX/EX/M900/M800 Overlock Mode:

1. Take off the pulley of sewing machine, remain the exhaust fan.
2. Put washer into the shaft of sewing machine then put it in the shaft of motor, to use screw to screw tight the shaft of the motor.

Note: The red mark on motor to fix on the shaft of sewing machine by set screw.

Plases change set screw on red dot to flat head set screw if installs EX machine.

Plases insert shaft washer priority and uses screw to tight up the washer then assemble the shaft while installs M900 M800 machine.

3. Put a fixture to motor then set into motor shaft, push motor to sewing machine end face by a fixture.

Note: Motor shaft sticking strong magnet, plases pay attention to powerful magnetic while force motor to sewing machine to avoid damage the motor or hurt your finger. Plases throw away the assemble tooling after assembled one machine. It is prohibit to use assemble tooling repeat.

4. Put motor pulley to motor shaft then tighten the screw. Note : Plases turn the sewing machine to up position before tighten the pulley and fix the set screw on the pulley. After that the needle at up position while motor is stop running. Plases release the pulley to process micro adjustment on pulley if the needle stop position is not satisfied.

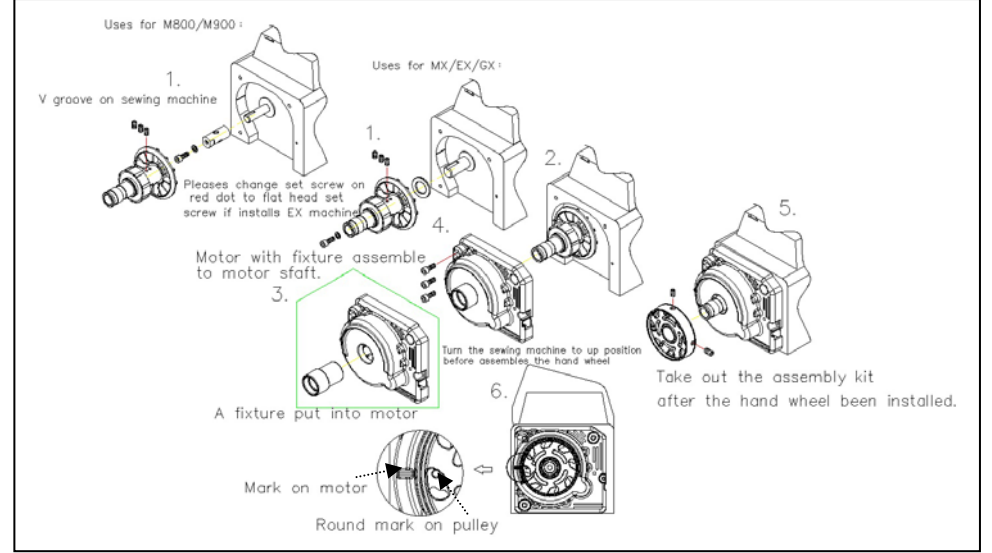

Speed Control Unit adjustment

	Term of adjustment	Adjustment result
1	Toeing forward force adjustment	Spring A move to right = force increased Spring A move to left = force decreased
	Heeling backward force adjustment	Bolt B turn ↺ = force decreased Bolt B turn ↻ = force increased
3	Pedal stroke adjustment	Rod D secure at right = stroke is longer Rod D secure at left = stroke is shorter

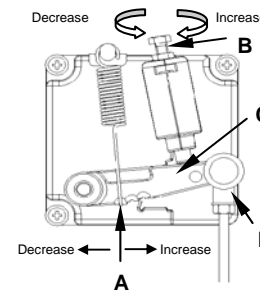

Caution :
 For person safety, turn off the power switch and remove the power plug from outlet before any adjustment.

Components of speed control unit : see figure

- A: Spring for toeing forward force adjustment
- B: Bolt for heeling backward force adjustment
- C: Pedal arm
- D: Pitman rod for pedal

3. Panel Key Functions :

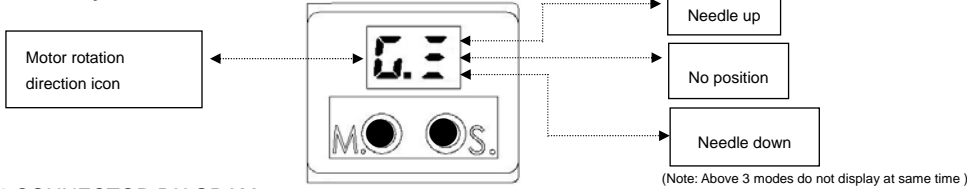

3.1 CONNECTOR DIAGRAM:

HD40-3

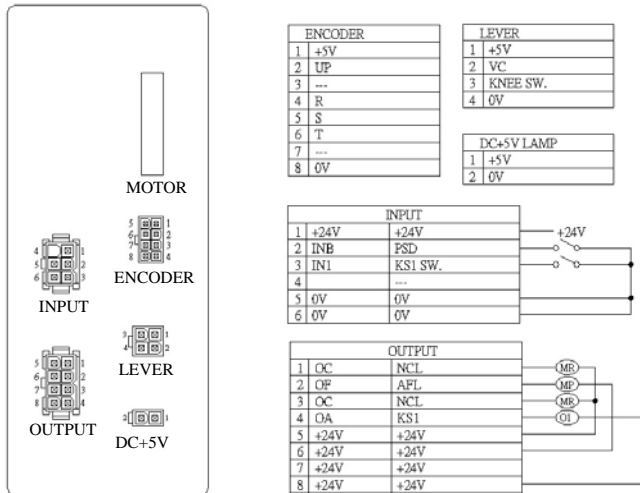

4. Adjust step at parameter zone:

- Step1: Press "M." key to enter setting mode.
- Step2: Press "M." key select the parameter you want to adjust.
- Step3: Press "S." key enter the parameter value adjustment.
- Step4: Press "M." key increase the value.
- Step5: Press "SET" key to save.

4.1 How to set needle position while fixed the synchronizer :

Press the " S. " key. Enter the setting mode , press " M. " key To select UP / DOWN , press " S. " key to save.

5. General Parameter List :

Parameter NO.	Function Name	Range	Ratio	D0	D1	D2
				Overlock	Overlock /TK	Overlock /ASL
P0	H	Maximum sewing speed	P1(L)-7500 spm	*100	50	50
P1	L	Low speed	300-500/P0(H) spm	*10	30	30
P2	SP	Sewing speed	Zero speed-Hi speed	*100	0	0
P3	SIN	Single positioning signal synchronizer	0/2	*1	0	0
P4	NU	Define the UP positioning signal mode H/L	L/H	---	L	L
P6	POL	Slow start setting for fist stitch sewing when the power ON	ON/OFF	---	OF	OF
P7	SLM	Slow start operation mode	T/A/OFF	---	OF	OF
P8	S	Slow start speed	300-2000 spm	*100	4	4
P9	SLS	Stitch numbers for slow start	1-99 stitches	*1	2	2
PA	DIR	Direction of motor rotation	CC/CW	---	CC	CC
PB	SVC	Pedal start stroke position adjustment	0-9	*1	0	0

Parameter NO.	Function Name	Range	Ratio	D0	D1	D2
				Overlock	Overlock /TK	Overlock /ASL
PC	TVC	Pedal trimming stroke position adjustment	0-9	*1	0	0
PD	HHC	Cancel foot lifting at half-heeling pedal	ON/OFF	---	OF	OF
PE	FHC	Cancel trimming at full-heeling pedal	ON/OFF	---	OF	OF
PZ	MAC	Machine code	D0-D2	---	D0	D1
FL	FLOAD	Factory default load	Y/N	---	N	N
FS	FSAVE	Factory default save	Y/N	---	N	N
BS	ASLB	Front suction function selection	ON/OFF	---	OF	ON
C1	ASLC1	Front suction stitches setting	0-99 stitches	*1	10	10
ES	ASLE	Rear suction function selection	ON/OFF	---	OF	ON
C2	ASLC2	Rear suction stitches setting	0-99 stitches	*1	35	35
DS	BDS	Setting stitches of delay rear suction	0-20 stitches	*1	0	0
BT	TCB	Front cutter function selection	ON/OFF	---	OF	ON
C3	TCS1	Setting stitches of front cutter	0-99 stitches	*1	8	8
ET	TCE	Rear cutter function selection	ON/OFF	---	OF	ON
C4	TCS2	Setting stitches of rear cutter	0-99 stitches	*1	35	35
WS	WSUCM	Air saving function selection	ON/OFF	---	ON	ON
W1	WSUC1	Setting valid stitches of suction for air saving	0-99 stitches	*1	10	10
W2	WSUC2	Setting invalid stitches of suction for air saving	0-990 stitches	*10	3	3
C8	SEN	Edge sensor function selection	ON/OFF	---	OF	ON
C9	AS	Automatic sewing speed	200-5000 spm	*100	20	20
CA	PSN	Re-start function at emergency stop	ON/OFF	---	OF	OF
CB	IBV	PSN logic signal invert	ON/OFF	---	OF	OF
CC	CMS	Edge sensor signal check	0-99 stitches	*1	3	3
CD	AFL	After real section auto foot lifting mode selection	0-3	*1	0	0
CE	TFM	When sensor detect the fabric, full heeling pedal mode selection	0-2	*1	0	0
CF	NIKT	Tape cutter link air saving off delay time	0-990 ms	*10	25	25
CG	SET	Trimming mode at sensor stop	ON/OFF	---	ON	ON
CH	SME	Mode selection for [C2. ASLC2] Stitches sewing	A/M	---	M	M
CI	MTC	Define the fabric protection function, when sensor detect the fabric	ON/OFF	---	OF	OF
CJ	STP	Restart section function select	ON/OFF	---	OF	ON
CK	TK3	Tape cutter action time	10-990 ms	*10	10	10
CL	AFT	The edge sensor command foot lifting turn off time	10-990 ms	*10	20	20
Power On + S Key	I1	IN1	IN1 Input function select	NO/TK/OP	---	TK
	IB	INB	INB Input function select	NO/PT/SO/SC	---	NO
	IF	INF	INF Input function select	NO/F/TK	---	F
	OA	OA	OA Output function select	NO/TK/AS/OP/OM	---	TK
	OC	OC	OC Output function select	NO/NC/NW/AS/AW	---	NC

NOTE:

Selected machine code Enter "PZ" PARAMETER , press S . KEY and hold it to adjust digit 0-9.

Violators will be prosecuted