

GLOBAL

LPZ 9910 DD Series

Postbed zig-zag Direct drive machines

**Instruction manual
& Spare parts**

**Always switch off the electricity when working on
the machine.**

使用说明书/ Operation Manual

缝纫机规格/Sewing machine specification	1-2
1 机针和线/ NEEDLE AND THREAD	3
2 安装膝控抬压脚/ INSTALLING THE KNEE LIFTER	4
3 润滑油/ LUBRICATION	4
4 润滑油条件/ LUBRICATION CONDITION	5
5 机针的安装/ HOW TO INSTALL THE NEEDLE	5
6 旋梭的安装/ HOW TO INSTALL THE BOBBIN	6
7 机器穿线/ HOW TO THREAD THE MACHINE HEAD	7
8 调整缝制长度/ ADJUSTING THE STITCH LENGTH	8
9 调节压脚压力/ ADJUSTING THE PRESSER FOOT PRESSURE	8
10 线张力调节/ THREAD TENSION	9
11 缝目宽度调节器/ STITCH WIDTH REGULATOR	9
12 如何控制人字缝目宽度/ HOW TO CONTROL THE WIDTH OF ZIGZAG STITCH	10
13 机针与旋梭的关系/ NEEDLE-TO-HOOK RELATIONSHIP	11
14 常见问题故障排解/ TROUBLESHOOTING CHART	12-13

零件样本/ Parts Book

1 机壳分组件/ Machine body	14-15
2 上轴、竖轴、挑线机构/ Needle bar and thread take-up mechanism	16-17
3 摆针机构/ Needle bar components	18-19
4 缝目调节机构/ Presser foot mechanism	20-21
5 下送布机构/ Feed mechanism	20-21
6 抬压脚机构/ Presser foot mechanism	23-24
7 多点摆针机构/ 3&4 Points mechanism	23-24
8 上送料机构/ Upper feed mechanism	25-26
9 立柱机构/ Poster bend mechanism	27-28
10 自动抬压脚机构/ Automatic presser foot lifter	29-30
11 自动倒送料、开关组件/ Automatic reverse feed components	29-30
12 电控部件/ Driver mechanism	31-32
13 供油机构/Oil lubrication mechanism	31-32
14 附件/Assessories	33-34

HIGH SPEED AUTO OILER SINGLE NEEDLE ZIGZAG MACHINE SERIS

操作手册 INSTRUCTION MANUAL

1512&1512DD&1512-7 1513&1513DD&1513-7 2512&2512DD&2512-7 2513&2513DD&2513-7	高速自动加油曲折缝纫机（大梭）系列 1-NEEDLE, TOP&HIGH SPEED AUTO OILER SINGLE NEEDLE ZIGZAG MACHINE SERIS
--	--

为了提高机器的耐久性，请在使用前详细阅读使用说明书，并请妥善保存好说明书以便随时使用。

操作前应注意事项：

BEFORE OPERATION

1. 机器未加油润滑前，请勿启动机台或试转。
2. 请先确认工作场所使用的电压及相数（单相或三相），并详阅马达铭牌上注明的规格，是否相符。
3. 机台安装完毕，第一试转请先确认机头上轮运转方向。
- ★ 开启电源，并保持低速运转，从机头上轮位置方向观察，上轮运转方向是逆时针旋转。
4. 机台开始使用第一个月，请保持或低于1600转/每分钟速度运转。

Please read this Instruction Manual carefully before using the unit in order to get the most out of it and to enjoy using it for a long time. Please keep this Instruction Manual at hand taking care not to lose it

1. Do not operate the machine even for trial before lubrication it.
2. Confirm that the voltage and phase (single or 3-phase) are correct by checking them against the ratings shown on the motor nameplate.
3. When running your machine for the first time after the set-up, check the rotational direction of the handwheel. ★ Turn on the power switch. Run the machine at a low speed while checking the rotational direction of the handwheel. (The handwheel should turn counterclockwise as observed from the handwheel side.)
4. For the first month run the machine at speed of 1600s.p.m or loss.

操作时应注意事项：

CAUTIONS IN OPERATION

1. 启动电源或机器运转期间，请勿将手靠近机针位置，并保持距离。
 2. 机台操作运转期间，请勿将个人或让他人的头、手指等靠近机头上轮、V型皮带、绕线器或者马达，同时，亦请勿置其它物品靠近上述地方，以免发生危险。
 3. 请勿于移除护指器、皮带罩、与任何其它的保护装置的情况下，操作机器。
 4. 移动V型皮带前，务必先将电源关闭，及马达确实已停止转动，才进行下一动作。
1. Keep your hands away from the needle when you turn on the power switch or while the machine is operating
 2. During operation be careful not to allow your or any other person's head or fingers to come close the handwheel, V-belt, bobbin winder or motor. Also do not place anything close to them
 3. Do not turn the machine with the finger guard, belt cover or any other protectors removed
 4. Be sure to turn off the power switch and confirm that the motor is completely stopp-ed before removing the V-belt.

缝纫规格 Sewing machine specification

1652-□

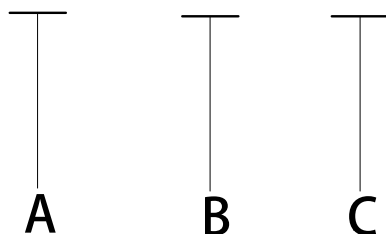

A	1	2	
	下送料 Bottom feed	上下送料 Top and bottom feed	
B	2	3	4
C	—		
	皮带式传动 Belt drive	节能直驱 Direct-drive	电脑车 Direct-drive thread trimmer

台板

1652&2652 Series

台板的厚度应达到 40mm，能够承受缝纫机的重量，并经受得起缝纫机的震动。
请在如图所示位置上钻孔。

台板

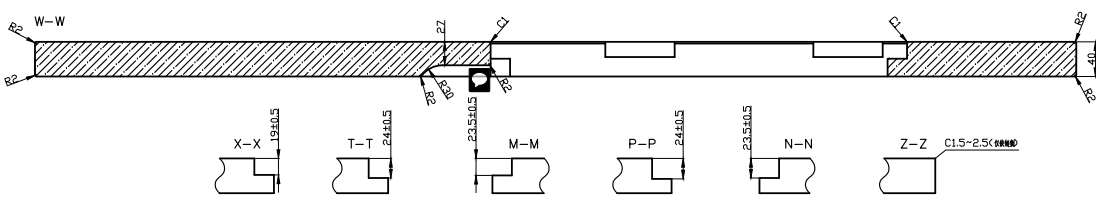
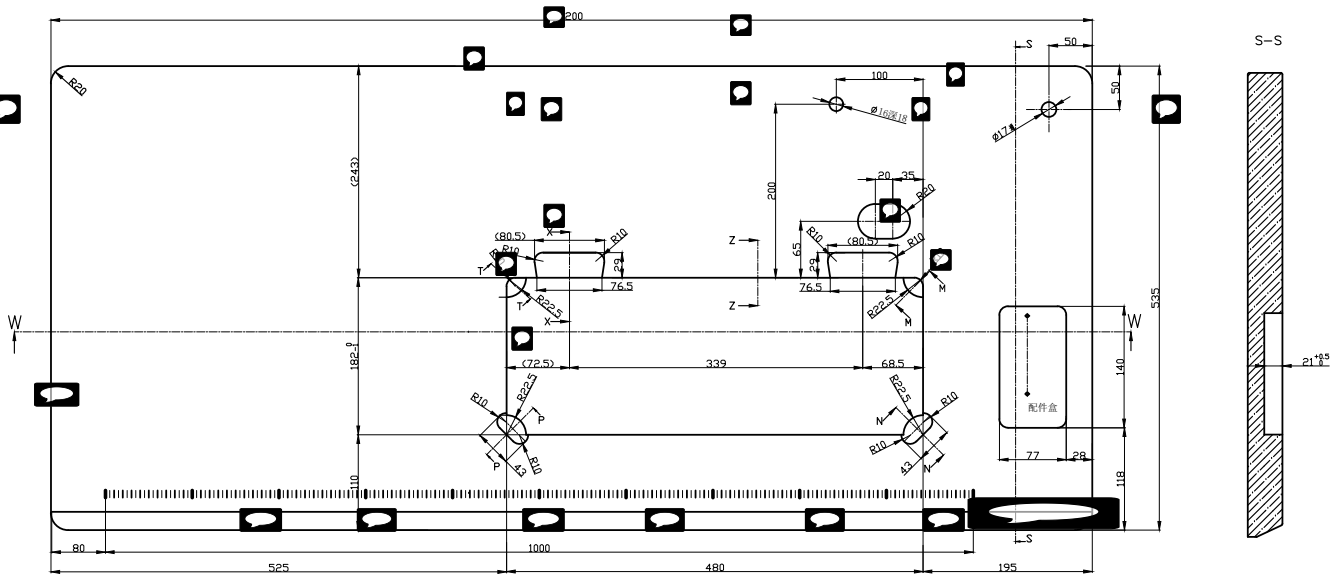

主要技术规格 SPECIFICATIONS

使用	薄料到中厚料
缝纫速度※	最大 2000 s. p. m
缝制长度	前缝：5mm，倒缝：5mm
最大人字宽度	9mm
针杆行程	35mm
压脚提升高度	手动升：8mm，膝提升：13mm
机针	见目次 1★机针和线★
润滑油	机油（白砂油）

※最大的速度是依靠面料、线和缝制条件。

Usage	Light to medium weight material
Sewing speed	Max 2000s p.m
Stitch length	Forward stitch:5mm Reverse stitch:5mm
Max stitch width	9 mm
Needle bar stroke	35 mm
Lift of presser foot	Hand lifter: 8 mm, Knee lifter:13mm
Needle	See page 1 for table on 'NEEDLE AND THREAD'
Lubricating oil	Machine oil (white spindle oil)

※ Maximum speed will very depending on fabris threads and sewing condition

人字宽度和最大速度之间关系

RELATIONSHIP BETWEEN ZIG ZAG WIDTH AND MAXIMUM SPEED

人字宽度	0mm~5mm	5mm~9mm
最大速度	2000 s. p. m	1800 s. p. m
Ziazag width	0mm~5mm	5mm~9mm
Max speed	2000s. p. m	1800s. p. m

1. 机针和线

1.NEEDLE AND THREAD

选择适当的机针不仅依靠机器型号而且也要考材料线的使用，适当的机针和线的尺寸去用在各种机器型号上，请参考以下的规格：

Selection of the proper needle depends not only on the machine model, but also on the material thread used, For selection of proper needle and thread sizes to be used on the various machine model, please refer to the table below

等级应用	薄料	中料	中厚料
最大线尺寸 合成物	120	60	30
机针尺寸	DP×17 #10	DP×17 #12~#16	DP×17 #18~#19

Application of class	For light-weight materials	For medium-weight materials	For medium-heavy wight materials
Max thread size (Nm)-Synthetic	120	60	30
Needle size	DP×17 #10	DP×17 #12~#16	DP×17 #18~#19

2. 缝纫机的安装

2. INSTALLATION OF SEWING MACHINES

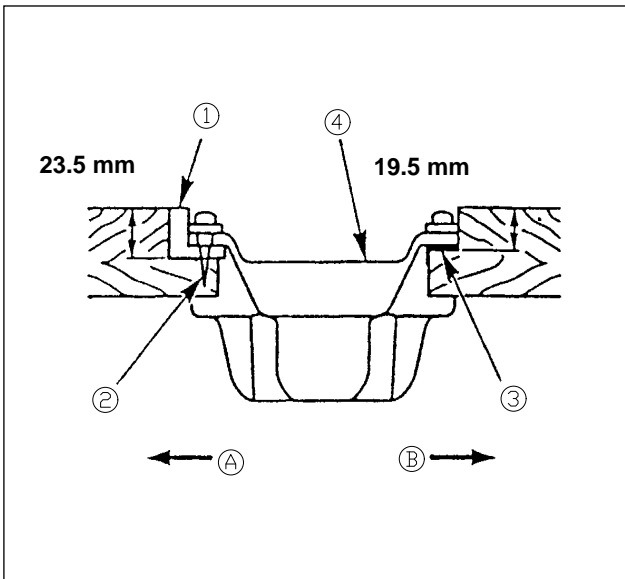

- 1) 把油槽支到机台槽的四角上。
- 2) 用螺丝钉 把前侧(A)的个机头部橡胶支座 钉到机台的伸出部，用粘合剂接固定好铰链侧(B)的2个机头部橡胶垫座 ，然后把油槽 放上。

- 1) The oil pan should rest on the four corners of the machine table groove.
- 2) Two rubber seats ① for supporting the head portion on the operator side are fixed on the extended portion of the table by hitting the nail ② and the other two rubber cushion seats ③ on the hinge side are fixed by using a rubber-based adhesive. Then, oil pan ④ is placed.

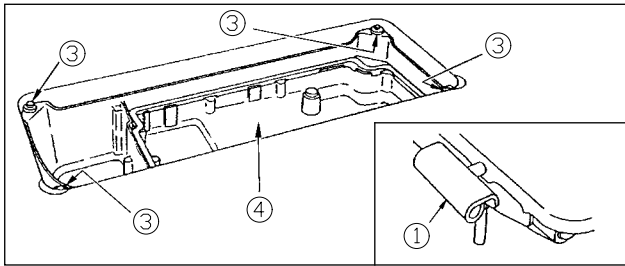

- 3) 把铰链 放到机台的孔上，对准台板橡胶支座 ，把机头放到四角的机头胶垫 上。

- 3) Fit hinge①into the opening in the machine bed, and it the machine head to table rubber hinge ② before placing the machine head on cushions ③ on the four corners.

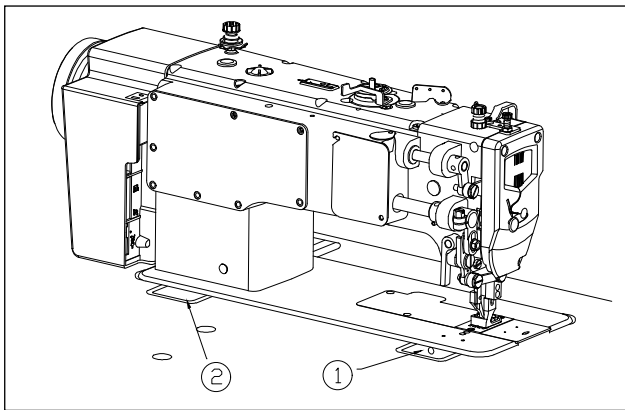

2. 安装膝控抬压脚

2. INSTALLING THE KNEE LIFTER

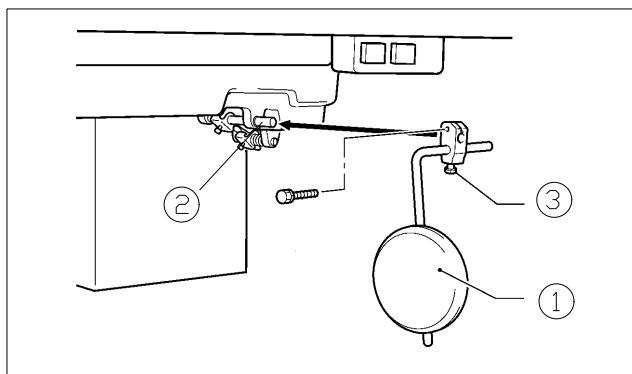

1 1. 膝控碰块

- ① 膝控碰块
- ② 螺栓

* 松开螺栓 ③，将膝控碰块 ①。
移至易于使用的位置。

Insert the knee lifter assy. ① into the shaft ②
under the oil pan, and slightly tight the screw ③.

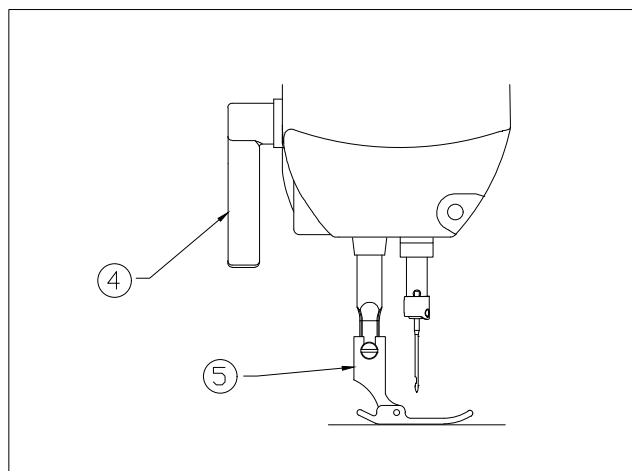

<调整抬压杠杆>

1. 转动手轮以便送布牙处于针板的下方。
2. 用压脚扳手 ④放下压脚 ⑤。

Turn the handwheel so that the feed teeth
④ are under the needle plate ⑤.

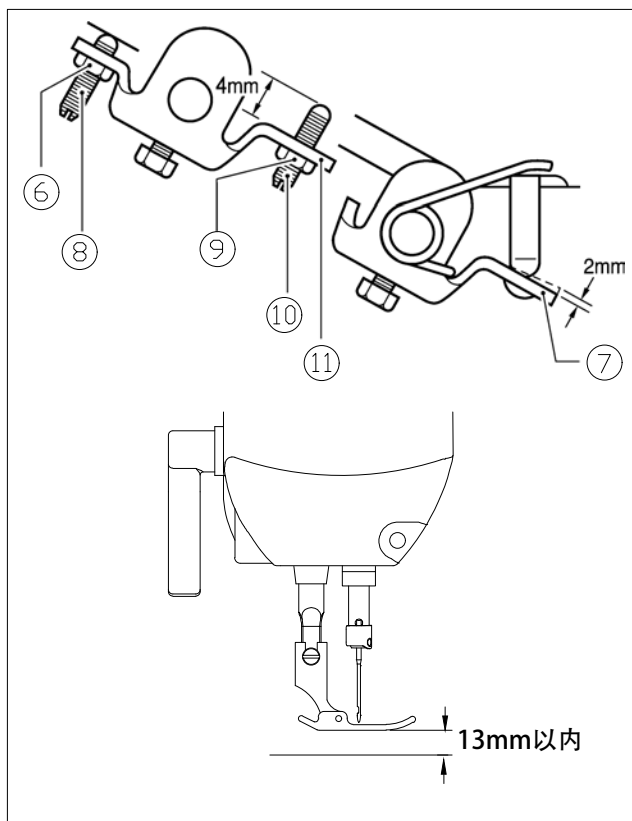

3. 松开螺母 ⑥。
 4. 转动螺钉 ⑧ 进行调节，以使用手在轻压膝控碰块 ① 时抬压杠杆 ⑦ 游隙量约为 2mm。
 5. 完成调节后，将拧紧螺母 ⑥。
 6. 松开螺母 ⑨。
 7. 转动螺钉 ⑩ 直至螺钉头与抬压杠杆 ⑪ 的间距约为 4mm。
 8. 转动调节螺钉 ⑩ 进行调节，以便在完全压下膝控碰块 ① 时，压脚 ⑤ 处在针板上方 10mm 范围内的位置。
 9. 完成调节后，将螺母 ⑨ 拧紧。
3. Loosen the nut ⑥.
4. Turn the screw ⑧ to adjust the bracket ⑦ to 2mm play.
5. Securely tighten the nut ⑥.
6. Loosen the nut ⑨.
7. Turn the screw ⑩ until the distance between the end of the screw and bracket ⑪ is approximately 4mm.
8. Turn the adjusting screw ⑩ to adjust, so that the presser foot ⑤ is at the desired position within a distance of 13mm above the needle plate.
9. After adjustment, tighten the nut ⑨.

3. 润滑油 3.LUBRICATION

* 注意：进行此步骤时，务必将电源关掉，马达确保停止转动，以避免不必要的危险！

⚠ CAUTION TURN THE SWITCH OFF THE POWER SUPPLY TO PREVENT FROM UNEXPECTED INJURY. BE SURE TO CONFIRM THE STOP OF ROTATION OF THE MOTOR BEFORE OPERATIONS.

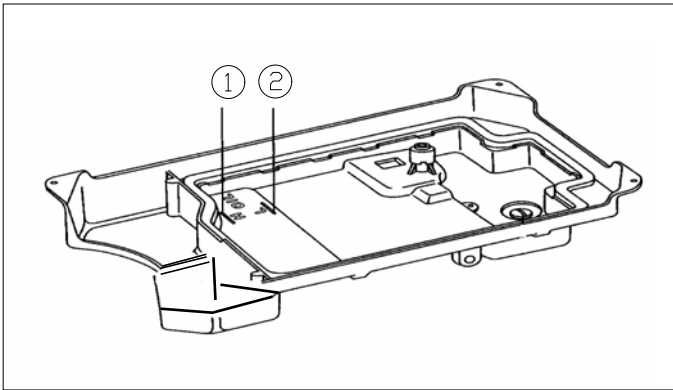

- 1) 把油注入标记线“H”①。
- 2) 当油杆到入在标注“L”②，再次注入油。
(使用油：白砂油)

- 1) Fill oil up to marker in “H” ①.
- 2) When the oil level drops under marker line “L” ②, refill it.
(Using oil is white spindle oil,)

4. 润滑油调节 4.LUBRICATION CONDITION

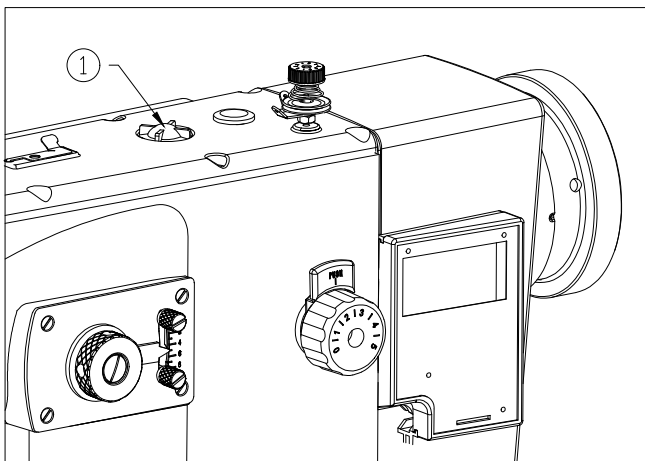

- 1) 操作缝纫机并确定散射油石在油槽里①。

- 1) Operate the sewing machine, and confirm the scattering oil at oily window①.

5. 机针的安装

5.HOW TO INSTALL THE NEEDLE

* 注意：进行此步骤时，务必将电源关掉，马达确保停止转动，以避免不必要的危险！



CAUTION

TURN THE SWITCH OFF THE POWER SUPPLY TO PREVENT FROM UNEXPECTED INJURY. BE SURE TO CONFIRM THE STOP OF ROTATION OF THE MOTOR BEFORE OPERATIONS.

☆ 确保电机电源关闭

标准机针系统是"DPX17"。

- 1) 用手打开手轮并拿起针杆放在顶部位置
- 2) 松开螺丝①，把机针②插入到孔里面直到不能插到顶为止。
◇把机针插入在直接面对直立面的凹槽③。
- 3) 在机针上牢固的锁紧螺丝。

BE SURE TO POWER-OFF THE MOTOR. The normal needle system is 'DPX17' .

- 1) Turn the handwheel by hand and raise the needle bar to its top position.
- 2) Loosen screw ① and insert the needle ② into the hole until it will go on further. Insert the needle with its recess ③ facing directly to rear side.
- 3) Securely tighten the screw in the needle

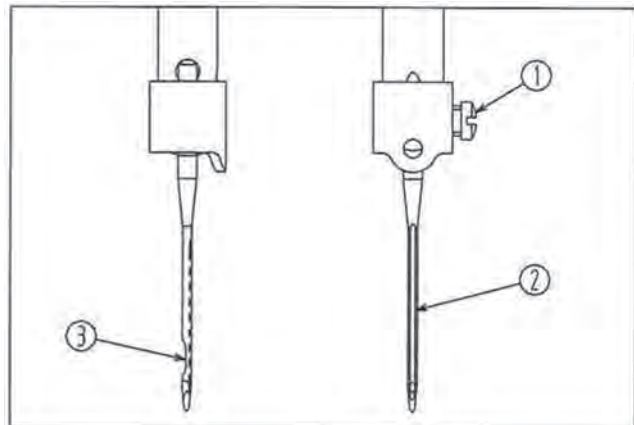

6. 旋梭的安装

6.HOW TO INSTALL THE BOBBIN

* 注意：进行此步骤时，务必将电源关掉，马达确保停止转动，以避免不必要的危险！



CAUTION

TURN THE SWITCH OFF THE POWER SUPPLY TO PREVENT FROM UNEXPECTED INJURY. BE SURE TO CONFIRM THE STOP OF ROTATION OF THE MOTOR BEFORE OPERATIONS.

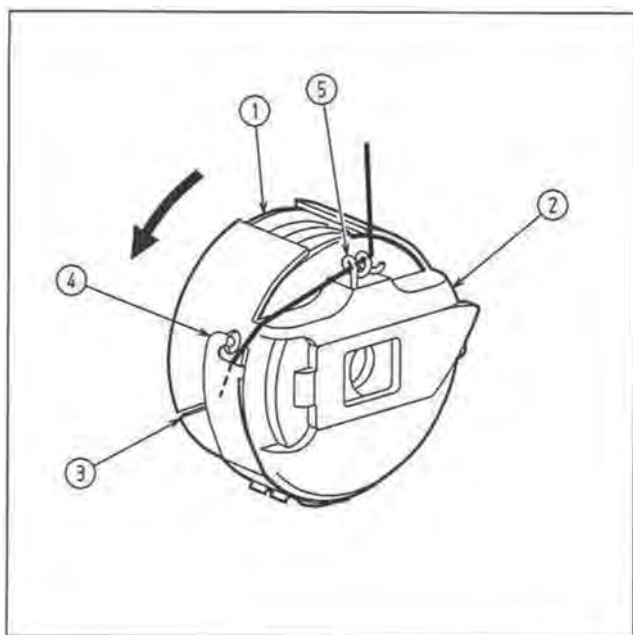

- 1) 把梭芯①放进梭壳里面②。
- 2) 把线穿过线槽③并压住梭壳拉力弹簧的凹槽④。
- 3) 把线尾穿过梭壳的导线器⑤并把它拉出约40mm。

注意：在梭线已经拉出时，安装锁壳的旋梭比便按照箭头的方向打开。

- 1) Put the bobbin ① into the bobbin case ②.
- 2) Pass the thread through the threading groove ③ and notch ④ of tensionspring in the bobbin case.
- 3) Pass the end of thread through bobbin case thread guide ⑤ and pull it a length of about 40mm.

CAUTION: Fit the bobbin in the bobbin case so that the bobbin turns the direction of the arrow when the bobbin thread is pulled.

7. 机器穿线

7. HOW TO THREAD THE MACHINE HEAD

* 注意：进行此步骤时，务必将电源关掉，马达确保停止转动，以避免不必要的危险！

! CAUTION

TURN THE SWITCH OFF THE POWER SUPPLY TO PREVENT FROM UNEXPECTED INJURY. BE SURE TO CONFIRM THE STOP OF ROTATION OF THE MOTOR BEFORE OPERATIONS.

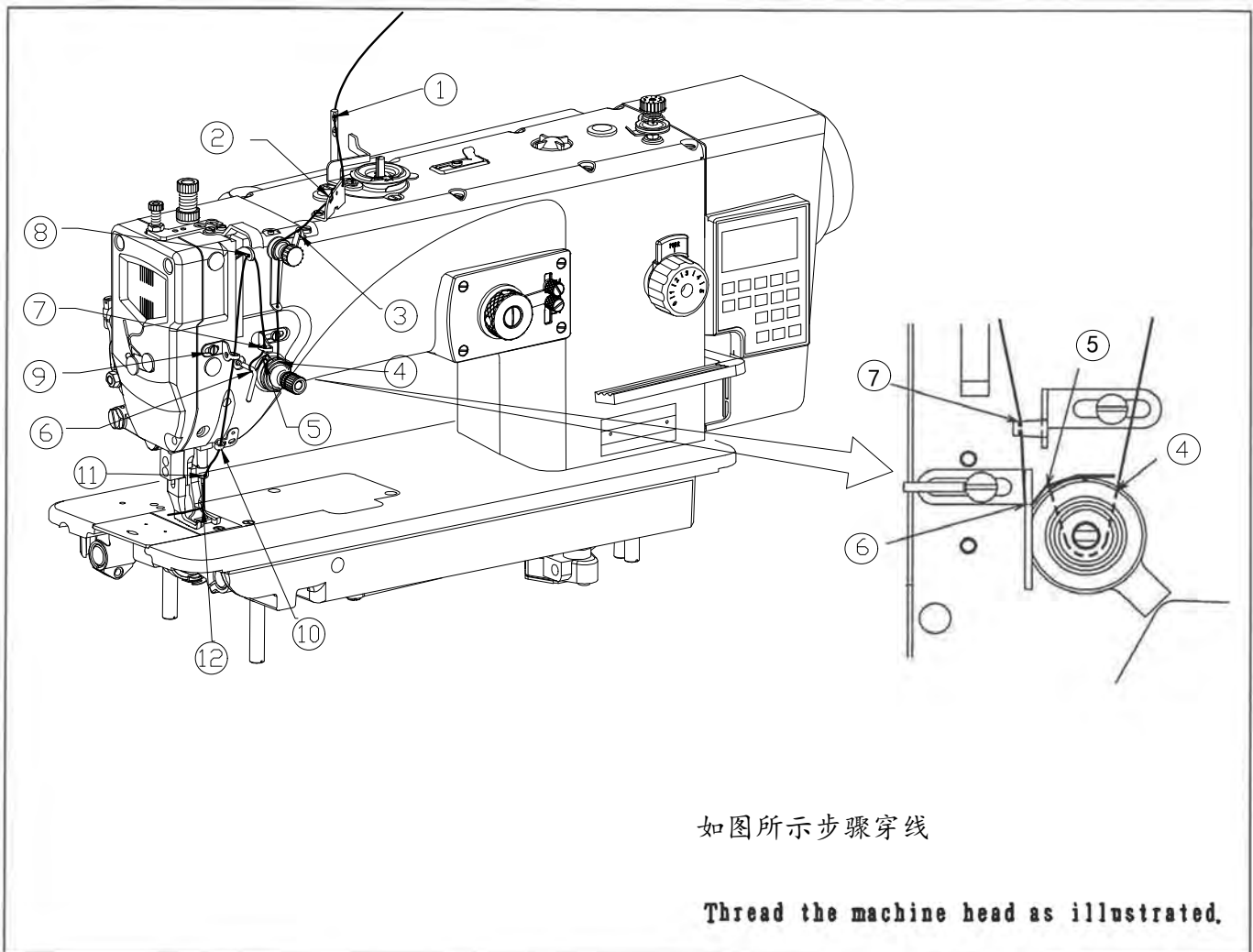

8. 调整缝制长度 8. ADJUSTING THE STITCH LENGTH

* 注意：进行此步骤时，务必将电源关掉，马达确保停止转动，以避免不必要的危险！

⚠ CAUTION TURN THE SWITCH OFF THE POWER SUPPLY TO PREVENT FROM UNEXPECTED INJURY. BE SURE TO CONFIRM THE STOP OF ROTATION OF THE MOTOR BEFORE OPERATIONS.

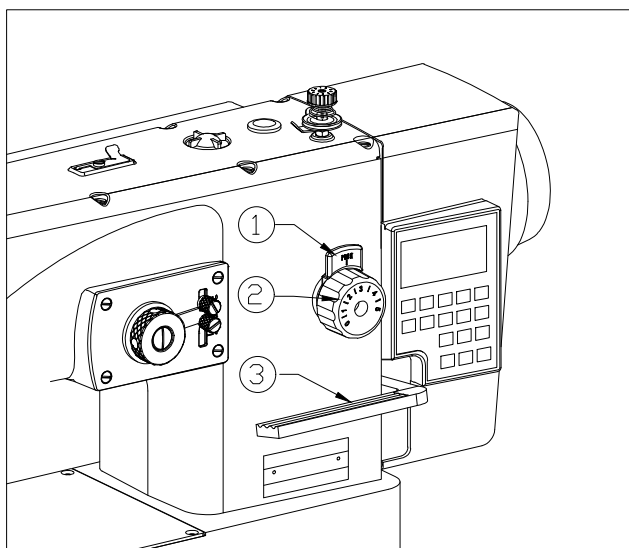

- 1) 推动针距按钮①，打开刻度盘②。
- ◇ 怎么倒送料缝制。
- 1) 把倒缝扳手③压下。
- 2) 只要压住倒缝扳手机器就可以倒送料缝制。
- 3) 松开杆时，机器恢复后标准缝制状态。

- 1) Push the stopper plate ①, and turn the dial ②.
- ◇ How to engage the reverse feed stitching
- 1) Push feed lever ③ down.
- 2) The machine perform revers feed stitching as long as the lever is held depressed.
- 3) The moment you release to leve, the machine resumes the normal stitching mode.

9. 调节压脚压力 9. ADJUSTING THE PRESSER FOOT PRESSURE

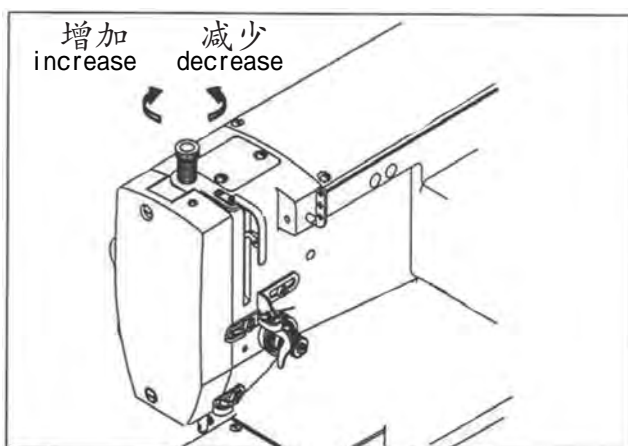

- 1) 向右转动压力调节器增加压力，向左转动减少压力。
- 1) Turn the presser spring regulator to the right to increase and to left to decrease pressure.

10. 线张力调节 10.THREAD TENSION

* 注意：进行此步骤时，务必将电源关掉，马达确保停止转动，以避免不必要的危险！



TURN THE SWITCH OFF THE POWER SUPPLY TO PREVENT FROM UNEXPECTED INJURY. BE SURE TO CONFIRM THE STOP OF ROTATION OF THE MOTOR BEFORE OPERATIONS.

1) 调节沙拉组

顺时针转动沙拉组销①增加线的张力或逆时针转动减少线的张力

2) 调节旋梭线张力

顺时针转动张力螺丝②增加线的张力，逆时针转动减少旋梭线的张力

1) Adjusting the needle thread tension
Turn the thread tension nut ① clockwise to increase or counter clockwise to decrease the needle thread tension.

2) Adjusting the bobbin thread tension
Turn the tension screw ② clockwise to increase or counterclockwise to decrease the bobbin thread tension.

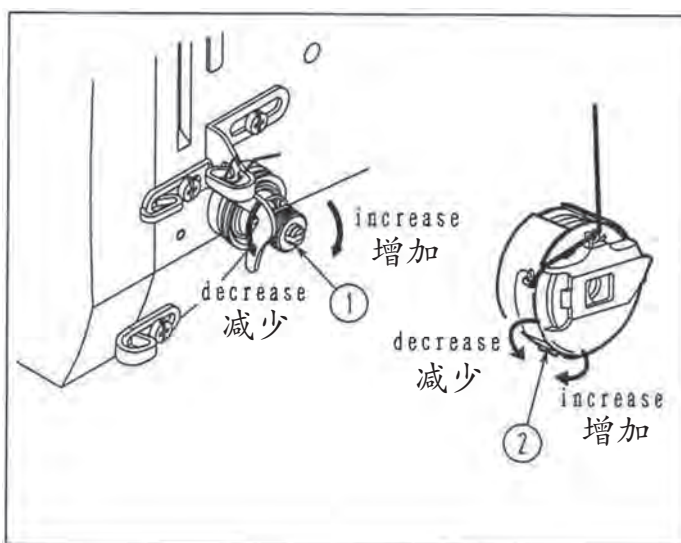

11. 缝目宽度调节器 11.STITCH WIDTH REGULATOR

The width of zigzag stitch is controlled with biased wtwitch width regulakating dial ①.

Do not make any needle position adjustmeny while the needle is in the fabric.

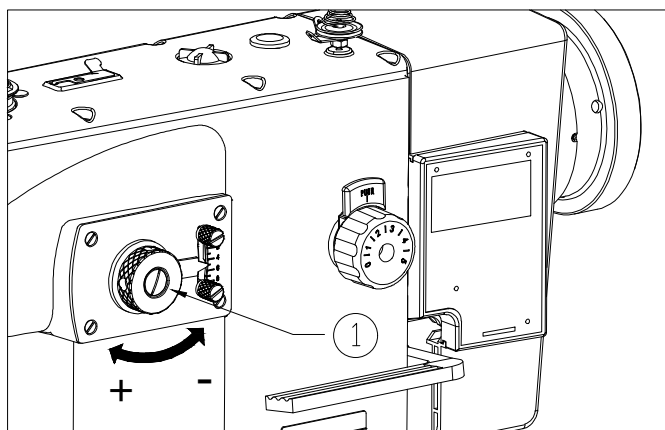

12. 如何控制人字缝目宽度

12.HOW TO CONTROL THE WIDTH OF ZIGZAG STITCH

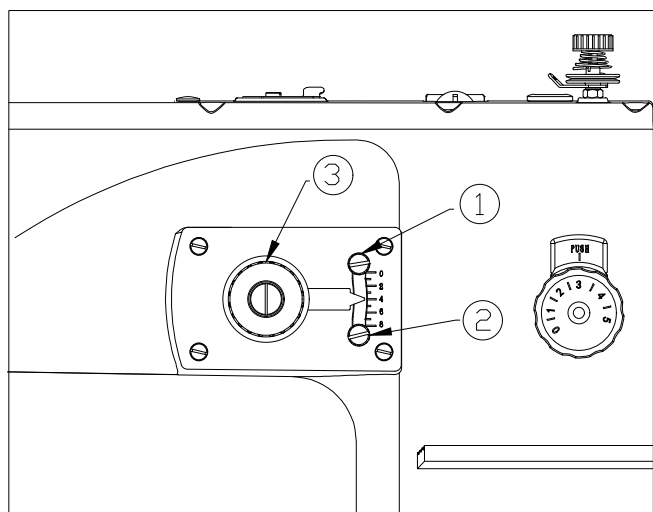

为了控制人字车缝的最小和最大值，首先松开螺丝①，缝目调节器③开始可以调节，转动到最小位置，然后锁紧螺丝①。

松开螺丝②，转动到最大位置，然后锁紧螺丝②。此时你可以控制缝目的调节，或者在0到9mm的范围内调节。

To obtain minimum to maximum width zigzag stitcher, first loosen thumb screw①, to permit the stitch width regulator③, to return to its minimum position and retighten thumb screw①.

Then loosen thumb screw ②, to return to its maximum position and retighten thumb screw ②.

You can now regulate the stitch width regulator within the range of zero to 9mm.

13. 底线卷绕方法

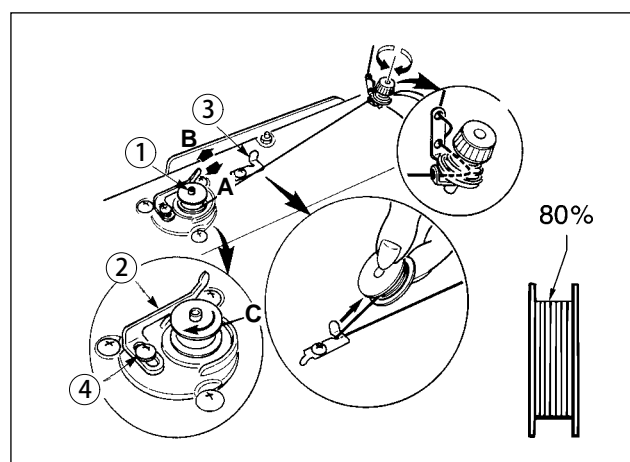

- 1) 把梭心推到卷线轴①的最里面。
- 2) 把线架右侧的卷线如图所示穿线，并把线端向右缠绕数圈。

（铝旋梭时，把线端向右缠绕后，再把线张力盘过来的线向左缠绕数圈后，就容易绕线了。）

- 3) 把卷线拨杆②推到 A 方向，转动缝纫机。梭心向 C 方向转动，线卷绕到梭心上。卷绕结束后卷线轴①自动停止。
- 4) 取下梭心，用切线保持板③切断机线。
- 5) 调整底线卷线量时，请拧松固定螺丝④，把卷线杆②移动到 A 方向或 B 方向，然后再拧紧固定螺丝④。

1) Insert the bobbin deep into the bobbin winder spindle① until it will go no further.

2) Pass the bobbin thread pulled out from the spool rested on the right side of the thread stand following the order as shown in the figure on the left. Then, wind the end of the bobbin thread on the bobbin several times.

3) Press the bobbin winder trip latch ② in the direction of A and start the sewing machine. The bobbin rotates in the direction of C and the bobbin thread is wound up. The bobbin winder spindle ① will automatically stop as soon as the winding is finished.

4) Remove the bobbin and cut the bobbin thread with the thread cut retainer ③.

5) To adjust the winding amount of the bobbin thread, loosen the setscrew ④ and move the bobbin winder trip latch ② to the direction A or B. Then, tighten the setscrew ④.

To the direction A : Decrease

To the direction B : Increase

A 方向：变少

B 方向：变多

注意：

请将绕线量控制在梭芯容量的 80%。

13. 机针与旋梭的关系 13.NEEDLE-TO-HOOK RELATIONSHIP

* 注意：进行此步骤时，务必将电源关掉，马达确保停止转动，以避免不必要的危险！

⚠ CAUTION TURN THE SWITCH OFF THE POWER SUPPLY TO PREVENT FROM UNEXPECTED INJURY. BE SURE TO CONFIRM THE STOP OF ROTATION OF THE MOTOR BEFORE OPERATIONS.

依下列方式将针杆设定在合适的高度然后

- 1) 移除针板。
- 2) 设定缝目调节器为垂直状态。
- 3) 朝操作者方向转动手轮直到机针到达最低位置。
- 4) 松开机针杆螺丝①，此时只有针杆②可以自由的上下移动。
- 5) 按要求向上或下移动针杆②使其上部的计时刻度③与针杆夹④底部对齐，然后安全锁紧针杆螺丝①。

依下列方式调节机针与旋梭的时间

- 1) 在机针处于中间位置时设定机器为垂直车缝状态。
- 2) 依次调节，当机杆上升2.8mm位置时，旋梭尖⑤接触机针⑥的中间部位，此时锁紧旋梭的固定螺丝。（此时调节的粗略指示，针杆上的刻度线⑦与摆针架底面④对齐。）是粗略的指示。
- 3) 调节机针⑥与旋梭尖⑤之间间隙在0.02~0.05mm之间。

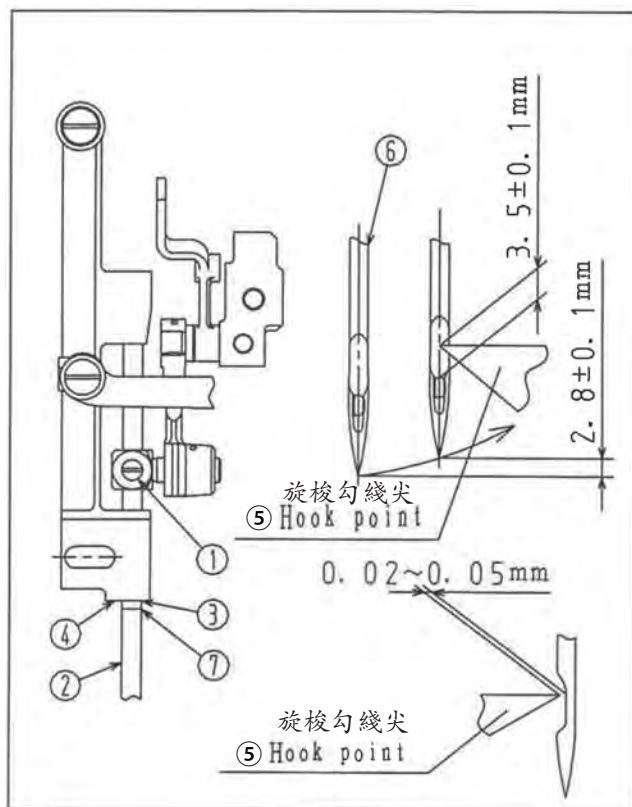

◇Set the needle bar at the proper height first as follows

- 1) Remove face plate.
- 2) Set stitch width regulator for straight stitching.
- 3) Turn machine pulley over toward you until needle descends to its lowest position.
- 4) Loose needle bar screw 1 so that only the needle bar 2 will move up and down freely.
- 5) Move needle bar 2 up or down as required, and align upper timing mark 3 with under side of needle bar frame 4. then securely tighten needle bar set screw 1.

◇Adjust the timing between the needle and the hook as follows

- 1) Set machine for straight stitching at center needle position.
- 2) Adjust so that, when the needle bar goes up to 2.8mm above its lowest position, hook point 5 nearly meets the center of needle 6. Then tighten hook setscrew (As a rough indication of this adjustment, marker line 7 on needle bar aligns with the bottom face of the needle bar frame 4.)
- 3) Adjust the clearance between needle 6 and hook point 5 to 0.02 to 0.05mm.

14. 常见问题故障排除

问题	原因	解决方案
上线断裂	<ol style="list-style-type: none"> 1. 穿线是否正确? 2. 过线器及调节区域线头是否清除? 3. 面线张力是否太紧? 4. 机针是否弯曲或机针尖锐化? 5. 机针是否安装正确? 6. 对于工作材质及线的规格, 及所用机针是否正确? 7. 线有无打结搓捻? 	<ol style="list-style-type: none"> 1. 更正穿线 2. 将线头及毛球从旋梭壳及旋梭中移除 3. 调节面线张力 4. 更换机针 5. 从新正确安装机针 6. 更换适用规格的机针及线 7. 将打结搓捻的线去除
底线断裂	<ol style="list-style-type: none"> 1. 底线穿线是否正确? 2. 底线卡住或缠线? 3. 底线张力是否正确? 4. 旋梭运转是否平衡? 	<ol style="list-style-type: none"> 1. 从新传底线 2. 从锁壳夹线弹簧片将卡线解除 3. 调整底线张力 4. 检查旋梭绕线线有无正确
车线跳针	<ol style="list-style-type: none"> 1. 机针安装是否正确? 2. 机针是否弯曲或机针尖锐化? 3. 机针与线的要求是否符合? 4. 上线穿线是否正确? 	<ol style="list-style-type: none"> 1. 从新正确安装机针 2. 更换新机针 3. 选配适合工作材料的机针 4. 更正穿线动作顺序
断机针	<ol style="list-style-type: none"> 1. 机针安装是否正确? 2. 机针是否弯曲或机针尖锐化? 3. 机针与线的要求是否符合? 4. 锁机针螺丝是否脱落? 5. 车缝中物料有无被拉住? 	<ol style="list-style-type: none"> 1. 从新正确安装机针 2. 更换新机针 3. 选配适合工作材料的机针 4. 锁紧锁机针螺丝 5. 车缝中不要将物料拉住
布料无法送料	<ol style="list-style-type: none"> 1. 送料调节盘是否过度调节? 2. 压脚压力是否有适度调节? 	<ol style="list-style-type: none"> 1. 转动送料调节盘加长缝目长度 2. 加强压脚压力
布料起皱	<ol style="list-style-type: none"> 1. 机针安装是否正确? 2. 机针是否弯曲或机针尖锐化? 3. 线张力是否太紧? 	<ol style="list-style-type: none"> 1. 更正穿线顺序 2. 更换机针 3. 适度调整线张力
回转噪音大	<ol style="list-style-type: none"> 1. 送料齿处是否有线头或毛球? 2. 旋梭中是否有线头? 	<ol style="list-style-type: none"> 1. 清除送料齿处线头毛屑 2. 清除旋梭中的线头毛屑
机器无法启动	<ol style="list-style-type: none"> 1. 电源插头是否有连接电源? 2. 电源开关是否在ON的位置? 	<ol style="list-style-type: none"> 1. 将插头连接电源 2. 电源开关激活在ON位置

14. TROUBLESHOOTING CHART

Problem	Cause	Solution
Needle thread break	1. Is machine properly threaded	1. Correct needle threading
	2. Are thread guides or tension disc area lint-free?	2. Remove lint and fluff in bobbin case and book
	3. Is needle-thread tension too tight?	3. Adjust needle thread tension
	4. Is needle bent or have a blunt point?	4. Replace the new needle
	5. Is needle inserted correctly?	5. Insert needle correctly
	6. Is needle the correct size for thread and fabric?	6. Select proper needle size and thread
	7. Is thread free of slubs and knots?	7. Remove slubs and knots
Bobbin thread breaks	1. Is bobbin threading correct?	1. Correct bobbin threading
	2. Is thread tangled or caught?	2. Untangle thread from bobbin case thread tension
	3. Is thread tension correct?	3. Adjust needle and bobbin case thread tension
	4. Does bobbin rotate smoothly?	4. Check correctly
Stitches skip	1. Is needle inserted correctly?	1. Insert needle correctly
	2. Is needle bent or have blunt needle point?	2. Replace the new needle
	3. Is size of needle and thread suitable for fabric?	3. Select proper needle size and thread
	4. Is threading correct?	4. Correct needle threading
Needle breaks	1. Is needle properly inserted?	1. Insert needle correctly
	2. Is needle bent?	2. Replace the new needle
	3. Is needle the correct size for the fabric?	3. Select proper needle and thread for fabric
	4. Is needle clamping screw loose?	4. Tighten needle set screw
	5. Is the fabric pulled while sewing?	5. Do not pull fabric while sewing
Fabric fails to feed	1. Is feed regulating dial properly adjusted?	1. Lengthen stitch length by feed regulating dial
	2. Is presser foot pressure adjusted properly?	2. Increase presser foot pressure
Fabric puckers	1. Is needle threading correct?	1. Correct needle threading
	2. Is needle point blunt?	2. Replace the new needle
	3. Is thread tension too tight?	3. Adjust needle tension properly
Rotating heavy noisy	1. Is there any lint or fluff on feed dog?	1. Remove lint and fluff from feed dog
	2. Is there any lint in rotating hook?	2. Remove lint and fluff from rotating hook
Machine fails to start	1. Are electrical plugs properly connected?	1. Connect plug to power source
	2. Is power and light switch turned on?	2. Turn on power switch

Parts Manual

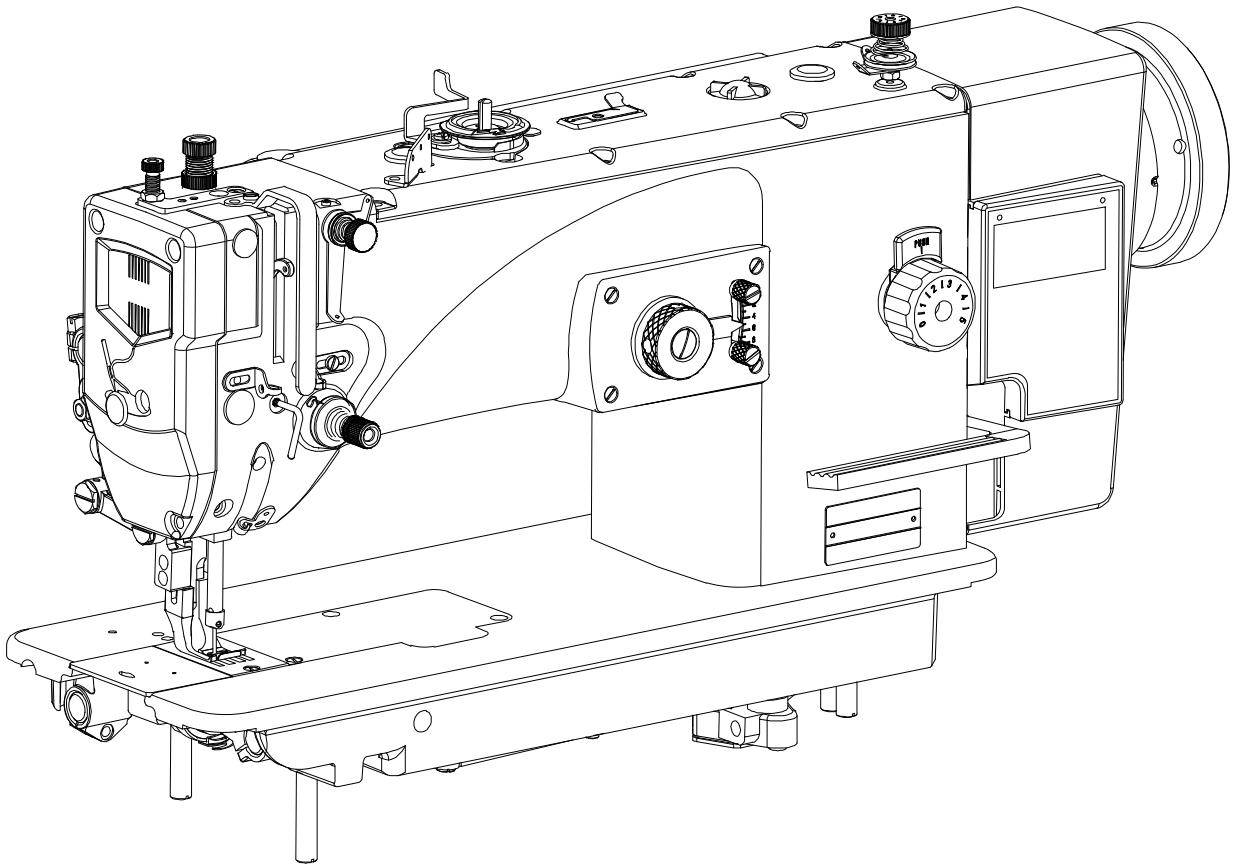

1. 机壳分组件/Machine boby

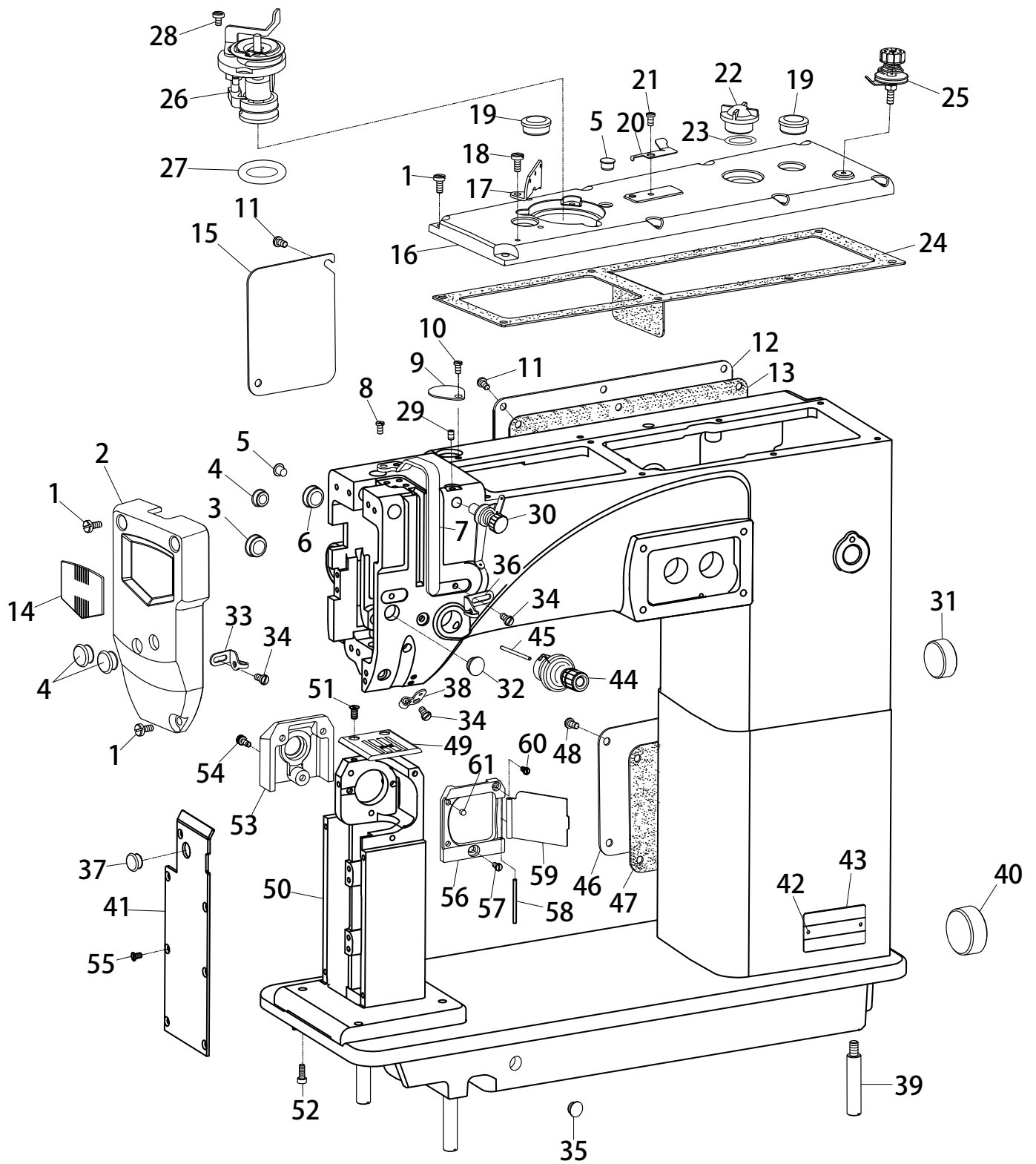

1. 机壳分组件/Machine boby

序号 No.	图号 Part No.	名称	DESCRIPTION	数量 QTY	备注Remark
1	16521-001	螺丝11/64-40 L=10	Screw 11/64-40 L=10	11	
2	16521-002	面板	Face plate	1	
3	16521-003	橡皮塞	Rubber plug 010.8x5	1	
4	16521-004	橡皮塞	Rubber plug 011.8x5	3	
5	16521-005	橡皮塞	Rubber plug 08.8x5	7	
6	16521-006	橡皮塞	Rubber plug 015.5x5	1	
7	16521-007	挑线杆防护罩	Thread take-up lever cover	1	
8	16521-008	螺丝11/64-40 L=8	Screw 11/64-40 L=8	2	
9	26521-009	挡板	Plate	1	01#
10	26521-010	螺丝11/64-40 L=5	Screw 11/64-40 L=5	1	01#
11	16521-011	螺丝3/16-28 L=9	Screw 3/16-28 L=9	10	
12	16521-012	后窗板	Side plate	1	
13	16521-013	后窗板垫	Gasket	1	
14	16521-014	面板贴	Face plate	1	
15	26521-015	侧板	Side plate	1	01#
16	16521-016	顶盖	Top cover	1	
17	16521-017	三孔线勾	Thread retainer	1	
18	16521-018	螺丝3/16-28 L=6	Screw 3/16-28 L=6	1	
19	16521-019	橡皮塞	Rubber plug 018.8x6	2	
20	16521-020	割线刀	Cutter	1	
21	16521-021	螺丝3/16-28 L=6	Screw 3/16-28 L=6	1	
22	16521-022	油窗	Oil sight window	1	
23	16521-023	油窗O型圈	Rubber ring	1	
24	16521-024	顶盖垫	Top cover packing	1	
25	16521-025	底线夹线器	Bobbin thread tension	1	
26	16521-026	绕线器	Bobbin winder	1	
27	16521-027	绕线器O型圈	Rubber ring	1	
28	16521-028	螺钉3/16-32 L=7	Screw 3/16-32 L=7	3	
29	16521-029	螺丝11/64-40 L=6	Screw 11/64-40 L=6	1	
30	16521-030	小夹线器组件	Thread guide assy	1	
31	16521-031	橡皮塞	Rubber plug 022.3x7	1	
32	16521-032	橡皮塞	Rubber plug 012.8x7.5	1	
33	16521-033	左线勾	Thread guide	1	
34	16521-034	螺丝9/64-40 L=7	Screw 9/64-40 L=7	3	
35	16521-035	橡皮塞	Rubber plug 011.8x5	1	
36	16521-036	右线勾	Arm thread guide-Right	1	
37	16521-037	橡皮塞	Rubber plug 010.8x5	1	
38	16521-038	过线套	Rubber bushing	1	
39	16521-039	底板支柱	Bed screw stud	4	
40	16521-040	橡皮塞	Rubber plug 027x9	1	
41	16521-041	盖板	Cover plate	1	
42	16521-042	型号牌铆钉	Pole	2	
43	16521-043	型号牌	Model plate	1	
44	16521-044	夹线器组件	Thread tension bracket assy.	1	
45	16521-045	松线辅钉	Tension release pin	1	
46	16521-046	后盖板	Side plate	1	
47	16521-047	后盖板垫	Gasket	1	
48	16521-048	螺丝 11/64-40 L=8	Screw 11/64-40 L=8	5	
49	16521-049	针板	Throat plate	1	
50	16521-050	立柱座	Column seat	1	
51	16521-051	螺丝 11/64-40 L=8	Screw 11/64-40 L=8	2	
52	16521-052	螺丝 M6 L=16	M6 L=16	4	
53	16521-053	轴承座	Bearing housing	1	
54	16521-054	螺丝 M4 L=10	M4 L=10	3	
55	16521-055	螺丝 9/64-40 L=6	Screw 9/64-40 L=6	7	
56	16521-056	旋梭定位勾	Positioning finger	1	
57	16521-057	螺丝 11/64-40 L=8	Screw 11/64-40 L=8	1	
58	16521-058	销	Pin	1	
59	16521-059	盖板	cover	1	
60	16521-060	螺丝 9/64-40 L=8	Screw 9/64-40 L=8	1	
61	16521-061	磁钢	magnetic steel	2	

01#:For 2652D;2653D;2654D

2. 上轴. 竖轴. 挑线机构/Upper shaft mechanism

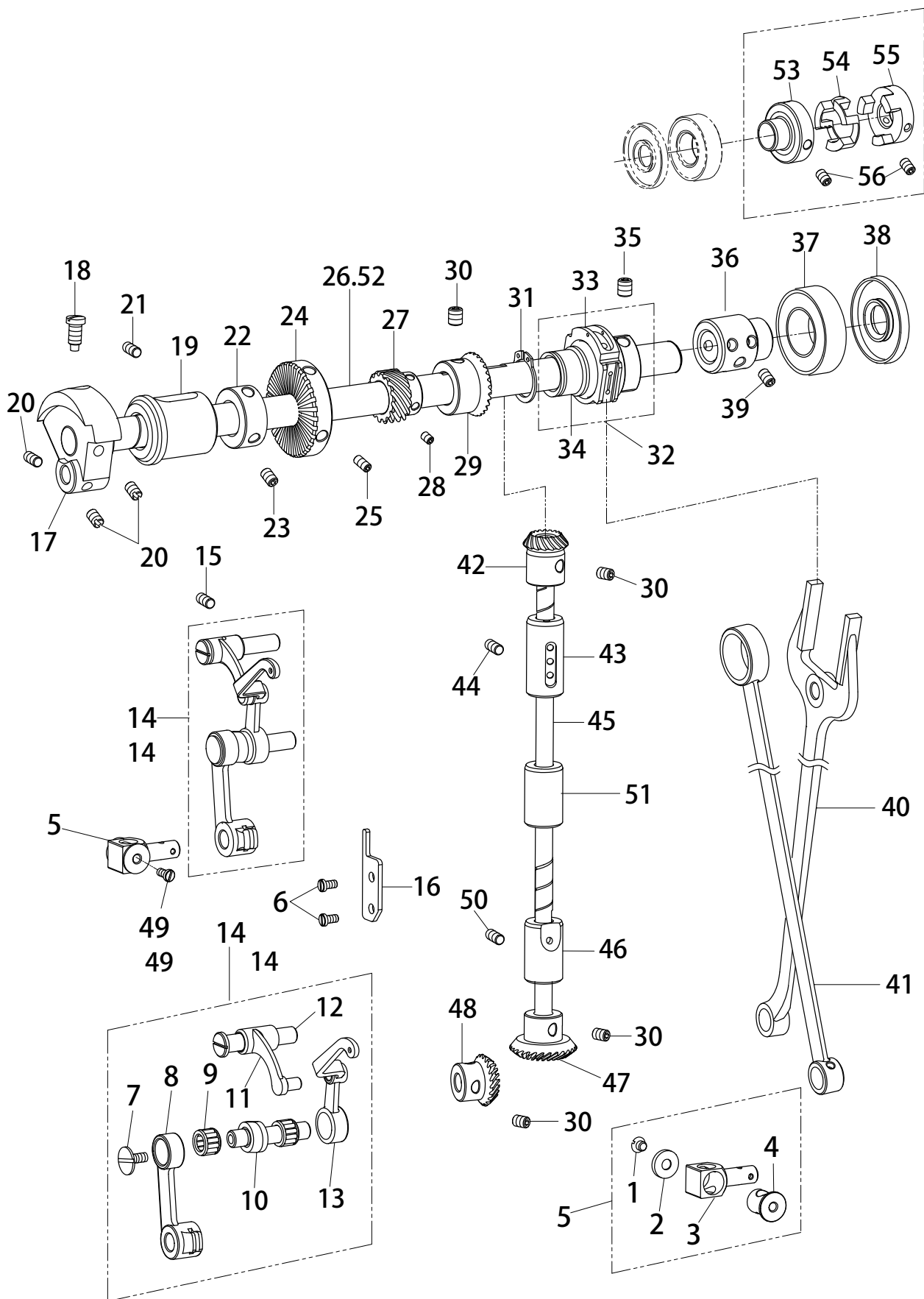

2. 上轴. 竖轴. 挑线机构/Upper shaft mechanism

序号 No.	图号 Part No.	名称	DESCRIPTION	数量 QTY	备注Remark
1	16522-001	螺丝 11/64-40 L=3.5	Screw 11/64-40 L=3.5	1	
2	16522-002	垫片	Washer	1	
3	16522-003	针杆接头	Needle bar clamp	1	
4	16522-004	针杆接头销	Bush	1	
5	16522-005	针杆接头组件	Needle bar clamp assy	1	
6	16522-006	螺丝 11/64-40 L=6	Screw 11/64-40 L=6	2	
7	16522-007	L螺丝 9/64-40 L=4.8	End screw left 9/64-40 L=4.8	1	
8	16522-008	针杆连杆	Needle bar crank rod	1	
9	16522-009	滚针轴承	Needle bearing	1	
10	16522-010	挑线曲柄	Needle bar crank	1	
11	16522-011	挑线连杆	Thread take-up bar	1	
12	16522-012	挑线连杆销	Thread take-up crank shaft	1	
13	16522-013	挑线连杆分组件	Thread take-up lever	1	
14	16522-014	挑线杆组件	Thread take-up lever ASM	1	
15	16522-015	螺丝15/64-28 L=13	Screw 15/64-28 L=13	1	
16	16522-016	针杆连杆导位块	Needle bar link guide	1	
17	16522-017	针杆曲柄	Thread take-up crank	1	
18	16522-018	螺丝9/32x28	Screw SM9/32x28	1	
19	16522-019	上轴前套	Upper shaft bush (front)	1	
20	16522-020	螺丝1/4-40 L=7	Screw 1/4-40 L=7	3	
21	16522-021	螺丝15/64-28 L=13	Screw 15/64-28 L=13	1	
22	16522-022	上轴挡圈	Collar	1	
23	16522-023	螺丝1/4-40 L=8	Screw 1/4-40 L=8	2	
24	16522-024	绕线摩擦轮	Friction wheel	1	
25	16522-025	螺丝11/64-40 L=6	Screw 11/64-40 L=6	2	
26	16522-026	上轴	Upper shaft	1	
27	16522-027	摆针传动齿轮(上)	Bevel gear(upper)	1	
28	16522-028	螺丝11/64-40 L=4	Screw 11/64-40 L=4	2	
29	16522-029	上轴齿轮 Z=3	Upper shaft bevel gear	1	
30	16522-030	螺丝1/4-40 L=6	Screw 1/4-40 L=6	2	
31	16522-031	轴用挡圈	Retaining ring	1	
32	16522-032	送布偏心轮组件	Feed eccentric cam ASM	1	
33	16522-033	牙叉滑块	Silde rlock	1	
34	16522-034	抬牙送布偏心轮	Feed eccentric cam	1	
35	16522-035	螺丝15/64-28 L=8	Screw 15/64-28 L=8	2	
36	26522-036	联轴器	Coupling	1	01#
37	16522-037	轴承	bearing 6004	1	
38	16522-038	上轴油封	Oil seal	1	
39	26522-039	螺丝M6X0.75 L=5	M6X0.75 L=5	6	01#
40	16522-040	送布传动牙叉	Feed dog fork	1	
41	16522-041	抬牙连杆	Connecting rod	1	
42	16522-042	竖轴上齿轮 Z=22	Vertical shaft bevel gear(upper)	1	
43	16522-043	竖轴上套	vertical shaft bush(upper)	1	
44	16522-044	螺丝15/64-28 L=6	Screw 15/64-28 L=6	1	
45	16522-045	竖轴	vertical shaft	1	
46	16522-046	竖轴下套	vertical shaft bush(lower)	1	
47	16522-047	竖轴下齿轮 Z=28	Vertical shaft bevel gear(lower)	1	
48	16522-048	下轴右齿轮 Z=21	Lower shaft bevel gear	1	
49	16522-049	螺丝11/64-40 L=6	Set Screw 11/64-40 L=6	1	
50	16522-050	螺丝15/64-28 L=10	Screw 15/64-28 L=10	1	
51	16522-051	竖轴中套	Vertical shaft middle sleeve	1	
52	26522-052	上轴	Upper shaft	1	01#
53	16522-053	离合器A	Clutch component (A)	1	
54	16522-054	离合器橡胶垫	Alnico tray	1	
55	16522-055	离合器B	Clutch component (B)	1	
56	16522-056	螺丝M6 L=6	M6 L=6	6	

01#:For 2652D;2653D;2654D

3. 摆针机构/Lower shaft mechanism

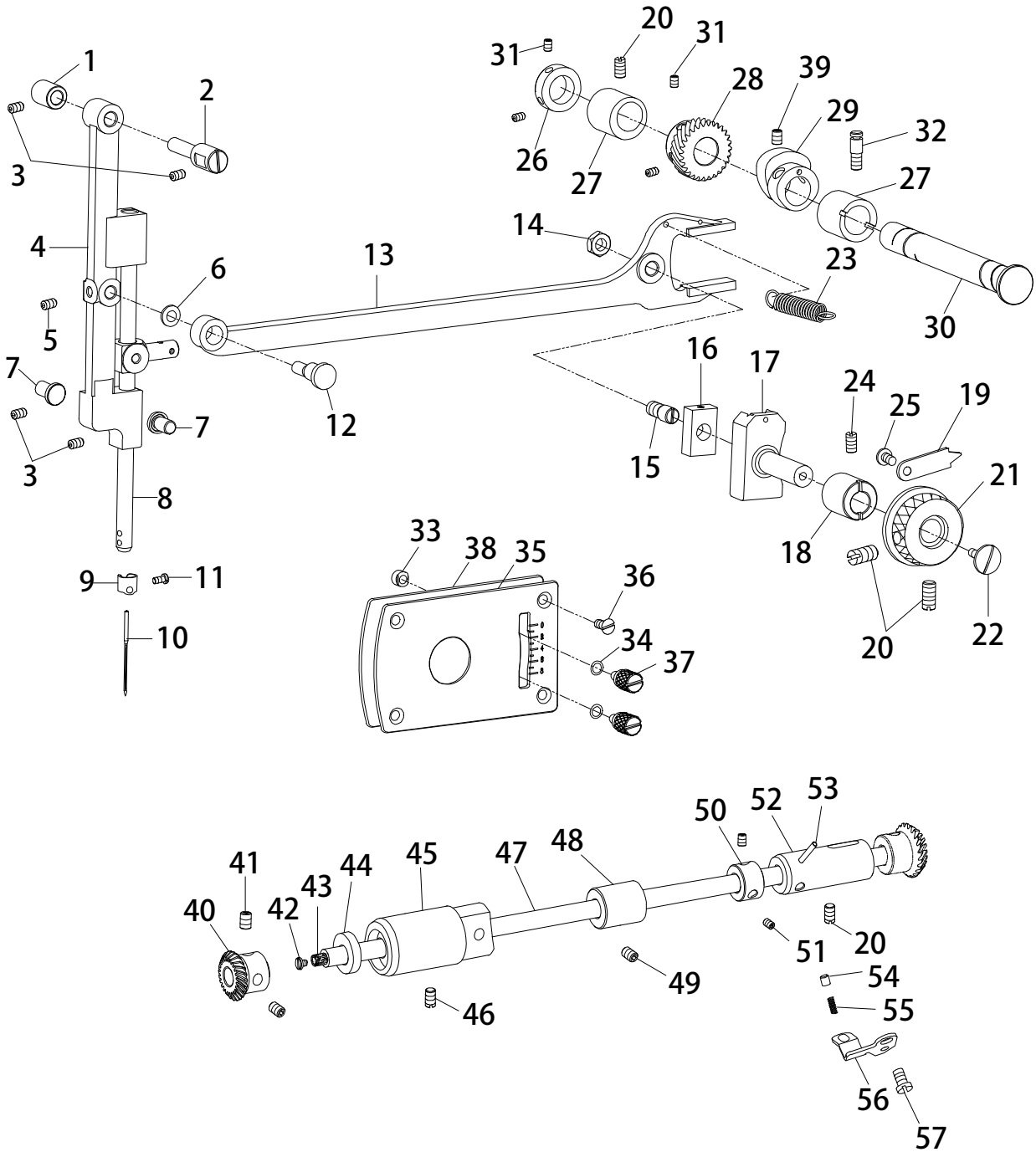

3. 摆针机构&下轴机构/Pendulum mechanism & Lower shaft mechanism

序号 No.	图号 Part No.	名称	DESCRIPTION	数量 QTY	备注Remark
1	16523-001	摆针架悬吊轴套	Needle bar frame pin bush	1	
2	16523-002	摆针架悬吊轴	Needle bar frame pin	1	
3	15123-003	螺丝11/64-40 L=6	Screw 11/64-40 L=6	1	
4	15123-004	摆针架	Needle bar frame	1	
5	15123-005	螺丝11/64-40 L=6	Screw 11/64-40 L=6	1	
6	15123-006	垫片W5*10*1 Washer	W5*10*1 Washer	1	
7	15123-007	摆针架下挡套	Needle bar frame position	1	
8	15123-008	针杆	Needle bar	1	
9	15123-009	针杆过线环	Needle bar thread guide	1	
10	15123-010	机针	Needle	1	
11	15123-011	螺丝 1/8-44 L=4.5	1/8-44 L=4.5	1	
12	15123-012	偏心销	Pin	1	
13	15123-013	摆针传动二叉	Feed dog fork	1	
14	15123-014	螺母 9/32-28 L=4	Nut 9/32-28 L=4	1	
15	15123-015	传动二叉滑块轴	Screw 9/32-28	1	
16	15123-016	传动二叉滑块	Slide block	1	
17	15123-017	传动二叉滑块座	Regulator	1	
18	15123-018	传动二叉滑块座套	Regulator bush	1	
19	15123-019	摆幅指针	Jndicalor	1	
20	15123-020	螺丝15/64-28 L=10	Screw 15/64-28 L=10	1	
21	15123-021	摆幅手转轮	Dial	1	
22	15123-022	螺丝3/16-28 L=8	Screw 11/64-40 L=8	1	
23	15123-023	摆针传动二叉拉簧	Spring holder	1	
24	15123-024	螺丝15/64-28 L=11	Screw 15/64-28 L=11	1	
25	15123-025	螺丝11/64-40 L=7	Screw 11/64-40 L=7	1	
26	15123-026	摆针传动轴挡圈	Collar	1	
27	15123-027	摆针传动轴套	Bush	2	
28	15123-028	摆针传动齿轮(下)	Bevel gear(down)	1	
29	15123-029	摆针传动偏心轮	Cam	1	
30	15123-030	摆针传动轴	Shaft	1	
31	15123-031	螺丝11/64-40 L=4	Screw 11/64-40 L=4	4	
32	15123-032	挂簧螺丝15/64-28	15/64-28	1	
33	15123-033	螺母11/64-40 L=3.5	11/64-40 L=3.5	2	
34	15123-034	O型圈 Rubber ring	Rubber ring	2	
35	15123-035	摆幅指示板	Graduated plate	1	
36	15123-036	螺丝11/64-40 L=7	Screw 11/64-40 L=7	4	
37	15123-037	压花螺丝11/64-40	11/64-40	2	
38	15123-038	板垫	Gasket	1	
39	15123-039	螺丝 15/64-28 L=7	Screw 15/64-28 L=7	2	
40	15123-040	下轴左齿轮	Gear	1	
41	15123-041	螺丝 1/4-40 L=5	Screw 1/4-40 L=5	2	
42	15123-042	下轴滤油螺丝	Lower shaft oil filter screw	1	
43	15123-043	下轴滤油塞	Lower shaft oil filter plug	1	
44	15123-044	下轴油封	Lower shaft oil seal	1	
45	15123-045	下轴前套	Lower axle front sleeve	1	
46	15123-046	螺丝 11/64-40 L=8	Screw 15/64-28 L=8	1	
47	15123-047	下轴	lower shaft	1	
48	15123-048	下轴中套	Lower shaft sleeve	1	
49	15123-049	螺丝 11/64-40 L=8	Screw 15/64-28 L=8	1	
50	15123-050	挡圈	Retaining ring	1	
51	15123-051	螺丝	Screw 15/64-28 L=4	2	
52	15123-052	下轴后轴套	Lower axle rear bushing	1	
53	15123-053	下轴轴套油管	Lower axle bushing oil pipe	1	
54	15123-054	柱塞	Plunger	1	
55	15123-055	柱塞弹簧	Plunger spring	1	
56	15123-056	挡板	Baffle	1	
57	15123-057	挡板螺丝	Screw 15/64-28 L=8	1	

4. 缝目调节机构/Presser foot mechanism

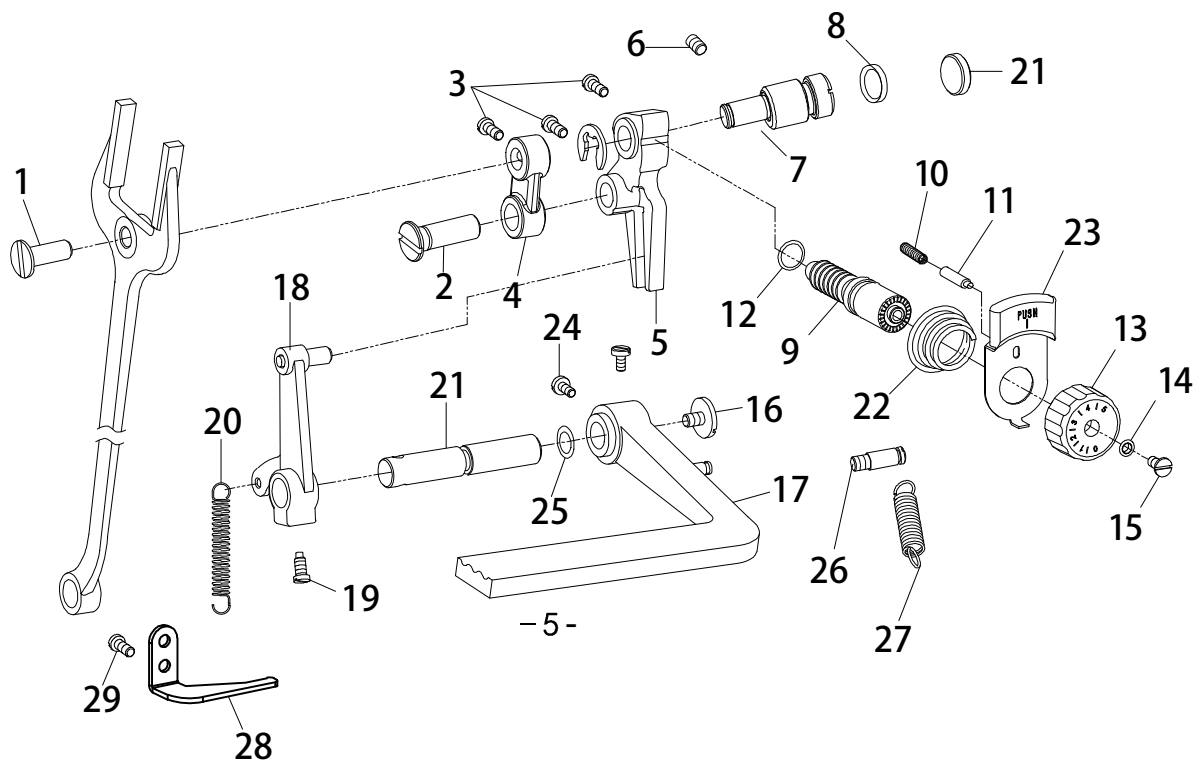

5. 下送布机构/Feed mechanism

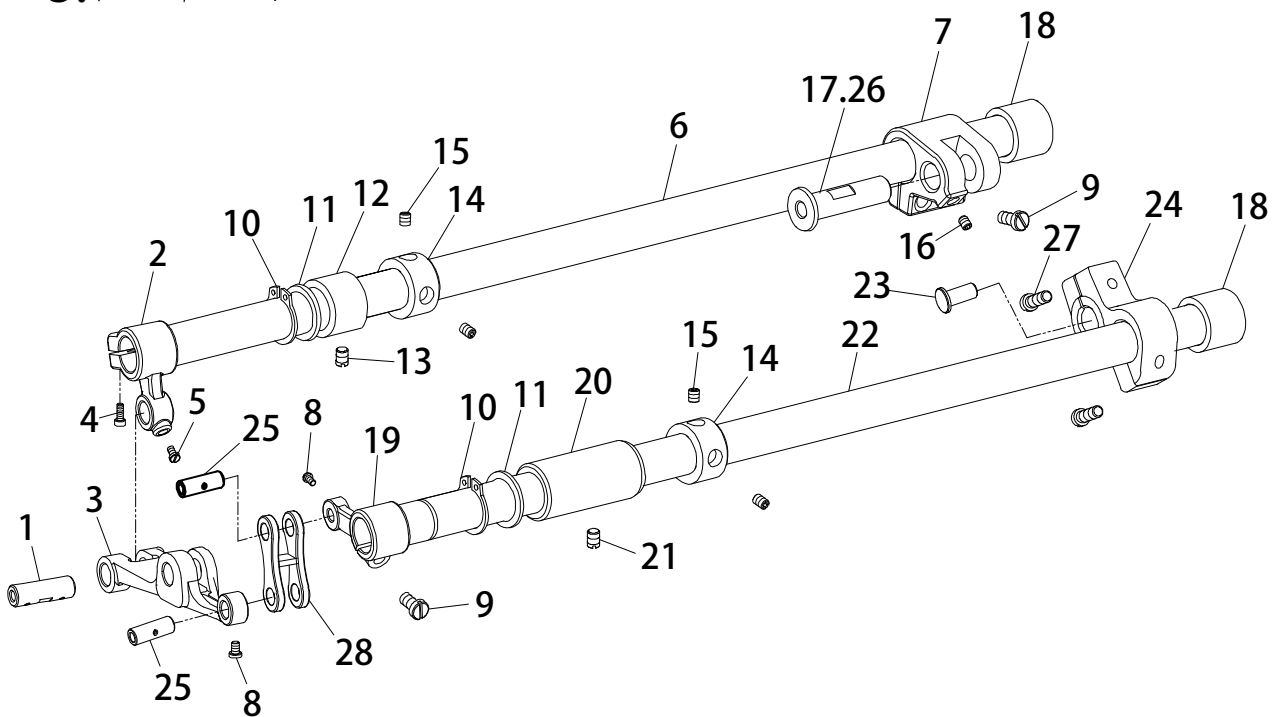

4. 缝目调节机构/Stitch width regulator mechanism

序号 No.	图号 Part No.	名称	DESCRIPTION	数量 QTY	备注Remark
1	16524-001	牙叉铰链轴	Pin	1	
2	16524-002	针距连杆铰链轴	Pin	1	
3	16524-003	螺丝15/64-28 L=8	Screw 15/64-28 L=8	3	
4	16524-004	针距连杆	Feed connecting link	1	
5	16524-005	针距调节摆杆	Feed regulator (forked)	1	
6	16524-006	螺丝15/64-28 L=13	Screw 15/64-28 L=13	1	
7	16524-007	针距调节偏心销	Adjust the eccentric pin	1	
8	16524-008	O型圈	Rubber ring	1	
9	16524-009	针距调节螺杆	Feed regulating stud	1	
10	16524-010	止动销弹簧	Feed spring	1	
11	16524-011	止动销	Feed regulating stud lock	1	
12	16524-012	O型圈	Rubber ring	1	
13	16524-013	针距标盘	Length control plate	1	
14	16524-014	针距标盘垫片	Washer	1	
15	16524-015	螺丝3/16-28 L=15	Screw 3/16-28 L=15	1	
16	16524-016	螺丝3/16-28 L=7	Screw 3/16-28 L=7	1	
17	16524-017	倒缝扳手	Reverse feed control lever	1	
18	16524-018	倒缝操纵曲柄	Reverse feed crank	1	
19	16524-019	螺丝15/64-28	Screw 15/64-28	1	
20	16524-020	复位簧	Reset spring	1	
21	16524-021	倒缝操纵杆轴	Reverse feed control shaft	1	
22	16524-022	针距按钮簧	Spring	1	
23	16524-023	针距按钮	Washer	1	
24	16524-024	螺丝 11/64-40 L=10	Screw 11/64-40 L=10	2	
25	16524-025	O型圈	Rubber ring	1	
26	16524-026	销	Pin	1	02#
27	16524-027	弹簧	Spring	1	02#
28	16524-028	复位簧勾板	Rubber ring	1	
29	16524-029	螺丝 11/64-40 L=10	Screw 11/64-40 L=10	1	

02#:For 2652D;2653D;2654D

5. 下送布机构/Feed mechanism

序号 No.	图号 Part No.	名称	DESCRIPTION	数量 QTY	备注Remark
1	16525-001	牙架销	Shaft	1	
2	16525-002	牙架座	Feed rock arm	1	
3	16525-003	牙架部件	Feed bar asm	1	
4	16525-004	螺丝M5 L=12	M5 L=12	1	
5	16525-005	螺丝 9/64-40 L=5	Screw 9/64-40 L=5	1	
6	16525-006	送料轴	Feed shaft	1	
7	16525-007	送料曲柄	Feed rocker arm	1	
8	16525-008	牙架销螺丝	Screw 9/64-40 L=5	2	
9	16525-009	抬牙曲柄螺丝	Screw 3/16-28 L=14	1	
10	16525-010	挡圈	Collar	2	
11	16525-011	垫片	Collar	2	
12	16525-012	送料轴前轴套	Bush, L	1	
13	16525-013	螺丝 15/64-28 L=6	Screw 15/64-28 L=6	1	
14	16525-014	抬牙送料轴挡圈	Collar	2	
15	16525-015	螺丝 1/4-40 L=5	Screw 1/4-40 L=5	4	
16	16525-016	送料曲柄销螺丝 11/64-40 L=6	Screw 11/64-40 L=6	1	
17	16525-017	送料曲柄销	Walking foot pinb	1	
18	16525-018	送料轴后轴套	Bush, R	2	
19	16525-019	抬牙叉	lifting fork	1	
20	16525-020	抬牙轴前套	Bush, L	1	
21	16525-021	螺丝 15/64-28 L=6	Screw 15/64-28 L=6	1	
22	16525-022	抬牙轴	Feed driving shaft	1	
23	16525-023	抬牙曲柄销	Pin	1	
24	16525-024	抬牙曲柄	Lifting rocker	1	
25	16525-025	抬牙销	Pin	2	
26	26525-026	送料曲柄销	Walking foot pinb	1	01#
27	16525-027	螺丝 3/16-28 L=15.5	Screw 3/16-28 L=15.5	2	
28	16525-028	抬牙曲柄连杆	tooth lift crank connecting rod	1	

01#:For 2652D;2653D;2654D

6. 抬压脚机构/Presser foot mechanism

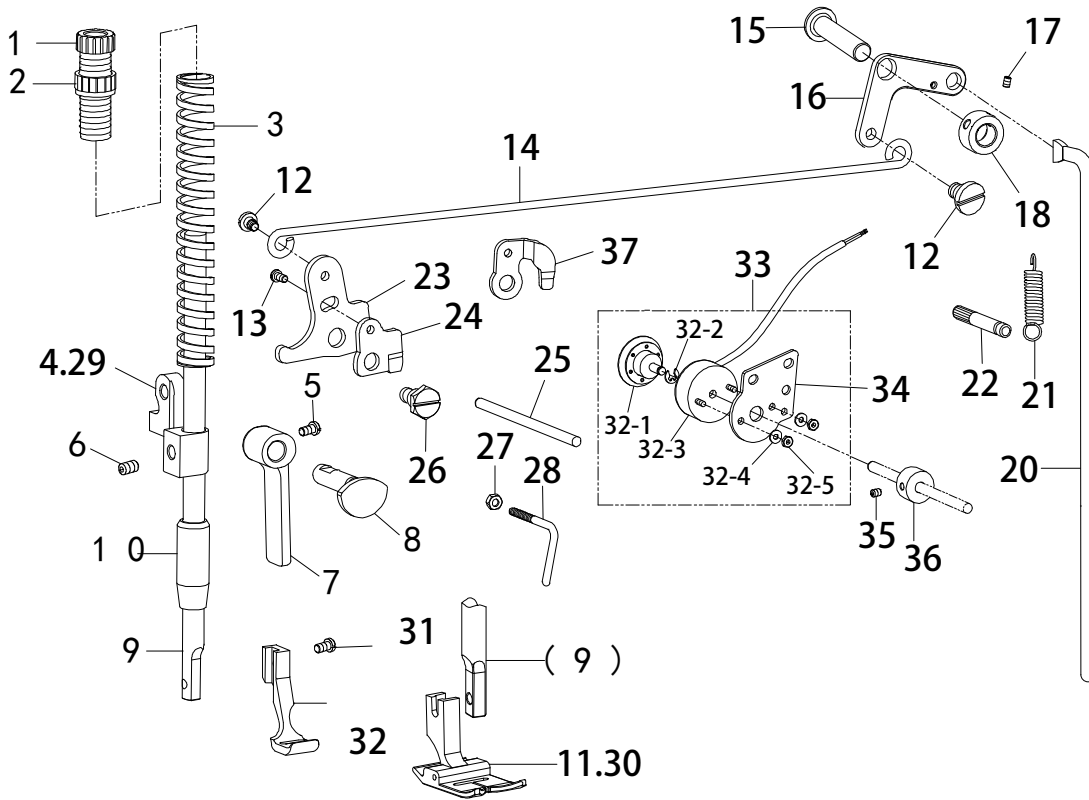

7. 多点摆针机构/3&4 points mechanism

(1653D&1654D&2653D&2654D)

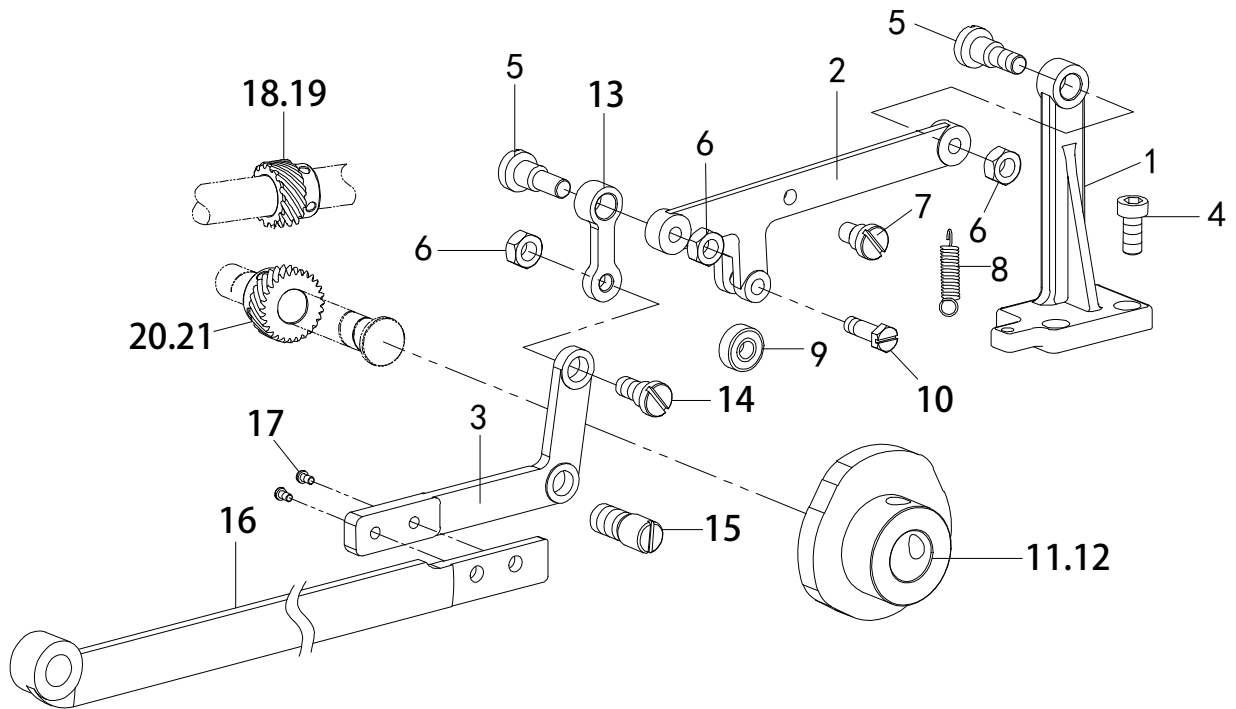

6. 抬压脚机构/Presser foot mechanism

序号 No.	图号 Part No.	名称	DESCRIPTION	数量 QTY	备注Remark
1	16526-001	调压螺丝	Adjusting screw	1	
2	16526-002	调压螺母	Nut	1	
3	16526-003	压簧	Spring, compression	1	
4	16526-004	压杆导架	Guide bracket	1	
5	16526-005	螺丝 1/4-40 L=8	Screw 1/4-40 L=8	1	
6	16526-006	螺丝 15/64-28 L=8	Screw 15/64-28 L=8	1	
7	16526-007	抬压扳手	Presser bar lifter	1	
8	16526-008	压脚扳手凸轮部件	Lifter crank	1	
9	16526-009	压杆	Presser bar	1	
10	16526-010	压杆下套	Bush	1	
11	16526-011	内压脚	Presser foot ,inside	1	
12	16526-012	螺丝 3/16-28 L=8.5	Screw 3/16-28 L=8.5	2	
13	16526-013	螺丝 11/64-40 L=6.5	Screw 11/64-40 L=6.5	1	
14	16526-014	抬压脚拉杆	Collecting rod	1	
15	16526-015	后杠杆轴	Pin	1	
16	16526-016	抬压脚后杠杆	Lever	1	
17	16526-017	挡圈	Collar	1	
18	16526-018	螺丝 11/64-40 L=4	Screw 11/64-40 L=4	2	
19	16526-019	螺丝 9/64-40 L=7	Screw 9/64-40 L=7	2	
20	16526-020	抬压脚顶杆	Knee lifter bar	1	
21	16526-021	复位拉簧	Spring	1	
22	16526-022	拉簧销	Spring pin	1	
23	16526-023	膝控提升杠杆 (左)	Lifter lever	1	
24	16526-024	松线凸轮	Guide plate	1	
25	16526-025	夹线松线杆	Tension release stud	1	
26	16526-026	段螺丝 15/64-28 L=7.5	Screw SM15/64-28 L=7.5	1	
27	16526-027	螺母 9/64-40 L=3	Nut 9/64-40 L=3	1	
28	16526-028	沙拉过线	Arm thread guide C	1	
29	26526-029	压杆导架	Guide bracket	1	01#
30	16526-030	活压脚部件	Presser foot asm.	1	
31	26526-031	压杆	Presser bar	1	01#
32	26526-032	螺丝3/16-28 L=8	Screw 3/16-28 L=8	2	01#
33	16526-033	松线电磁铁组件	Loose wire electromagnet asm.	1	02#
33-1	16526-034	卡簧 E4	E4	1	02#
33-2	16526-035	垫片	Gaskets	2	02#
33-3	16526-036	螺母M3	Nut 3	2	02#
34	16526-037	松线电磁铁安装板	Mounting Plate	1	02#
35	16526-038	螺丝M4 L=5	M4 L=5	2	02#
36	16526-039	松线挡圈	Collar	1	02#

01#:For 2652D;2653D;2654D

02#:For 2652D;2653D;2654D

7. 多点摆针机构/3&4 points mechanism(FOR 1653D, 1654D, 2653D, 2654D)

序号 No.	图号 Part No.	名称	DESCRIPTION	数量 QTY	备注Remark
1	16527-001	靠轮杆座	Rod seat.	1	
2	16527-002	螺丝 M6 L=12	Screw M6 L=12	2	
3	16527-003	段螺丝 3/16-32	Screw SM3/16-32	2	
4	16527-004	螺母 3/16-32	Nut SM3/16-32	2	
5	16527-005	靠轮杆	Bend the wheel.	1	
6	16527-006	活动连接杆	Connecting rod	1	
7	16527-007	摆针连杆	Feed dog fork	1	
8	16527-008	段螺丝 3/16-32	Screw SM3/16-32	1	
9	16527-009	滚珠轴承	Ball bearing	1	
10	16527-010	段螺丝 M4-0.75 L=6	Screw M4-0.75 L=6	1	
11	16527-011	段螺丝 3/16-28	Screw SM3/16-28	1	
12	16527-012	拉簧	Spring	1	
13	16527-013	滑块销	Screw 9/32-28	1	
14	16527-014	3点式摆针传动偏心轮	3 needle eccentric wheel	1	
15	16527-015	4点式摆针传动偏心轮	4 needle eccentric wheel	1	
16	16527-016	螺丝 M4 L=10	Screw M4 L=10	2	
17	16527-017	摆针传动连杆	Feed dog fork	1	
18	16527-018	3点摆针传动齿轮 (上)	3 Bevel gear(upper)	1	
19	16527-019	4点摆针传动齿轮 (上)	4 Bevel gear(upper)	1	
20	16527-020	3点摆针传动齿轮 (下)	3 Bevel gear(down)	1	
21	16527-021	4点摆针传动齿轮 (下)	4 Bevel gear(down)	1	

8. 上送料机构/Feed mechanism For (2652D、2653D、2654D)

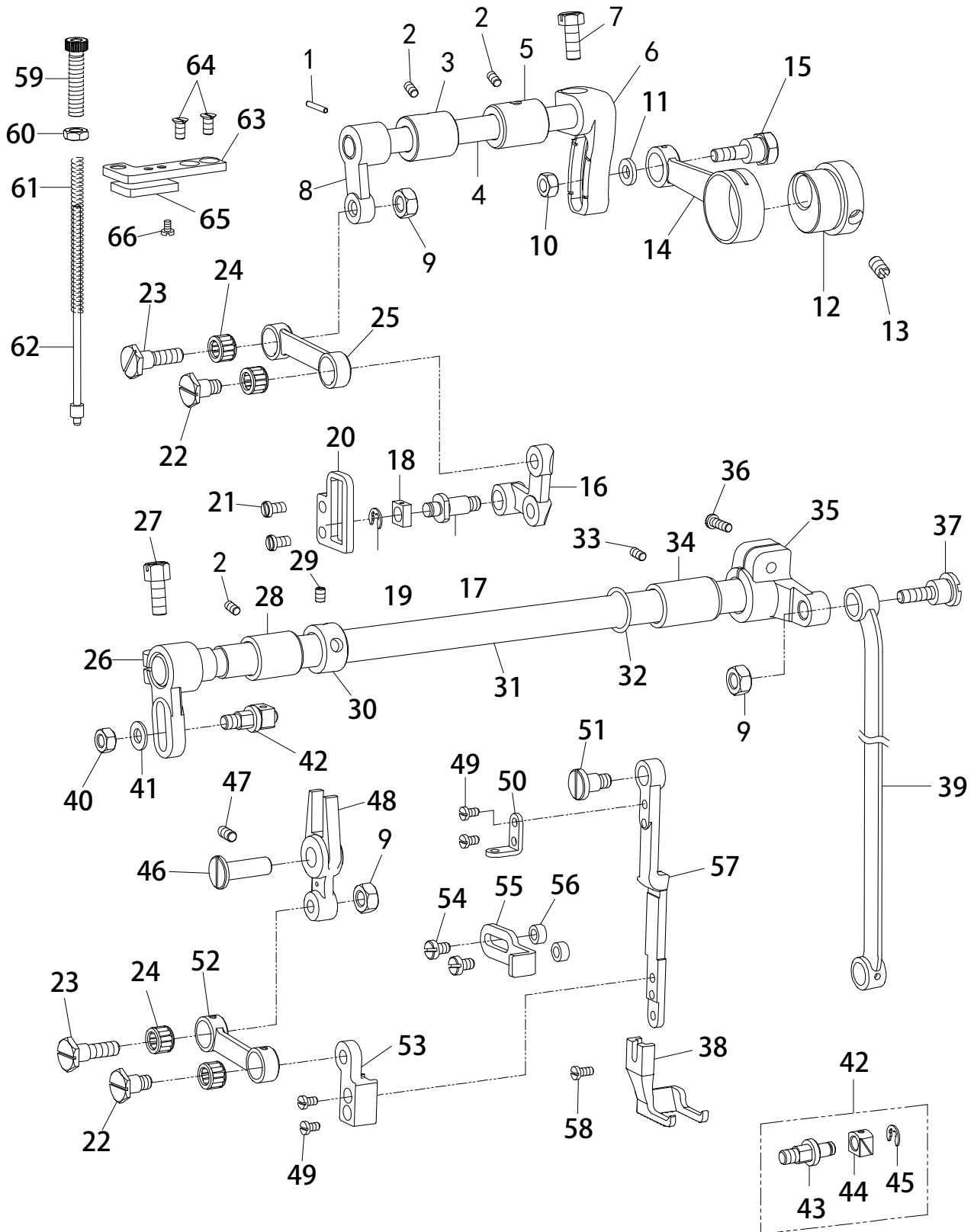

8. 上送料机构/Upper feed mechanism(FOR 2652D、2653D、2654D)

序号 No.	图号 Part No.	名称	DESCRIPTION	数量 QTY	备注Remark
1	26528-001	圆锥销	Pin	1	01#
2	26528-002	螺丝 15/64-28 L=6	Screw 15/64-28 L=6	3	01#
3	26528-003	摆动提升轴套A	Bush, A	1	01#
4	26528-004	压脚升降轴	Feed lifting shaft	1	01#
5	26528-005	摆动提升轴套B	Bush, B	1	01#
6	26528-006	偏心轮连接调节曲柄	Feed arm	1	01#
7	26528-007	螺丝 1/4-24 L=16	Screw 1/4-24 L=16	1	01#
8	26528-008	压脚升降前曲柄	Feed lifting arm crank, L	1	01#
9	26528-009	螺母	Nut 1/4-40	3	01#
10	26528-010	螺母 M6-0.75	Nut M6-0.75	1	01#
11	26528-011	垫片W5*10*1	W5*10*1 Washer	1	01#
12	26528-012	偏心轮	Eccentric wheel	1	01#
13	26528-013	螺钉 1/4-40 L=7	Screw SM1/4-40 L=7	2	01#
14	26528-014	偏心轮连杆	Connecting rod	1	01#
15	26528-015	段螺丝	Screw	1	01#
16	26528-016	压脚送料曲柄	Feed lever	1	01#
17	26528-017	段螺丝	Screw	1	01#
18	26528-018	滑块	Slide block	1	01#
19	26528-019	卡簧 E5	E5	1	01#
20	26528-020	压杆提升导位板	Lever guide	1	01#
21	26528-021	螺丝 11/64-40 L=7	Screw 11/64-40 L=7	2	01#
22	26528-022	段螺丝 1/4-40	Screw SM1/4-40	1	01#
23	26528-023	段螺丝 1/4-41	Screw SM1/4-40	1	01#
24	26528-024	滚针轴承	Needle bearing	4	01#
25	26528-025	外压提升连杆	Link	1	01#
26	26528-026	外压摆动曲柄左	Crank	1	01#
27	26528-027	螺丝 1/4-24 L=16	Screw 1/4-24 L=16	1	01#
28	26528-028	压脚摆动轴左轴套	Bush, L	1	01#
29	26528-029	螺丝 1/4-40 L=5	Screw 1/4-40 L=5	2	01#
30	26528-030	挡圈	Collar	1	01#
31	26528-031	压脚摆动轴	Upper feed shaft	1	01#
32	26528-032	O型圈	O ring	1	01#
33	26528-033	螺丝 15/64-28 L=6	Screw 15/64-28 L=6	1	01#
34	26528-034	压脚摆动轴右轴套	Bush, M	1	01#
35	26528-035	压脚摆动右曲柄	Feed lifting arm crank, R	1	01#
36	26528-036	螺丝 15/64-28 L=15	Screw SM15/64-28 L=15	1	01#
37	26528-037	连杆螺丝	Screw 1/4-40	1	01#
38	26528-038	摆压脚	Walking foot	1	01#
39	26528-039	摆压脚大连杆	Connecting rod	1	01#
40	26528-040	螺母 M6-1	Nut M6-1	1	01#
41	26528-041	垫片W6.5	W6.5	1	01#
42	26528-042	摆压脚同步调节器组件	Roller shaft assy.	1	01#
43	26528-043	提升压脚变动曲柄轴	Pin	1	01#
44	26528-044	滑块	Slide block	1	01#
45	26528-045	卡簧 E5	E5 Snap ring	1	01#
46	26528-046	摆压脚叉形杆销	Pin	1	01#
47	26528-047	螺丝 M5 L=6	M5 L=6	1	01#
48	26528-048	摆压脚叉形杆	Crank	1	01#
49	26528-049	螺丝 9/64-40 L=7	Screw 9/64-40 L=7	4	01#
50	26528-050	摆压脚导柱板	Plart	1	01#
51	26528-051	段螺丝 1/4-40	Screw 1/4-40	1	01#
52	26528-052	摆压脚连杆	Link	1	01#
53	26528-053	摆压脚杆座	Clamper	1	01#
54	26528-054	螺丝 11/64-40 L=12	Screw SM11/64-40 L=12	2	01#
55	26528-055	压脚连杆压板	Block	1	01#
56	26528-056	摆压脚杆压板垫片	Collar	2	01#
57	26528-057	摆压脚杆	Connecting rod	1	01#
58	26528-058	摆压脚叉形杆	Lever	1	01#
59	26528-059	摆压脚调压螺丝	Screw	1	01#
60	26528-060	摆压脚调压螺母	Nut	1	01#
61	26528-061	摆压脚调压杆弹簧	Spring compression	1	01#
62	26528-062	调压杆弹簧导柱	Guide shaft	1	01#
63	26528-063	摆压脚调压螺钉架	Bracket	1	01#
64	26528-064	螺丝11/64-40 L=7	Screw 11/64-40 L=7	2	01#
65	26528-065	羊毛毡	Wool felt	1	01#
66	26528-066	螺丝9/64-40 L=5	Screw 9/64-40 L=5	1	01#

01#:For 2652D;2653D;2654D

19. 立柱机构/Poster bend mechanism

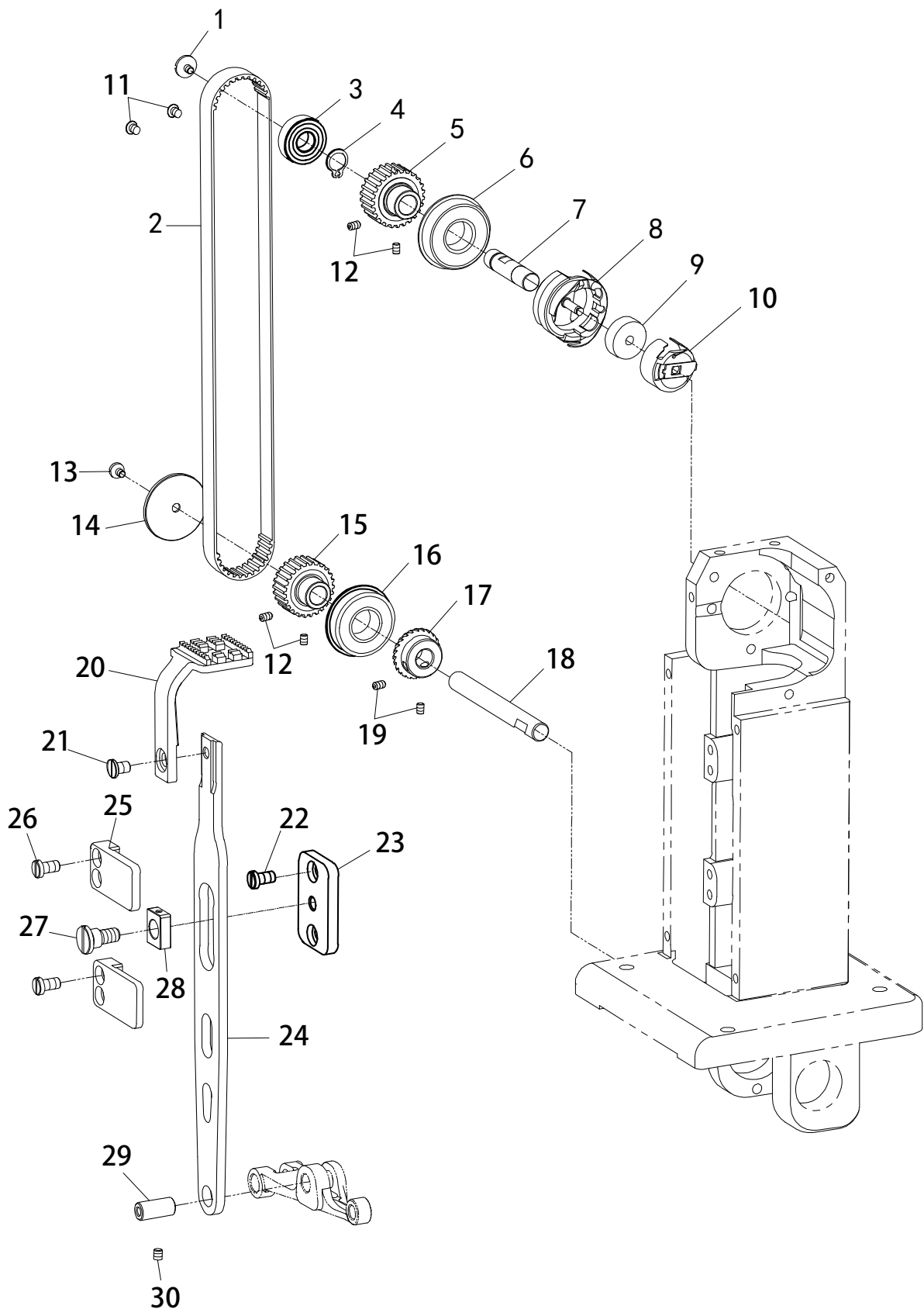

9. 立柱机构/Poster bend mechanism

序号 No.	图号 Part No.	名称	DESCRIPTION	数量 QTY	备注Remark
1	16529-001	L螺丝 9/64-40 L=4.8	End screw left 9/64-40 L=4.8	1	
2	16529-002	同步带	Timing belt	1	
3	16529-003	轴承	bearing	1	
4	16529-004	卡簧	circlip	1	
5	16529-005	同步带轮	Pulley	1	
6	16529-006	轴承	bearing	1	
7	16529-007	梭轴	Hook shaft	1	
8	16529-008	旋梭	Hook	1	
9	16529-009	梭芯	Bobbin	1	
10	16529-010	梭壳	Bobbin case ASM.	1	
11	16529-011	螺丝 11/64-40 L=6	Screw 11/64-40 L=6	4	
12	16529-012	螺丝 11/64-40 L=5	Screw 11/64-40 L=5	4	
13	16529-013	螺丝 11/64-40 L=6	Screw 11/64-40 L=6	1	
14	16529-014	挡板	baffle	1	
15	16529-015	同步带轮	Pulley	1	
16	16529-016	轴承	bearing	1	
17	16529-017	齿轮	Gear	1	
18	16529-018	转换轴	Conversion axis	1	
19	16529-019	螺丝 11/64-40 L=5	Screw 11/64-40 L=5	2	
20	16529-020	送布牙	Feed dog	1	
21	16529-021	螺丝 11/64-40 L=6	Screw 11/64-40 L=6	1	
22	16529-022	螺丝 11/64-40 L=8	Screw 11/64-40 L=8	2	
23	16529-023	支架板	Bracket plate	1	
24	16529-024	送料摆杆	Shipping fee	1	
25	16529-025	摆杆压板	Swing lever pressure plate	1	
26	16529-026	螺丝 11/64-40 L=8	Screw 11/64-40 L=8	4	
27	16529-027	台阶螺丝	Axial screw	1	
28	16529-028	滑块	Slider	1	
29	16529-029	送料摆杆销	Pin	1	
30	16529-030	螺丝 11/64-40 L=6	Screw 11/64-40 L=6	1	

10. 自动抬压脚机构/ components

For(1652D-2、2652D-2)

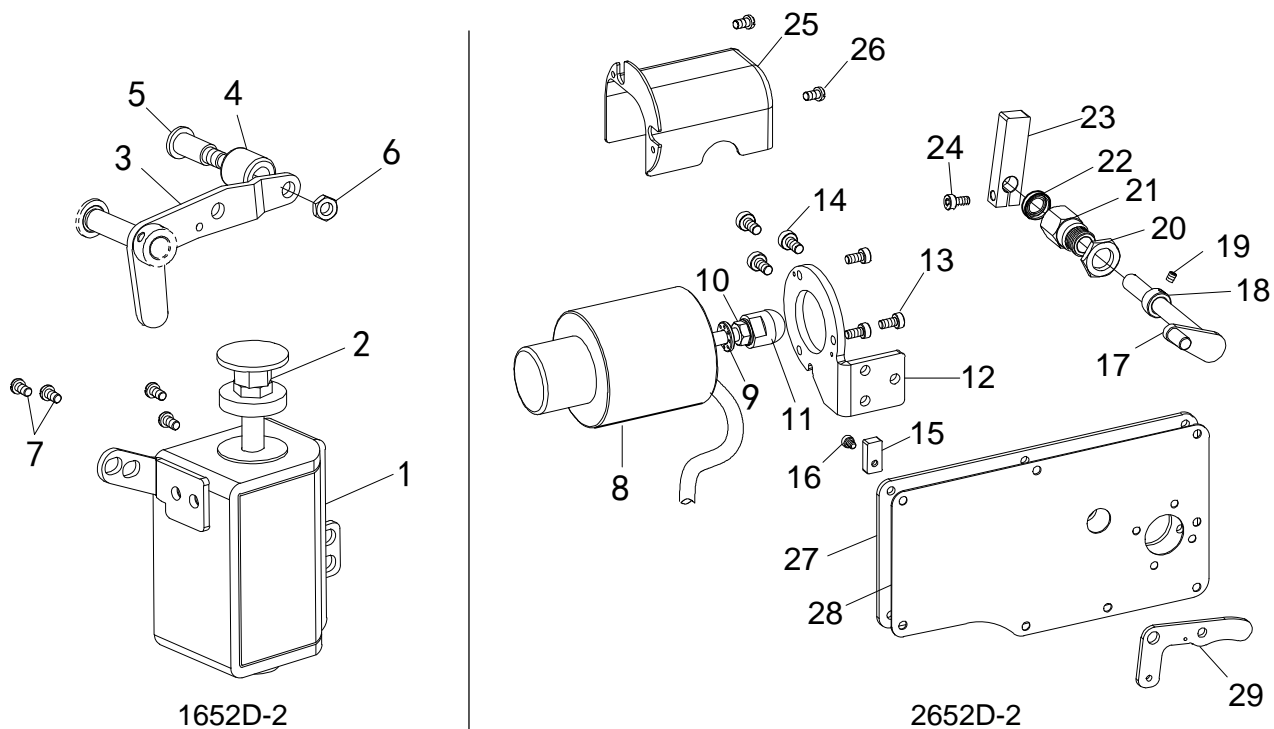

11. 自动倒送料、开关组件/Automatic reverse feed components

For(1652D-2、2652D-2)

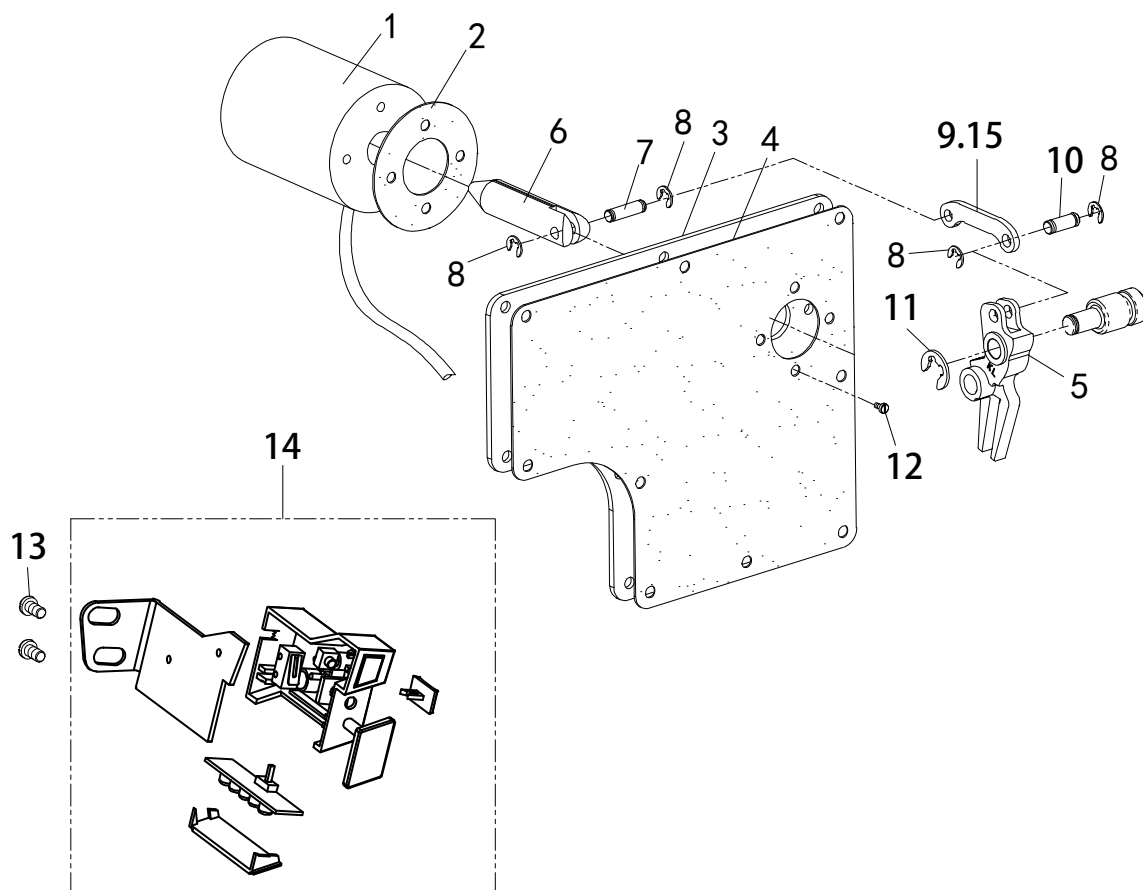

10. 自动抬压脚/Driver components

序号 No.	图号 Part No.	名称	DESCRIPTION	数量 QTY	备注Remark
1	1652A-001	抬压脚电磁铁	Electromagnet asm.	1	01#
2	1652A-002	顶帽	Top head	1	01#
3	1652A-003	膝控右杠杆	Lifting lever link	1	01#
4	1652A-004	橡胶圈	Rubber ring	1	01#
5	1652A-005	台阶螺丝	Screw 1/4-28	1	01#
6	1652A-006	螺母 1/4-28	Nut 1/4-28	1	01#
7	1652A-007	螺丝3/16-28 L=8	Screw 3/16-28 L=8	4	01#
8	1652A-008	电磁铁	Electromagnet	1	02#
9	1652A-009	缓冲垫	Cushion	1	02#
10	1652A-010	螺母	Nut	1	02#
11	1652A-011	顶头	Putter	1	02#
12	1652A-012	支架	Bracket	1	02#
13	1652A-013	螺丝M5 L=12	Screw M5 L=12	3	02#
14	1652A-014	螺丝M6 L=10	Screw M6 L=10	3	02#
15	1652A-015	垫块	Spacer	1	02#
16	1652A-016	螺丝M4 L=5	Screw M4 L=5	1	02#
17	1652A-017	转轴	Drive shaft	1	02#
18	1652A-018	挡圈	Retaining ring	1	02#
19	1652A-019	螺丝 11/64-40 L=4	Screw 11/64-40 L=4	1	02#
20	1652A-020	螺母 M16	Nut M16	1	02#
21	1652A-021	轴套	Bushing	1	02#
22	1652A-022	密封圈	Sealing ring	1	02#
23	1652A-023	曲柄	Crank	1	02#
24	1652A-024	螺丝M5 L=12	Screw M5 L=12	1	02#
25	1652A-025	罩壳	Cover	1	02#
26	1652A-026	螺丝M3 L=5	Screw M3 L=5	2	02#
27	1652A-027	后盖板	Side plate	1	02#
28	1652A-028	后盖板垫	Gasket	1	02#
29	1652A-029	膝控右杠杆	Lifting lever link	1	02#

01#:For 1652D-2;1653D-2;1654D-2

02#:For 2652D-2;2653D-2;2654D-2

11. 自动倒缝开关组件 /Driver components

序号 No.	图号 Part No.	名称	DESCRIPTION	数量 QTY	备注Remark
1	1652B-001	倒缝电磁铁	B/T Solenoid Ass'y	1	01#, 02#
2	1652B-002	防油垫	Gasket for B/T Solenoid	1	01#, 02#
3	1652B-003	后窗板	Side plate	1	01#
4	1652B-004	后窗板垫	Gasket	1	01#
5	1652B-005	送料调节器	Feed regulator	1	01#, 02#
6	1652B-006	电磁铁芯	Electromagnet core	1	01#, 02#
7	1652B-007	销	Pin	1	01#, 02#
8	1652B-008	卡簧 E4	E4	4	01#, 02#
9	1652B-009	倒缝拉杆	Solenoid crank	1	01#
10	1652B-010	销	Pin	1	01#, 02#
11	1652B-011	卡簧E8	E8	1	01#, 02#
12	1652B-012	螺丝 11/64-40 L=10	Screw 11/64-40 L=10	4	01#, 02#
13	1652B-013	螺丝3/16-28 L=6	Screw 3/16-28 L=6	2	01#, 02#
14	1652B-014	灯组倒缝开关	Auto reverse feed switch asm	1	01#, 02#
15	1652B-015	倒缝拉杆	Solenoid crank	1	02#

01#:For 1652D-2;1653D-2;1654D-2

02#:For 2652D-2;2653D-2;2654D-2

12. 电控部件/Driver components

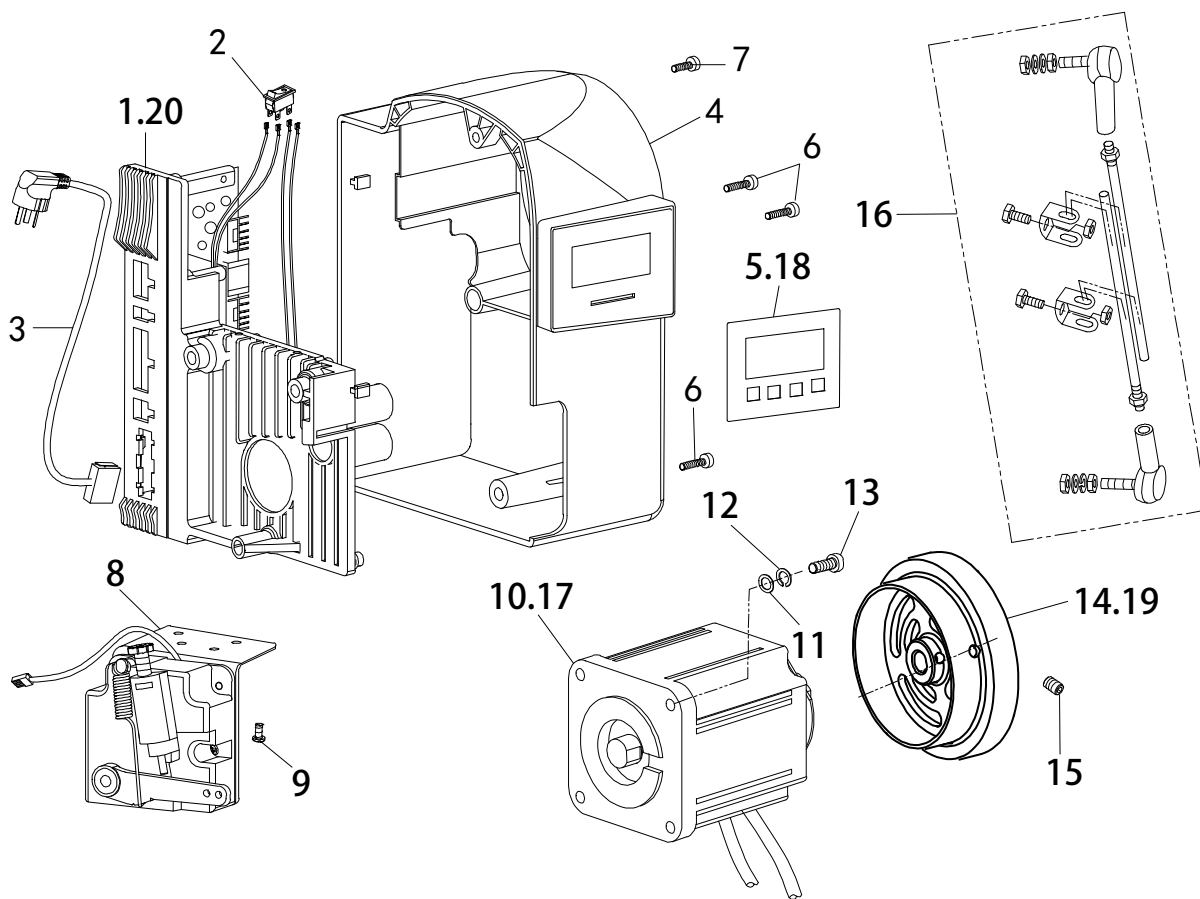

14. 供油机构/Oil lubrication mechanism

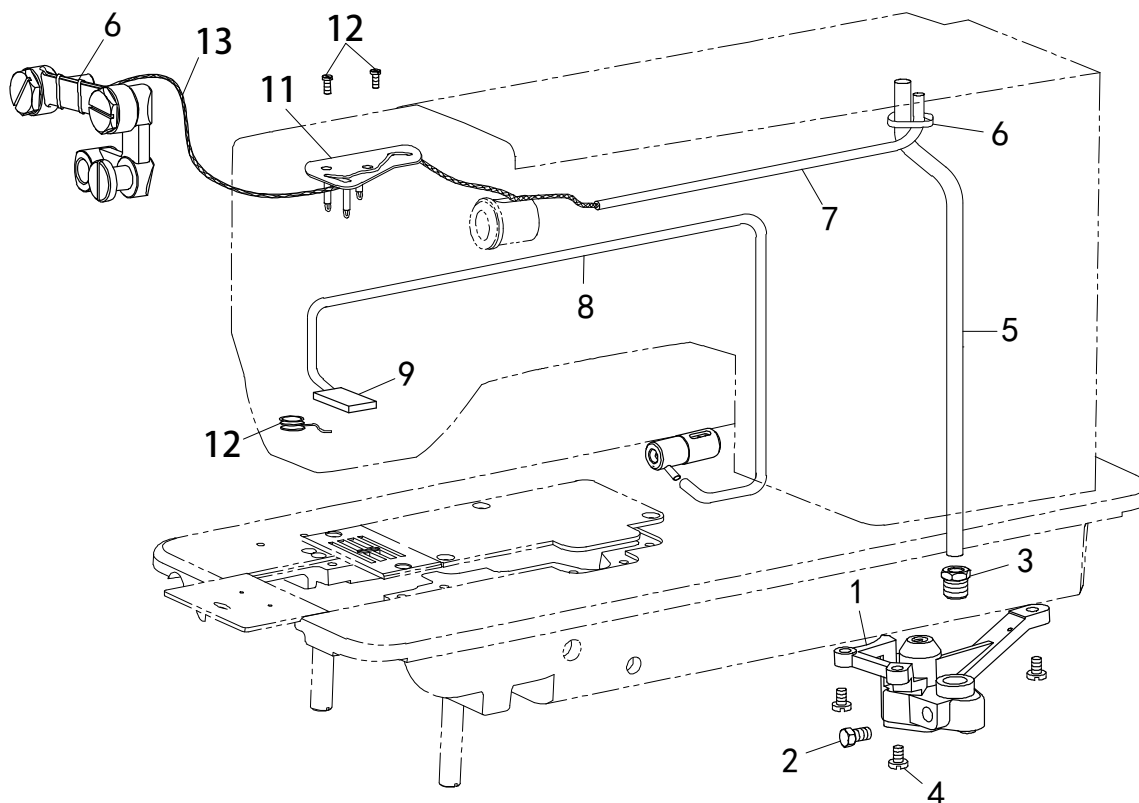

12. 电控部件/Driver components

序号 No.	图号 Part No.	名称	DESCRIPTION	数量 QTY	备注Remark
1	1652C-001	电控组件	Control asm	1	
2	1652C-002	电源开关	Power switch	1	
3	1652C-003	电源线	Power line	1	
4	1652C-004	电控罩	Control cover	1	
5	1652C-005	操作面板	Face plate	1	
6	1652C-006	螺丝M5 L=35	Screw M5 L=35	3	
7	1652C-007	螺丝M5 L=20	Screw M5 L=20	2	
8	1652C-008	脚踏控速器	Thread asm	1	
9	1652C-009	螺钉	Screw	3	
10	1652C-010	AC伺服马达550W	AC cervo motor 550W	1	
11	1652C-011	垫片	Washer	4	
12	1652C-012	弹性垫片	Spring washer	4	
13	1652C-013	螺丝M6 L=12	Screw M6 L=12	4	
14	1652C-014	手轮	Hand wheel	1	
15	1652C-015	螺丝 15/64-28 L=10	Screw 15/64-28 L=10	2	
16	1652C-016	拉杆组件	Live festival balllink asm	1	
17	2652C-017	AC伺服马达750W	AC cervo motor 750W	1	02#
18	1652C-018	操作面板	Face plate	1	02#
19	2652C-019	手轮	Hand wheel	1	02#
20	2652C-020	电控组件	Control asm	1	02#

02#:For 2652D;2653D;2654D

13. 供油机构/Oil lubrication mechanism

序号 No.	图号 Part No.	名称	DESCRIPTION	数量 QTY	备注Remark
1	1652D-001	油泵组件	Oil pump	1	
2	1652D-002	螺丝11/32-28 L=5	Screw SM11/32-28 L=5	1	
3	1652D-003	螺丝11/32-28 L=5	Screw SM11/32-28 L=5	1	
4	1652D-004	螺丝 11/64-40 L=13	Screw 11/64-40 L=13	3	
5	1652D-005	上油管	Oil tube	1	
6	1652D-006	扎带	Tie	3	
7	1652D-007	油管	Tube assy.	1	
8	1652D-008	回油管	Tube assy.	1	
9	1652D-009	羊毛毡	Wool felt	1	
10	1652D-010	羊毛毡压簧	Spring	1	
11	1652D-011	油泵体盖板组件	Setting plate	1	
12	1652D-012	螺丝 9/64-40 L=13	Screw 9/64-40 L=13	2	
13	1652D-013	油绳	Oil tip	2	

14. 附件/Assessories

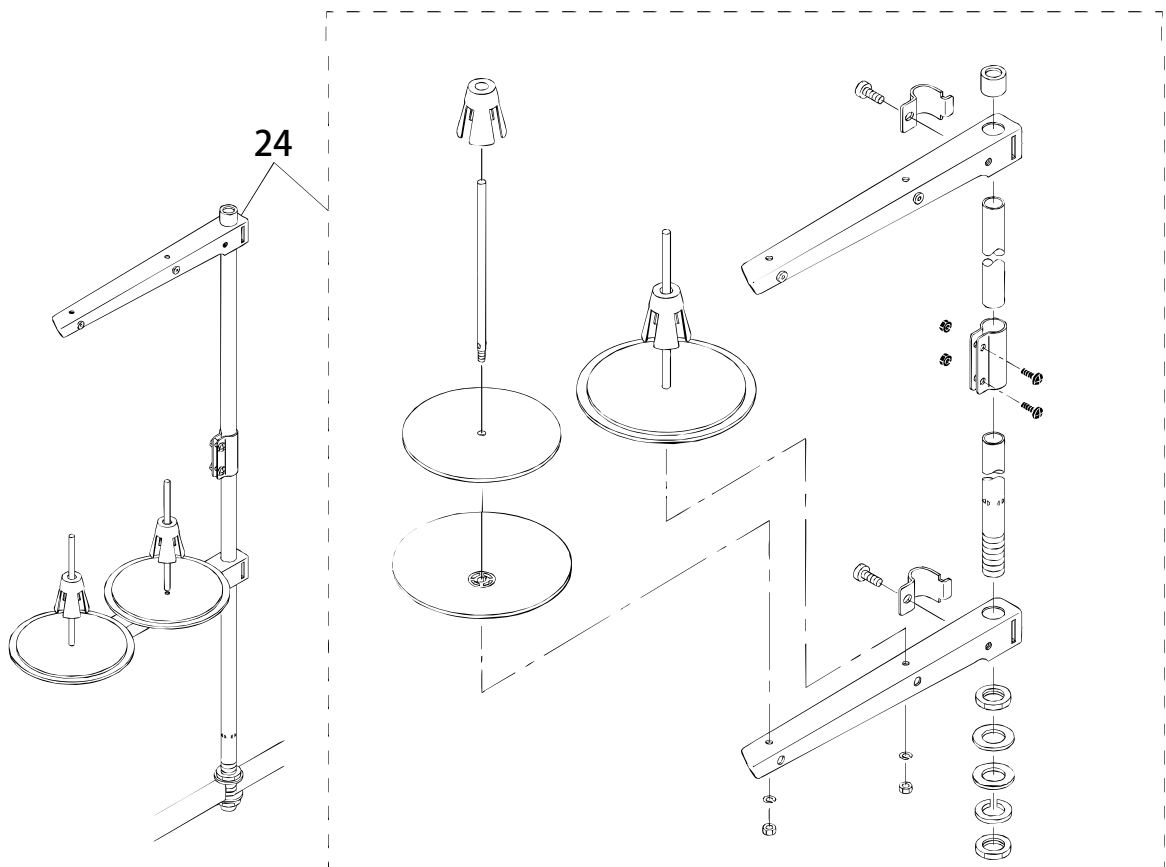
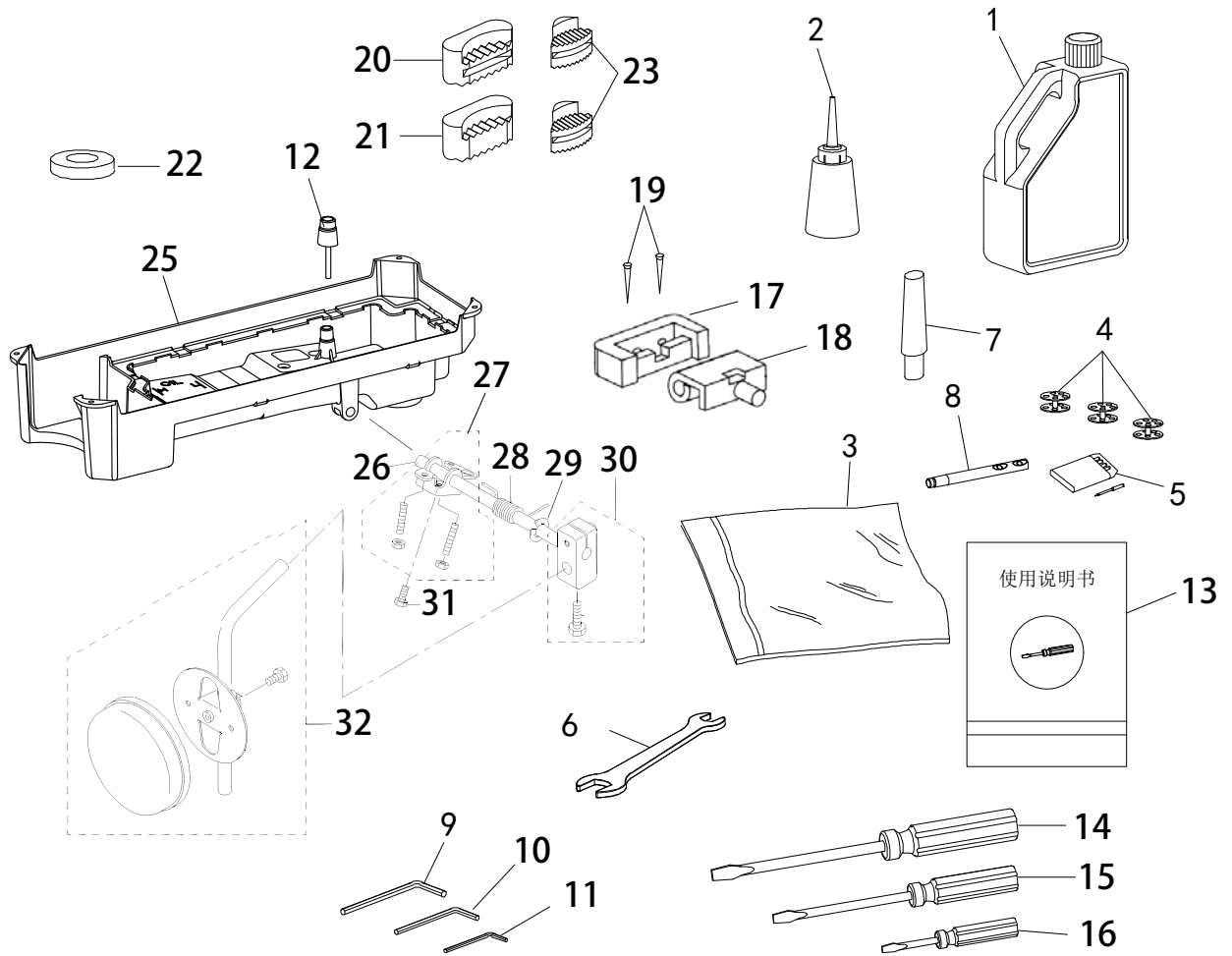

14. 附件/Assessories

序号 No.	图号 Part No.	名称	DESCRIPTION	数量 QTY	备注Remark
1	1652D-001	油壶	Oil tank	1	
2	1652D-002	注油壶	Oil pot	1	
3	1652D-003	机头罩	Accessory bag	1	
4	1652D-004	梭芯	Bobbin	3	
5	1652D-005	机针包 DPX17 18#	Needle	1	
6	1652D-006	扳手	Wrench	1	
7	1652D-007	机头撑杆	Head rest	1	
8	1652D-008	过线柱	Needle thread guide pin	1	
9	1652D-009	5MM六角扳手	Wrench, 5	1	
10	1652D-010	4MM六角扳手	Wrench, 4	1	
11	1652D-011	3MM六角扳手	Wrench, 3	1	
12	1652D-012	Z型螺丝刀	Z-shaped screwdriver	1	
13	1652D-013	说明书	Instruction	1	
14	1652D-014	大起子	Screw driver, L	1	
15	1652D-015	中起子	Screw driver, M	1	
16	1652D-016	小起子	Screw driver, S	1	
17	1652D-017	机头连接钩座	Head connecting hook socket	2	
18	1652D-018	机头连接钩部件	Head connecting hook	2	
19	1652D-019	机头连接钩座钉	Head connecting hook nail	4	
20	1652D-020	防震垫右	Quakeproof washer R	1	
21	1652D-021	防震垫左	Quakeproof washer L	1	
22	1652D-022	油盘磁铁	Oil reservoir magnrt	1	
23	1652D-023	三角垫	Trigonometric washer	2	
24	1652D-024	二线架组件	Thread stand assy.	1	
25	1652D-025	油盘	Oil reservoir asm	1	
26	1652D-026	抬压脚轴	Knee pressing shaft	1	
27	1652D-027	抬牙脚双向曲柄组件	crank of lifting presser fot asm	1	
28	1652D-028	双向曲柄扭簧	Torsion spring	1	
29	1652D-029	开口挡圈	Snap ring	1	
30	1652D-030	抬压脚操纵杆接头	Bracket	1	
31	1652D-031	双向曲柄螺丝	Screw	1	
32	1652D-032	操纵杆部件	Knee pressing plate asm	1	

