

# GLOBAL

GLOBALSEW.COM

# HP-20

## user manual



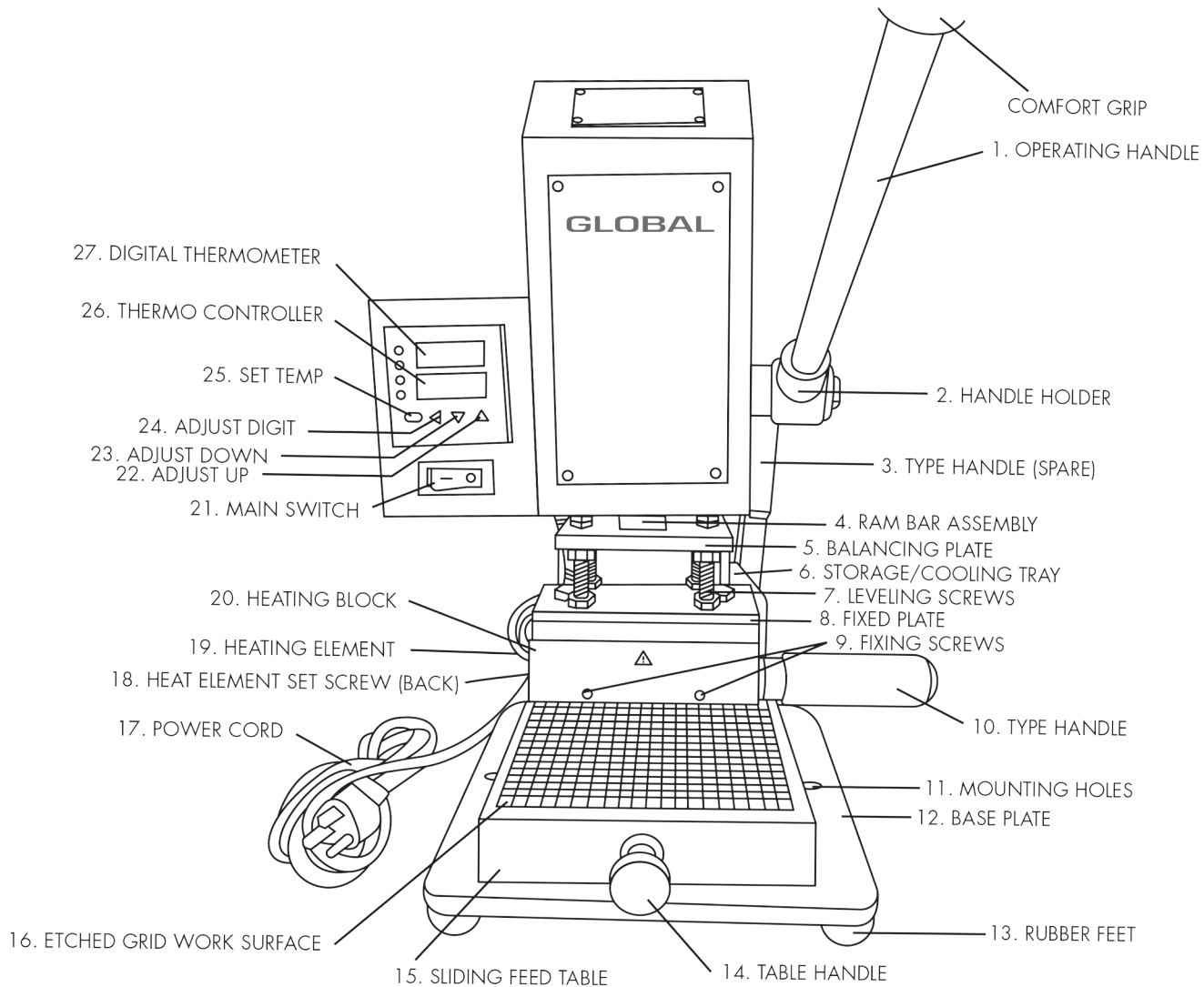

### NAME OF PART AND FUNCTION

1. OPERATING HANDLE WITH COMFORT GRIP: When pulled down, applies pressure to the type and the material to accomplish the printing/embossing process.
2. HANDLE HOLDER: Holding the operating handle.
3. TYPE HOLDER WITH SILICONE HANDLE (Spare)
4. RAM BAR ASSEMBLY: Raises and lowers the heating block.
5. BALANCING PLATE: For balancing and leveling the type holder to the required level and achieve the best performance.
6. STORAGE/COOLING TRAY: A storage location for type holders when not in use and a safe place to cool down prior to changing type.
7. LEVELING SCREWS (4): Used to balance and adjust the level of the balancing plate.
8. FIXED PLATE: Attaching the balancing plate and heating block
9. FIXING SCREWS (2): Tightens or loosens the type holder to the heating block.
10. TYPE HOLDER WITH SILICONE HANDLE: Holds the type setting.
11. MOUNTING HOLES (2): To secure the machine to a sturdy work surface for safe operation.
12. BASE PLATE: Provides a stable platform for the machine.
13. RUBBER FEET (4)
14. TABLE HANDLE: For sliding the sliding the feed table.
15. SLIDING FEED TABLE: A table on the machine for mounting the project, slides manually in/out for ease of use.
16. ETCHED GRID WORK SURFACE: For easy alignment.
17. 220V/ 230V POWER CORD
18. SET SCREW FOR HEAT ELEMENT: Secures the heating element inside the heating block.
19. HEAT ELEMENT: Generates the necessary heat for the machine to perform stamping/embossing.
20. HEATING BLOCK: Holds the heating element inside to generate heat required to hot foil stamp and embossing.
21. MAIN SWITCH: Power on/off switch.
22. ADJUST TEMPERATURE UP
23. ADJUST TEMPERATURE DOWN
24. ADJUST DIGIT
25. SET TEMPERATURE
26. THERMO CONTROLLER (SET OPERATING TEMPERATURE): Adjusts temperature of the heating block to suit stamping requirements.
27. DIGITAL THERMOMETER: Actual Temperature

## GETTING STARTED

Reference page numbers have been included in this section to make finding appropriate information easier.

1. Read this Instruction Manual from cover to cover.
2. Unpack and Inspect all equipment and accessories.
3. Place the Heat Imprinter Machine on a table capable of supporting the weight.
4. Mount Imprinter to table.
5. Install Operating Handle.
6. Use extra caution when opening the Brass Imprint type, as the type is fragile and the characters can easily fall out of the package. When first opening the case use special care to keep the type in order. It can take an extensive amount of time to resort the type if it should get mixed up. Also, be aware that the amount of type you will receive per character will vary depending on its use in language (For example; you will receive more e's than z's).
7. Ensure the Main Power Switch is in the OFF position.
8. Plug the Heat Imprinter into a standard electrical outlet.
9. Setup Type Holder: Type is set right side up and backwards with type holder handle to your left. Adjust end caps and secure type in place once type is centered on guidelines.
10. Insert type holder directly into the right side of the heating block. Secure into place with the two fixing screws on the front of the heating block.
11. Turn the main power switch to the ON position.
12. Set the digital temperature controller to 135°C. This should be a good starting point, after which you may gradually increase the temperature if needed to find the ideal setting for your application.
13. Allow 3-5 minutes for the Heat Imprinter to warm up and reach temperature.
14. Place project onto Sliding Feed Table.
15. Place foil onto project.
16. Begin stamping by pulling down on Operating Handle. Be sure your hands are clear and the project is appropriately positioned under the type. Control quality of print by varying pressure and dwell. Typical dwell is 1-2 seconds.

### ADDITIONAL HELPFUL ITEMS:

- Scissors: To cut foil.
- Double Tape: Fixture to temporarily secure project to Sliding Feed Table.
- Ruler: To measure project and for aligning placement.

### UNPACKING THE BOX

The machine is packed in the box to protect the machine from damage during transportation. Care must be taken when you are removing the machine from the box to prevent damaging the machine. Do not lift from under electronic control box attached to the left side of the machine.

### ATTACHMENTS

The following are standard accessories and tools provided and packed with the machine:

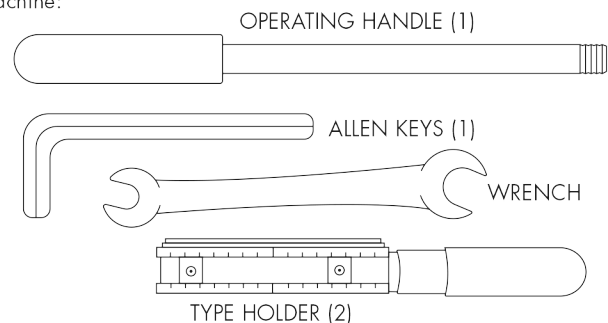

## INSTALLING THE HEAT IMPRINTER

1. Imprinter should be permanently mounted to a level, secure bench or table using the mounting holes provided. It should be at a level that allows the operator to move the Sliding Feed Table while forearms are parallel to the floor. Be sure to allow enough space around the machine for maintenance, set-up and production.

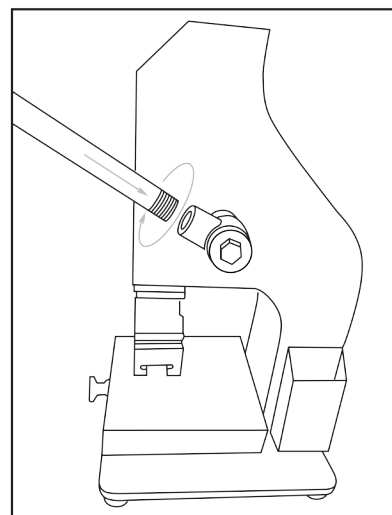
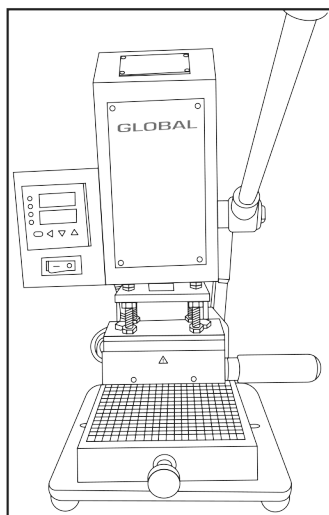

# SETTING UP

## SETTING THE TEMPERATURE

Intelligent Temperature Controller Panel Descriptions:

1. PV Display Window: Displays the actual temperature of the Heating Block.
2. SV Setting Window: Displays the set target temperature.
3. OUT Lamp:
4. Setting Key: The main function key.
5. Shift Key:
6. Numeric Reducing Key:
7. Numeric Increasing Key:

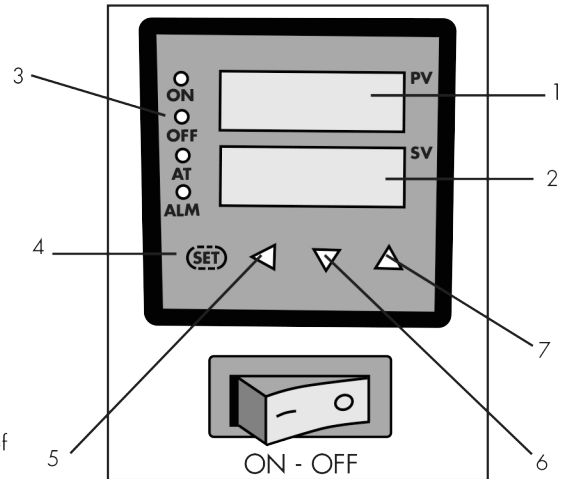

## CHANGING SET TEMPERATURE (SV), example: change set value (SV) from 0° to 200°C.

1. PV/SV Display Mode - Under the normal working display mode of the instrument, press and hold the "SET" key for 0.5 seconds to enter the setting mode and flashing digit can be modified.
2. Set SV Setting Mode - Press the shift key "◀" to move the flashing digit to the place of hundreds digit.
3. Press the "▲" up key to set the value as 200. \*Press the "▲" up key to increase the number, and press the "▼" down key to reduce the number.
4. Save Set Value - After finishing the setting, press the "SET" key to save and then the instrument will return to the PV/SV display mode.

## HOW TO SET THE TYPE

### What is Type?

Type are individual letters, numbers and symbols that get loaded into a type handle which gets placed in the heating block for imprinting. Craftool® Pro Brass Imprint Type comes in two text sizes 4.5 mm (12.75 pt.) and 6.0 mm (17 pt.). to fit the Craftool® Pro Imprinter Type Handle.

### Craftool® Imprinter Type Handle

Type Handles are used for a single line of text. Set type as illustrated with the type centered on type handle. Center of text will then be imprinted where the center line cross on the Sliding Feed Table. The Type Handle must be inserted from the right side of the Heating Block.

### Type Setting:

It is the procedure to place each piece of Type into a Chase that holds the Type together. The chase is also referred to as a Type Holder. Please rest assured that there is nothing special in setting type. As one gains experience in setting type, different ways of shorting the process will become apparent. **DO NOT SET TYPE WHILE TYPE HANDLE IS STILL HOT.**

- Place the type holder, type slot up towards you with the handle on the right side.
- Use Allen Key to loosen type locks. Slide left (outside) lock out of type holder to allow access for type.
- The type is set in correct order but facing away from you (upside-down).
- The spacers that fit between words come in different widths for customization.
- After the type setting is completed, ensure that the type is centered on the center guide line. Slide type locks to ends of type and secure in place with Allen Key.

### Installation of Type Holder

1. Loosen the Fixing Screws on the front of the Heating Block.
2. Turn the Type Holder upside down. (Type facing downward)
3. Place the Type holder into the right side of the Heating Block.
4. Ensure the Type Holder is pushed all the way in and seated against the back stop.
5. Fix the Type Holder in position by tightening the Fixing Screws on the Heating Block. **DO NOT OVER TIGHTEN.**

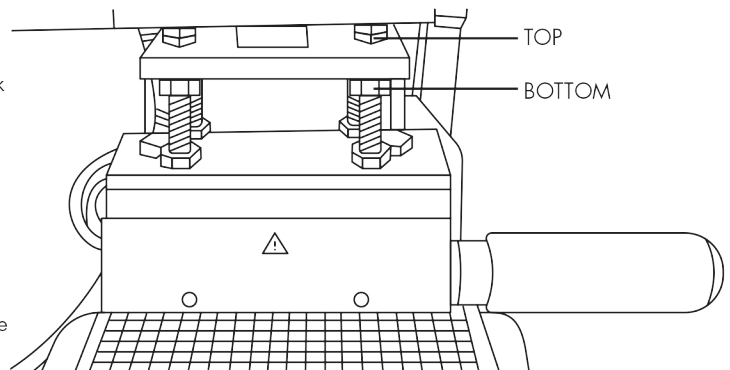

### Type Handle Leveling

Adjust the four Leveling Screws for balancing and adjusting the required level of the Balancing Plate (if needed) for perfect imprinting.

- To bring a side of the platform down, place wrench on the bottom bolt and turn the bottom bolt to the left (clockwise), about a half turn. Then, tighten the top bolt by turning to the left (clockwise).
- To bring a side of the platform up, place wrench on the top bolt and turn the top bolt to the right (counter-clockwise) about a half turn. Then, tighten the bottom bolt by turning to the right (counter-clockwise).
- The above steps may need to be repeated to achieve an even stamp.



## OPERATION

### THE ACT OF HOT STAMPING

- Cut the foil to a size that covers the area of the type. It is not necessary to be exact, just do not be short.
- Turn on the heating element and set the temperature for around 135°C. Allow time to preheat.
- Pull the table out from under the heating block and place project on table of heat imprinter. Project can be temporarily secured in place with double adhesive tape.
- Remember if you are stamping on leather, you can make a blank impression first (without foil). Next, being careful not to move the project, re-stamp the leather with foil.
- Place foil down over the project. The dull side of the foil should face down, with “shiny” side up.
- Push table back under the heating block, centering project under type.
- Bring the heated type onto the foil and project with a smooth stroke and minimal pressure for approximately 1 second, or until just after pressure is applied. Remember to use the right combination of Heat, Pressure and Dwell as discussed earlier.
- For a more professional “filled” foil imprint, repeat the foil imprinting step 5 to 6 times to fill the impression with foil.
- The thermal activated foil that is transferred melts onto the project. After stamping any item, return the handle to the up position and remove the foil piece from over the project. The process is complete. There is no drying time for foil.

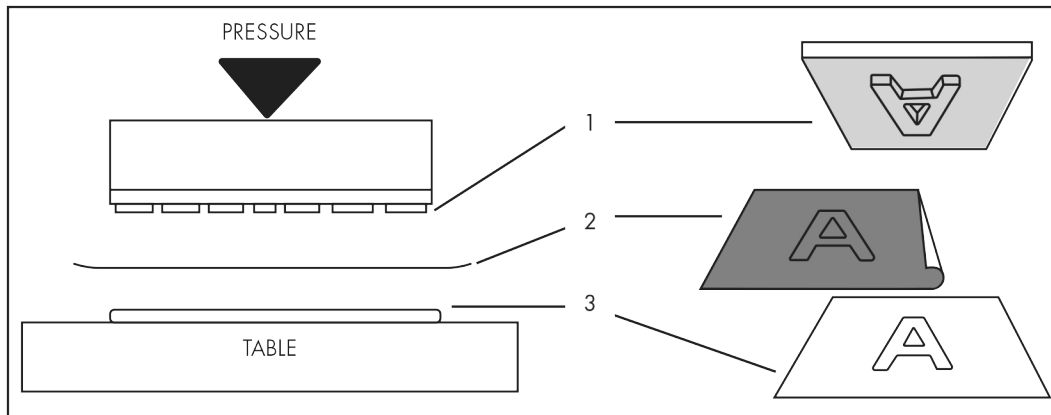

### CORRECT STAMPING PRESSURE

- To get the fine perfect imprints that are possible only with the balanced mechanism and sensitive “feel” of the Craftool® Pro Heat Imprinter. Practice stamping on scrap, applying the pressure.
- If you do not get a clear impression the first time, stamp over again – holding the handle down a little longer or with a little more pressure. If the color is still faint – the machine may be too cold.
- If the impression is blurred or smeary – you have held the handle down too long, or the machine is too hot. Switch the machine off a few seconds to reduce the heat quickly.
- Blurred impressions may be brushed clean with a soft cloth or art gum. A moistened toothpick may be used to carefully remove any excess foil between the letters.

### PROOF BEFORE FINAL IMPRINTING

Before final imprinting, always try a proof on scrap to check the following:

- Type setting.
- The heat of machine.
- Location placement on Sliding Feed Table.

If any single letter does not stamp, and the others do, it shows that the piece of type is worn or damaged – discard and replace it. Always examine the project before removing from the machine, so that you can stamp again if necessary.

<b>HOT STAMPING TROUBLESHOOTING</b>		
<b>PROBLEM</b>	<b>CAUSE</b>	<b>SOLUTION</b>
Incomplete hot stamped image	Uneven die to part contact	Reposition fixture so decorating surface is parallel to a flat die or conforms to a contoured die
	Dust particles on decorating surface	Clean surface with white cotton cloth or glove.
Over stamping of image	Too much pressure	Decrease stroke length and/or reduce machine pressure
	Die face is too hot	Reduce temperature setting
	Dwell time is too long	Reduce dwell time
Hot stamped image appears blurry	Too much pressure	Decrease stroke length and/or reduce pressure
	Die face is too hot	Reduce temperature
	Dwell time is too long	Reduce dwell time
Poor foil to part adhesion	Insufficient die surface temperature	Increase temperature setting
	Dwell time is too short	Increase dwell time
	Dust particles on decorating surface	Clean surface with white cotton cloth or glove.
	Foil stamping problem	Switch foil portion
Incomplete stamped image	Uneven die-to-part contact	Reposition fixture so that the decorating surface is in proper relationship to die.
	Foreign particles on surface	Wipe surface with white cotton cloth or glove.
	Fixture support or surface uneven	Ensure fixture is level and leather is even thickness
Edges of image are ragged or not sharp	Insufficient stamping pressure	Increase stroke length and/or pressure
	Die surface temperature too low	Increase temperature setting
	Insufficient dwell time	Increase dwell time
Poor image adhesion	Insufficient die heat	Increase temperature setting
	Foil-to-surface incompatibility	Change surface material to compatible material.

## **MAINTENANCE**

- Every time the machine is to be used, inspect machine for obvious defects and ensure machine is properly functioning. If any problem is detected, disconnect the imprinter until corrected.
- The Heat Imprinter should be kept dry, clean and free of dirt and contaminants.
- Use a premium grade of high temp grease on the main RAM if needed.

## **HEAT ELEMENT REPLACEMENT**

\*After Heating Block is cool then proceed with following steps:

1. Ensure machine is OFF, then unplug cord from outlet.
2. Using Allen Key loosen set screw on back of Heating Block next to thermostat port to release Heat Element.
3. Untwist, remove and set aside the restraining tie-down.
4. Unscrew cable clamp from machine.
5. Disconnect the black coupling on back of control box.
6. Unscrew 3 screws securing control box to imprinter.
7. Disconnect quick connect clips.
8. Pull Heat Element wires free from protective sleeve.
9. Remove Heat Element from Heating Block.
10. Connect NEW Heat Element quick connect clip to machine.
11. Place NEW Heat Element into Heating Block.
12. Place wires back inside protective sleeve.
13. Reattach to protective sleeve and mount cable clamp to machine.
14. Secure wires to ceramic washer with restraining tie-down.

2. Install the Operating Handle into the handle holder and rotate the handle clockwise until tight and secure.
3. Ensure the Main Switch is in the OFF position.
4. Insert the power plug into the correct power source and machine is ready to start.

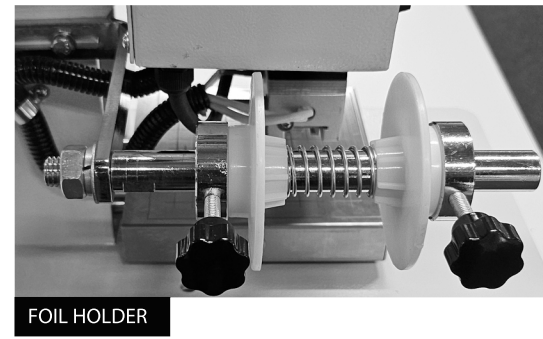

FOIL HOLDER

## PREPARATION

Before hot stamping, you need to make some preparations including type, choice of foil, and fixtures, ect.

## FOIL SELECTION

Correct selection of foil is an important factor for perfect hot stamping. There are three major points to consider:

1. **Compatibility:** The foil used must be compatible with the material to be printed.
2. **Color:** Select the correct color for your job.
3. **Cut Width:** The width of the foil should be enough to cover the image area to be imprinted. Always allow at least 1/4" (6 mm) on each side. Place down onto material "shiny" side up.

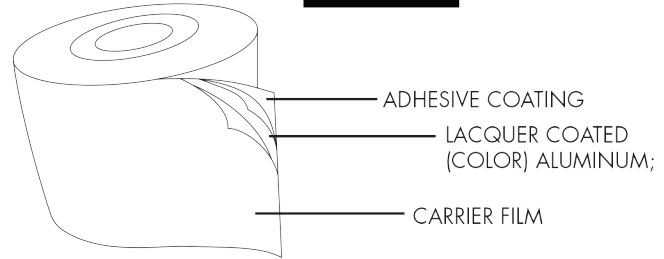

## FIXTURES

Before printing starts, you need to prepare a fixture to hold the object to be printed in the correct position.

1. **Accuracy:** The fixture should hold the object to be printed securely to allow imprinting in the exact location, repeatedly.
2. **Efficiency:** A fixture should allow quick and easy positioning of the object to be printed.
3. **Safety:** The fixture should not have any sharp points or edges that may harm the operator or material to be printed.

One of the easiest fixtures is a high-temperature resistant double adhesive tape. The tape holds material in place on the table during stamping.

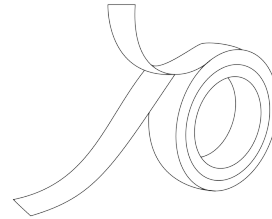

## HEAT, PRESSURE AND DWELL

The following instructions will give you the general information you will need to operate your Craftool® Pro Heat Imprinter. Always remember the 3 factors of hot stamping are: HEAT, PRESSURE and DWELL time. These are very important factors that allow you to achieve perfect stamping every time.

### HEAT

Printing temperature is controlled by a safe and reliable thermostat. When the heating block reaches the required temperature, the heater automatically shuts off and the heater indicator also shuts off. The heater indicator turns on and off during operation, maintaining the required temperature.

Before printing, turn the temperature controller to a higher temperature. The heating block needs about 15 minutes to warm up at room temperature. After the heater Indicator turns off, adjust the temperature controller to the appropriate setting.

The material to be printed and type/plate used determine the machine temperature requirements. Temperature requirements for most material falls between 100 C to 200 C. A guidance table is detailed below for your reference.

IMPRINT MATERIAL	APPLIED TEMP C
Leather	110° - 150° (135° Suggested temperature)
Paper	100° - 140°
Acrylic / Plastic / Wood	150° - 200°

Embossing on finished leather by stamping (without foil) can be done at a higher temperature around 250°C.

### PRESSURE

Pressure is controlled by the feel of the operator while pulling down on the operating handle attached to the upper right quadrant of the machine. You need to apply enough pressure to fully imprint your type into your product. The pressure needed to make a perfect imprint is actually light. Larger print areas or hard materials require more pressure. Getting the right amount of pressure is a learned "touch" or "feel".

### DWELL

Dwell time or "hold-down" time is the amount of time the hot type is in contact with the foil and the product to be printed. The user controls the dwell time by the length of time the handle is depressed. Many feel they need to apply more dwell time than they really necessary. Too long of a dwell time will "bleed" or melt the foil giving a blurred image, instead of a clean crisp imprint.

You will need to experiment with your first printed article to determine the best combination of heat, pressure and dwell.

15. Secure Heat Element in place by tightening down set screw on Heating Block. DO NOT OVER TIGHTEN.
16. Plug power cord into outlet.
17. Turn power switch ON, wait to ensure NEW Heat Element is working properly before continuing operations.

## PARTS LIST

While your Craftool® Pro Heat Imprinter is highly reliable and trouble-free, occasional parts replacement may be required due to normal wear and aging. This section contains a listing of the currently available parts for order.

SKU No.	Description
#3970-50	CP Heat Imprinter Handle
#3970-51	CP Heat Imprinter Element
#3970-15	Heat Imprint Foil 1-1/2" x 60 m (38 mm x 60 m) Gold
#3970-16	Heat Imprint Foil 1-1/2" x 60 m (38 mm x 60 m) Silver
#3970-17	Heat Imprint Foil 1-1/2" x 60 m (38 mm x 60 m) Copper
#3970-10	4.5mm Brass Imprint Set
#3970-11	6.0mm Brass Imprint Set

## SPECIFICATIONS

Heated Print Surface Size	4" x 7/16" (100 x 10 mm)
Work Table Size	5-1/2" x 5-1/2" (140 x 140 mm)
Maximum Opening	1-1/2" (38 mm)
Input Voltage	USA 110V/60Hz
Machine Dimensions (L x W x H)	8-1/4" x 8-1/2" x 14-1/2" (201 x 216 x 368 mm)
Package Dimensions (L x W x H)	15" x 17" x 12-1/2" (381 x 432 x 316 mm)
Net Weight	27 lbs. (12.2 kg)

---