

SM 7555 / PARTS BOOK / ENGLISH

GLOBAL

Our experience. Your success

GLOBAL



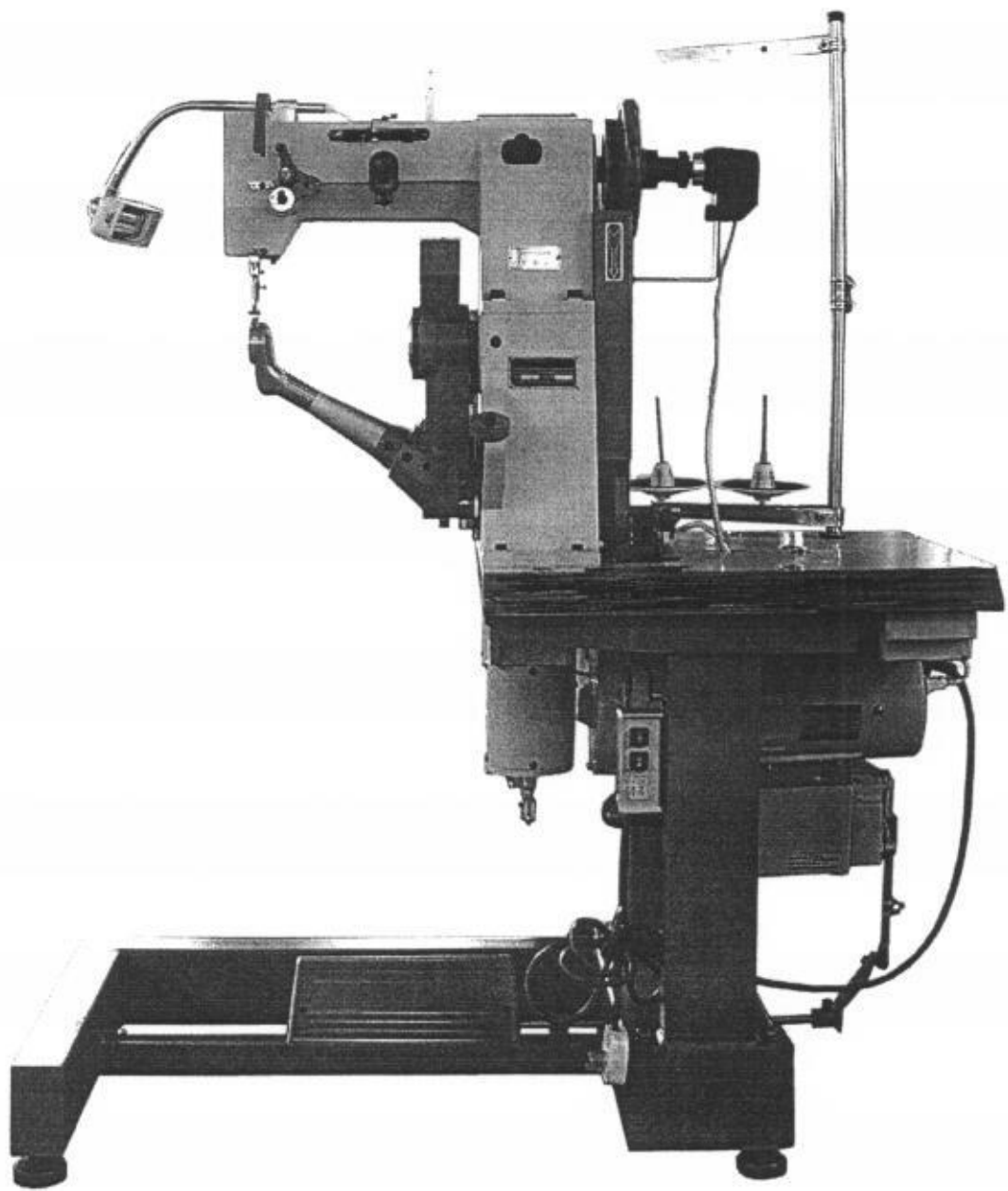

CONTENTS

I. Technical Parameter	1
II. Introduction and Preparation	1
III. Operation of the Sewing Machine	2
1. Fix the Sewing Needle	2
2. Threading	2
3. Essential to Sewing	3
4. Adjustment of Stitch Length	3
5. Tension adjustment of Sewing Thread	3
6. Threading and adjustment of Lower Thread	4
IV. Adjustment of the Sewing Machine	5
1. Adjustment of the Sewing Needle and the Inner/Outer Clamp	5
2. Speed Adjustment of the Shuttle	5
3. Adjustment of the Sewing Needle and the Shuttle	6
4. Lifting Capacity of the Clamp	6
5. Pressure Adjustment of the Clamp	7
6. Adjustment of the Stopping Position	7
7. Adjustment of the Winding Reel	7
8. Adjustment of the Chain and Replacement of the Ball Connecting Rod	8
V. Troubleshooting and Maintenance	9
1. Troubleshooting of Twisted Shuttle	9
2. Lubrication and Maintenance	9
VI . Remakes and notes	10
Attachment : Parts drawings	11-22
Appendix : Assembly drawing of bentholder (SF2-400)	

Thank you very much for your choice of this double thread side seam sewing machine. Please read the manual carefully before use !!

I. Technical Parameter

Use	: Side seams for sports shoes, leisure shoes and leather shoes.
Sewing Speed	: Stepless speed regulating
Stitch Length	: 3-13 mm
Stitch Type	: Double lock
Sewing Thickness	: 1,5 – 6 mm
Lifting Capacity	: Manual 8 mm; Treadle 13 mm
Travel of Needle Bar	: 35 mm
Sewing Needle	: CP X 5
Sewing Thread	: Compound thread
Motor	: 560 watt / 380 volts – Three-phase 560 watt / 220 volts – Single-phase
Lighting	: 7 watt / 220 volts – Single-phase
Weight	: 150 kgs
Overall Size	: 107 x 56 x 125 cm (L x W x H)

II. Introduction and Preparation

The on-off driver is applied to this sewing machine. When the machine is overcharged, the hand wheel will run idle, releasing the main shaft automatically. The motor stops running in two seconds to ensure each part of the machine.

First of all, switch on the machine to see if the rotation direction of the motor is conformable to the red arrow on the pulley cover. If the direction is opposite, switch in the other way round. Then operate the treadle in three different movements (Fig. 1) :

(1) Stepping on forward (position A) means advance. Stepping on lightly is slow while stepping on heavily is fast. Avoid stepping on heavily at the very beginning.

(2) Stop in neutral position

(3) Stepping on backwards (position B) means lifting the clamp so that it is easy to place the shoe onto the bent holder of the thread hook (Lifter rod is its popular name).

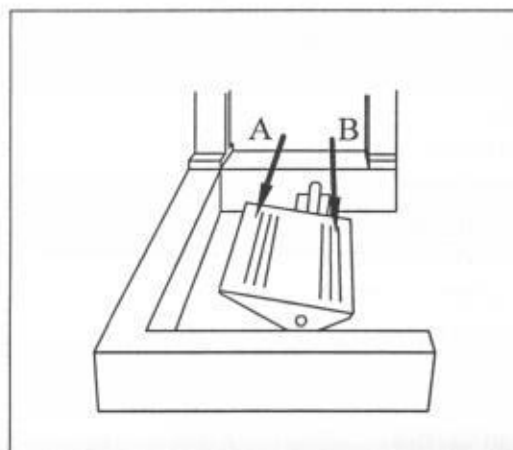

Fig. 1

III. Operation of the sewing machine

(1) Fix the sewing needle

(A) Turn the hand wheel according to the arrow indicated on the pulley cover until the needle bar reaches the highest position.

(B) Loosen the pinching screw to unclamp the needle socket.

(C) Insert the needle into the bottom of the needle socket with the long slot inward and the threading slot 100 towards the left.

(D) Fix the needle with the pinching screw.

(E) When the needle is in the lowest position, the tip is required to stick out 1 – 1,5 mm of the long slot of the shuttle. Such circumstances as winding or end breaking will occur if the tip sticks out too much (Fig. 2)

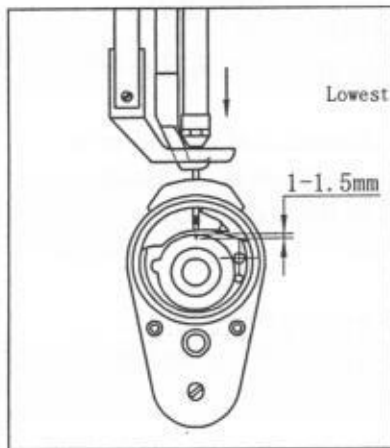

Fig. 2

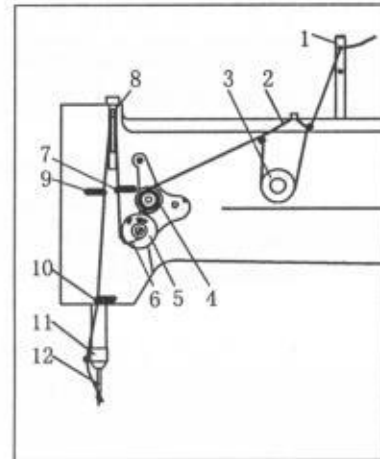

Fig. 3

2) Threading (Fig. 3)

The needle bar should be in the highest position when the threading is done. The thread end is drawn from the thread wheel. The threading has to be done according to the following order:

- (1) Threading bar
- (2) Threading gripper
- (3) Thread gripper plate
- (4) Assembly of thread carrier
- (5) Spring of narrowing rod
- (6) Assembly of thread carrier
- (7) Upper thread carrier
- (8) Narrowing rod
- (9) Thread carrier
- (10) Lower thread carrier
- (11) Head end of needle bar (Part # 23-39)
- (12) Sewing needle

3) Essential to sewing

The clamp of needle hole must align the thread slot of sole when the shoe is sewn. Go on stitching at the connection point. There should be three or four more stitches surpassing the starting point. Only when the shoe front is sewn can the bent holder be pushed forward or pulled backwards. The sewing thread can't be used until it has been soaked in silicon oil for 5 minutes and dried.

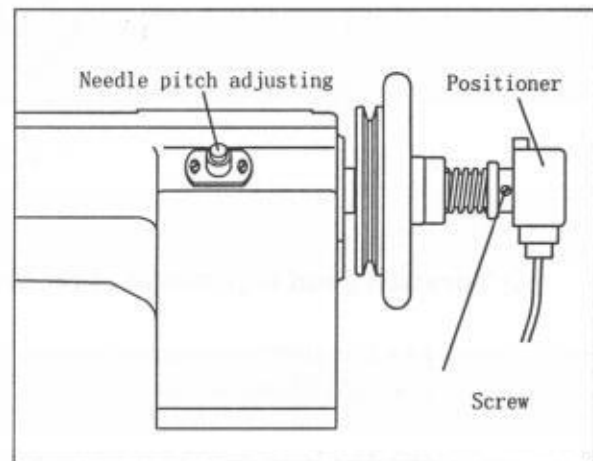

4) Adjustment of the stitch length (Fig. 4)

Fig. 4

To adjust the stitch length, press the button with one hand and turn the hand wheel with the other. When a click is heard, turn slightly the hand wheel to reduce or increase the stitch length according to the arrow on the frame.

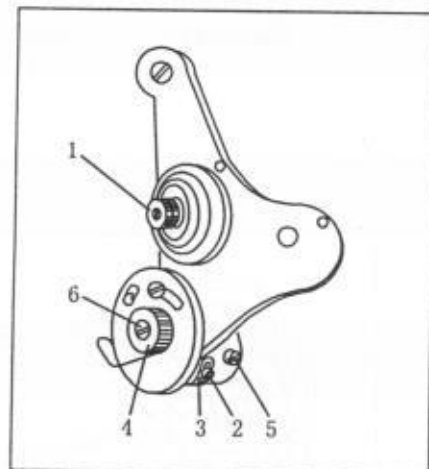

5) Tension adjustment of sewing thread (Fig. 5)

Fig. 5

(A) Turn the nut (1) clockwise to increase tension while turn it counterclockwise to reduce tension.

(B) Loosen the screw (2) and adjust the curved stopper (3) to make the spring of narrowing rod drop to the lowest position.

(C) Loosen the nut (4) and the screw (5). Turn the screw 6 towards to the left to increase the pressure of the spring of narrowing rod while turn it towards the right to reduce the pressure. After that, tighten the nut and the screw.

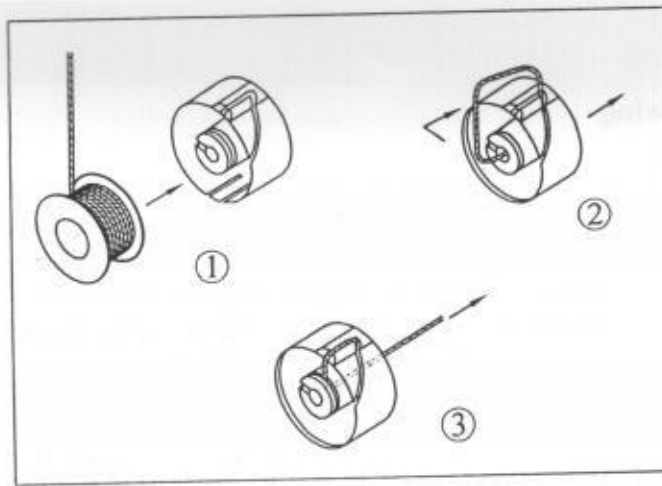

Fig. 6

6) Threading and adjustment of the lower thread

(A) The lower thread in the inner shuttle peg is threaded according to the order (1) – (3) illustrated in Fig.6.

(B) The lower thread is adjusted through the inner shuttle spring leaf. Prize up the spring leaf with screwdriver (Fig. 7) and the lower thread will be tightened.

(C) If the lower thread is too tight, flatten the hem of the spring leaf with screwdriver (Fig. 8).

(D) Make sure that the spring leaf is not so flat that it can't get in touch with the shuttle. As a result, the lower can't be adjusted.

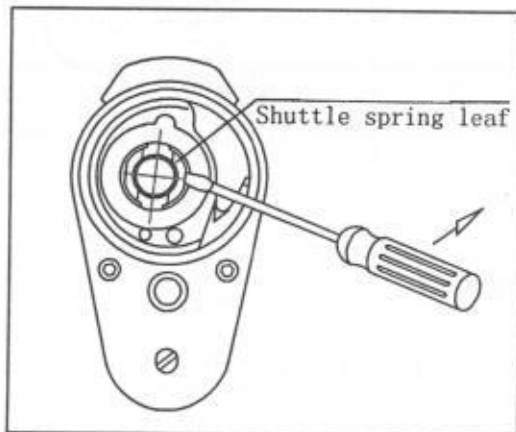

Fig. 7

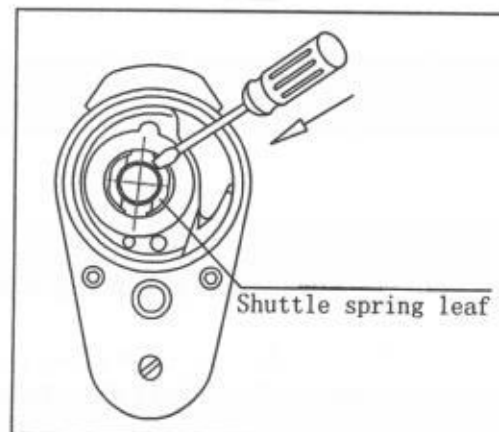

Fig. 8

IV. Adjustment of the sewing machine

(1) Adjustment of the sewing needle and the inner / outer clamp

(A) When the sewing needle descends from the highest point down to 16-18 mm, the needle rack together with the needle bar and the inner clamp begins to move backward (Fig. 9). The method of adjustment: Loosen the two set screws on the eccentric driving block (Fig. 12). Turn the hand wheel towards the red arrow to meet the requirements mentioned above. Then tighten the screws.

(B) The inner clamp and the sewing needle should remain synchronous. As the sewing needle descends, so does the inner clamp. However, the inner clamp can be made slower if the sewn material is thick. When adjusting: loosen the set screw (4) on the lifting eccentric wheel of clamp (5) (Fig. 10). Turn the hand wheel towards the red arrow. Tighten the screw when the inner clamp and the sewing needle become synchronous.

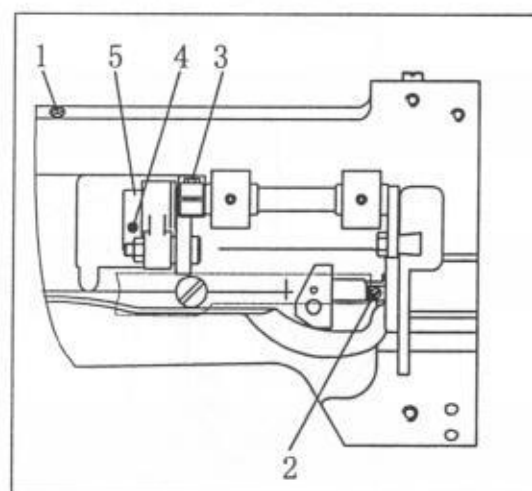
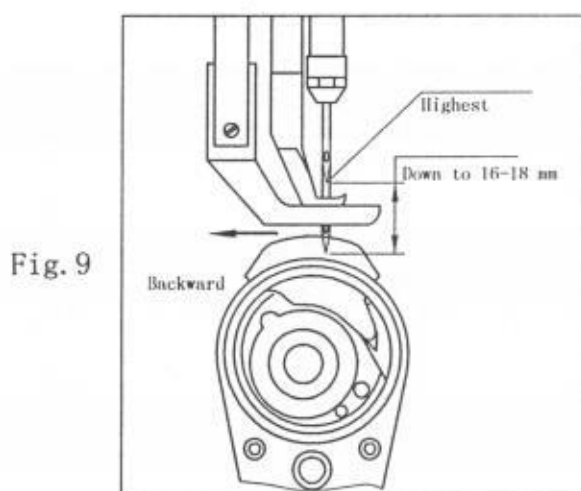

(2) Speed adjustment of the shuttle

(A) Dismount the belt cover and turn the hand wheel to make the needle bar at the highest position.

(B) Attention should be paid to the stand of convex pinion in the frame. The scales on both the convex pinion and the stand of convex pinion must be in alignment. (At the same time, the flat end of the synchronous belt wheel should be in the vertical position – see Fig. 11).

(C) If the two scales are not in alignment, the two adjusting screws in the driving sleeve on the end of the main shaft need adjusting. (see Fig. 12)

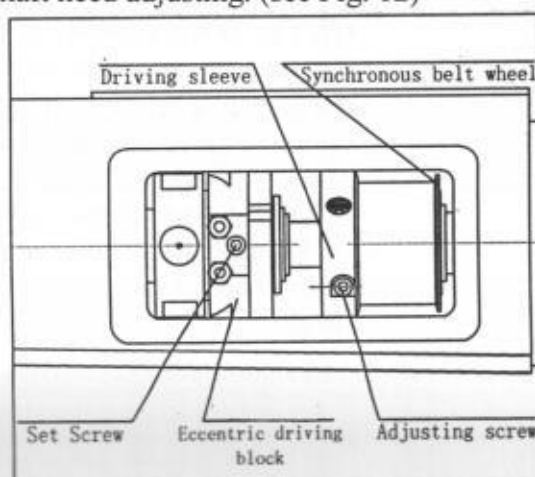
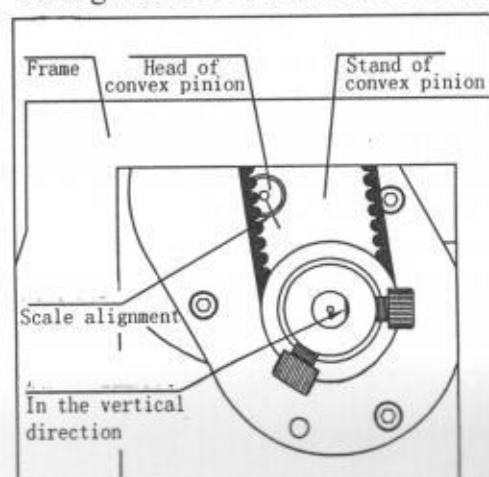

(3) Adjustment of the sewing needle and shuttle

(A) Loosen the two set screws of the synchronous belt wheel in the right hole of the frame (Fig.13).

(B) Turn the hand wheel to make the needle at the lowest position. And then lift the needle by 2 – 2,5 mm. Here the shuttle point is just at 1/3 of the upper recess of sewing needle. The distance between the shuttle point and the needle slot surface is 0,05 mm (Fig. 14).

(C) The wider the needle pitch is, the lower the shuttle point will be at the needle slot. Make sure that the shuttle point can't be too high or too low. Otherwise it might run into the top or bottom of the needle recess.

(D) Tighten the screws after adjustment.

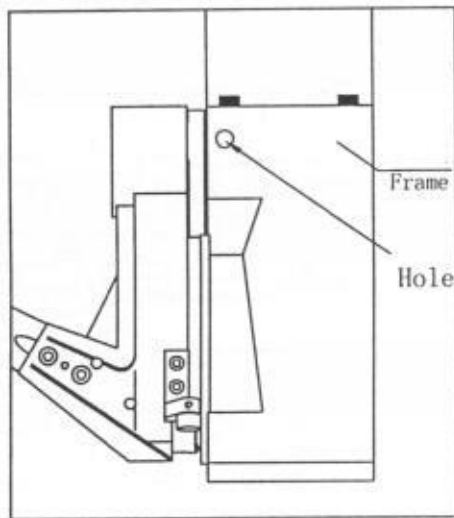

Fig. 13

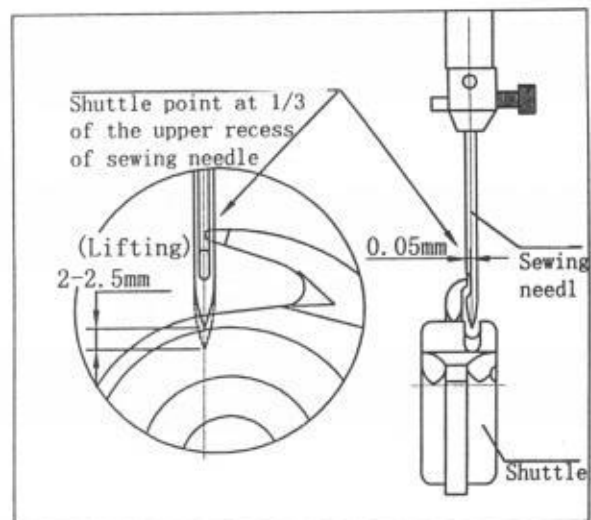

Fig. 14

(4) Lifting capacity of the clamp

The lifting capacity of the inner clamp depends on the thickness of the sewn materials. The inner clamp must be of the sewn material when the outer clamp holds it down.

(A) Loosen the wing nut to adjust the lifting capacity of the clamp. Move it upwards to increase the lifting capacity while downwards to reduce the lifting capacity (Fig. 15). After adjustment tighten the nut.

(B) The lifting capacity of the outer clamp can also be adjusted. The height of the outer clamp needs adjusting owing to different kinds of material. Loosen the adjusting screw (1) (Fig. 10) and the guide screw (2) (Fig. 10). Move the outer clamp up and down to a proper height.

(C) Movement changes if the inner and outer clamps are not equal in position. In this case, the inner clamp needs adjusting. Put down the clamp and grasp the inner clamp. Loosen screw (3) (Fig. 10) and move it up and down to a proper height.

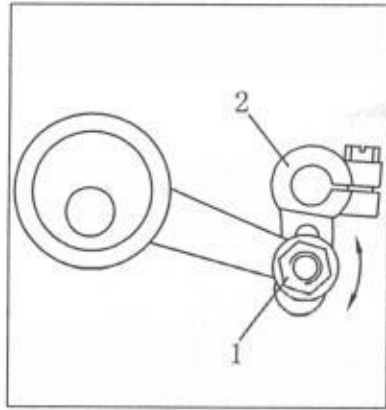

Fig. 15

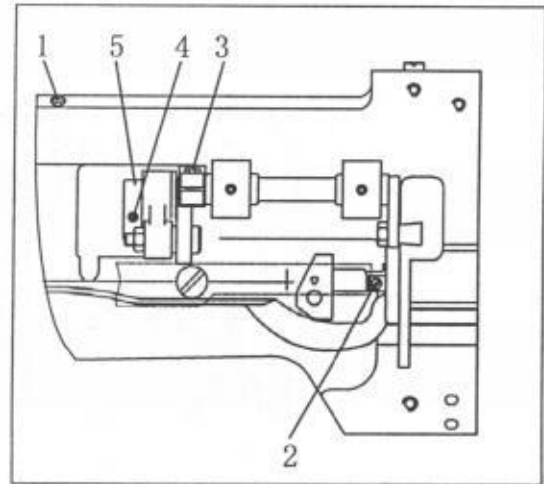

Fig. 10

(5) Pressure adjustment of the clamp

The clamp pressure is adjusted with the adjusting screw (1) (Fig. 10). Rotate the screw clockwise to increase pressure while counterclockwise to reduce pressure.

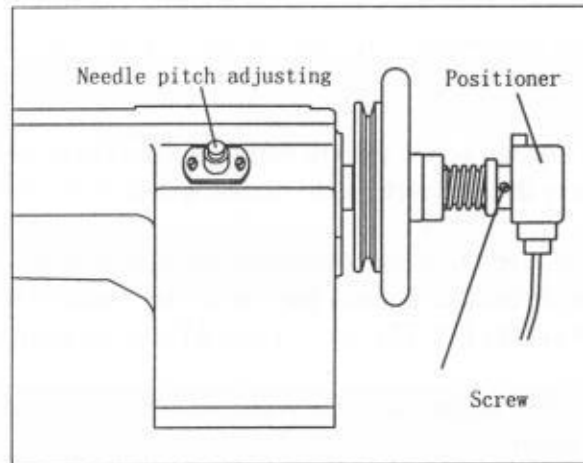

Fig. 4

(6) Adjustment of stopping position

The stopping positioner is used to control the pause position of the needle bar. Loosen the screw (Fig.4) on the positioner and adjust the relative position between the positioner and the main shaft. After adjustment tighten the screw.

(7) Adjustment of the winding reel

Generally, the upper thread should keep loose when the sewing needle pierces the sewn material. When the thread is hooked by the shuttle hook and the narrowing rod begins to move upwards, the upper thread should be wound. Otherwise, the relative position between the winding cam Part # 22-15 and the main shaft needs adjusting. Loosen the two screws on Part # 22-15. Turn the hand wheel with one hand and the adjustment can be done.

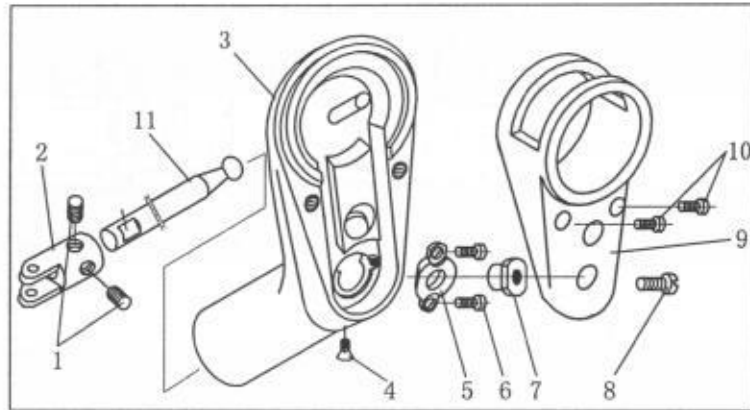

Fig. 16

**(8) Adjustment of the chain and replacement of the ball connecting rod
(Fig. 16)**

When the chain in the bent holder (3) becomes loose, it can be adjusted in the following ways:

(A) Loosen screw (10) to dismantle the cover of bent holder (9). Then loosen slowly the two screws (6) on the sprocket washer(5) in the bent holder (3).

(B) Adjust the screw (4) below the bent holder (3). Turn it right to make the tight. After that tighten the screw (6). Loosen the screw (8) on the cover of the bent holder (9). The nut (7) should also be adjusted.

(C) After adjustment, the parts should be remounted successively and tighten the screw.

(D) Dismantle the cover of bent holder, the sprocket and so on.

The ball connecting rod (11) can be removed when the screw (1) is loosened. The flat end of the ball connecting rod should be in the same direction as it was dismantled. So it is with the other ball connecting rod.

V. Troubleshooting, lubrication and maintenance

(1) Troubleshooting of twisted shuttle

Switch off the machine. Turn the hand wheel counterclockwise to make the thread hook reverse so as to remove the twisted thread. If not, raise the clamp, loosen the screw of the cover of bent holde (Part # 40-42) and remove some relevant components. The twisted thread can be taken out. When the components are put back, needle plate should remain in the middle.

(2) Lubrication and maintenance

Always keep the machine clean. According to its use, clean the clamp, the shuttle and the shuttle peg regularly. Oil each of the holes with red marks once every shift. So it is with the shuttle. In normal cases, oil the sleeve of the needle bar and the connecting rods every day. Check and oil the machine carefully when it is reused after a long time. Test run and slow running are required.

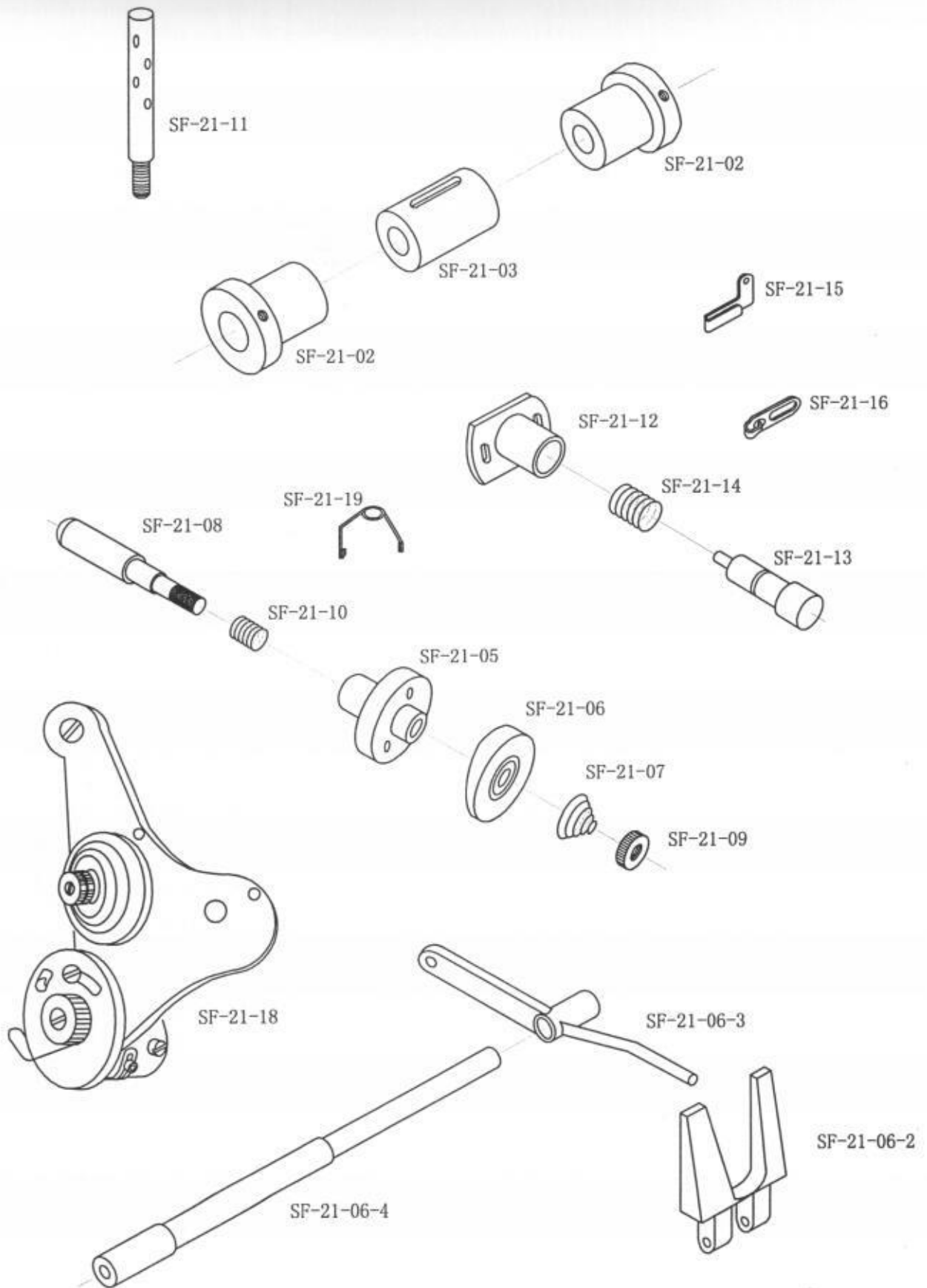

Fig. No.	Item	Quantity
SF-21-01	Frame	1
SF-21-02	Fore/Back sleeve of the main shaft	2
SF-21-03	Mid sleeve of the main shaft	1
SF-21-05	Fixed sleeve	1
SF-21-06	Clamping sleeve	1
SF-21-06-2	Loose ends block	1
SF-21-06-3	Connecting rod of loose ends	1
SF-21-06-4	Axle	1
SF-21-07	Cone spring	1
SF-21-08	Crown bar	1
SF-21-09	Nut	2
SF-21-10	Spring	1
SF-21-11	Narrowing rod	1
SF-21-12	Spring seat	1
SF-21-13	Pin	1
SF-21-14	Spring	1
SF-21-15	Small thread carrier	1
SF-21-16	Thread carrier	1
SF-21-17	Loose ends nail	1
SF-21-18	Thread gripper	1 set
SF-21-19	Guide ring	1

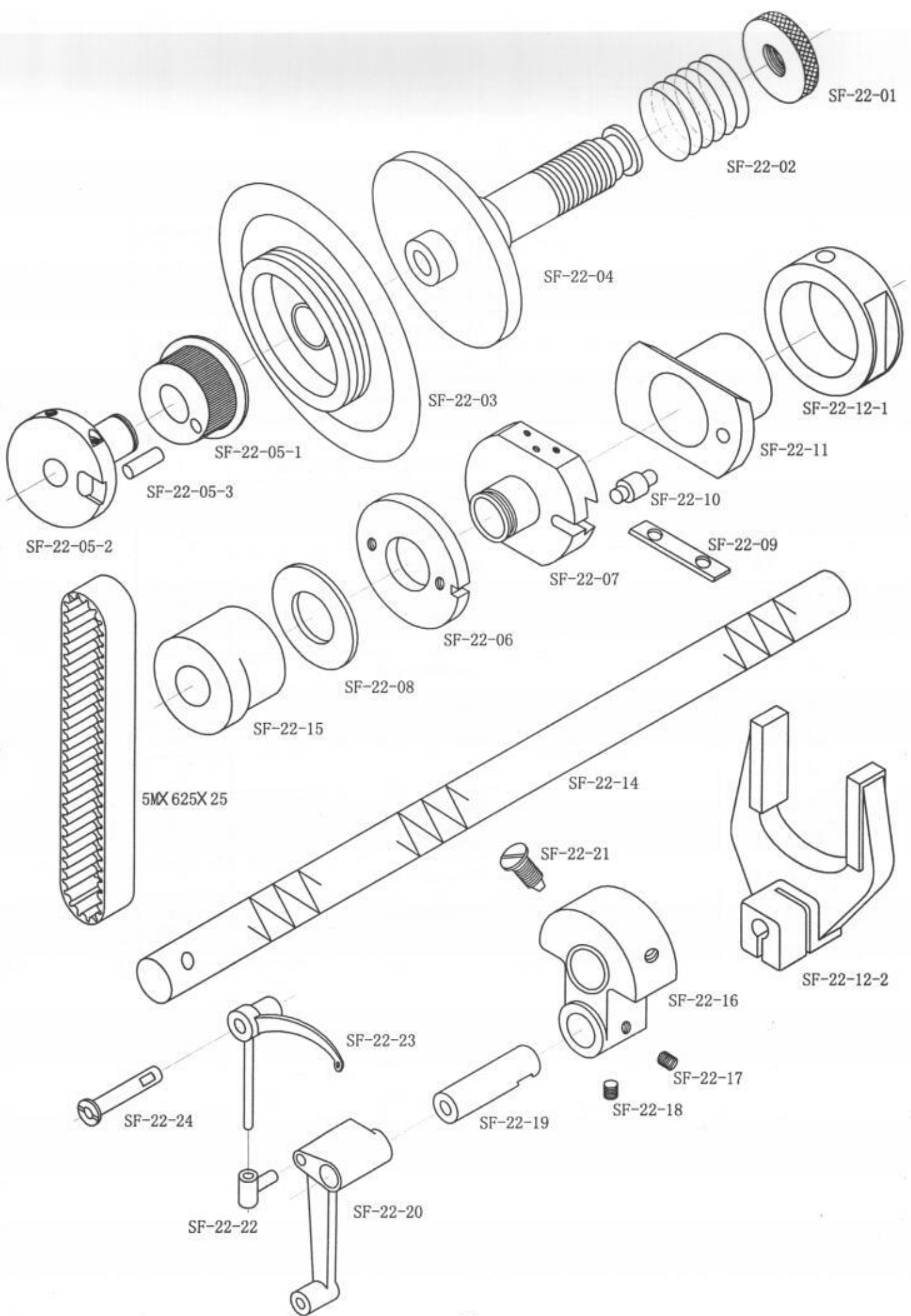

Fig. No.	Item	Quantity
SF-22-01	Round nut	1
SF-22-02	Spring	1
SF-22-03	Belt wheel	1
SF-22-04	Release collar	1
SF-22-05-1	Synchronous belt wheel	1
SF-22-05-2	Driving sleeve	1
SF-22-05-3	Pin	1
SF-22-06	Eccentric adjusting block	1
SF-22-07	Eccentric driving block	1
SF-22-08	Spacer	1
SF-22-09	Gag	1
SF-22-10	Location pin	1
SF-22-11	Swing eccentric of needle bar	1
SF-22-12-1	Copper sleeve	1
SF-22-12-2	Fork	1
SF-22-14	Main shaft	1
SF-22-15	Winding cam	1
SF-22-16	Crank of needle bar	1
SF-22-17	Location screw of articulation	1
SF-22-18	Screw of articulation	1
SF-22-19	Articulation of connecting rod of needle bar	1
SF-22-20	Connecting rod of needle bar	1
SF-22-21	Location screw of needle bar	1
SF-22-22	Slide bar	1
SF-22-23	Narrowing rod	1
SF-22-24	Articulation of narrowing rod	1
5M×625×25	Synchronous belt	1

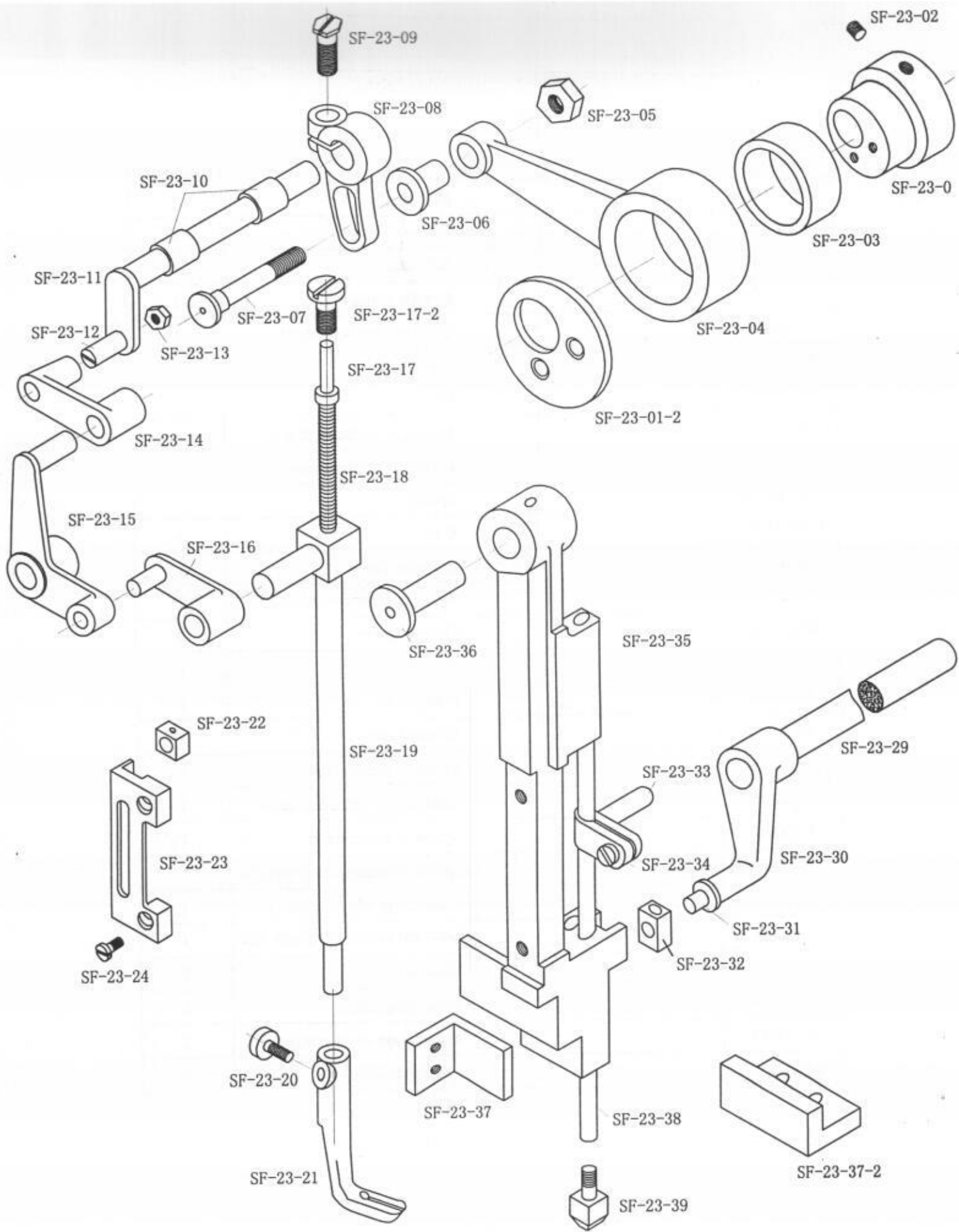

Fig No.	Item	Quantity
SF-23-01	Lifting eccentric of clamp	1
SF-23-01-2	Cover plate of lifting eccentric of clamp	
SF-23-02	Screw of lifting eccentric of clamp	2
SF-23-03	Needle bearing of eccentric connecting	
SF-23-04	Eccentric connecting rod	1
SF-23-05	Nut of articulation of connecting rod	2
SF-23-06	Articulation sleeve of connecting rod	1
SF-23-07	Articulation of connecting rod	1
SF-23-08	Adjusting crank	1
SF-23-09	Screw of adjusting crank	1
SF-23-10	Swing sleeve of clamp	2
SF-23-11	Lifting jackshaft of clamp	1
SF-23-12	Screw of jackshaft	1
SF-23-13	Nut of jackshaft	1
SF-23-14	Connecting rod of crank	1
SF-23-15	Lifting lever of clamp	1
SF-23-16	Connecting rod of lever	1
SF-23-17	Assembly of crown bar	1
SF-23-17-2	Screw of clamping bar	1
SF-23-18	Spreader spring of inner clamp	1
SF-23-19	Inner clamping bar	1
SF-23-20	Screw of inner clamp	1
SF-23-21A	Inner clamp	1
SF-23-21B	Inner clamp	1
SF-23-21C	Inner clamp	1
SF-23-22	Slide block	1
SF-23-23	Slideway	1
SF-23-24	Slideway screw	1
SF-23-29	Jackshaft of swing span	1
SF-23-30	Left crank of swing span	1
SF-23-31	Sliding axle of swing span	1
SF-23-32	Slide block of swing span	1
SF-23-33	Joint of needle bar	1
SF-23-34	Screw of connecting axle of needle bar	1
SF-23-35	Swing span of needle bar	1
SF-23-36	Pin of swing span of needle bar	1
SF-23-37	Stopper of needle rack	1
SF-23-37-2	Back stopper of needle rack	1
SF-23-38	Needle bar	1
SF-23-39A	Head end of needle bar	1
SF-23-39B	Head end of needle bar	1

The parts with "✓" in the table are referred to those fixed in this machine. Notice the different types of the parts.

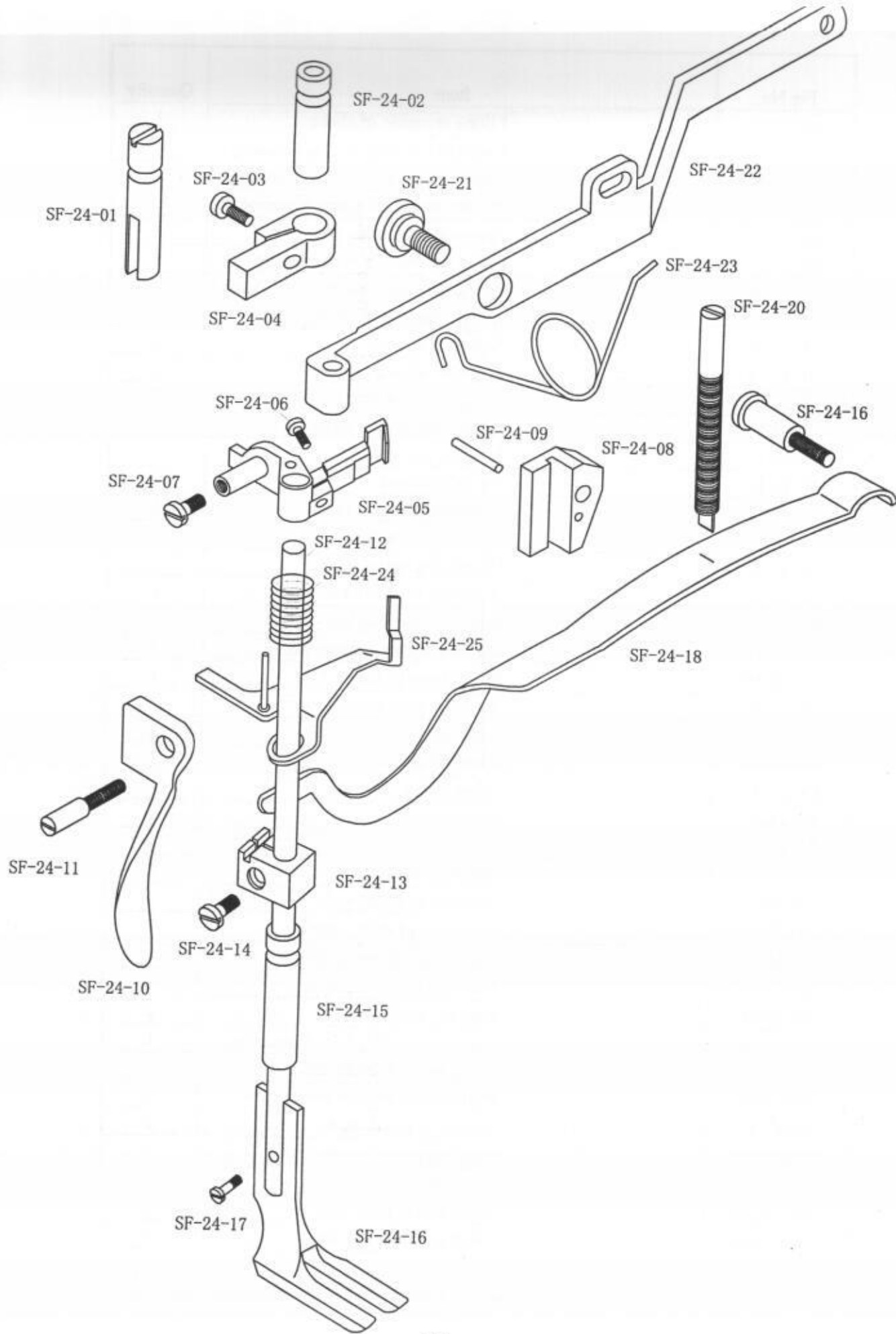

Fig. No.	Item	Quantity
SF-24-01	Guide pillar of clamping bar	1
SF-24-02	Upper sleeve of outer clamping bar	1
SF-24-03	Guide screw of clamping bar	1
SF-24-04	Guide of clamping bar	1
SF-24-05	Lifting rack of clamping bar	1
SF-24-06	Set screw of lifting rack	1
SF-24-07	Adjusting screw	1
SF-24-08	Guide holding-down plate	1
SF-24-09	Spring pivot of guide holding-down plate	1
SF-24-10	Trigger piece of clamp	1
SF-24-11	Screw of trigger piece of clamp	1
SF-24-12	Clamping bar	1
SF-24-13	Spring rack of clamping bar	1
SF-24-14	Screw of spring rack of clamping bar	1
SF-24-15	Lower sleeve of outer clamping bar	1
SF-24-16A	Outer clamp (single side)	1
SF-24-16B	Outer clamp	1
SF-24-17	Set screw of outer clamp	1
SF-24-18	Spring of clamping bar	1
SF-24-19	Stopper pin of clamping spring	1
SF-24-20	Adjusting screw of clamping spring	1
SF-24-21	Clamp screw	1
SF-24-22	Clamp rocker arm	1
SF-24-23	Torsion spring of clamp rocker arm	1
SF-24-24	Cam spring of loose ends	1
SF-24-25	Driving plate of loose ends	1

The parts with "✓" in the table are referred to those fixed in this machine. Notice the different types of the parts.

Fig. No.	Item	Quantity
<u>SF2-401</u>	Frame	1
SF-40-02	Synchronous belt wheel	1
<u>SF2-403</u>	Elliptic gear shaft	2
<u>DF-404</u>	Spacer	1
<u>DF-405</u>	Elliptic gear	2
<u>DF-406</u>	Washer	1
<u>SF2-407</u>	Cover of elliptic gear casing	1
<u>SF2-408</u>	Elliptic gear casing	1
<u>SF2-409</u>	Elliptic gear shaft	1
<u>SF2-410</u>	Synchronous belt wheel	1
SF-40-11	Washer	1
SF-40-12	Locking block	1
<u>SF2-413</u>	Washer	1
<u>DF-914</u>	Synchronous belt wheel	1
SF-40-15	Baffle of synchronous belt wheel	1
<u>SF2-416</u>	Hub of bent holder	1
SF-40-17	Cover of bent holder	1
<u>DF-918</u>	End cover axle	1
SF-40-19	Spacer	1
<u>SF2-420</u>	Bent holder	1
<u>SF2-421</u>	Ball connecting rod	1
SF-40-22	Sleeve of universal joint	1
SF-40-23	Connecting block	1
SF-40-24	Universal joint	1
<u>SF2-425</u>	Fixed pin of gear	1
<u>SF2-426</u>	Gear support	1
<u>SF2-427</u>	Composite gear	1
SF-40-28	Toothed universal joint	1
SF-40-29	Pin	1
<u>SF2-430</u>	Fixed cover	1

<u>SF2-431</u>	Ball connecting rod	1
SF-40-32	Universal joint	1
<u>DF-933</u>	Universal joint	1
DF-934	Synchronous belt wheel	1
DF-935	Support of synchronous belt wheel	1
SF-40-36	Bearing baffle	1
SF-40-37-B	Support	1
SF-40-38-B	Support Bearing	2
<u>SF2-439</u>	Connecting sleeve	1
SF-40-40	Head end of bent holder	1
SF-40-41A	Shuttle driver (11.2)	1
SF-40-41B	Shuttle driver (11.6)	1
SF-40-41C	Shuttle driver (11.8)	1
SF-40-42	Cover of bent holder	1
SF-40-43	Geared ring	1
SF-40-44	Shuttle stand	1
SF-40-45A	Needle plate (Slot 1.8)	1
SF-40-45B	Needle plate (Slot 2.4)	1
SF-40-45C	Needle plate (Slot 2.8)	1
SF-40-46	Shuttle	1
SF-40-46-2	Shuttle spring leaf	1
SF-40-47	Bobbin	1
SF-40-48	Bobbin cover	1 set
SF-40-48-2	Bobbin cover spring leaf	1
SF-40-53	Gear	1
SF-40L-54	Nut ((External)	1
SF-40L-55	Sprocket (Internal)	1
SF-40L-56	Sprocket washer (Internal)	1
SF-40-57	Bent holder weighting	1
T5×440×18	Synchronous belt	1
5M×375×12	Synchronous belt	1

The parts with "✓" in the table are referred to those fixed in this machine. Notice the different types of the parts.

