



GLOBAL

WF 955

Instruction & parts Manual

www.globalsew.com

info@globalsew.com

CONTENTS

1. PRECAUTIONS BEFORE STARTING OPERATION.....	2
2. MAIN SPECIFICATIONS.....	2
3. PREPARATION AND LUBRICATION.....	3
4. REPLACE NEEDLES.....	3
5. WINDING.....	4
6. WINDING ADJUSTMENT.....	4
7. REMOVING AND INSERTING THE BOBBIN.....	4
8. THREADING.....	5
9. REGULATING THE THREAD TENSIONS.....	5
10. ADJUSTMENT OF THE PRESSURE ON THE MATERIAL.....	6
11. ADJUSTING THE LIFT OF THE ALTERNATING PRESSER FEET.....	6
12. STITCH LENGTH ADJUSTMENTS AND REVERSING LEVER.....	6
13. ADJUSTING THE HEIGHT OF THE FEED DOG.....	6
14. RELATIVE POSITION OF THE FEED DOG TO NEEDLE PLATE.....	7
15. THE POSITION OF THE NEEDLE AND THE NEEDLE HOLE OF THE FEED DOG.....	7
16. TIMING THE NEEDLE WITH FEED DOG.....	7
17. ADJUSTING THE HEIGHT OF THE NEEDLE BAR.....	8
18. TIMING BETWEEN THE HOOK AND THE NEEDLE.....	8
19. ADJUSTING THE HEIGHT OF THE PRESSER FEET.....	8
20. TIMING OF THE VIBRATING PRESSER FOOT.....	9
21. ADJUSTMENT OF THE CLEARANCE BETWEEN FEED FORKED CONNECTION AND FEED FORK COLLAR	9
22. ADJUSTING THE THREAD CONTROLLER SPRING.....	9

1. PRECAUTIONS BEFORE STARTING OPERATION

1) Safety Precautions:

- (1) When turning the power on, keep your hands and fingers away from the area around/under the needle and the area around the balance wheel.
- (2) Power must be turned off when the machine is not in use, or when the operator leaves the seat.
- (3) Power must be turned off when tilting the machine head, installing or removing the "V" belt, adjusting the machine, or when replacing.
- (4) Avoid placing fingers, hairs, bars etc., near the balance wheel, "V" belt, bobbin winder balance wheel, or motor when the machine is in operation.
- (5) Do not insert fingers into the thread take-up cover, under/around the needle, or balance wheel when the machine is in operation.
- (6) If a belt cover, finger guard, eye guard are installed, do not operate the machine without these safety devices.

2) Precautions before Starting Operation:

- (1) If the machine's oil pan has an oil sump, never operate the machine before filling it.
- (2) If the machine is lubricated by a drop oiler, never operate the machine before lubricating.
- (3) When a new sewing machine is first turned on, verify the rotational direction of the balance wheel with the power on. (The balance wheel should rotate counter-clockwise when viewed from the balance wheel)
- (4) Verify the voltage and (single or three) phase with those given on the machine nameplate.

3) Precautions for Operating Conditions:

- (1) Avoid using the machine at abnormally high temperature (35°C or higher) or low temperature (5°C or lower)
- (2) Avoid using the machine in dusty conditions.

2. MAIN SPECIFICATIONS

Item		WF 955
Max. Sewing Speed		2000 rpm
Stitch Length		0-10 mm
Take-up Lever Stroke		71.5 mm
Needle Bar Stroke		35 mm
Height of Between Main and Sub Presser Foot		2-5 mm
Presser foot lift	By Hand	8 mm
	By Knee	14mm
Needle		DP×17 22# 24#
Rotating Hook		Double Capacity Hook
Lubrication		Manual
Motor		370W Clutch Motor

3. PREPARATION AND LUBRICATION

1) Cleaning the machine

Before leaving the factory, the machine parts are coated with rust-preventive grease, which may be hardened and contaminated by dust during storage and shipment. This grease must be removed with gasoline.

2) Examination

Though every machine is confirmed by strict inspection and test before leaving the factory, the machine parts may be loose or deformed after long distance transportation with jolt. A thorough examination must be performed after cleaning the machine. Turn the balance wheel to see if there is running obstruction, parts collision, uneven resistance or abnormal noise. If these exist, adjustment must be made accordingly before run-in operation.

3) Oiling (Fig.1, 2, 3, 4)

Please do not operate the machine before lubricating well. The points with arrow in the fig are oil positions.

Caution: Please use white spindle oil.

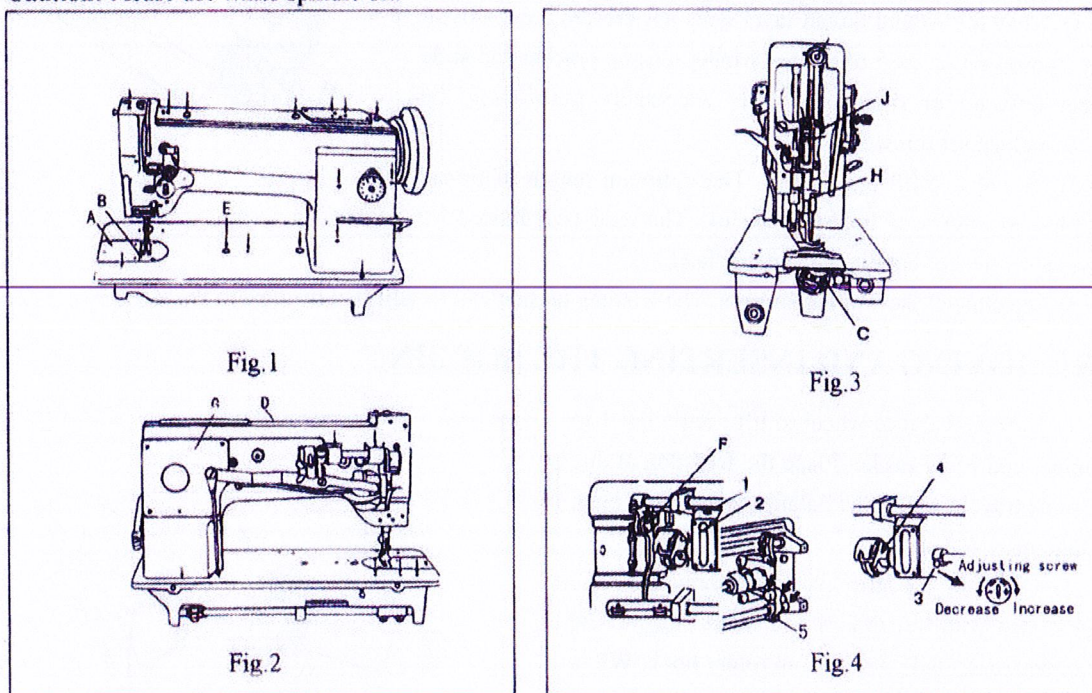

Lubrication of rotating hook (Fig.4)

Add the oil from the oil hole 1 until to the position 2.

Adjusting the lubrication (Fig.4)

Oil adjusting screw 3 can adjust the lubrication of the rotating hook: Turn oil-adjusting screw 3 clockwise to increase oil and turn oil-adjusting screw 3 counter-clockwise to decrease oil.

4. REPLACE NEEDLES (Fig.5)

1) Turn the balance wheel to lift needle bar 1 to the upper end of its stroke.

2) Loosen needle clamp screw 2. While keeping the long groove of the needle leftward fully insert the needle shank up to the bottom of the needle socket.

Caution: The direction of the long groove should be left.

3) Then tighten needle clamp screw 2.

5. WINDING (Fig.6)

1) Put the bobbin 3 on the bobbin winder shaft as far as it will go.

2) Bring the thread forward toward the bobbin and wind from below in clockwise direction several times around the bobbin.

4) Push the lever 4 toward other side so that the winding wheel and "V" belt will engage and then start the machine.

5) The winding wheel will automatically be free from "V" belt and stop after the bobbin is filled with thread.

6. WINDING ADJUSTMENT (Fig.6)

1) When the wound thread layer does not present a cylindrical shape, loosen set screw 5 of bobbin winder tension bracket and slide bracket leftward or rightward. After adequately positioning the bracket, tighten set screw 5.

2) Do not overfill the bobbin. The optimum length of thread will fill about 80% of bobbin capacity. This can be adjusted by adjusting screw 6 of bobbin winder stop latch.

3) Adjusting of the winding tension: The winding tension can be adjusted by tension screw 7.

7. REMOVING AND INSERTING THE BOBBIN

1) Turn the balance wheel to lift needle bar 1 to the upper end of its stroke. Place the feed dog at this side in its travel turning the balance wheel, and open the slide plate A. (Fig.1)

2) Open on the drip pan, and then open the hinged latch with left thumb and index finger. And pull bobbin case and bobbin from rotary hook. While the latch is held open, the bobbin will be retained in the bobbin case. Release of the latch and turning of the open side of the bobbin case downward will cause the bobbin to drop out.

3) Hold the bobbin between the thumb and forefinger of your right hand and pull out a length of about 5 cm of thread. Holding the bobbin case in your left hand turn the open side up and place the threaded bobbin into it. (Fig.7)

4) With the right hand guide the thread into the slot in the edge of the bobbin case. Then pull the thread to the left, under tension spring 1 (Fig.7) and into the delivery eye. In order to keep the bobbin from dropping out of the case when it is turned with the open side down, always keep the hinged latch at the front of the bobbin

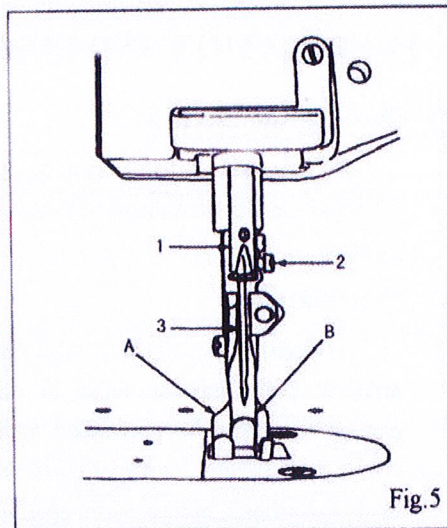

Fig.5

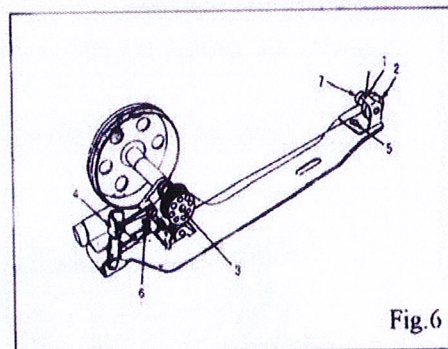

Fig.6

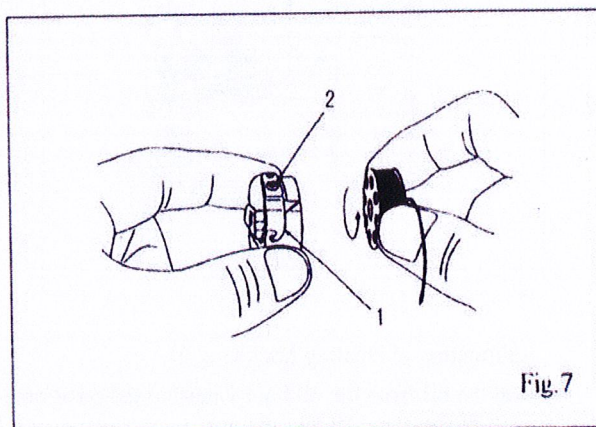

Fig.7

case open.

5) Take the threaded bobbin case by the latch and place it on the center stud of the bobbin case holder. Release latch and press bobbin case on to center stud until the latch catches the undercut thereon with a click that can be heard. Permit about 5 cm of bobbin thread to hand down freely. Be sure to push the slide plate to the right before starting to sew.

8. THREADING (Fig.8)

1) Raise the needle bar to its highest point and lead the thread from the thread stand the following order. From the thread stand lead the thread from back to front through the lower guide hole in pin 1 on top of the machine arm, then again from right to left through the upper guide hole in this pin. Pass thread in weaving fashion through the three holes in guide 2, and from right to left over and between the tension disc 3. Now pull thread downward and from right to left beneath and around thread controller 4, continue to pull thread upward against the pressure of the wire spring into the fork 5, in the thread controller. Guide upward through the point of controller discs 6, and thread guide 7, and from right to left through the eye in take-up lever 8, down through thread guide 7, again and then through 9, 10, 11 and from left to right through the eye of the needle 12.

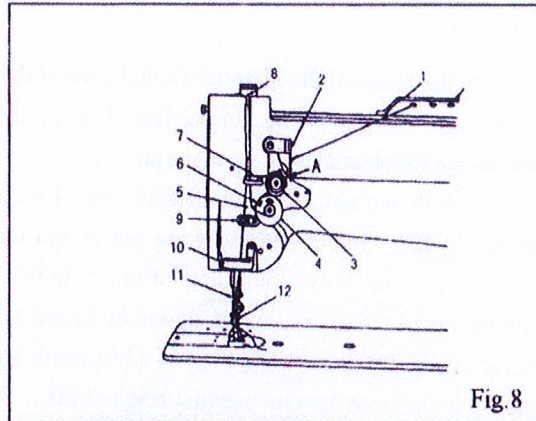

Fig.8

2) After the above threading, hold the end of thread with your left hand, and turn the balance wheel with your right hand so that bobbin thread may be picked up by needle thread. And put their ends of thread back through under the presser foot for starting operation.

9. REGULATING THE THREAD TENSIONS

For ordinary stitching, the tension of the upper and the lower threads should be equal so as to lock both threads in the center of the material. (1 Fig.9) If the tension on either thread is stronger than on the other, imperfect stitching will be the result. If the tension on the upper thread is greater than that on the lower thread, it will lie straight along the upper surface of the material. (2 Fig.9) If the tension on the lower thread is greater than that on the upper thread, the lower thread will lie straight along the underside of the material. (3 Fig.9)

1) Tension of the upper (needle) thread:

Before adjusting the tension of the upper (needle) thread, be certain that the presser foot is let down but not in lifted position. To adjust tension, turn serrated nut (A Fig.8) on tension device to clockwise to increase tension, while turning it to counter-clockwise to decrease it.

2) Tension of the lower (bobbin) thread: (Fig.7)

The lower (bobbin) thread tension is controlled by the larger screw (2 Fig.7) near the end of the spring at the outside of the bobbin case. Turning this screw to clockwise to increase the thread tension, while turning it to counter-clockwise to decrease it.

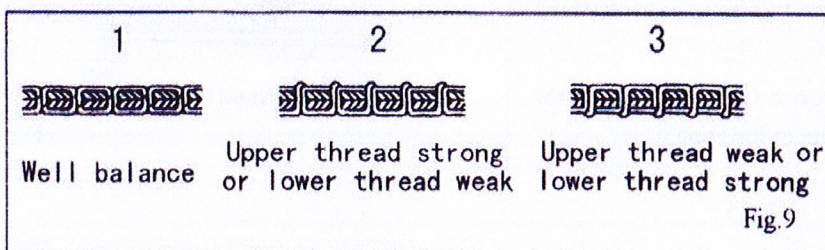

10. ADJUSTMENT OF THE PRESSURE ON THE MATERIAL

The pressure of the presser feet is adjusted by the screw D (Fig.2) with screwdriver. To increase the pressure, turn the screw to clockwise and to counter-clockwise to decrease it.

11. ADJUSTING THE LIFT OF THE ALTERNATING PRESSER FEET

(Fig.10)

The thickness of the material should control the height of the lift of the alternating presser feet. The lift should be just enough for clearance of the material.

1) With normal adjustment both feed lift to equal height: To later lift, loosen the wing nut A and move the link and stud assembly along the slot-move up to raise the feeding presser foot and push down to lower this foot. Tighten wing nut upon completion of adjustment. However, some materials may require unequal height of lift.

2) When altering the lift of the lifting presser foot (A Fig.5) unequally against that of the vibrating presser foot (B Fig.5) or vice versa, see the instructions "ADJUSTING THE HEIGHT OF THE PRESSER FEET"

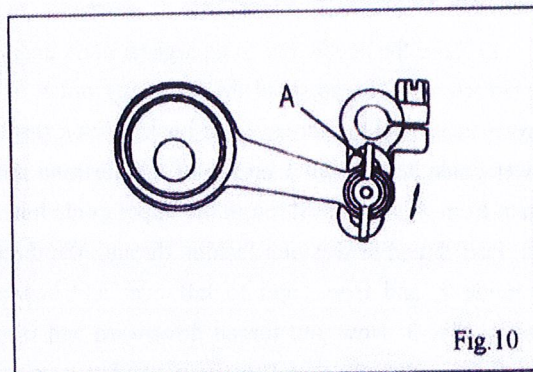

12. STITCH LENGTH ADJUSTMENTS

AND REVERSING LEVER (Fig.11)

Stitch length can be set by turning the detail 2. Numeric figures on the dial show the stitch length in mm. The desired numeric figure on the dial should be set at just above, while depressing the reversing lever 1 slightly.

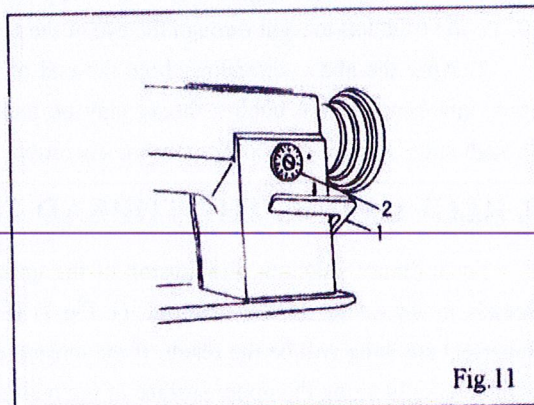

13. ADJUSTING THE HEIGHT OF THE FEED DOG (Fig.12)

The maximum height of the feed dog (1 Fig.12) from the surface of the needle plate (2 Fig.12) is normally 1 mm.

1) Lay down the machine head toward the other side, and turn the balance wheel so as to raise the feed dog to its highest point.

2) Loosen bell crank screw F (Fig.4) and adjust the height of the feed dog by raising or lowering it.

3) Securely tighten the screw upon completion of adjustment.

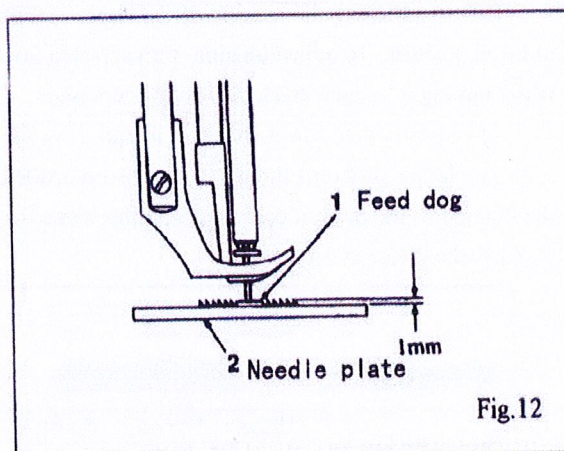

14. RELATIVE POSITION OF THE FEED DOG TO NEEDLE PLATE

(Fig.13)

- 1) Set the stitch length at minimum.
- 2) Turn the balance wheel so as to raise the feed dog to its highest point.
- 3) Lay down the machine head toward the other side and loosen the screw 5 (Fig.4).
- 4) Adjust to be 32.1 mm from the edge of the needle plate to the center of the needle hole on the feed dog. (Fig.13)
- 5) Securely tighten the screw.

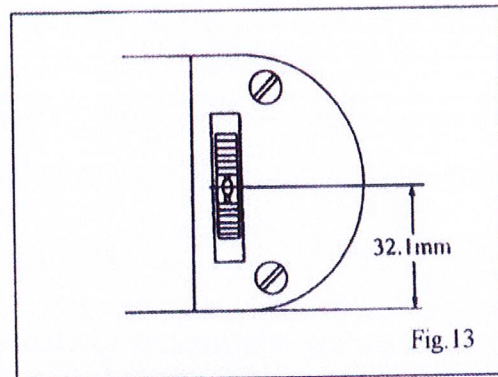

15. THE POSITION OF THE NEEDLE AND THE NEEDLE HOLE OF THE FEED DOG

Turning the balance wheel to lower slowly the needle bar, check whether the needle descends to the center of the needle hole of the feeder or not. (Please check again the needle is perfect one.)

- 1) Remove the cover G (Fig.2) and loosen the screw 1 (Fig.14) slightly.
- 2) Holding the bottom of the needle bar rock frame H (Fig.3), move it as may be required to get the correct position to the feed dog.
- 3) Tighten the screw and close the cover.

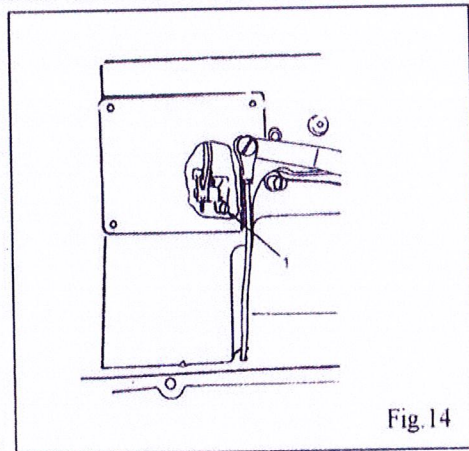

16. TIMING THE NEEDLE WITH FEED DOG (Fig.15, Fig.16)

It is important that the timing relationship between the needle on its downward stroke and the feed dog movement is maintained at all times. When the scarf of the needle on the downward stroke reaches the top surface of the feed dog, the feed dog movement must start. When adjustment is required, use the following procedure to change the position of cam

- 1) Loosen the screw 1 for cover plate 2 and then remove the cover plate 2.
- 2) Normally put the arrow mark 7 of the cam 6 on the V ditch 5 of arm shaft. Then tighten the cam screw.
- 3) Turn the balance wheel to the needle at 1 mm up from its lowest point.

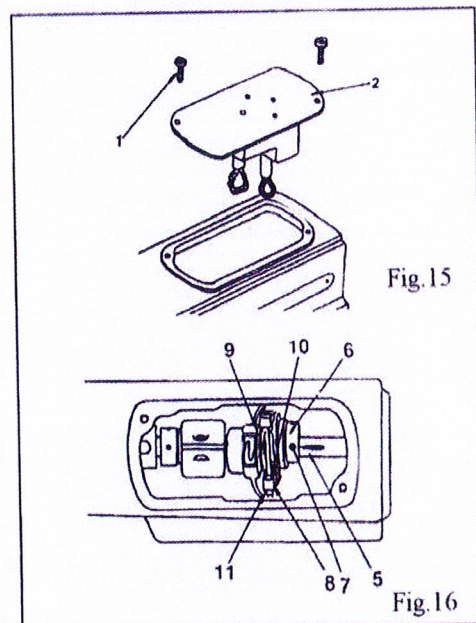

- 4) Pushing the stitch length regulating lever up and down, turn the cam 6 and set this at the point both the needle and the feed dog rest. After positioning completed, tighten the each screw securely

17. ADJUSTING THE HEIGHT OF THE NEEDLE BAR (Fig.17)

When the needle bar is at its highest point, normally the measurement between the surface of the needle plate and the upper end of the needle eye is 22.3 mm.

You can also adjust this at its lowest point. In this case, normally the measurement between the surface of the needle plate and the upper end of the needle eye is 11 mm. To adjust this, loosen the screw J (Fig.3) and raise or lower the needle bar as may be required. Then, tighten the screw upon completion of adjustment.

NOTE: These measurements are approximate standard, accordingly, following final adjustments "TIMING BETWEEN THE HOOK AND THE NEEDLE" are recommended.

18. TIMING BETWEEN THE HOOK AND THE NEEDLE (Fig.18, Fig.19)

After setting the needle bar height, set stitch length to minimum, turn the balance wheel toward you until the needle bar reaches its lowest point. Continue turning and allow the needle bar to raise about 2 mm while on its upward stroke. With needle bar in this position, the point of the sewing hook should be at the center of the needle, and normally, the measurement between the hook point and the upper end of the needle eye should be 2.4 mm. Further the clearance between the hook point and the needle hollow should be about 0.05 to 0.1 mm.

1) If the sewing hook should not be timed correctly, loosen the three set screws. Turn the hook shaft to align the hook point with the center of the needle. Re-tighten the three set screws and re-check the timing of the sewing hook.

2) To adjust the clearance between the hook point and the needle hollow, loosen the two screws and move the hook to the right or to the left as may require. Please note one of the two screws is placed on the V ditch of hook shaft. Therefore, keep the screw on V ditch during adjustment. Re-tighten the screws.

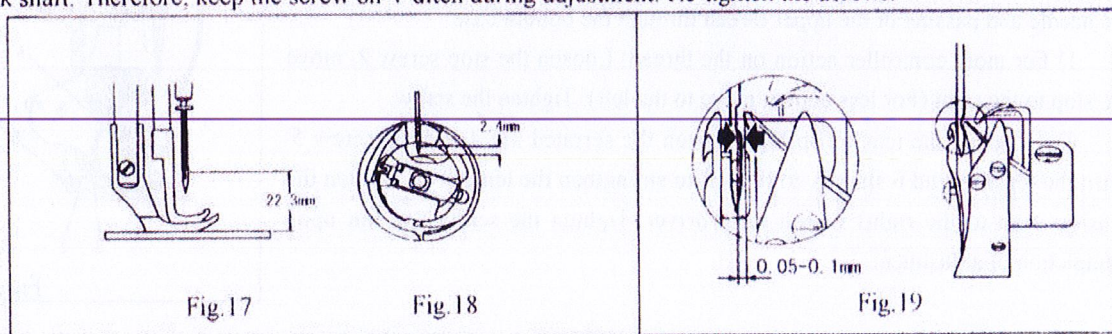

19. ADJUSTING THE HEIGHT OF THE PRESSER FEET (Fig.20)

1) Adjustment by the presser bar lifter. Loosen the screw 1 sufficiently, raise the presser bar lifter and loosen the set screw 2. Move the lifting presser foot up or down as may be required so as to get the correct height and tighten the screws.

2) Adjusting the lift of alternating presser feet: If the height of the lifting presser foot changes, the momentums of the lifting and vibrating presser foot vary, thus the height of the vibrating presser foot must be adjusted. To adjust this, lower the presser bar lifter, holding the vibrating presser foot B (Fig.6) and loosen the hexagon screw 3 and move the presser foot up or down as may be required. After setting the position, tighten the screw.

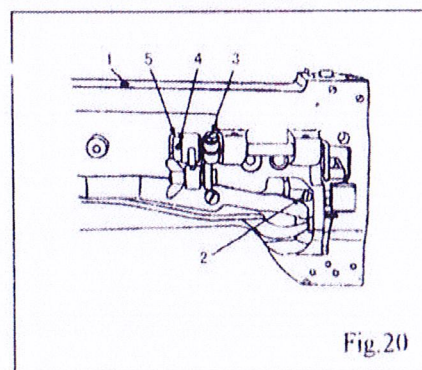

20. TIMING OF THE VIBRATING PRESSER FOOT

This is the normal timing when turn the balance wheel toward you, after lowering the presser bar lifter, the vibrating presser foot should reach the feed dog earlier than the needle eye comes to, and when the needle raises, the vibrating presser foot should leave the feed dog after the needle eye has left the feeder. This is due the reason that the vibrating presser foot must tightly hold the goods while the needle is passing the goods for avoiding irregular stitches. To adjust this, set the lift of the alternating presser feet to equal. loosen the two screws 4 (Fig.20) and adjust the rotating position of the cam 5 (Fig.20) faster or slower as may be desired, and tighten the screws.

21. ADJUSTMENT OF THE CLEARANCE BETWEEN FEED FORKED CONNECTION AND FEED FORK COLLAR (Fig.15, Fig.16)

Incorrect clearance between the fork 8 of feed forked connection and feed fork collar 9 will bring irregular stitch length or overheating, etc. To adjust this, open the cover plate. Remove the cover plate and the oil reservoir. To increase the clearance, loosen the screw and turn the screw to left or counter-clockwise. This adjustment should be done with turning the balance wheel toward you to get correct clearance. Upon completion of adjustment, tighten the screw which is loosened to touch the feed fork.

22. ADJUSTING THE THREAD CONTROLLER SPRING (Fig.21)

Normally, the thread controller spring 1 should hold slack of the upper thread until the needle reaches to the goods, and it should pause while raising of the needle and passing of the upper thread through the bobbin case.

1) For more controller action on the thread: Loosen the stop screw 2, move the stop to the right (For less action, move to the left). Tighten the screw.

2) To adjust the tension spring: Loosen the serrated nut 4 and the screw 5. Turn the tension stud 6 slightly to the left to strengthen the tension (to lighten the tension, turn to the right) with a screwdriver. Tighten the screw and nut upon completion of adjustment.

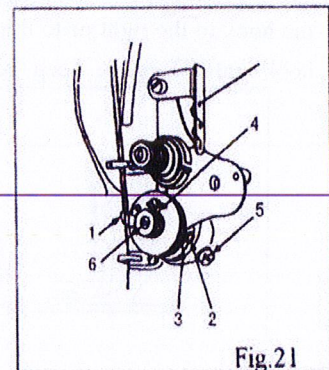

A.ARM BED AND ITS ACCESSORIES

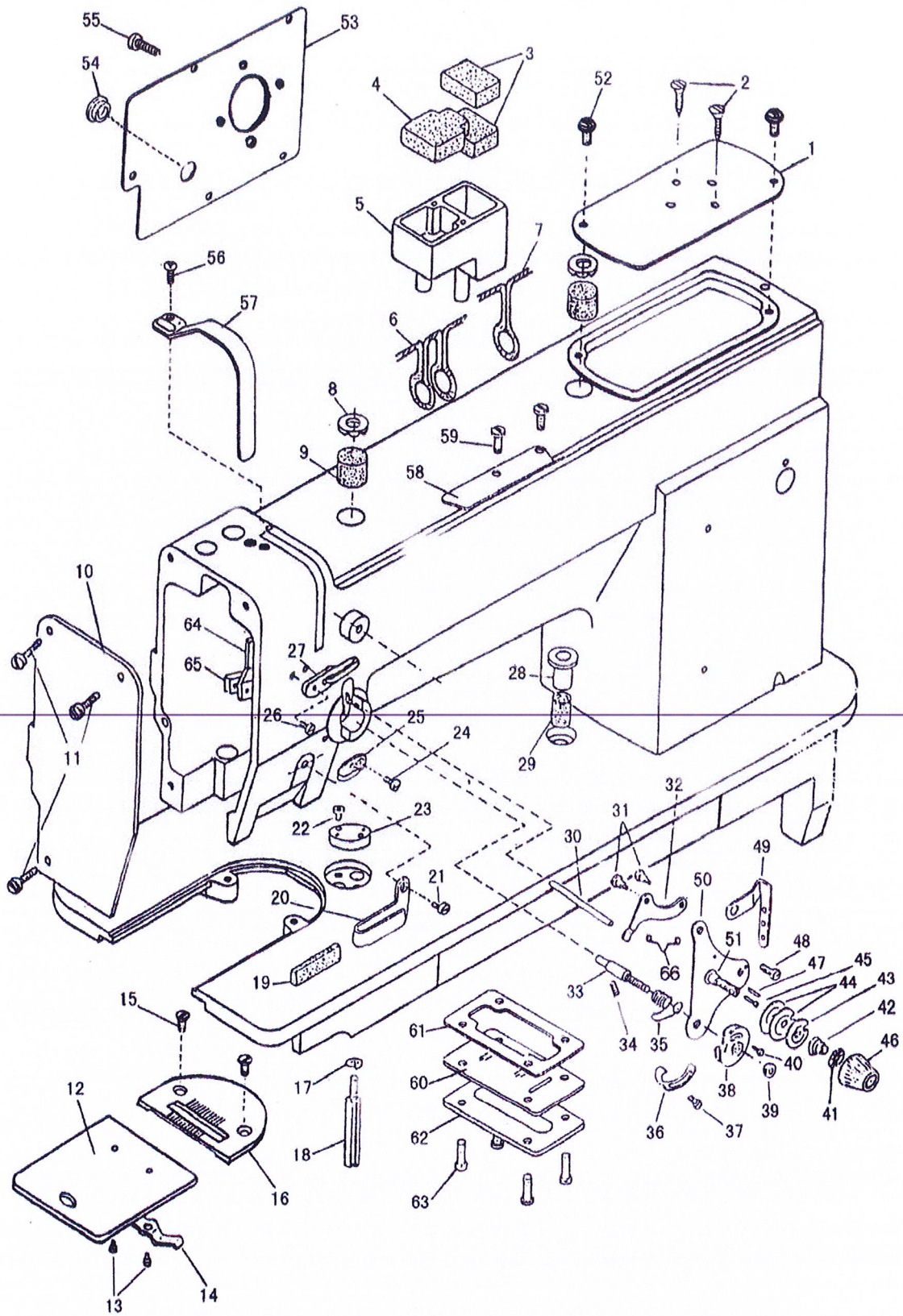

A.ARM BED AND ITS ACCESSORIES

No.	Part No.	Name	Qty	Remark
1	7.02.11.57001	Arm cover (right)	1	
2	7.02.15.163	Screw	2	
3	7.02.16.460	Felt	1	
4	7.02.16.461	Felt	2	
5	7.02.16.022	Arm oil box (right)	1	
6		Oil wick	1	
7		Oil wick	1	
8	7.02.16.023	Oil cap	1	
9		Oiling felt	1	
10	7.02.11.57101	Face plate	1	
11	7.02.15.160	Screw	2	SM11/64" (40) ×9
12	7.02.02.274	Slide plate	1	
13	7.02.15.113	Screw	2	SM3/32" (56) ×2.2
14	7.02.17.146	Slide plate spring	1	
15	7.02.15.154	Screw	2	SM11/64" (40) ×6.5
16	7.02.02.560	Needle plate	1	
17	7.02.18.058	Spring washer	1	
18	7.02.10.210	Support lever	1	
19	7.02.16.014	Felt	1	
20	7.02.14.160	Thread guide	1	
21	7.02.15.120	Screw	1	SM9/64"(40)×5
22	7.02.15.152	Screw	1	
23	7.02.13.120	Cloth guide plate	1	
24	7.02.15.120	Screw	1	
25	7.02.14.161	Thread guide	1	
26	7.02.15.114	Screw	1	
27	7.02.14.011	Thread guide	1	
28	7.02.16.040	Oil cap	1	
29	7.02.16.032	Felt	2	
30	7.02.10.531	Thread tension releasing pin (long)	1	
31	7.02.01.390-01	Screw	2	
32	7.02.01.390-02	Tension releasing plate	1	
33	7.02.01.390-03	Screw	1	
34	7.02.01.390-04	Screw	1	
35	7.02.01.390-05	Thread take-up spring	1	
36	7.02.01.390-06	Stop block	1	
37	7.02.01.390-07	Screw	1	
38	7.02.01.390-08	Thread guide	1	
39	7.02.01.390-09	Nut	1	
40	7.02.01.390-10	Set screw	1	
41	7.02.01.390-11	Stop disc	1	
42	7.02.01.390-12	Tension releasing spring	1	

B.THREAD TAKE-UP AND UPPER SHAFT MECHANISM

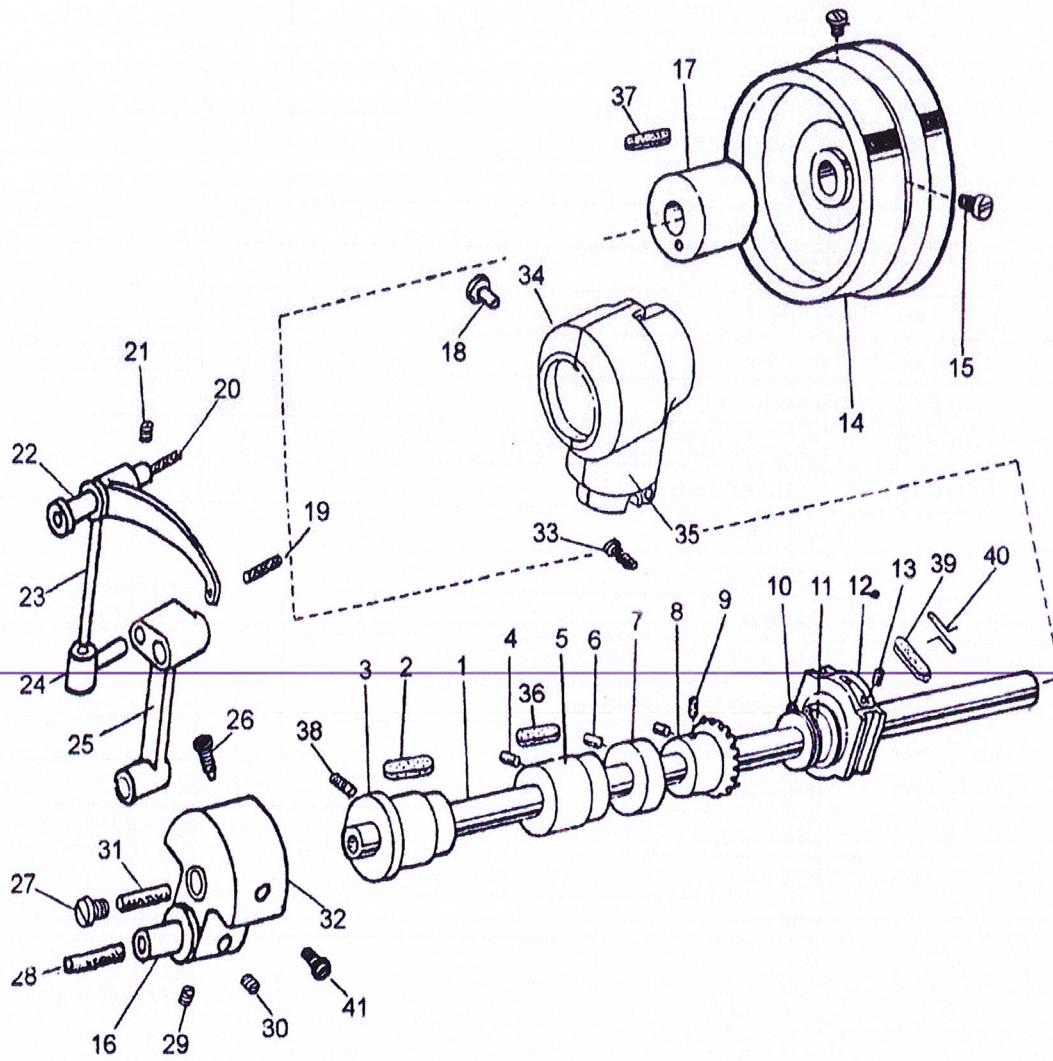

B.THREAD TAKE-UP AND UPPER SHAFT MECHANISM

No.	Part No.	Name	Qty	Remark
1	7.02.03.470	Upper shaft	1	
2	7.02.16.462	Felt	1	
3	7.02.08.520	Upper shaft bushing(left)	1	
4	7.02.15.271	Screw	1	SM15/64" (28) ×10
5	7.02.08.521	Upper shaft bushing(middle)	1	
6	7.02.15.122	Screw	2	SM1/4" (40) ×4
7	7.02.09.014	Upper shaft collar	1	
8	7.02.07.020	Bevel gear	1	
9	7.02.15.126	Screw	8	SM1/4" (40) ×7
10	7.02.18.035	C-type stop ring	1	
11	7.02.06.450	Cam	1	
12	7.02.12.015	Slide block	1	
13	7.02.15.117	Screw	2	
14	7.02.07.140	Pulley	1	
15	7.02.15.128	Screw	2	SM15/64" (28) ×12
16	7.02.10.532	Hinge pin	1	
17	7.02.08.522	Upper shaft bushing(right)	1	
18	7.02.16.028	Rubber plug	1	
19		Oil wick	1	
20		Oil wick	1	
21	7.02.15.217	Screw	1	SM15/64" (28) ×10
22	7.02.10.533	Hinge pin	1	
23	7.02.05.500	Thread take-up lever	1	
24	7.02.05.501	Slide lever	1	
25	7.02.05.502	Link lever	1	
26	7.02.15.125	Set screw	1	SM9/32" (28)
27	7.02.05.503	Screw	1	
28	7.02.	Oil wick	1	
29	7.02.15.122	Screw	1	SM1/4" (40) ×4
30	7.02.15.126	Set screw	1	SM1/4" (40) ×7
31		Oil wick	1	
32	7.02.06.451	Crank	1	
33	7.02.15.012	Screw	2	
34	7.02.16.024	Bevel gear cover (back)	1	
35	7.02.16.024	Bevel gear cover (front)	1	
36	7.02.16.462	Felt	1	
37	7.02.16.463	Felt	1	
38	7.02.15.217	Screw	1	SM15/64" (28) ×10
39	7.02.16.464	Felt	1	
40	7.02.17.020	Oil felt clamp	1	
41	7.02.15.124	Screw	1	SM9/32" (28) ×12

C. LOWER SHAFT AND VERTICAL AXIS MACHANISM

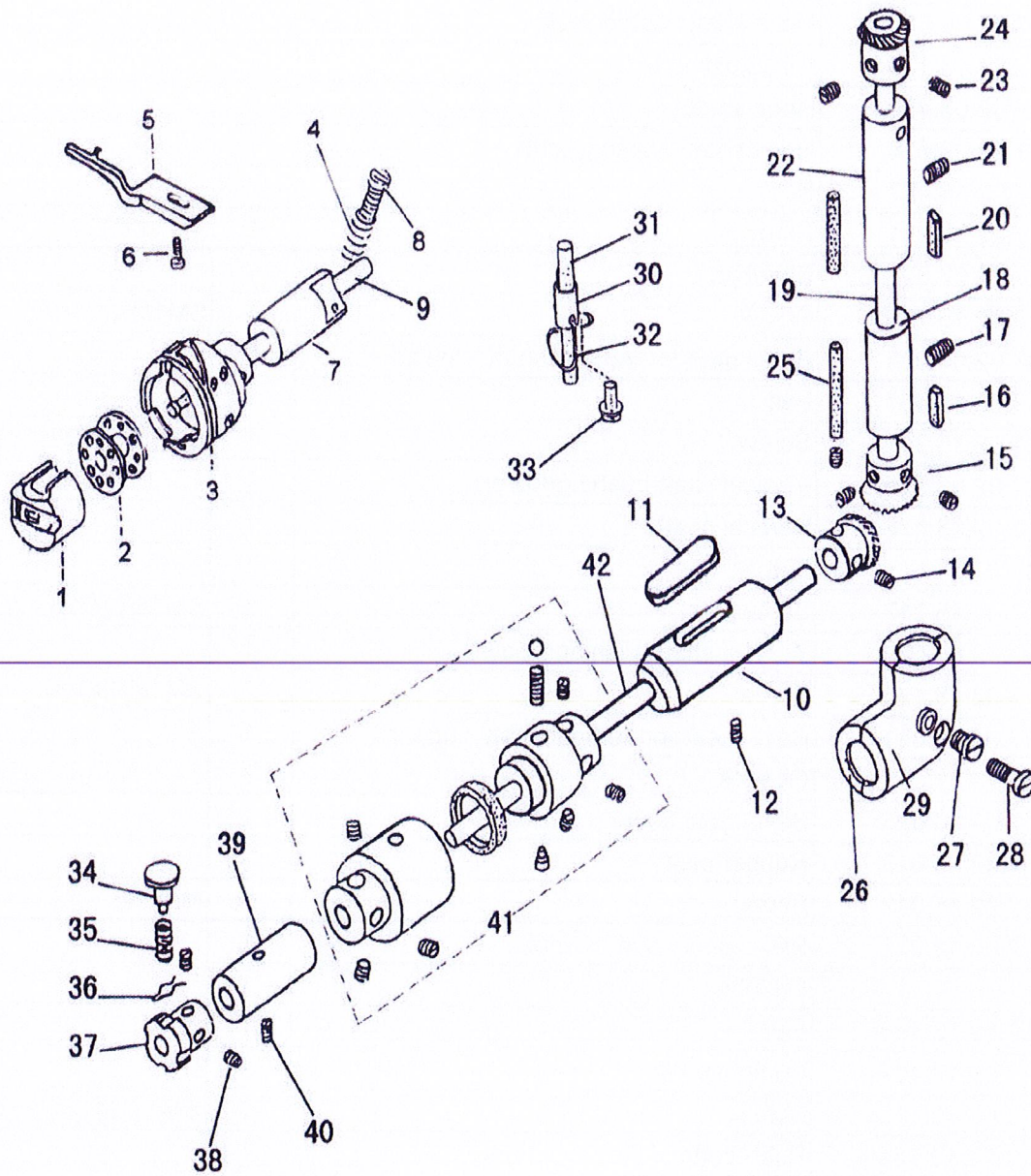

C.LOWER SHAFT AND VERTICAL AXIS MACHANISM

No.	Part No.	Name	Qty	Remark
1	7.02.02.561	Bobbin case complete	1	
2	7.02.21.211	Bobbin	1	
3	7.02.02.562	Rotating hook complete	1	
4	7.02.17.466	Spring	1	
5	7.02.14.044	Hook positioner	1	
6	7.02.15.160	Screw	1	SM11/64"(40) ×10
7	7.02.08.523	Hook shaft bushing(left)	1	
8	7.02.15.1001	Oil adjusting screw	1	
9	7.02.03.471	Hook shaft	1	
10	7.02.08.524	Hook shaft bushing(right)	1	
11	7.02.16.467	Felt	1	
12	7.02.15.251	Screw	1	SM11/64"(40) ×8.5
13	7.02.07.024	Bevel gear	1	
14	7.02.15.126	Screw	4	SM1/4"(40)×7
15	7.02.07.023	Bevel gear for vertical shaft (lower)	1	
16	7.02.16.467	Felt	1	
17	7.02.15.217	Screw	1	SM15/64"(28) ×10
18	7.02.08.525	Vertical shaft bushing(lower)	1	
19	7.02.03.472	Vertical shaft	1	
20		Felt	1	
21	7.02.15.217	Screw	1	SM15/64"(28) ×10
22	7.02.08.526	Vertical shaft bushing(upper)	1	
23	7.02.15.126	Screw	2	SM1/4"(40)×7
24	7.02.07.021	Bevel gear for vertical shaft (upper)	1	
25		Oil wick	2	
26	7.02.16.025	Bevel gear cover (back)	1	
27	7.02.16.028	Rubber plug	2	
28	7.02.15.012	Screw	1	M5×14
29	7.02.16.025	Bevel gear cover (front)	1	
30		Oil tube	1	
31	7.02.16.468	Felt	1	
32	7.02.17.467	Oil felt spring	1	
33	7.02.15.160	Screw	1	SM11/64"(40) ×9
34	7.02.10.534	Push button	1	
35	7.02.17.468	Push button spring	1	
36		Stop ring	1	
37	7.02.08.528	Ratchet wheel	1	
38	7.02.15.1002	Screw	2	SM1/4"(40)×6
39	7.02.08.527	Hook shaft bushing(middle)	1	
40	7.02.15.1003	Screw	1	SM11/64"(40) ×8.5
41	7.02.01.391	Safety clutch complete	1	
42	7.02.03.473	Hook shaft (right)	1	

D. STITCH REGULATOR MECHANISM

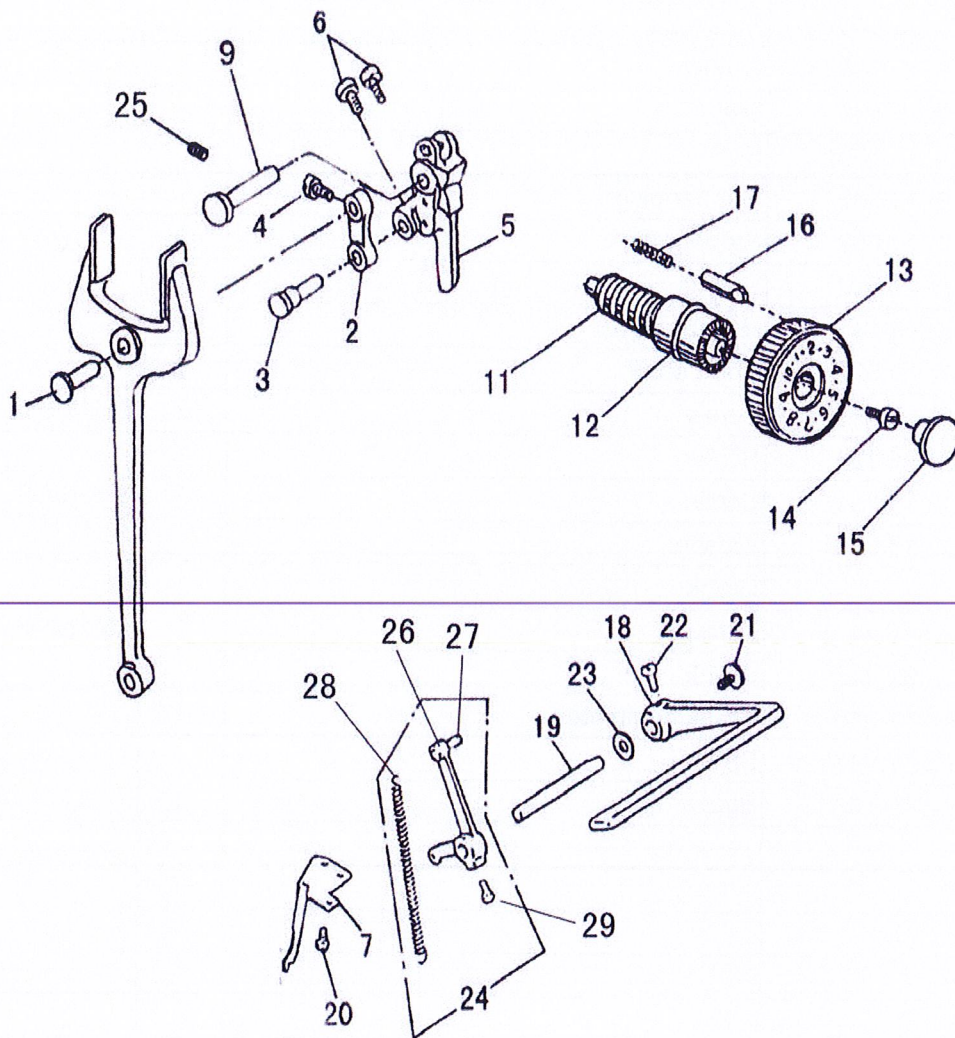

E. LOWER FEEDING MECHANISM

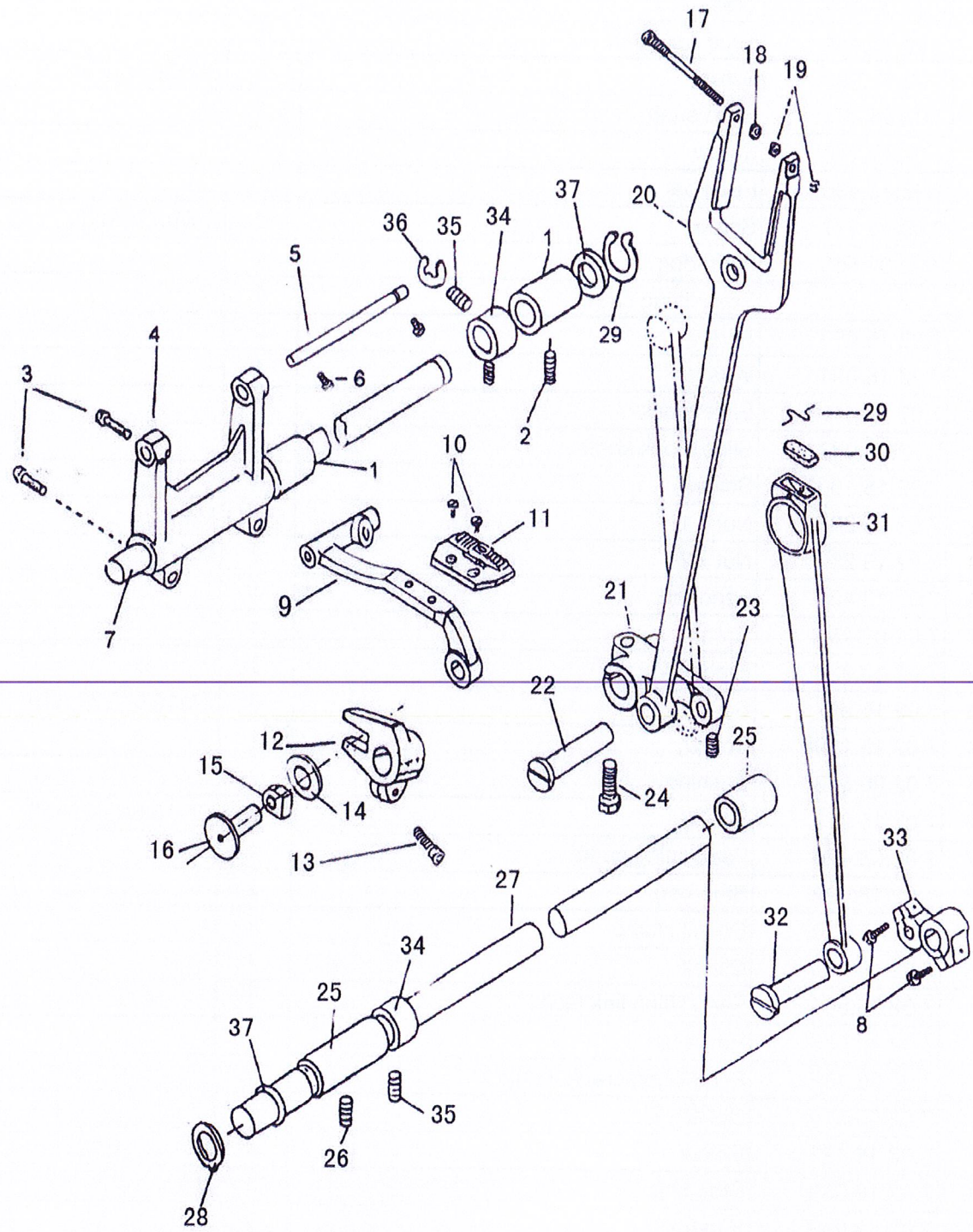

E.LOWER FEEDING MECHANISM

No.	Part No.	Name	Qty	Remark
1	7.02.08.529	Feed shaft bushing	2	
2	7.02.15.217	Screw	2	SM15/64"(28)×10
3	7.02.15.243	Screw	2	
4	7.02.06.454	Crank	1	
5	7.02.03.474	Feed bar shaft	1	
6	7.02.15.238	Screw	2	SM15/64"(28)×10
7	7.02.03.475	Feed shaft	1	
8	7.02.15.148	Screw	2	
9	7.02.13.430	Feed bar	1	
10	7.02.15.177	Screw	2	SM1/8"(44)×6
11	7.02.02.565	Feed dog	1	
12	7.02.06.455	Feed lifting crank (left)	1	
13	7.02.15.053	Screw	2	
14	7.02.18.351	Washer	1	
15	7.02.12.310	Slide block	1	
16	7.02.10.537	Slide block shaft	1	
17	7.02.15.1005	Screw	1	
18	7.02.15.268	Nut (1)	1	M4
19	7.02.15.266	Nut (2)	2	M3
20	7.02.13.431	Feed fork	1	
21	7.02.06.456	Crank	1	
22	7.02.10.033	Hinge pin	1	
23	7.02.15.217	Screw	3	SM15/64"(28)×10
24	7.02.15.1006	Screw	1	
25	7.02.08.063	Bushing	2	
26	7.02.15.217	Screw	2	SM15/64"(28)×10
27	7.02.03.476	Feed lifting shaft	1	
28	7.02.18.022	Stop ring	2	
29	7.02.17.020	Oil felt clamp	1	
30	7.02.16.469	Oil felt	1	
31	7.02.05.504	Feed lifting link lever	1	
32	7.02.10.033	Hinge pin	1	
33	7.02.06.137	Feed lifting crank (right)	1	
34	7.02.09.014	Collar	2	
35	7.02.15.122	Screw	4	SM1/4"(40)×4
36	7.02.18.039	Stop ring	1	Φ5
37	7.02.18.038	Washer	2	

F.NEEDLE BAR FEEDING MECHANISM

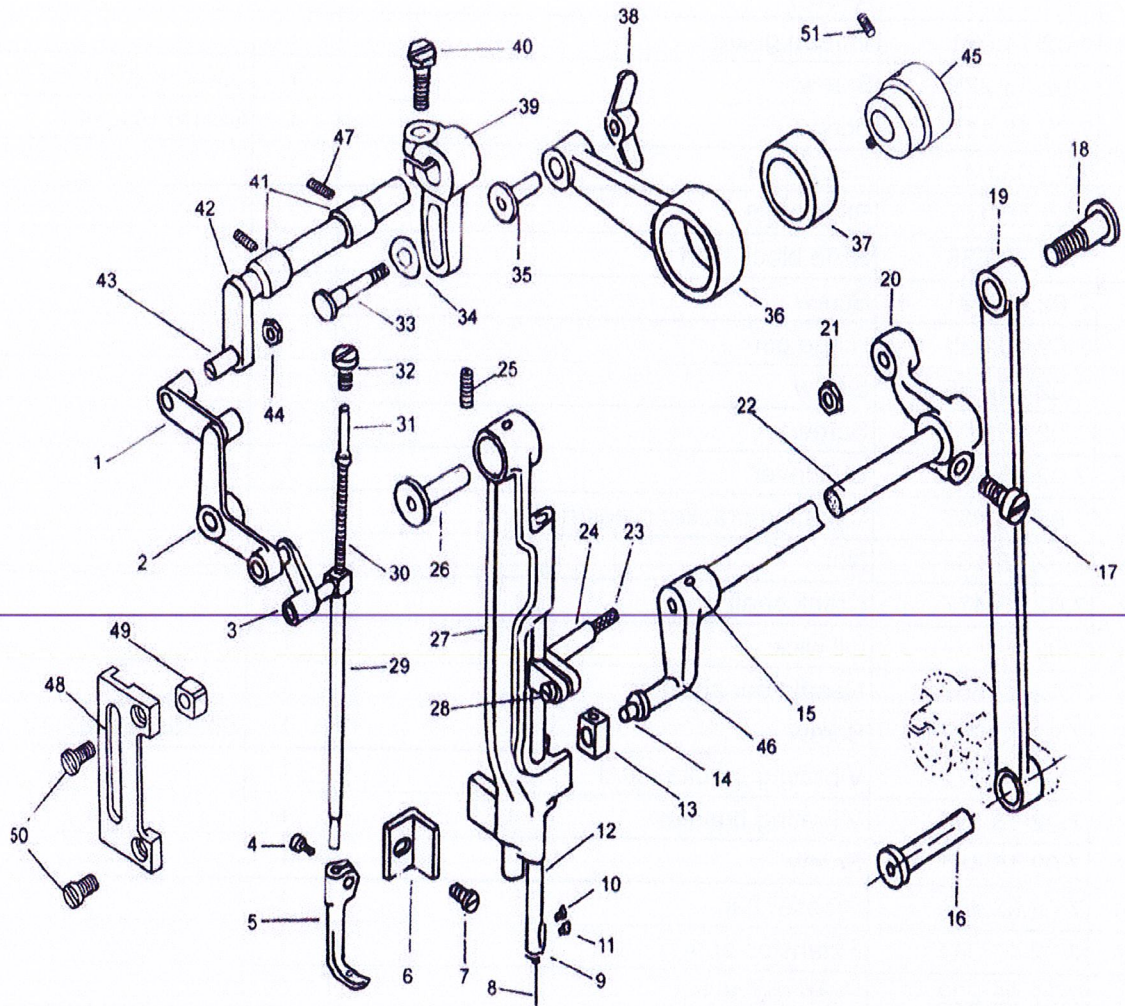

F.NEEDLE BAR FEEDING MECHANISM

No.	Part No.	Name	Qty	Remark
1	7.02.05.233	Crank link lever	1	
2	7.02.11.244	Presser foot lifting lever	1	
3	7.02.05.234	Link lever	1	
4	7.02.15.628	Screw	1	
5	7.02.02.566	Presser foot	1	
6	7.02.11.240	Pressplate	1	
7	7.02.15.178	Screw	1	
8	7.02.21.210	Needle	1	DP×17 22#
9	7.02.14.021	Thread guide	1	
10	7.02.15.229	Screw	1	SM3/32"(56)×2.5
11	7.02.15.118	Screw	1	SM1/8"(44)×4.5
12	7.02.03.041	Needle bar	1	
13	7.02.12.141	Slide block	1	
14	7.02.10.538	Slide block stud	1	
15	7.02.10.021	Screw	1	
16	7.02.10.033	Hinge pin	1	
17	7.02.15.205	Screw	1	
18	7.02.15.1007	Screw	1	
19	7.02.05.505	Link lever	1	
20	7.02.06.457	Vibrating bracket crank(right)	1	
21	7.02.15.464	Nut	1	
22	7.02.03.477	Crank shaft	1	
23	7.02.	Oil wick	1	
24	7.02.02.567	Needle bar adaptor	1	
25	7.02.15.217	Screw	1	SM15/64"(28)×10
26	7.02.10.272	Vibrating bracket stud	1	
27	7.02.13.194	Vibrating bracket	1	
28	7.02.15.481	Screw	1	
29	7.02.03.478	Presser bar	1	
30	7.02.17.044	Extension spring	1	
31	7.02.05.232	Push rod assy.	1	
32	7.02.15.1008	Screw	1	
33	7.02.15.705	Hinge shaft	1	
34	7.02.18.049	Washer	1	
35	7.02.08.293	Hinge bushing	1	
36	7.02.05.506	Eccentric link lever	1	
37	7.02.04.170	Needle bearing	1	
38	7.02.15.688	Nut	1	
39	7.02.06.173	Adjusting crank	1	
40	7.02.15.1009	Screw	1	
41	7.02.08.530	Presser foot lifting shaft bushing	2	SM11/64"(40)×5.5
42	7.02.03.219	Presser foot lifting shaft	1	

G.PRESSER FOOT MECHANISM

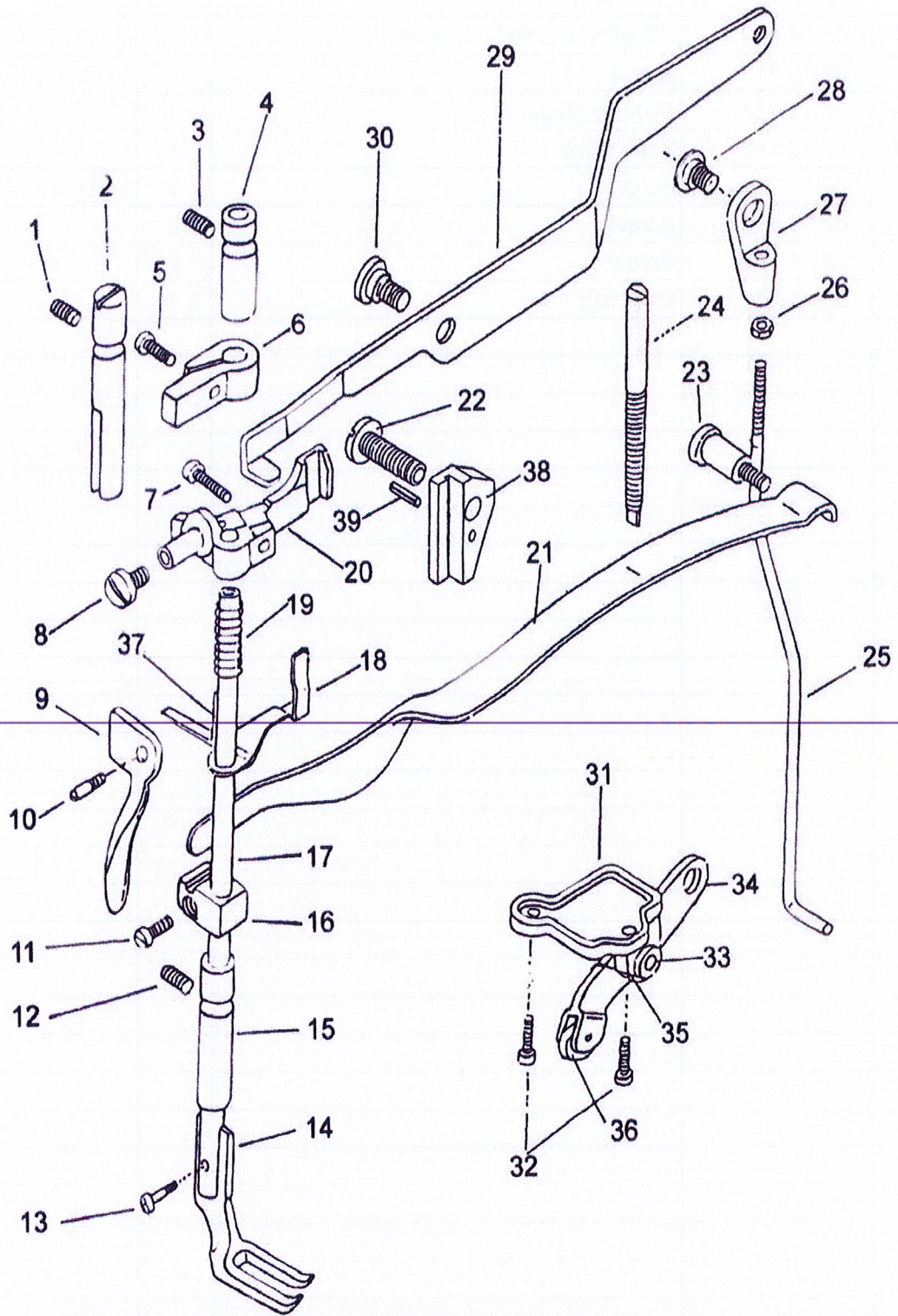

G.PRESSER FOOT MECHANISM

No.	Part No.	Name	Qty	Remark
1	7.02.15.217	Screw	1	
2	7.02.03.218	Guide post	1	
3	7.02.15.217	Screw	1	
4	7.02.08.290	Bushing(upper)	1	
5	7.02.15.250	Screw	1	
6	7.02.13.195	Guide bracket	1	
7	7.02.15.147	Screw	1	
8	7.02.15.708	Screw	1	
9	7.02.05.229	Presser foot lever	1	
10	7.02.15.1010	Screw	1	
11	7.02.15.231	Screw	1	
12	7.02.15.217	Screw	1	
13	7.02.15.230	Screw	1	SM9/64" (40) ×6
14	7.02.02.043	Walking presser foot	1	
15	7.02.08.291	Bushing(lower)	1	
16	7.02.12.030	Spring bracket	1	
17	7.02.03.040	Presser bar	1	
18	7.02.11.242	Thread releasing bracket	1	
19	7.02.17.042	Spring	1	
20	7.02.13.196	Presser bar lifting bracket	1	
21	7.02.17.262	Spring	1	
22	7.02.15.221	Screw	1	SM1/4"(24)×20
23	7.02.15.227	Screw	1	
24	7.02.15.1011	Screw	1	
25	7.02.17.469	Connecting rod	1	
26	7.02.15.168	Nut	1	
27	7.02.05.029	Connecting rod joint	1	
28	7.02.15.1012	Screw	1	
29	7.02.17.470	Knee lifting lever	1	
30	7.02.15.1013	Screw	1	
31	7.02.06.460	Knee lifting crank base	1	
32	7.02.15.147	Screw	1	
33	7.02.10.539	Pin	2	∅ 5×18
34	7.02.06.461	Knee lifting crank	1	
35	7.02.17.471	Spring	1	
36	7.02.12.311	Pin roller	1	
37	7.02.03.479	Guide rod	1	
38	7.02.11.241	Guide plate	1	
39	7.02.10.540	Spring pin	1	∅ 3×18

H.ACCESSORIES

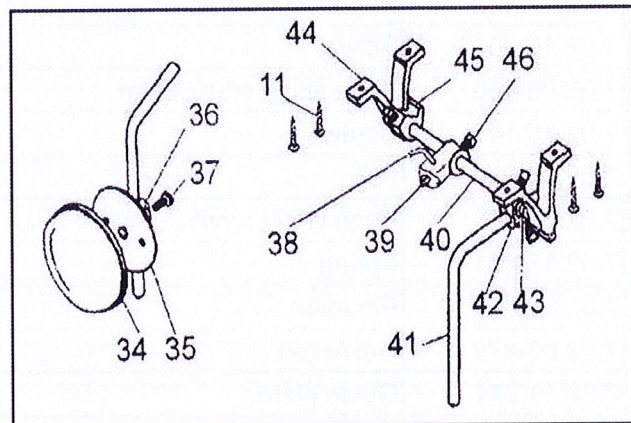
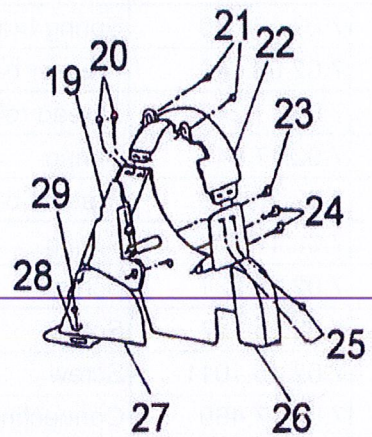
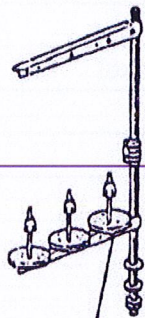
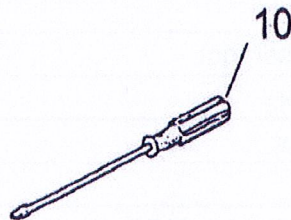
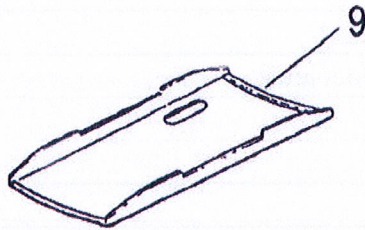
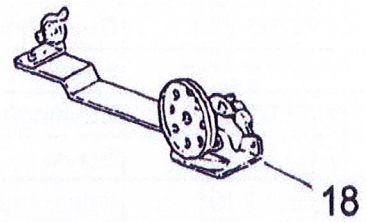
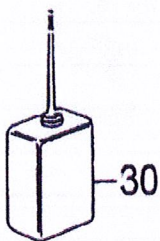
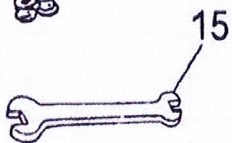
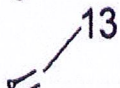
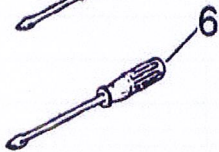
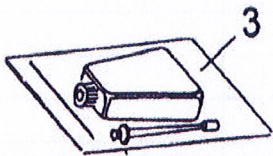
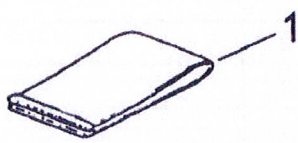

17

H.ACCESSORIES

No.	Part No.	Name	Qty	Remark
1	7.02.21.223	Vinyl cover	1	
2	7.02.21.079(080)	Hinge	2	
3	7.02.21.076	Oiler(small)	1	
4	7.02.21.210	Needle	1	DP×17 22#
5	7.02.21.001	Screw driver (small)	1	
6	7.02.21.002	Screw driver (middle)	1	
7	7.02.21.500	Rubber cushion(small)	2	
8	7.02.21.501	Rubber cushion (large)	2	
9	7.02.21.502	Oil pan assy.	1	
10	7.02.21.003	Screw driver (large)	1	
11	7.02.21.033	Screw	4	4.5×20
12	7.02.21.139	Washer	2	
13		Nail	10	
14	7.02.21.211	Bobbin	3	
15	7.02.21.212	Spanner	1	
16	7.02.21.050	Thread stand	1	
17		Knee lifting assy.	1	
18	7.02.21.048	Bobbin winder assy.	1	
19	7.02.	Belt cover	1	
20	7.02.15.160	Screw	2	SM11/64"(40)×8
21	7.02.15.160	Screw	2	SM11/64"(40)×8
22		Belt cover standard component	1	
23		Screw	1	M4×12.5
24	7.02.204	Screw	2	
25		Screw	2	
26		Belt cover (lower)	1	
27		Belt cover assy.	1	
28	7.02.21.139	Washer	2	
29	7.02.21.033	Screw	2	4.5×20
30		Oiler(middle)	1	
31		Oiler	1	
32		Thread take-up spring	1	
34	7.02.21.067	Touch block	1	
35	7.02.21.068	Touch block pad	1	
36	7.02.21.069	Touch block bracket	1	
37	7.02.21.070	Screw	1	
38	7.02.21.063	Presser foot lifting bend lever	1	
39	7.02.21.06201	Knee lifting orientation block	1	
40	7.02.21.059	Knee lifting shaft	1	
41	7.02.21.061	Bend lever	1	
42	7.02.21.06001	Bend lever joint	1	
43		Spring	1	
44	7.02.21.05801	Knee lifting bracket	2	
45		Knee lifting orientation block assy.	1	
46	7.02.21.064	Screw	4	

