

WF 1526 - 33 - AUT / PARTS MANUAL / ENGLISH

GLOBAL

Our experience. Your success



目录 (Parts book)

使用说明	1
1. 机器简介 (Brief Introduction)	2
2. 主要技术规格 (Specification)	2
3. 安装 (Assembling)	3
4. 皮带张力的调整 (Adjustment of belt tension)	3
5. 皮带罩的安装 (Assembling for belt cover)	4
6. 加油 (Oiling)	4
7. 调节旋梭油量 (Adjustment for oiling amount of hook)	5
8. 油量调节 (Oil regulation)	6
9. 机针的安装 (Assembling for the needle)	6
10. 底线的穿线方法 (Threading for the buttom thread)	6
11. 灯与开关 (Lights and switches)	7
12. 绕底线 (Thread wrapping)	7
13. 穿线 (Threading)	8
14. 线迹长度的调节 (Ajustment of stitch length)	8
15. 线张力的调节 (Tension adjustment)	9
16. 压脚提升 (16.Presser foot lifting)	9
17. 压脚压力的调节 (Adjustment for pressure of presser foot)	10
18. 旋梭针座的调整 (Adjustment for needle base of the hook)	10
19. 安全装置的复位 (Restoration for the safety)	11
20. 分线钩的调节 (Adjustment for stitch length)	11
21. 针与旋梭的关系 (Relation of needle and hook)	12
22. 按钮的使用 (Use of buttons)	13
23. 缝制速度一览表 (Sewing speed schedule)	14
24. 缝制中出现的问题及处理方法 (Problem and method)	14

目录 (Partsbook)

零件手册	16
1. 外部装置 (Frame & miscellaneous cover)	17
2. 挑线及上轴部件 (Upper shaft, lower shaft driving & balance components)	19
3. 针杆摆动机构 (Needle bar rocking)	21
4. 上送料机构 (Pressure adjusting & upper feed mechanism)	23
5. 送料机构 (Feed mechanism)	27
6. 旋梭下轴机构 (Hook shaft & upper feed mechanism)	31
7. 切线机构 (Thread cutting components)	33
8. 夹线机构 (Thread tension components)	35
9. 绕线装置 (Lower thread winder mechanism component)	37
10. 供油装置 (Lubrication components)	39
11. 自动抬压脚下装置 (Automatic presser lifting mechanism)	41
12. 线架 (Thread stand components)	42
13. 自动倒缝装置 (Automatic back components)	43
14. DL装置 (DL mechanism components)	44
15. 供气装置 (Air mechanism components)	45
16. 附件 (Accessories parts components)	46
17. 气管连接图 (Tracheal connection graph)	47
18. 附表: 针位 (Needle guage)	48

使用说明

1. 机器简介

本机采用独特的三同步送料机构，使其爬坡性能优越，对厚料送布能力强，顺畅，线迹均匀，整齐，美观。采用自润滑大旋梭勾线，滑杆机构挑线，上下轴同步带传动，保证了该机高速低噪音的性能。

该产品广泛适用于汽车坐垫，沙发，皮包，帐篷等厚料的缝制。

1. Brief Introduction

The machine adopts three synchronous feeding and special feed dog construction to make the grade ability perform well. Therefore, the strong feeding ability for heavy duty material can sew smooth, average, neat and beautiful stitch. It adopts large hook, slider thread taking-up, upper and lower axis synchronous belt transmission, so that it make sure low noisy in high speed.

The machine is applied in the carseat mats, sofa, leather bags, tents and so on.

2. 主要技术规格

适应范围	厚料
最高缝纫速度	2200s. p. m
最大线迹长度	9mm
针杆行程	38mm
采用机针	DPX17 (Nm125~Nm180) 标配Nm160 (23#)
润滑方式	油线供油 (旋梭自动加油)
采用旋梭	自动润滑大旋梭
压脚高度	手动9mm, 膝控16mm
电动机功率750W	电动机功率750W

2. Specification

Appilication	heavy duty
Max sewing speed	2200spm
Max sitich length	9mm
Needle bar stroke	38mm
Needle type	DPX17 (Nm125~Nm180) Standard Nm160 (23#)
Lubrication	by oil line (automatic oiling of hook)
Hook	Self-lubricating hook
Presser foot height	Manual 9mm Knee control 16mm
Motor power	750W

3. 安装 (见图1)

1) 机壳台板连接钩座、机壳橡皮垫等的安装

用钉③把附属的连接钩座①、机壳橡皮垫②固定到台板上。

2) 油盘的安装

用8个木螺丝按图示位置把油盘④固定到台板上。

3. Assembling (Picture 1)

1) Assembling for connector of machine head and table, machine head rubber mats, and so on. Connect the screw 3 to the hookbase 1, and the rubber mat 2 fix on the table.

2) Assembling for oil tray .

Fix the oil tray on the table as the showing position by eight wood screws.

4. 皮带张力的调整 (见图2)

调整皮带张力时, 请移动马达的高度, 用9.8N的力量按压皮带中间, 此时的松弛量应为15mm。

注意: 调整前先关闭电源, 确认马达停止转动后再进行。

4. Adjustment of belt tension

To adjust the belt tension, pls move the motor height, and use the pressing power 9.8N to press at the middle of the belt, then the looseness amount would be 15mm.

Remark: please close the power before adjustment, make sure the motor stop running.

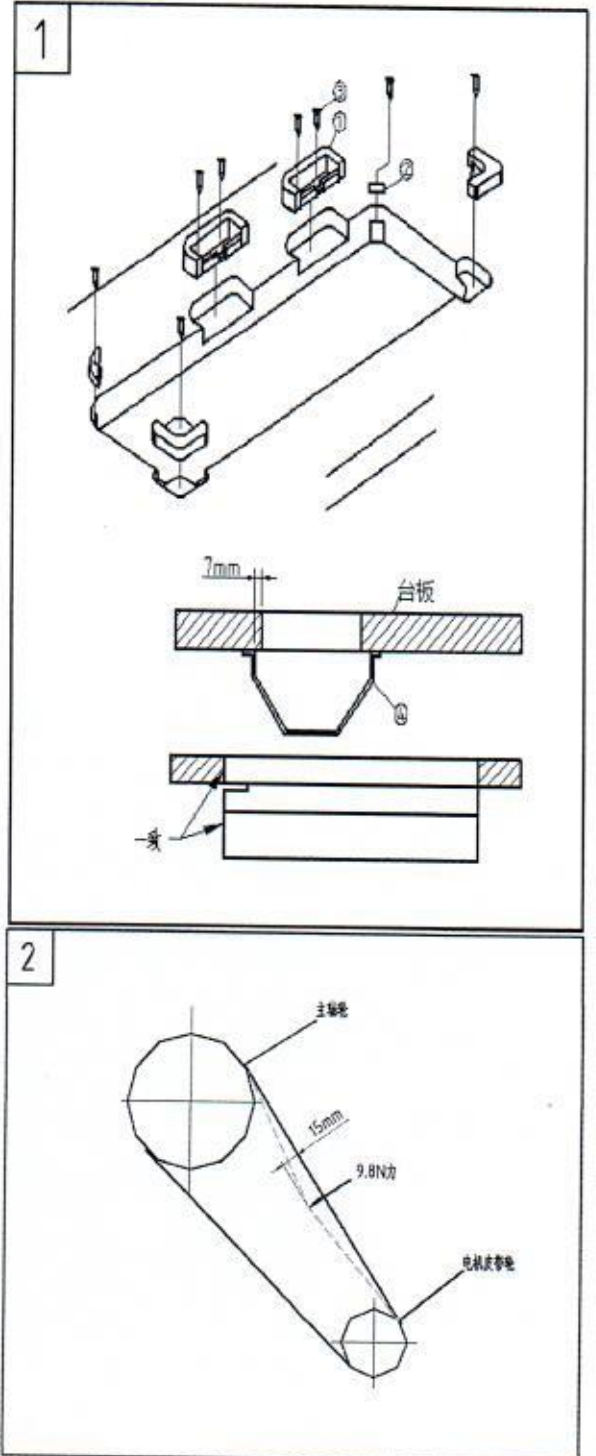

5. 皮带罩的安装 (见图3)

- 1) 把皮带罩支柱⑦拧到机头的螺钉孔上。
- 2) 用固定螺丝②⑧把皮带罩 (右) ①安装到头上。
- 3) 把皮带罩 (左) ③镶到皮带罩 (右) ①的爪部AB上。
- 4) 用固定螺丝④⑤⑥固定好皮带罩 (左) ③。

5. Assembling for belt cover

- 1) Wrest the belt cover brace 7 to the screw hole of the machine head.
- 2) Use the fixing screw 2 and 8 to fix the belt cover (right) 1 on the machine head.
- 3) Put the belt cover (left) 3 on the AB part of belt cover (right) 1.

- 4) Fix the screw 4, 5 and 6 to the belt cover (left) 3.

Remark: when finishing assembling, please confirm the belt cover can not touch the belt and main wheel.

3

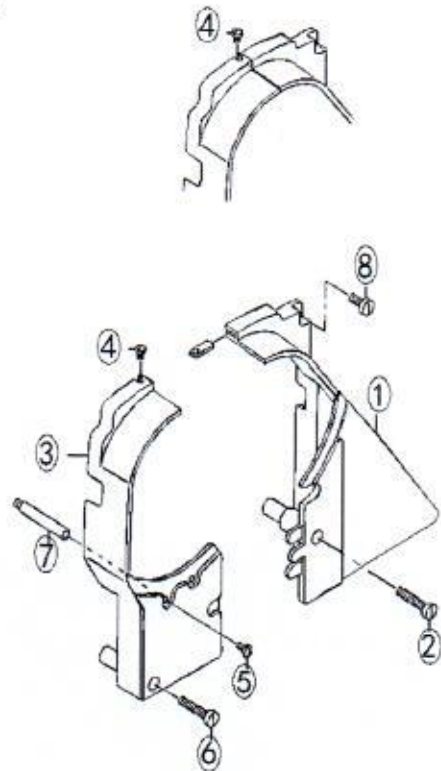

6. 加油

(1) . 面部加油 (见图4)

- 1) 拧下面板螺钉;
- 2) 拿下面板;
- 3) 每日在箭头指示的部位加适量的油;
- 4) 装上面板;
- 5) 拧紧螺钉。

6. Oiling

1) oiling for the front of machine head. (Picture 4)

- A. Wreast the cover screw.
- B. Remove the cover .

C. Oiling properly as the direction everyday.

D. Close the cover.

E. Wreast and tight the screw.

4

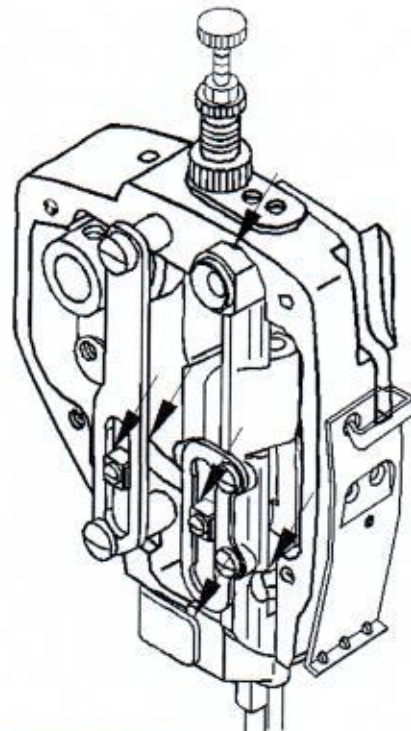

(2). 机身加油 (见图5)

- 1) 每天按箭头指示的部位加适量的油
- 2) 初次运转前或长时间没有使用时, 请在箭头指示的部位加油外, 另需卸下顶盖②, 向各毛毡和油线加适量的油
- 3) C为油面观察油仓, 可检查油泵的运行情况。

2) Oiling for machine head (Picture 5)

A. Oiling properly as the direction everyday.

B. For first running or non-use for long time, please add the oil as the direction and remove the cover 2 to add proper oil on each felt and oil line.

C.C is oil surface observation oil box. You can check the operation of the oil pump.

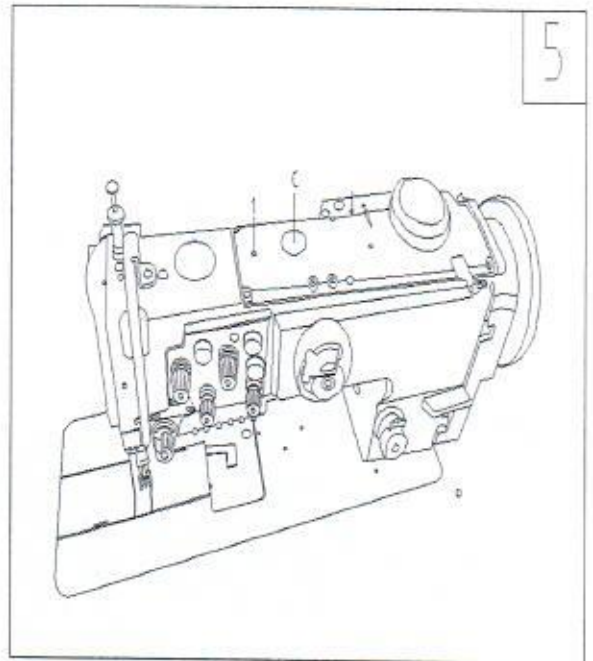

7. 调节旋梭油量 (见图6A)

1) 调节旋梭的油量时, 请拧松螺母⑩, 用油量调节螺丝⑨进行调节, 顺时针转动变少, 逆时针方向变多。

2) 把纸放到旋梭外周附近约5秒钟, 如果有了油迹如图样即为适量。

7. Adjustment for oiling amount of hook (Picture 6A)

1) When adjust the amount of the hook, please loose the nut 10. Use screw 9 to adjust. The clockwise runing will get less, and anticlockise will get more.

2) Put the paper around the hook for five seconds. Once the oil trail are shown as the picture, that means proper amount.

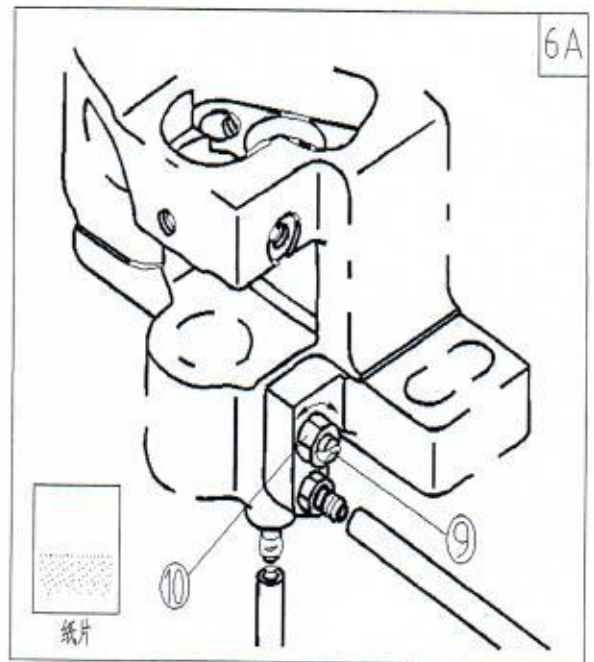

8. 油量调节 (见图6B)

当油仓油量过多时, 请拧松螺母①, 将油量调节螺丝②逆时针转动; 当油仓油量过少时, 将油量调节螺丝②顺时针转动。然后拧紧螺母。

8. Oil regulation (Picture 6B)

When oil tank oil quantity is too much, please loosen the nut, adjust the oil screw Counterclockwise rotation. When the oil is too small, please adjust the screw clockwise rotation. Then tighten the nut .

9. 机针的安装 (见图7)

- 1) 转动主动轮, 把针杆上升到量高位置;
- 2) 拧松机针固定螺丝①, 让右侧机针②的长槽朝向左, 左侧的长槽向右;
- 3) 把机针插到最里面;
- 4) 拧紧机针固定螺丝①。

9. Assembling for the needle (Picture 7)

- 1) Run the main wheel and lift the needle bar to the highest position
- 2) Loose the needle screw 1, and make the right side long slot of needle 2 direct at the left side, opposite end.
- 3) Put the needle in it.
- 4) wrest the needle and fix the screw 1.

10. 底线的穿线方法 (见图8)

- 1) 扳起旋梭的拨片①, 取梭芯;
- 2) 装入时, 正确地插入旋梭轴, 然后放倒拨片;
- 3) 把线嵌入旋梭穿线槽②, 再从突起部③的下面穿过去, 然后穿进线张力弹簧;
- 4) 拉底线之后, 梭芯沿箭头方向旋转。

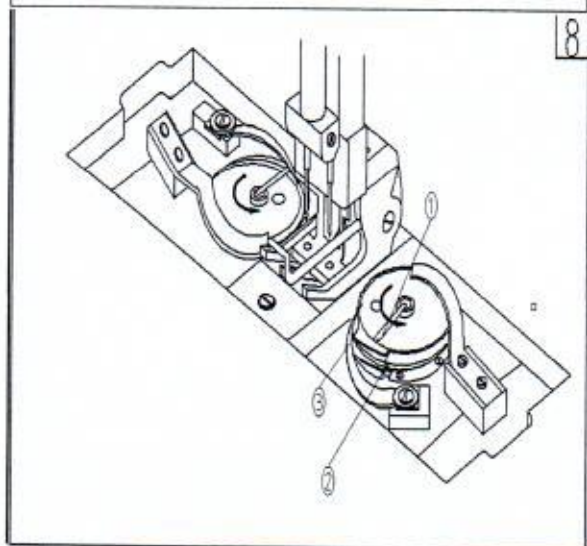
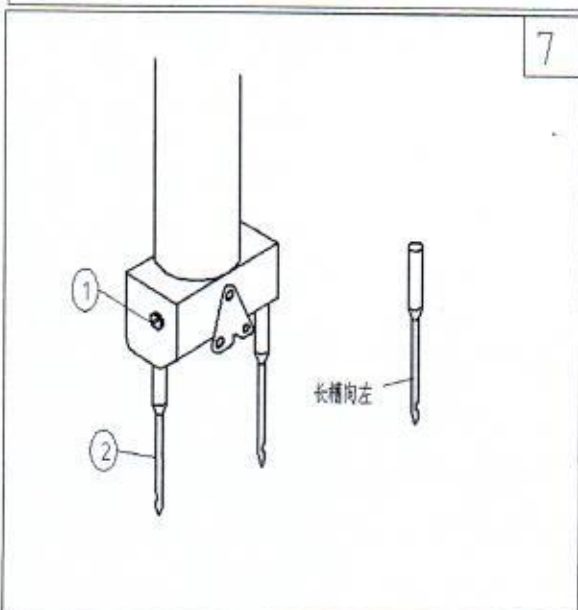
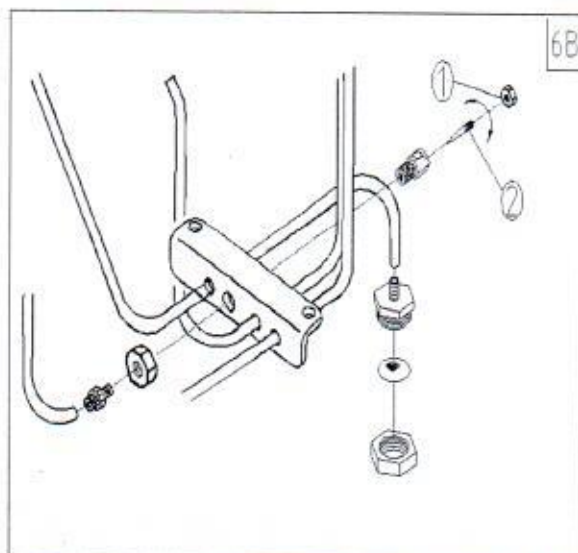

10. Threading for the bottom thread (Picture 8)

- 1) Pull the plectrum 1 of hook, and take out the bobbin.
- 2) When putting inside, insert correctly into the hook shaft, and put down the plectrum.
- 3) Inlay the thread to the threading slot 2, and put through the part 3, then pull into the tension spring.
- 4) Pull the bottom thread and the bobbin should be run as the direction in the picture.

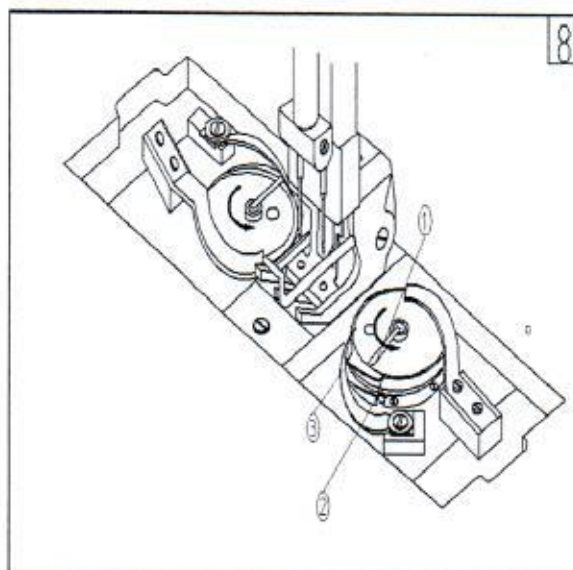

11. 灯与开关 (见图9)

左右推动开关①控制灯的开与关

11. Lights and switches

Push the switch on and off

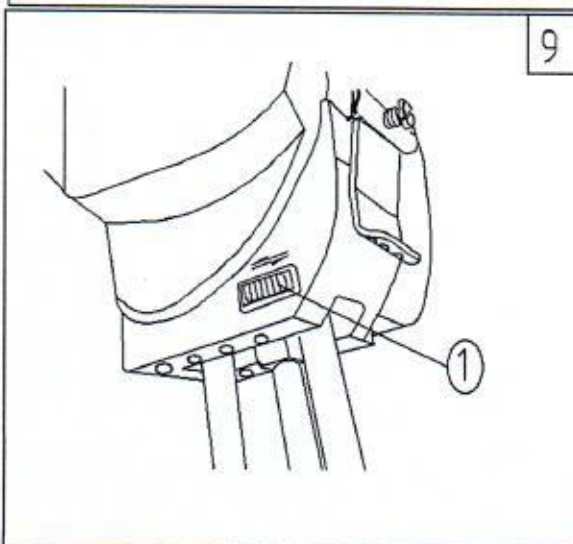

12. 绕底线 (见图10)

- 1) 按①~③的顺序穿线, 然后拿着线头从下往上将线纳入刀口切断, 新线头压在刀下。
- 2) 装上梭芯, 掀倒绕线杆A。
- 3) 拧松固定螺钉B, 调整调节板直到让线绕到80%左右的位置。
- 4) 绕线偏时, 前后移动绕线导向器C进行调整, 再用固定螺钉D固定。
- 5) 绕线结束后, 绕线杆分离, 自动停止。拨出线芯, 然后将线从下往上纳入刀口切断, 新线头压在刀下。

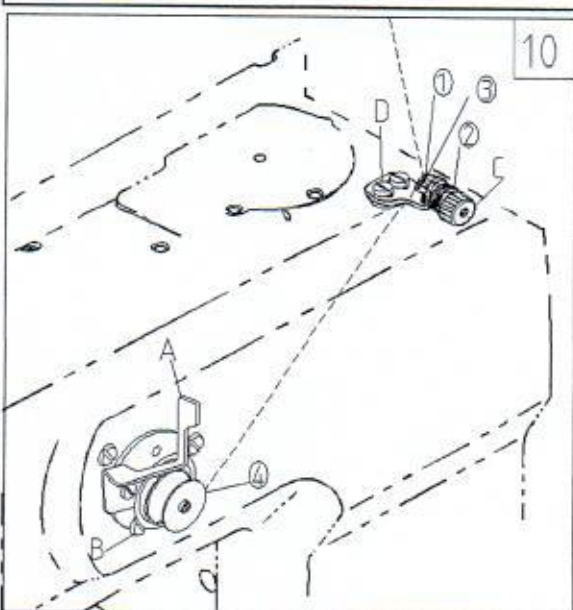

12. Thread wrapping (Picture 10)

- 1) Threading in the sequence from 1 to 3, and circle around the bobbin.
- 2) Put down the bobbin winder A.
- 3) Loose the screw B, adjust the plate to the 80% position.
- 4) When it's leaning, move the thread guide C and adjust in the front and back, then fix the screw D again.
- 5) Finish wrapping and remove the bobbin winder, it will stop automatically.

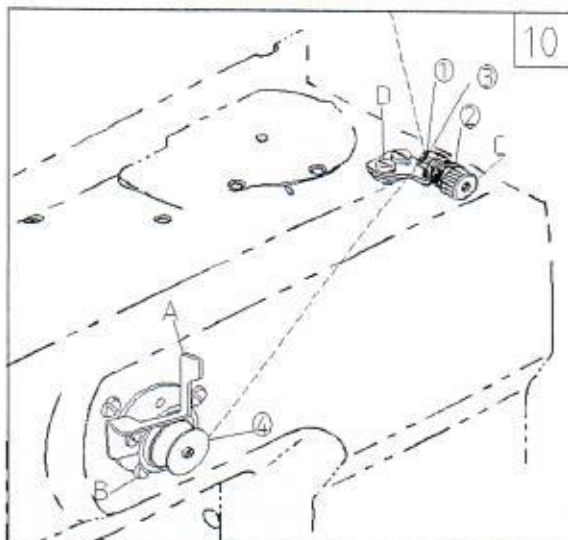

13. 穿线 (见图11)

按图示顺序穿线即可

13. Threading (Picture 11)

Threading as the sequence in the picture.

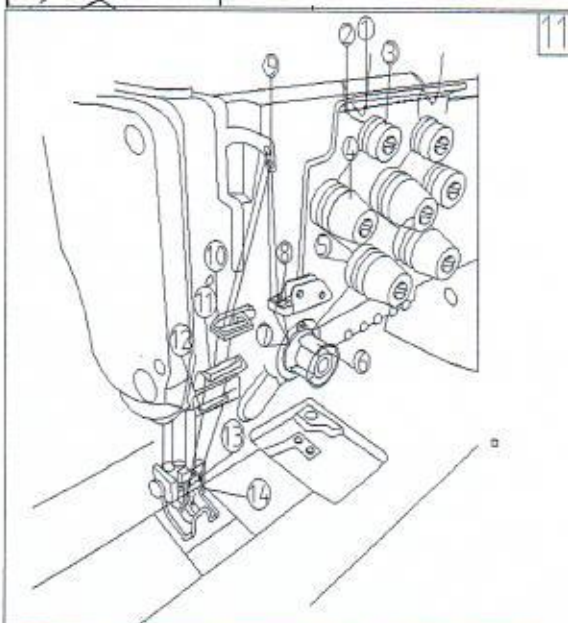

14. 线迹长度的调节 (见图12)

把送布调节盘①向左转动, 让调节器标记对准需要的数字即可;

向下按下倒缝扳手②即可开始倒缝, 放开恢复正常缝纫。

14. Adjustment of stitch length (12)

Turn the feeding adjustment tray 1 to left (right) side, make the mark on the necessary No.

Press down the bartacking handle 2 to start reverse sewing. when loose it, you can finish normal sewing.

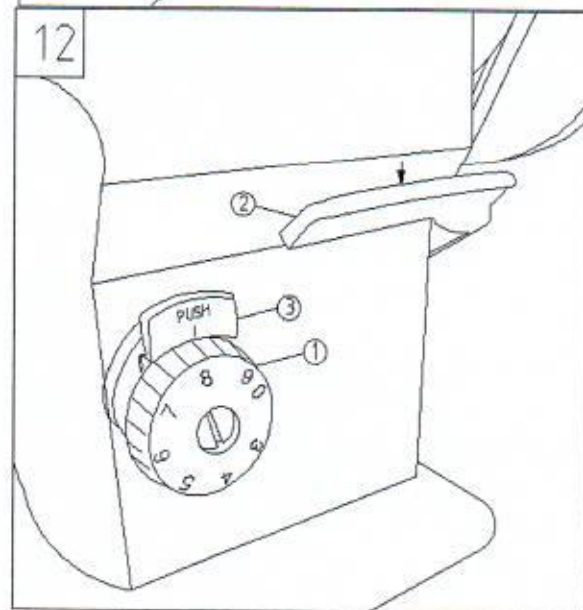

15. 线张力的调节

1) 上线张力的调节 (见图13)

顺时针方向转动线张力螺母①, 上线张力变强;
逆时针方向转动张力变弱。

2) 底线张力的调节 (见图14)

顺时针方向转动线张力螺钉②, 底线张力变强;
逆时针方向转动张力变弱。

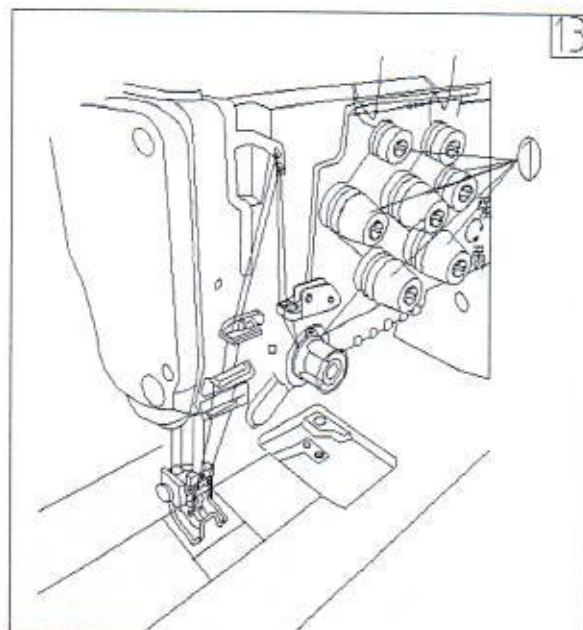

15. Tension adjustment

1) Upper Tension adjustment (Picture 13).

Turn the tension nut 1 at clockwise direction, the upper tension will stronger; at the anticlockwise direction, the tension will weaker.

2) Bottom tension adjustment (Picture 14)

Turn the tension screw 2 at the clockwise direction, the bottom tension will be stronger; at the anticlockwise direction, the tension will be weaker.

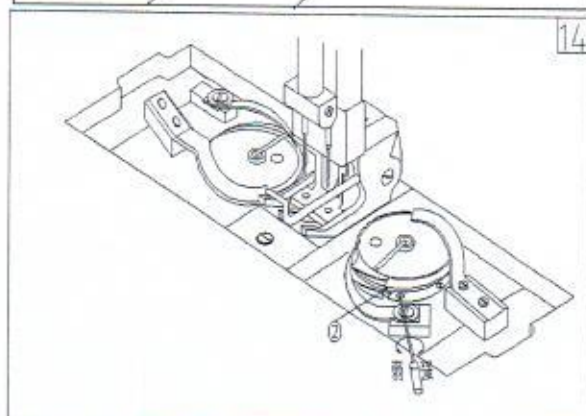

16. 压脚提升 (见图15)

1) 让压脚在上升的位置停止时, 把抬压脚扳手①向箭头方向抬起, 压脚上升9mm后停止;

2) 下降压脚时, 放下抬压脚扳手, 即返回原来位置。

16. Presser foot lifting (Picture 15)

1. Keep the presser foot at the lifting position and lift up the bar 1 at the direction in the picture, then the presser foot would lift up 9mm and stop.

2. When put down the presser foot, then let the presser handle down. It would return the original position.

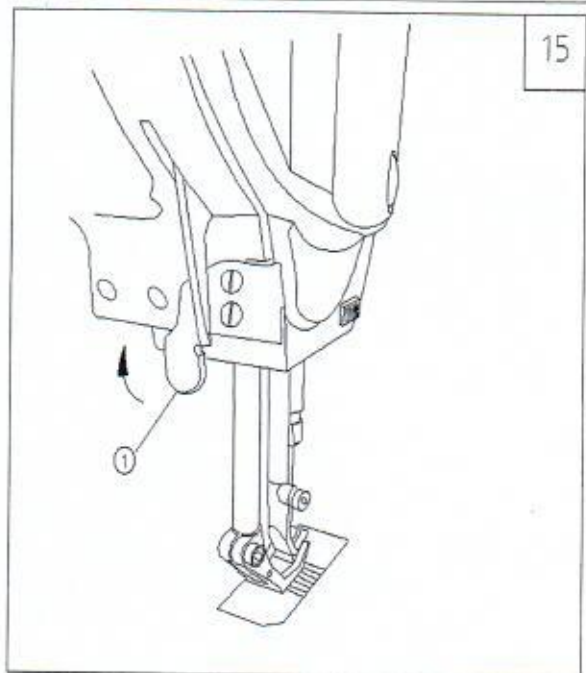

17. 压脚压力的调节 (见图16)

1) 顺时针转动压脚调节螺钉③压力变强, 逆时针转动压力变弱。调节后拧紧固定螺母④。

2) 微调压脚压力: 顺时针转动压脚调节螺钉①压力变强, 逆时针转动压力变弱。调节后拧紧固定螺母②。微调可使压脚压力更精准。

17. Adjustment for pressure of presser foot (Picture 16)

A. Turn the screw 3 at right side, the pressure would be stronger, turn left would be weaker. After adjusting, tight the fixing nut 4.

B. Fine tune: Turn the screw 2 at right side, the pressure would be stronger, turn left would be weaker. tight the fixing nut 1

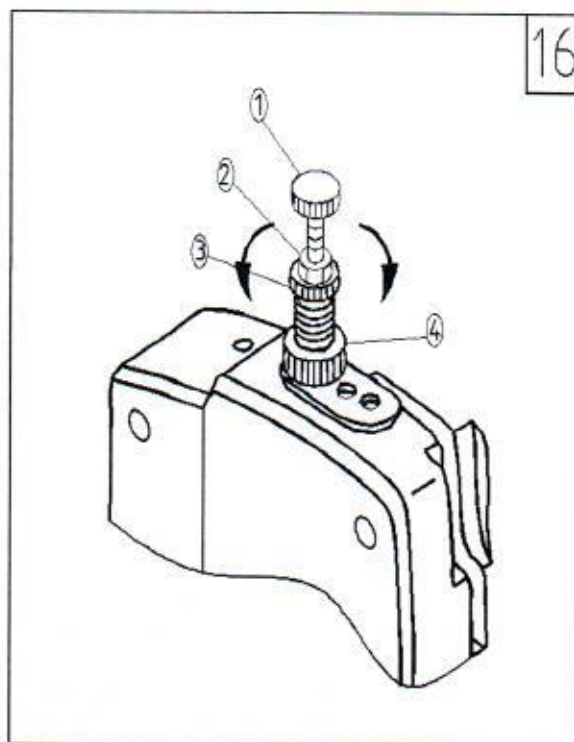

18. 旋梭针座的调整 (见图17)

更换了旋梭之后, 请确认针座位置。标准位置时, 旋梭针座②顶到机针①侧面, 离机针0.1~0.2mm的状态。如果不正确, 请弯曲旋梭针座进行调节。

1) 旋梭针座往内侧弯曲时, 把螺丝刀插到旋梭针座的外侧。

2) 旋梭针座往外侧弯曲时, 把螺丝刀插到旋梭针座的内侧。

18. Adjustment for needle base of the hook (Picture 17)

After changing the hook, please the position of the needle base. When in the standard position, needle base 2 touch the side of needle, near the needle about 0.1-0.2mm. If it's not correct, please make the needle base to curve and adjust.

1) Needle base is curve inside, insert the screwdriver into the outside of needle base.

2) Needle base is curve outside, insert the screwdriver into the inner side of needle base.

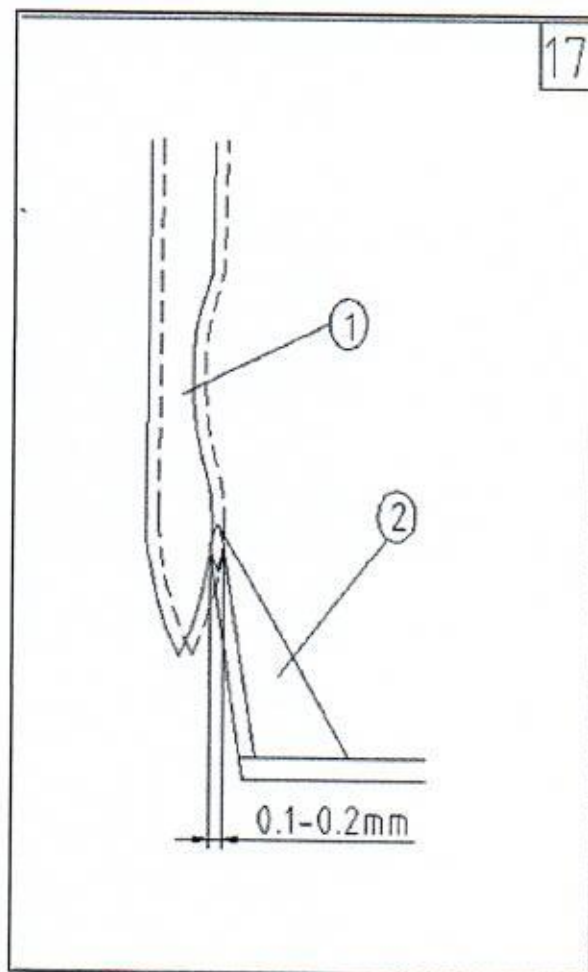

19. 安全装置的复位 (见图18)

缝制中, 如果向旋梭等施加过大的力, 安全装置就启动。这时转动主动轮旋梭也不转动, 安全装置启动之后, 请先排除故障原因, 再进行复位。

- 1) 按住机头上面的按钮①, 用力反转主动轮;
- 2) 听到“喀嚓”的声音之后, 复位完成。

注意: 完成后用手转动主动轮, 确认按钮是否复位。

19. Restoration for the safety device(Picture18)

During the sewing, the safety device will start when the hook get over pressure. Then the moving wheel hook will not work. After opening the safety device, please exclude the broken reasons and do the restoration.

- 1) Press down the button 1 of the machine head, and reverse the main wheel.
- 2) After the voice, restoration would be finished.

Remark: Turn the wheel by hand while finish, to make sure button 1 to be restoration.

20. 分线钩的调节 (见图19)

- 1) 向正常方向转动主动轮, 把分线钩①移送到最后位置。
- 2) 向箭头方向转动②, 把中旋梭止动器③顶到针板④的沟。
- 3) 拧松中导向器固定螺丝⑤, 把中旋梭导向器和梭壳的突起部A之间的间隙调整为0.1~0.3mm。

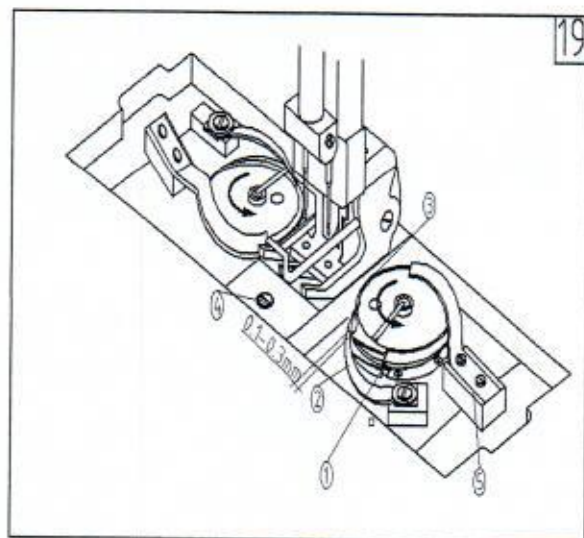
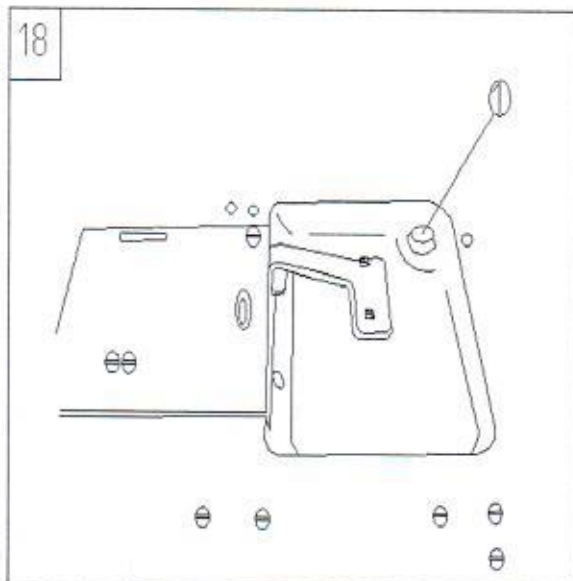

20. Adjustment for stitch length (Picture 19)

- 1) Turn the main wheel at the normal direction, move the hook guide 1 to the last position.
- 2) Turn 2 at the direction in the picture, let the stopping part 3 touch the needle slot.
- 3) Loose the screw 5, adjust the distance to be 0.1-0.3mm between hook guide and bobbin case part A.

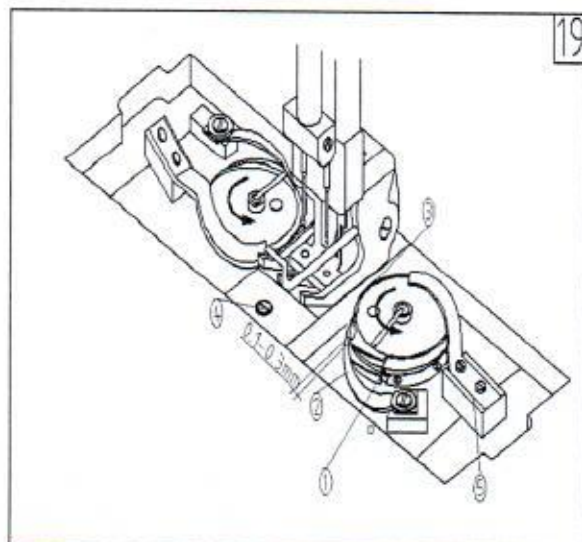

21. 针与旋梭的关系 (见图20)

- 1) 把针距调节旋钮调整到0;
- 2) 转动主动轮, 从针杆最下点上升2.3mm后, 拧松针杆接头螺丝①, 把机针②的针孔上端到梭尖③的距离调整成1.5mm, 然后再拧紧。
- 3) 转动主动轮, 把针杆从最下点上升2.3mm, 把旋梭尖③和机针②的中心调整的一致, 然后拧紧2个齿轮(小)的固定螺丝④。把2个固定螺丝④之中前端为V形的第一螺丝, 对准旋梭轴的V形沟, 然后拧紧固定。
- 4) 在旋梭尖③和机针②中心基本一致的位置, 拧松旋梭轴台的固定螺丝⑥, 左右移动旋梭轴台。把旋梭尖和机针的间隙调整为0.05~0.1mm, 然后拧紧固定螺丝⑥。
- 5) 拧松2个齿轮(大)的固定螺丝⑤, 左右移动齿轮(大), 把梭尖③机针②的中心调整为一致, 然后拧紧固定螺丝⑤, 把2个固定螺丝⑤中的第一螺丝对准下轴的平部, 然后拧紧。

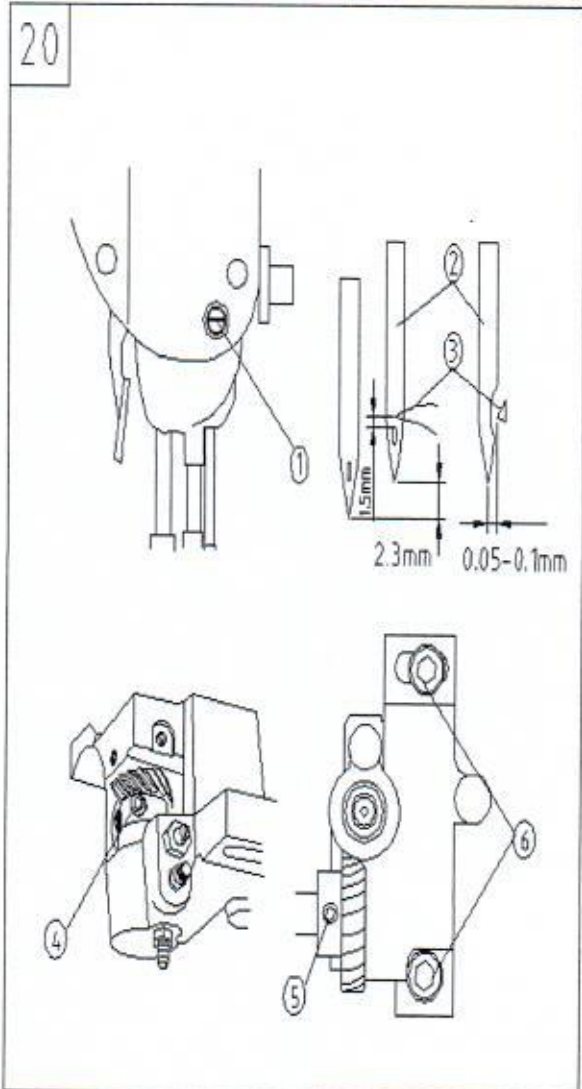

21. Relation of needle and hook (Picture 20)

- 1) Adjust the stitch length adjusting dial to be 0.
- 2) Turn the main wheel, lift up 2.3mm from the lowest position of needle bar. Loose the needle bar connector screw 1, adjust the distance to be 1.5mm between the end of needle 2 hole to the end of hook 3, then tight it

3) Turn the main wheel, lift up 2.3mm from the lowest position of the needle bar. Keep the hook end 3 and the center of needle 2 to be accordance, then tight two screw 4 of the wheel gear (small). To make the first screw in the V shape into the hook shaft also in V shape, and fix it.

4) When the hook end 3 and the center of needle 2 in the accordance position, loose the screw 6 of the hook shaft, move the shaft at left or right side, make the distance to be 0.05-0.1mm, and tight tht screw 6.

5) Loose two screws 5 of the wheel gear (big), move it at lest and right side. Keep the hook end 3 and the center of needle 2 to be accordance, then tight screw 5. Fix the first screw of the two screws 5, and align on the flat part of the bottom shaft, then tight it

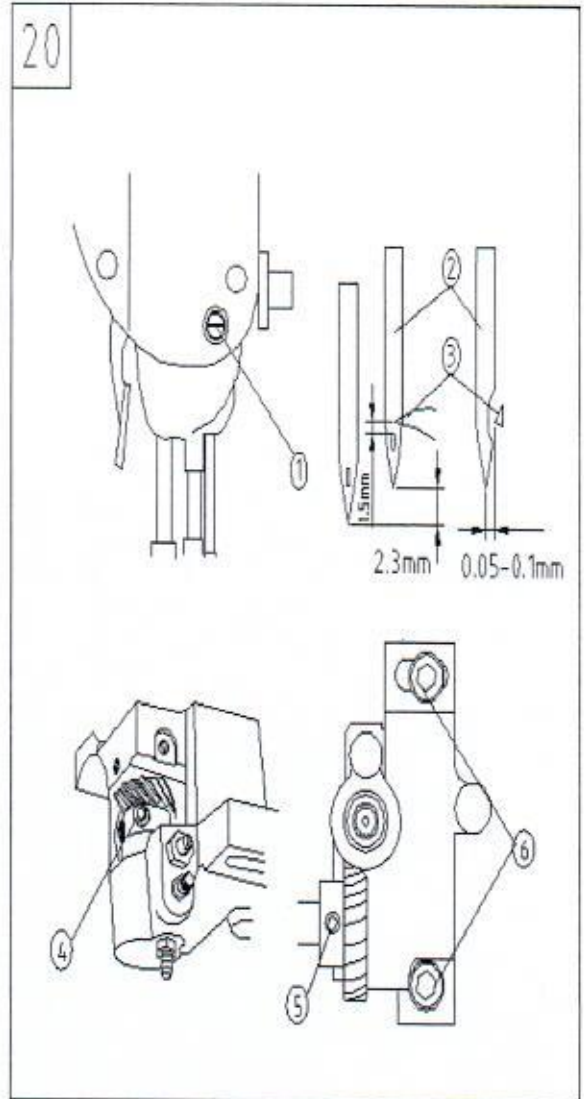

22. 按钮的使用 (见图21)

- ①—倒缝开始; ②—倒缝关闭; ③—DL;
④—补针; ⑤—第二松线; ⑥—中分。

1) 直接分别按①②③④⑤⑥按键, 可实现上述功能;

2) 长按A处①②③④⑤⑥按键下对应的一个按钮, 直致B处灯闪烁, 松手, 则C按钮成为该按键的快捷键。

22. Use of buttons (Picture 21)

1) Key function: ①: Reverse suture; ②: Reverse closing; ③: DL; ④: Fill needle; ⑤: Second loose line; ⑥: Middle separation

2) long press one button at A the ①②③④⑤⑥ button under the corresponding button, until the B lights flashing, let go, C become the key of the shortcut button.

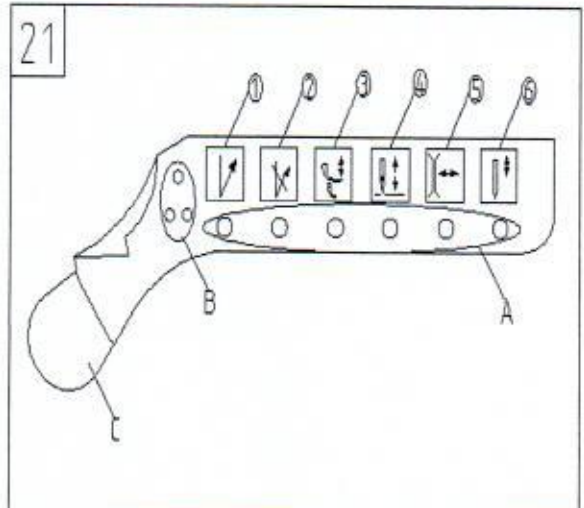

23. 缝制速度一览表

交替上下量	速度
~2mm	2200rpm
2~3mm	2200rpm
3~5mm	2000rpm
5~6.5mm	1600rpm

根据不同条件设定最高转速，请不要超过设定值。

23. Sewing speed schedule

alternation amount	speed
~2mm	2200rpm
2~3mm	2200rpm
3~5mm	2000rpm
5~6.5mm	1600rpm

The highest sewing speed is set in different condition, please do not over the setting.

24. 缝制中出现的问题及处理方法

现象	原因	处理方法
1. 断线 (布背面上线残留 5~mm)	①线道，针尖，旋梭尖，针板的旋梭内圈固定钩有伤痕； ②上线张力过强； ③机针与旋梭尖相碰； ④旋梭部位油量少； ⑤上线张力过弱； ⑥挑线弹簧过强，移送量少； ⑦针与旋梭同步过快或过慢；	用细砂纸打磨旋梭尖的伤痕，用锉刀锉针板的旋梭内圈固定汇率钩。 调节上线张力。 参照(21. 针与旋梭的关系)。 调整油量(参照7. 加油)。 调节上线张力。 减弱挑线弹簧，加大移动量。 参照(21. 针与旋梭的关系)。
2. 跳线	①针与旋梭同步过快或过慢； ②压脚压力过弱； ③针孔上端和旋梭尖的间隙不正确； ④机针号不对；	参照(21. 针与旋梭的关系)。 拧紧压脚调节螺丝 参照(21. 针与旋梭的关系) 更换为大一号的机针。
3. 紧线不良	①梭壳的线张力弹簧下没有穿底线； ②线道加工不好； ③梭芯不滑动； ④底线张力过弱； ⑤底线张力过强； ⑥针尖损伤；	参照(10. 底线的穿线方法)。 用细砂纸打磨或用锉刀锉。 更换梭芯或旋梭。 加强底线张力。 减弱底线绕线张力。 更换机针。

25. Problem and method		
Situation	Reason	Method
1) thread broken (left 2-3mm at the back of material)	1) There is scar from thread way, needle end, hook end and the hook inside circle. 2) Upper thread tension is strong. 3) Needle touch the hook end. 4) Oil amount of hook is small. 5) Upper thread tension is too weak. 6) Taking-up spring is too strong, the movement amount is too small. 7) Needle and hook run at the same time are too fast or too slow.	1) Use the emery paper to deal with scar. Use the files to deal with the inside circle of hook. 2) Make the upper thread weaker. 3) Please check No. 22 the relation between needle and hook 4) Adjust the oil amount (as per No. 7 oiling). 5) Increase the upper thread tension. 6) Make the taking-up spring weaker, enlarge the movement amount. 7) As per No. 22 the relation between needle and hook.
2) thread jumping	1) Needle and hook run at the same time are too fast or too slow. 2) The pressure of presser foot is too weak. 3) The distance between needle hole and hook end is not correct. 4) Needle type is not correct.	1) As per No. 22 the relation between needle and hook. 2) Tight the presser foot adjusting screw. 3) As per No. 22 the relation between needle and hook. 4) Change another large needle.
3) tight thread	1) The tension spring of bobbin case have no threading. 2) Processing of thread way is not good. 3) The bobbin can not slide. 4) Bottom thread is too weak. 5) Bottom thread is too strong. 6) Needle end damage.	1) The tension spring of bobbin case have no threading. 2) Processing of thread way is not good. 3) The bobbin can not slide. 4) Bottom thread is too weak. 5) Bottom thread is too strong. 6) Needle end damage.

零件手册

1. 外部装置 (Frame & miscellaneous cover)

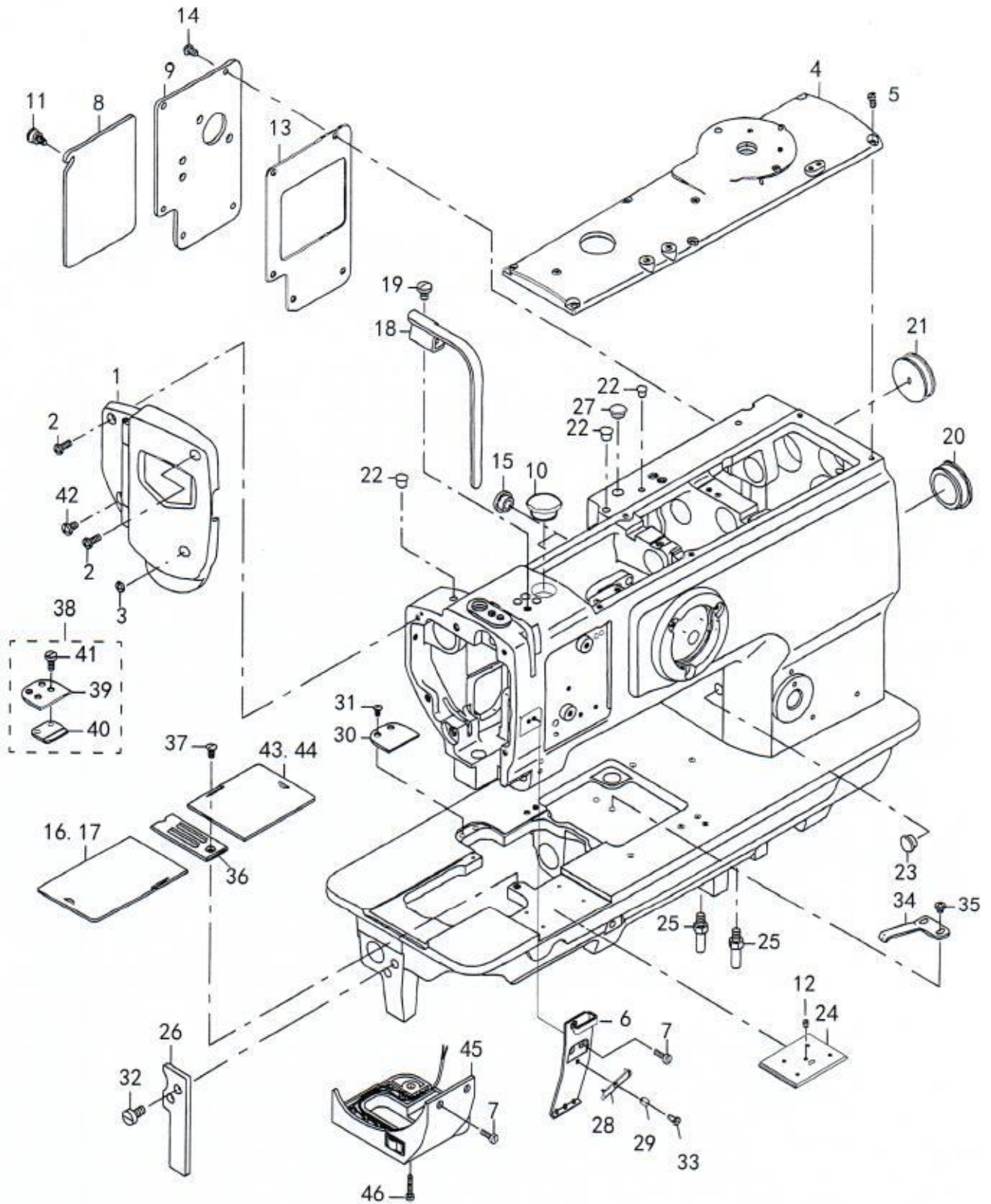

序号	说明	编码及型号	英文名称	中文名称	数量
1		40016798	FACE PLATE ASM.	面板	1
2		SS4111215SP	SCREW 11/64-40 L=12	面板螺钉	2
3		TA1250406RO	LUBRICATION SUPPLEMENT	面板橡皮塞	1
4		21331301	TOP COVER B	上盖板	1
5		SS4110815SP	SCREW 11/64-40 L=8	上盖板螺钉	6
6		020182	THREAD GUIDE PLATE	过线板	1
7		SS05090610SP	SCREW 9/64-40 L=9	过线板螺针	4
8	#01	21331756	WINDOW PLATE A ASM.	小后窗盖组件	1
9		21348909	WIDOW PLATE D	大后窗盖	1
10		020181	RUBBER PLUG	橡皮塞	1
11		21331202	SETSCREW	后盖板螺钉	1
12		LS514	SCREW	螺钉	1
13		21332002	WINDOW PLATE PACKING B	大后窗盖垫	1
14		SS4110815SP	SCREW 11/64-40 L=8	大后窗盖螺钉	5
15		TA1250504RO	RUBBER PLUG	橡皮塞	2
16	#01	21349600	BED SLIDE(LEFT) A	左推板	1
17	#03	020152	BED SLIDE(LEFT) A	左推板	1
18		21331608	BALANCE COVER	防护罩	1
19		SS7150910TP	SCREW 15/64-28 L=9	防护罩螺钉	1
20		22619100	CAP	橡皮塞	1
21		10201200	RUBBER PLUG	橡皮塞	3
22		TA1050504RO	RUBBER PLUG	橡皮塞	1
23		TA1050504RO	RUBBER PLUG	橡皮塞	1
24		020143	Push plate	前推板	1
25		22602601	BED SCREW STUD	底板支撑螺钉	2
26		21361407	BED SUPPORT PLATE	底板支撑板	1
27		TA1050504RO	RUBBER PLUG	橡皮塞	1
28		17912106	NEEDLE THREAD PRESSER PLATE	过线板压板	1
29		B1132521000	THREAD PRESSER PLATE SPRING	过线板压板弹簧	1
30		22651202	AUXILIARY COVER	辅助板	1
31		SS2090710TP	SCREW 9/64-40 L=7.2	辅助板螺钉	2
32		SS6151210SP	SCREW 15/64-28 L=12	底板支撑板螺钉	2
33		SD0380551SL	HINGE SCREW D= 3.80 H= 5.5	过线板螺钉	1
34		B1111563000	BED SLIDE SPRING	右推板托簧	1
35		SS4110515SP	SCREW 11/64-40 L=5	右推板托簧螺钉	2
36	见附表: 针位	attached list	NEEDLE PLATE	针板	1
37		SS2110920TP	SCREW 11/64-40 L=8.5	针板螺钉	2
38	#01	23208556	AUXILIARY COVER ASM.	辅助板组件	1
39	#01	23208507	AUXILIARY COVER	辅助板A	(1)
40	#01	23208606	SLIDING PLATE SUPPORT	辅助板B	(1)
41	#01	SS6111140SP	SCREW 11/64-40 L=11	辅助板组件螺钉	(2)
42		SS4111215SP	SCREW 11/64-40 L=12	面板螺钉	1
43	#03	21349808	BED SLIDE(RIGHT) A	右推板	1
44	#01	21349600	BED SLIDE(RIGHT) A	右推板	1
45		020186	Lighting assembly	照明组件	1
46		SS6091022TP	SCREW	针杆架限位板螺钉	2

#01 1580A用 #03 1580A-7用

2. 挑线及上轴部件(Pick up and upper shaft components)

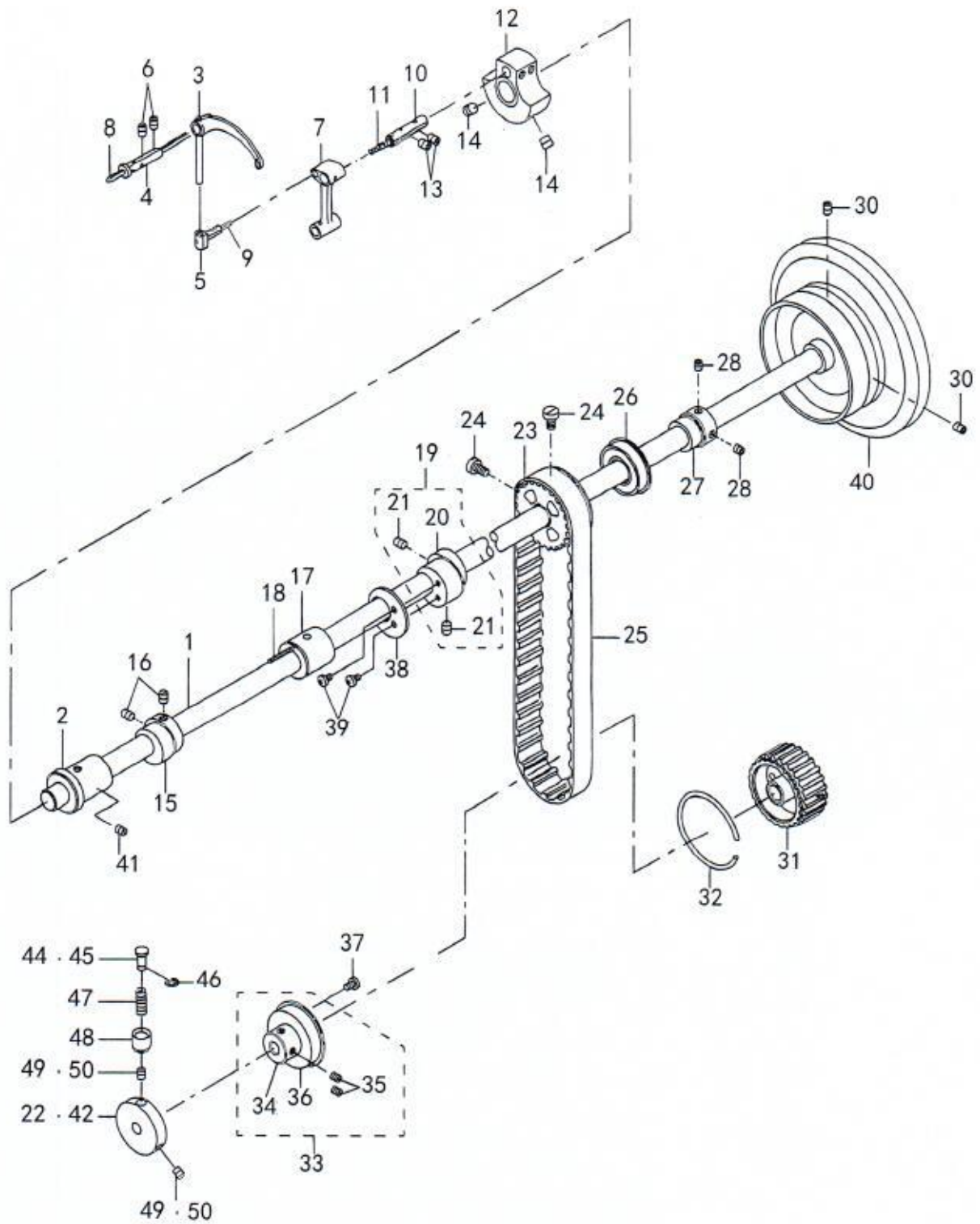

序号	说明	编码及型号	英文名称	中文名称	数量
1		020267	UPPER SHAFT	上轴	1
2		21333000	UPPER SHAFT FRONT METAL	上轴左轴套	1
3		B1905520000	THREAD TAKE-UP LEVER	挑线杆	1
4		B1906051000	TAKE-UP LEVER PIN	挑线杆销	1
5		B1907057000	THRUST PIN	挑线杆滑块	1
6		SS8150822TP	SCREW 15/64-28 L=8	挑线杆销螺钉	1
7		21339106	NEEDLE BAR CRANK ROD	针杆曲柄连杆	1
8		CQ202000000	OIL WICK	油线	0.45
9		CQ202000000	OIL WICK	油线	0.03
10		B1210051000	NEEDLE BAR CRANK PIN	针杆曲柄销	1
11		CQ202000000	OIL WICK	油线	1
12		21332606	COUNTER WEIGHT (A) (38MM)	针杆曲柄	1
13		SS8150822TP	SCREW 15/64-28 L=8	针杆曲柄销螺钉	2
14		SM8080812TP	SCREW M8X8	螺钉	2
15		21339502	UPPER FEED CAM (3.5)	上送布偏心轮	1
16		SS8660810TP	SCREW 1/4-40 L=8	偏心轮支紧螺钉	2
17		21333109	UPPER SHAFT INNER METAL	上轴中轴套	1
18		CQ202000000	OIL WICK	油线	0.15
19		21336557	ECCENTRIC CAM A ASM.	下送料偏心轮组件	1
20		21336508	ECCENTRIC CAM A	下送料偏心轮	1
21		SS8660810TP	SCREW 1/4-40 L=8	下送料偏心轮支紧螺钉	2
22	#01	21333703	SAFETY CLUTCH DISC	按钮卡轮	1
23		22604904	UPPER SPROCKET	上轴同步带轮	1
24		SS6661110SP	SCREW 1/4-40 L=11	上轴同步带轮支紧螺钉	2
25		020268	TIMING BELT	同步带	1
26		B1203512000	BUSHING REAR	轴承	1
27		21402300	UPPER SHAFT BEARING HOOK	上轴轴承套	1
28		SM8060602TP	SCREW M6X6	上轴轴承套螺钉	2
29		21387907	ADJUSTING PIN (1.2)	(下轮)偏心销	1
30		SS8150822TP	SCREW 15/64-28 L=8	皮带轮螺钉	2
31		21387501	LOWER SPROCKET	下轴同步带轮	1
32		B1214019000	SPROCKET RING	下同步带轮环	1
33		40038700	THRUST COLLAR ASM.	下轴轴承芯棒组件	1
34		40038702	THRUST COLLAR	下轴轴承芯棒	(1)
35		SS8661030SP	SCREW 1/4-40 L=10	下轴轴承芯棒螺钉	(2)
36		SB120000200	BEARING 20X42	轴承	1
37		SS7120760SP	SCREW 3/16-28 L= 7.0	下轴轴承固定螺钉	2
38		21353008	HORIZONTAL FEED CAM COVER	下送料偏心轮压板	1
39		SS7110710SP	SCREW 11/64-40 L=7	下送料偏心轮压板螺钉	2
40		21427000	FLYWHEEL	手轮	1
41		SS8150710TP	SCREW 15/64-28 L=7	按钮卡轮支头螺钉	3
42	#03	21333901	SAFETY CLUTCH DISC	按钮卡轮	1
43		SS8111010TP	SCREW 9/64-40 L=9.5	(下轮)偏心销支头螺钉	1
44	#01	B1312563000A	SAFETY CLUTCH PUSH BUTTON	按钮	1
45	#03	21333802	SAFETY CLUTCH PUSH BUTTON	按钮	1
46		RE0500000K0	E-RING	开口挡圈	1
47		B1639051000	SPRING	按钮簧	1
48		B1313055000	SAFETY CLUTCH KNOB SLEEVE	按钮架	1
49	#01	SS8150710TP	SCREW 15/64-28 L=7	按钮卡轮支头螺钉	3
50	#03	SS8660530TP	SCREW 1/4-40 L= 4.5	按钮卡轮支头螺钉	2

#01 1580A用 #03 1580A-7用

3. 针杆摆动装置 (Needle bar rocking)

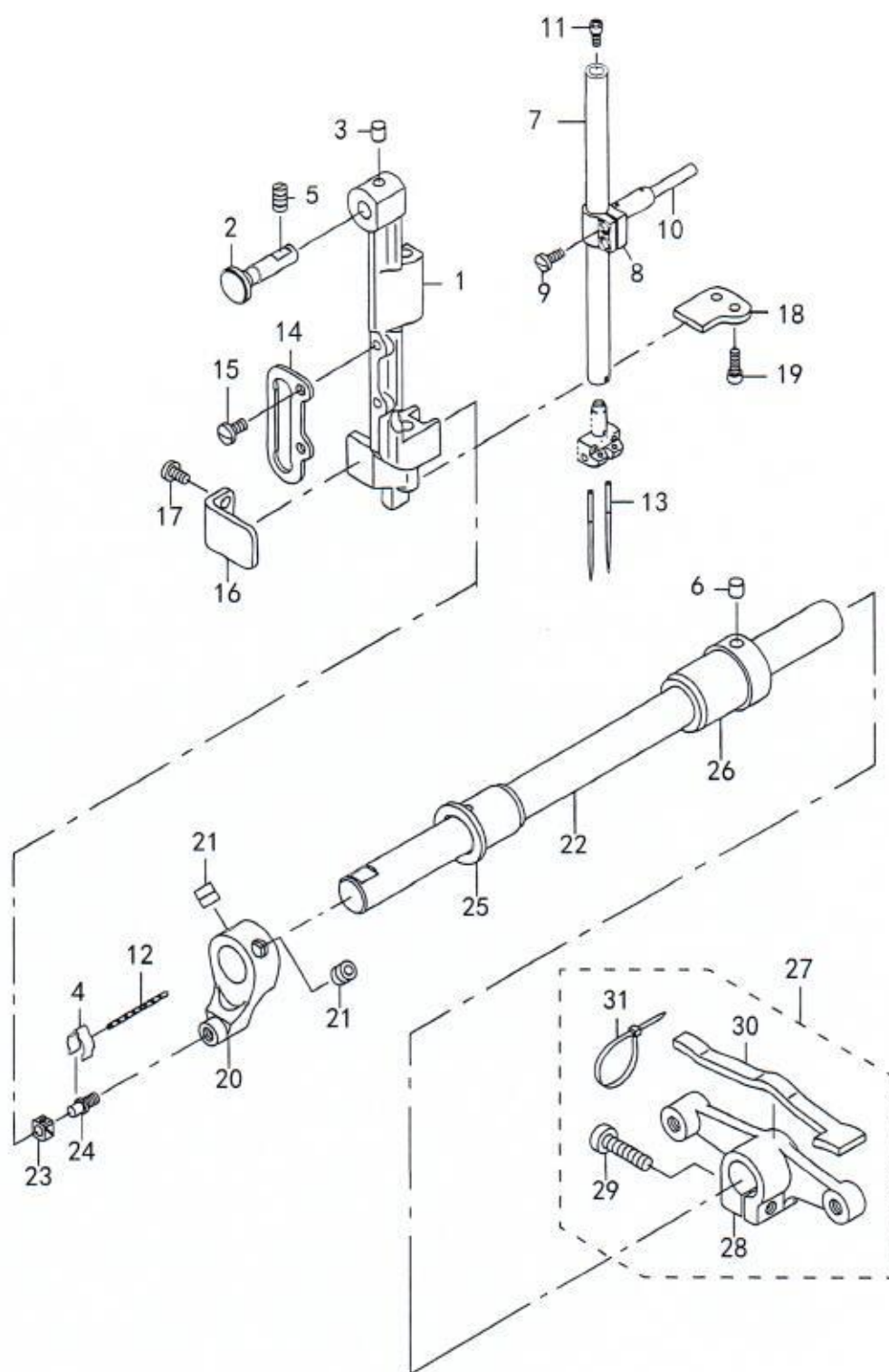

序号	说明	编码及型号	英文名称	中文名称	数量
1		23002009	NEEDLE BAR FRAME	针杆架	1
2		21405204	HINGE STUD	针杆架铰链轴	1
3		22814909	FELT	针杆架油毡	1
4		B1437051000	OIL WICK RETAINER	针杆摆动曲柄油线夹簧	1
5		SS8151150TP	SCREW 15/64-28 L=10.5	针杆架销螺钉	1
6		22814909	FELT	油芯	1
7		030339	NEEDLE BAR	针杆	1
8		B1411057000	NEEDLE ROD HOLDER	针杆接头	1
9		SS7090910SP	SCREW 9/64-40 L= 8.5	针杆接头螺钉	1
10		CQ202000000	OIL WICK	油芯	0.04
11		SM6030602TP	SCREW M3X0.5 L=6	螺钉	1
12		CQ202000000	OIL WICK	油芯	0.05
13		MC372001600	NEEDLE SY3355 160	机针 SY3355 160	2
14		41438007	UPPER FEED BAR GUIDE	防震板	1
15		SS7110910TP	SCREW 11/64-40 L= 8.5	防震板螺钉	2
16		21388400	ROCKING BASE GUIDE	角板	1
17		SS7110830SP	SCREW 11/64-40 L= 7.5	角板螺钉	2
18		21338603A	ROCKING BASE GUIDE (B)	针杆架限位板	1
19		SS6091022TP	SCREW	针杆架限位板螺钉	2
20		21338801	ROCKING FRONT ARM	针杆摆动曲柄	1
21		SM8080812TP	SCREW	针杆摆动曲柄螺钉	2
22		21338900	ROCKING SHAFT	针杆摆动轴	1
23		B1414232000	SQUARE BLOCK	针杆摆动滑块	1
24		B1410771000	STUD	针杆摆动滑块锁销	1
25		21339304	ROCKING SHAFT FRONT METAL	针杆摆动轴左轴套	1
26		40027746	BUSHING REAR	针杆摆动轴右轴套	1
27		21339056	ROCKING REAR ARM ASM.	针杆摆动(送布)曲柄组件	1
28		21339007	ROCKING REAR ARM	针杆摆动(送布)曲柄	1
29		SS6152440SP	SCREW 15/64-28 L=23.5	针杆摆动(送布)曲柄螺钉	-1
30		21347406	ROCKING REAR ARM FELT	针杆摆动(送布)曲柄油毡	1
31		EA9500B0000	CABLE BAND	线卡	2

4. 上送料机构 (Pressure adjusting & upper feed mechanism)

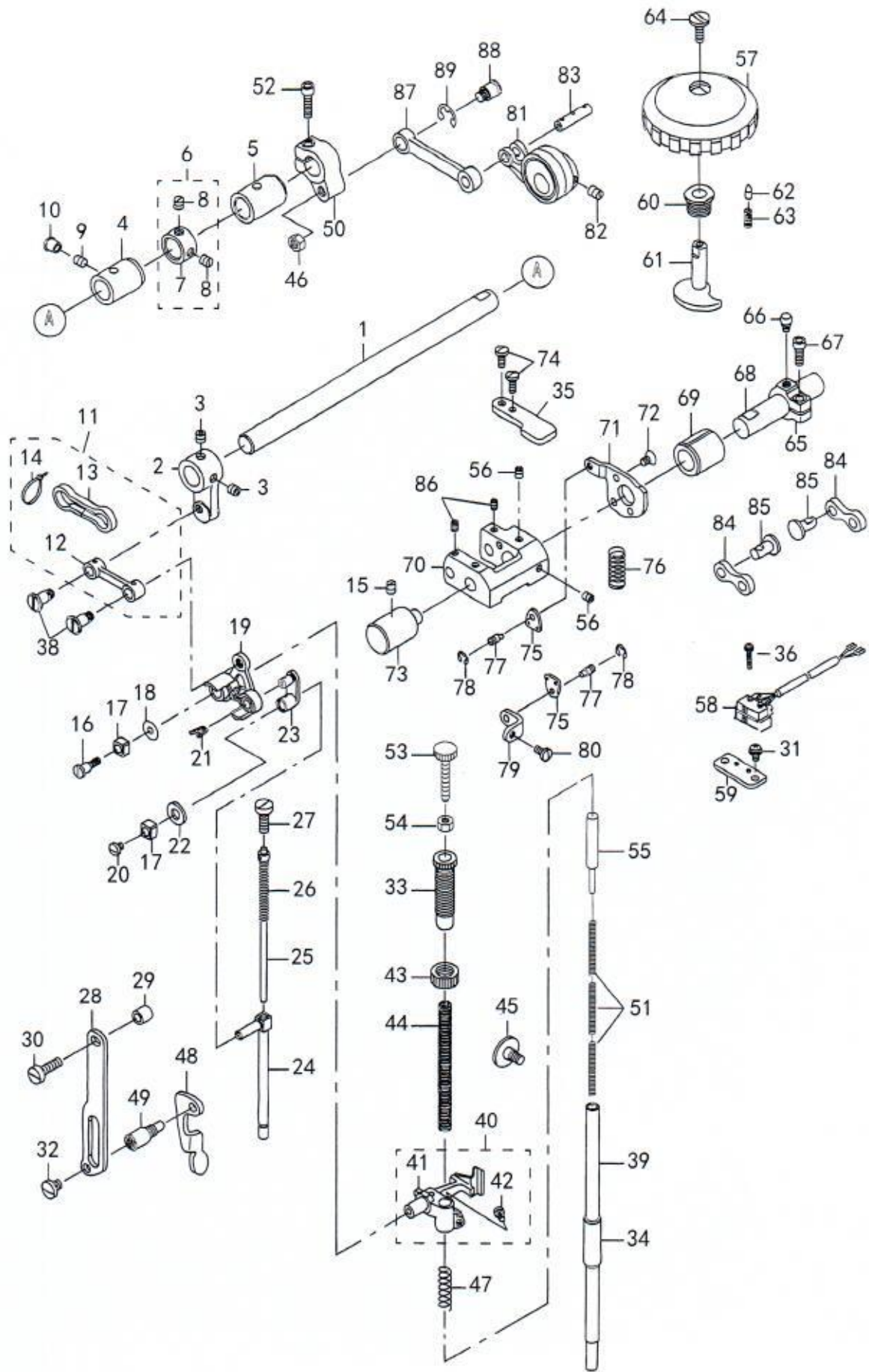

序号	说明	编码及型号	英文名称	中文名称	数量
1		21340401	UPPER FEED SHAFT	上送布轴	1
2		21340500	UPPER FEED FRONT ARM	上送布轴曲柄	1
3		SS8660612TP	SCREW 1/4-40 L=6	上送布轴曲柄支头螺钉	2
4		21341904	FRONT METAL	上送布轴左轴套	1
5		21378302	FEED SHAFT METAL	上送布轴右轴套	1
6		22904155	MAIN SHAFT THRUST COLLAR ASM.	上送布轴紧圈组件	1
7		22904106	MAIN SHAFT THRUST COLLAR	上送布轴紧圈	-1
8		SS8660610TP	SCREW 1/4-40 L=6	上送布轴紧圈螺钉	2
9		SS8150822TP	SCREW 15/64-28 L=7	轴套支紧螺钉	1
10		TA0750704RO	RUBBER PLUG	橡皮塞	1
11		40033027	UPPER FEED LINK ASM.	上送料连杆组件	1
12		40033026	UPPER FEED LINK	上送料连杆	-1
13		21347109	FELT	上送料连杆油毡	-1
14		EA9500B0000	CLIP CV-70S	尼龙自锁夹	-2
15		SS8150710SP	SCREW 15/64-28 L=7	螺钉	1
16		SD0640701SP	SCREW	抬压脚滑块螺钉	1
17		B1414555000	SLIDE BLOCK	抬压脚滑块	2
18		WP0501046SC	WASHER 5 X 13 X 1	抬压脚滑块垫圈	1
19		40033029	TRIANGULAR LEVER ASM.	角形连杆	1
20		SS7110510SP	SCREW 11/64-40 L=5	防震滑块螺钉	1
21		CQ202000000	OIL WICK	抬压脚滑块	0.02
22		10509701	FELT	角形连杆小连接油毡	1
23		B1456053000L	WALKING BAR DRIVING LINK	角形连杆小连接	1
24		40033030	WALKING BAR A	内压紧杆	1
25		B14670530A0	WALKING BAR ASM.	内压脚弹簧杆	1
26		B1468053000	WALKING BAR SPRING	内压脚弹簧	1
27		SS6151780SP	SCREW 15/64-28 L=17.0	内压紧杆螺钉	1
28		21406509	UPPER FEED GUIDE PLATE	抬压脚导轨	1
29		26225201	ROLLER	抬压脚导轨垫圈	
30		SS6151920SP	SCREW 15/64-28 L=19.0	抬压脚导轨螺钉(上)	1
31	#03	SM6040800SP	SCREW M4 L=8	开关座螺钉	2
32		SS7150740SP	SCREW 15/64-28 L=7	螺钉	1
33		21006408	ADJUST SCREW A	调压大螺杆	1
34		B1510155000	PRESSER BAR LOWER BUSHING	压紧杆轴套	1
35		21339700	UPPER FEED STOPPER PLATE	挡板	1
36	#03	020497	SCREW M2.5*16	螺钉	2
37	#01 #03	SS4110815SP	SCREW 1/4-40 L=8	螺钉	2
38		40018340	SCREW	螺钉	2
39		030292	PRESSER BAR	压紧杆	1
40		40039265	PRESSER BAR HOLDER A ASM.	压紧杆夹头组件	1
41		40039266	PRESSER BAR HOLDER A	压紧杆夹头	1
42		SS7110910TP	SCREW 11/64-40 L= 8.5	压紧杆夹头螺钉	1
43		22907604	PRESSER SPRING REGULATOR NUT	调压螺帽	1
44		B1502246000	PRESSER SPRING	调压簧	1
45		SD0800481SP	HINGE SCREW D= 8 H= 4.9	压紧杆夹头限位螺钉	1
46		NS6680320SP	NUT 9/32-28	螺母	1
47		B1462053000	THREAD RELEASE SPRING	压紧杆夹头弹簧	1
48		21406103	PRESSER LIFTER LEVER	压脚扳手	1
49		21406608	GUIDE PLATE SPACER	压脚扳手螺钉	1
50		21340302	UPPER FEED REAR ARM (B)	压脚交替提升曲柄	1

#01 1580A用 #03 1580A-7用

4. 上送料机构 (Pressure adjusting & upper feed mechanism)

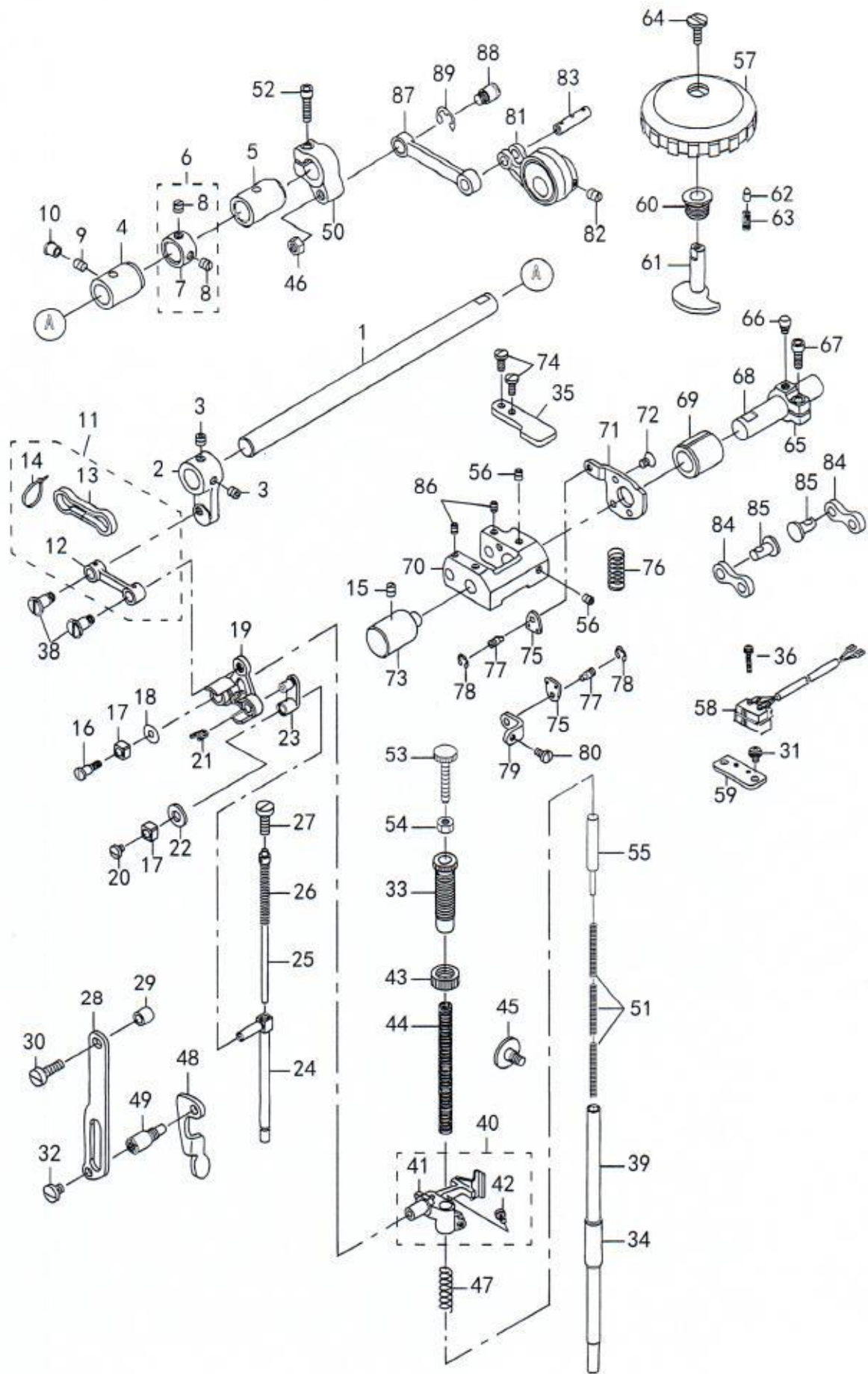

序号	说明	零件号	英文名称	中文名称	数量
51		21006002	ADJUST SPRING B	弹簧	3
52		SM6052002TP	SCREW M5 L=20	压脚交替提升曲柄并紧螺钉	1
53		21006507	ADJUST SCREW B	调压小螺杆	1
54		NS6110530SP	NUT 11/64-40	螺母11/64-40	1
55		40072709	SPRING SUPPORT SHAFT ASM.	调压导杆	1
56		SM8050602TP	SCREW M5 L=6	螺钉	2
57		10774354	UPPER AND LOWER DIAL ASM.	压脚胶替提升调节盘组件	(1)
58	#03	40024852	VERTICAL DETECTOR SWITCH ASM.	限速开关组件(900MM)	1
59	#03	020494	VERTICAL DETECTOR SWITCH ASM.	开关座	1
60		10715100	VERTICAL DIAL SHAFT BUSHING	压脚调节凸轮轴套	1
61		10715001	VERTICAL ADJUSTING CAM	压脚交替提升调节凸轮	1
62		10715704	VERTICAL DIAL PIN	压脚交替提升调节盘止动销	1
63		B152652700G	SPRING	压脚交替提升调节盘止动弹簧	1
64		SS6110630TP	SCREW 11/64-40 L=6	压脚交替提升调节凸轮螺钉	1
65		21341607	VERTICAL ADJUSTING ARM	压脚交替提升调节曲柄	1
66		10715308	PIN	压脚交替提升调节曲柄销	1
67		SM6051402TP	SCREW M5X0.8 L=14	压脚交替提升调节曲柄螺钉	1
68		21341508	VERTICAL CHANGE BASE SHAFT	压脚交替提升轴	1
69		10718203	FEED SHAFT FRONT METAL	压脚交替提升轴套	1
70		10714202	VERTICAL CHANGE BELT	压脚交替提升变动曲柄	1
71		21438106	STOPPER PLATE B	支架板	1
72		SM1050801SR	SCREW M5 L=8	上送料弹簧支架螺钉	1
73		21337803	FEED ADJUSTING BASE SUPPORT	变动曲柄轴	1
74		SS4110815SP	SCREW	挡板螺钉	2
75		10713501	SPRING HOOK	曲柄拉簧支板	2
76		10716504	VERTICAL SHAFT SPRING	曲柄拉簧	1
77		B3416552000	CONNECTING ROD HINGE SCREW	簧板连接铰接螺栓	2
78		RE0500000K0	E-RING	开口挡圈	2
79		21339809	UPPER FEED DOG SPRING HOOK	上送料限位簧板	1
80		SS7110830SP	SCREW 11/64-40 L= 7.5	上送料限位簧板螺钉	1
81		10713766	ECCENTRIC ROD (SET)	压脚交替提升大连杆	1
82		SS8660810TP	SCREW 1/4-40 L=8	偏心轮螺钉	2
83		10713808	CONNECTION LINK PIN B	压脚交替提长连杆销	1
84		10714509	CONNECTION LINK B	曲柄短连杆	2
85		10714608	CONNECTION LINK B SUPPORT PIN	曲柄短连杆销	2
86		SM8050602TP	SCREW M5 L=6	螺钉	2
87		21340005	UPPER FEED LINK (B)	压脚交替提升曲柄连杆	1
88		21048707A	HINGE SCREW	压脚交替提升曲柄连杆螺钉	1
89		RE0800000K0	E-SHAPED SNAP RING (8MM)	压脚交替提升曲柄连杆挡圈	1

#01 1580A用

#03 1580A-7用

5. 送料机构 (Feed mechanism)

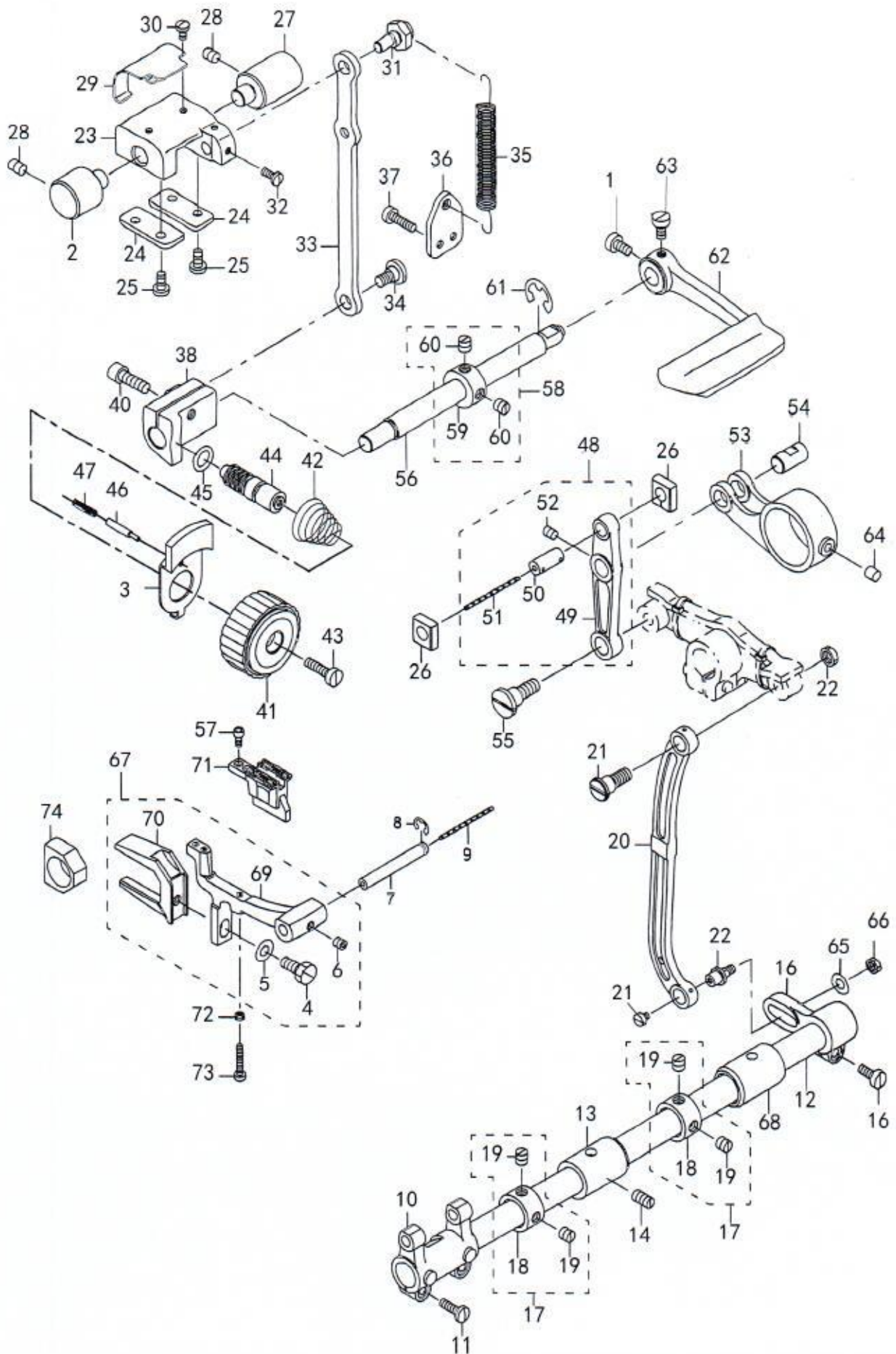

序号	说明	编码及型号	英文名称	中文名称	数量
1		SS7150910TP	SCREW 15/64-28 L=9	螺钉15/64-28 L=9	1
2		21430400	FEED ADJUSTING BASE SUPPORT	送料调节座支架(短)	1
3		010561	BOTTON	离合按钮	1
4		SS9151440CP	SCREW 15/64-28 L=14	抬牙叉螺钉	(1)
5		WP0621016SD	WASHER 6. 2X13X1	抬牙叉垫圈	(1)
6		SM8050502TP	SCREW M5 L=5	牙架螺钉	(1)
7		B1604012000A	FEED BAR SHAFT	牙架曲柄螺钉	1
8		RE0500711KP	SNAP RING 5	挡圈	1
9		CQ202000000	OIL WICK	油芯	0.14
10		21364104	FEED ROCKER	牙架曲柄	1
11		SS7111410SP	SCREW 11/64-40 L=14	牙架曲柄螺钉	2
12		020573	FEED ROCK SHAFT	送布轴	1
13		21378302	FEED SHAFT METAL	送布轴左、右轴套	1
14		020514	SCREW 11/64-40 L=8.5	螺钉	2
15		22609309L	FEED ROCKER SHAFT CRANK	可调送布摇臂曲柄	1
16		SS6121610TP	SCREW 3/16-28 L=15.5	送布右曲柄螺钉	1
17		22904155	MAIN SHAFT THRUST COLLAR ASM.	紧圈组件	2
18		22904106	MAIN SHAFT THRUST COLLAR	紧圈	(1)
19		SS8660610TP	SCREW 1/4-40 L=6	紧圈螺钉	(2)
20		020574	NEEDLE BAR FRAME ROD	送布长连杆	1
21		SS6110630TP	SCREW 11/64-40 L=6	螺丝	1
22		21378203	FEED ROCK SHAFT HINGE SCREW	送步驱动曲柄连杆铰链螺钉	1
23		21337506	FEED ADJUSTING BASE	针距调节曲柄	1
24		21337704	FEED ADJUSTING BASE COVER	针距调节滑块压板	2
25		SS7110910TP	SCREW 11/64-40 L= 8.5	针距调节滑块压板螺钉	4
26		21337407	SQUARE BLOCK	针距调节曲柄滑块	2
27		21337803	FEED ADJUSTING BASE SUPPORT	针距调节曲柄轴	2
28		SS8150822TP	SCREW 15/64-28 L=8	支紧螺钉	2
29		21338306	FELT SUPPORT	针距调节曲柄油毡压板	1
30		SS5090610SP	SCREW 9/64-40 L=6	针距调节曲柄油毡压板螺钉	2
31		21337902	ECCENTRIC PIN	针距调节偏心销轴	1
32		SS709010TP	SCREW 9/64-40 L= 8.5	针距调节偏心销轴支头螺钉	2
33		21337308	FEED ADJUSTING ROD	针距调节连杆	1
34		SD0800402TP	HINGE SCREW D= 8 H= 4	针距调节连杆螺钉	1
35		21337605	SPRING	针距调节曲柄拉簧	1
36		21338009	SPRING HOOK	针距调节曲柄拉簧架	1
37		SS7111410TP	SCREW 11/64-40 L=16	针距调节曲柄拉簧架螺钉	2
38		21337209	FEED ADJUSTING A	针距摆杆	1
39		B1610512000	FEED DRIVING SLIDE BLOCK	送布凸轮滑块	1
40		SM6061802TP	SCREW M6 L=18	送布凸轮滑块螺钉	1
41		010536A	FEED DIAL A	针距标盘	1
42		010562	SPRING	弹簧	1
43		SS6121860SP	SCREW 3/16-28 L=18	针距标盘螺钉	1
44		11009909	FEED REGULATOR SCREW	针距调节螺栓	1
45		R0092270200	RUBBER RING	针距调节螺栓O形圈	1
46		010563	FEED REGULATOR PIN	止动销	1
47		22912109	FEED REGULATOR PIN SPRING	止动销弹簧	1
48		21336656	FEED LINK ASM.	针杆摆动连杆组件	1
49		21336607	FEED LINK	针杆摆动连杆(三眼)	(1)
50		B1418761000	CONNECTING FORKED LINK PIN	滑块轴	1

5. 送料机构 (Feed mechanism)

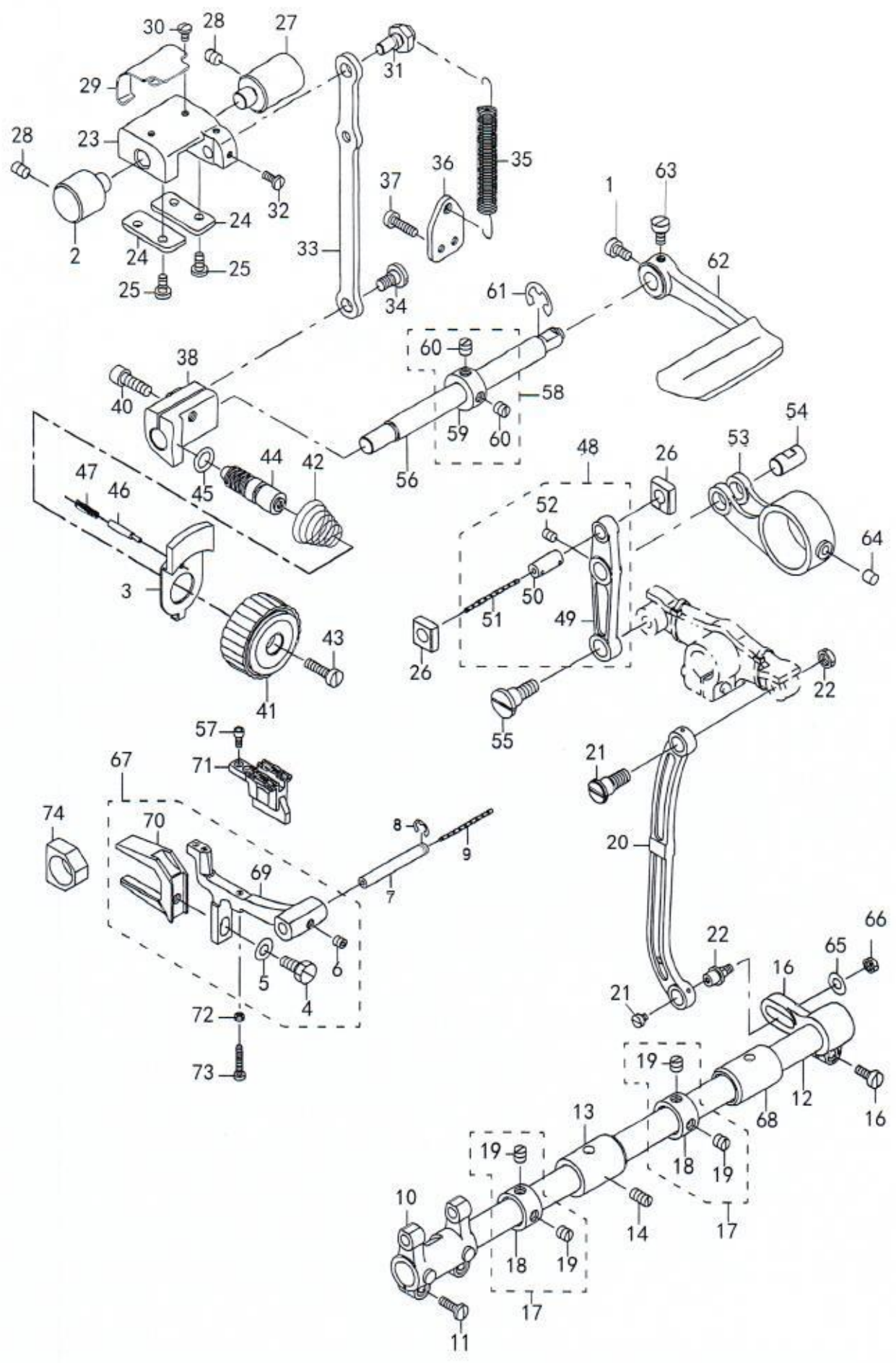

序号	说明	编码及型号	英文名称	中文名称	数量
51		CQ202000000	OIL WICK	滑块轴油芯	0.04
52		SM8050502TP	SCREW M5X6	送布大连杆销轴支头螺钉	1
53		21336706	FEED ROD A	送料连杆	1
54		21338207	FEED LINK PIN	送布大连杆销轴	1
55		SD1000801SH	HINGE SCREW D=10 H=8	针杆摆动连杆连接螺钉	1
56		21336300	BACKWARD FEED LEVER SHAFT	倒缝扳手轴	1
57		SS6580752TP	SCREW 1/8-40 L=7	送布牙螺钉	2
58		CS1201010SH	THRUST COLLAR ASM. D=12 W=10	倒缝扳手轴紧圈组件	1
59		CS1201011SH	THRUST COLLAR D=12 W=10	倒缝扳手轴紧圈	(1)
60		SS8660610TP	SCREW 1/4-40 L=6	紧圈螺钉	(2)
61		RE0900000K0	E-RING 9	倒缝扳手轴用开口挡圈	1
62		21388004	REVERSE FEED CONTROL LEVER	倒缝扳手	1
63		SS6120930TP	SCREW 3/16-28 L=9	倒缝扳手螺钉	2
64		22814909	FELT	送料连杆油毡	1
65		WP0650876SD	WASHER 6.5X13X0.8	垫圈	1
66		NS6150310SP	NUT 15/64-28	螺帽15/64-28	1
67		21364252	FEED BASE ASM.	牙架组件	1
68		020568	FEED SHAFT METAL	送布轴右轴套	1
69		21364203	FEED BASE	牙架	1
70		10107902	FEED BAR FORK	抬牙叉	1
71	见附表: 针位 (attached list)		FEED DOG	送布牙	1
72		NS6080210SP	NUT 1/8-44	送布右曲柄螺母	1
73		SS6081810SP	SCREW 1/8-44 L=18.0	送布牙辅助螺钉	1
74		B1610512000	FEED DRIVING SLIDE BLOCK	送布凸轮滑块	1

6. 旋梭、下轴机构(Hook shaft & upper feed mechanism)

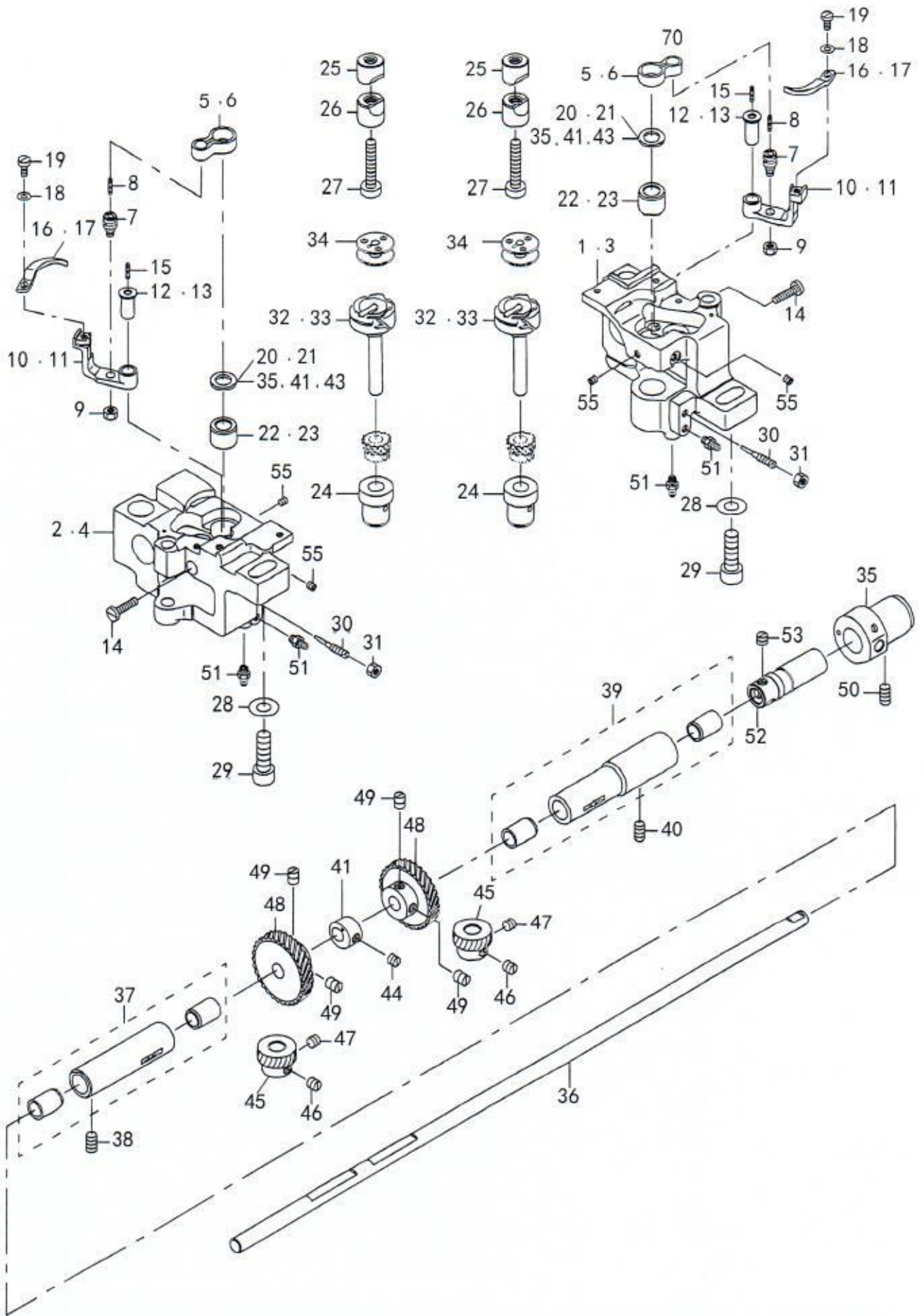

序号	说明	编码及型号	英文名称	中文名称	数量
1	#03	21390000	HOOK SHAFT BASE (RIGHT)	右旋梭架	1
2	#03	21390109	HOOK SHAFT BASE (LEFT)	左旋梭架	1
3	#01	21335104	HOOK SHAFT BASE (RIGHT)	右旋梭架	1
4	#01	21362108	HOOK SHAFT BASE (LEFT)	左旋梭架	1
5	#03	21334909	INNER HOOK GUIDE LINK	分线勾连杆	2
6	#01	21334909	BOBBIN CASE OPENING LEVER LINK	分线勾连杆	1
7		B1821051000	CRANK SCREW STUD	分线座滚柱螺钉	2
8		CQ202000000	OIL WICK	分线座滚柱螺钉油芯	0.02
9		NS6110420SP	NUT 11/64-40	分线座滚柱螺母	2
10	#03	21335500	GUIDE ARM (FOR THREAD CUTTING)	分线勾座	2
11	#01	B1822563000	BOBBIN CASE OPENING LEVER CRAN	分线勾座	2
12	#03	21335708	INNER HOOK GUIDE ARM SHAFT	分线勾连杆销	2
13	#01	B1823051000	OPENING LEVER CRANK PIN	分线勾连杆销	2
14		SS7111810TP	SCREW 11/64-40 L=18	分线座铰链轴支紧螺钉	2
15		CQ202000000	OIL WICK	分线勾连杆销油芯	0.02
16	#03	21335807	INNER HOOK GUIDE	分线勾	2
17	#01	B1824563000	BOBBIN CASE OPENING LEVER	分线勾	2
18		WP0371016SD	WASHER 3.7X8X1	分线勾垫片	2
19		SS6090810SP	SCREW 9/64-40 L= 7.5	分线勾螺钉	2
20		10111102	THRUST WASHER 0.9	旋梭架上套垫圈	2
21		10112704	THRUST WASHER 1.2	旋梭架上套垫圈	2
22	#03	21378401	HOOK SHAFT UPPER METAL	旋梭架上套	2
23	#01	21378500	HOOK SHAFT UPPER METAL	旋梭架上套	2
24		21334701	HOOK SHAFT LOWER METAL	旋梭架下套	2
25		10109908	SADDLE INSTALLING BLOCK UPPER	旋梭架紧固套2	2
26		10112407	SADDLE INSTALLING BLOCK LOWER	旋梭架紧固套1	2
27		SS6153040SP	SCREW 15/64-28 L=30	旋梭架紧固套螺钉	2
28		WP0850002SP	WASHER 8.5X18X1.6	梭架固定垫片	2
29		SM6082502TP	SCREW M8 L=25	梭架固定螺钉	2
30		B1834512000A	OIL ADJUSTING SCREW	油量调节螺钉	2
31		NS6110420SP	NUT 11/64-40	公线座滚线螺母	2
32	#03	SC1510NI1	THREAD TRIMMER HOOK ASM.	旋梭	2
33	#01	SC1510N7I	VERTICAL-AXIS SEWING HOOK ASM.	旋梭	2
34		21334800	ALUMINUM BOBBIN WITH KNURL	梭芯	2
35		10112506	THRUST WASHER 0.6	旋梭架上套垫圈	2
36		220671	LOWER SHAFT	下轴	1
37		B18025120AOA	BUSHING ASM. FRONT	梭架左套组件	1
38		SS8151150TP	SCREW 15/64-28 L=10.5	支头螺钉	1
39		B18035150AO	BUSHING ASM. INTERMEDIATE	梭架右套组件	1
40		SS8151150TP	SCREW 15/64-28 L=10.5	去头螺钉	1
41		10111003	THRUST WASHER 1.1	旋梭架上套垫圈	2
42	#01	22609804	FEED DRIVING CAM	抬牙凸轮	1
43		10109700	THRUST WASHER 1.5	旋梭架上套垫圈	2
44	#01	SS8660530TP	SCREW 1/4-40 L= 4.5	抬牙凸轮螺钉	1
45		B1817051000	HOOK DRIVING SHAFT GEAR SMALL	螺旋小齿轮	2
46		SS8660670SP	SCREW 1/4-40 L= 6.1	旋梭齿轮定位螺钉	2
47		SS8660530TP	SCREW 1/4-40 L= 4.5	抬牙凸轮螺钉	2
48		B1816051000	HOOK DRIVING SHAFT GEAR LARGE	螺旋大齿轮	2
49		SS8660810TP	SCREW 1/4-40 L=8	螺旋大齿轮螺钉	4
50		SS8151150SP	SCREW 15/64-28 L=10.5	支头螺钉	1
51		SQ1110401MZ	CONNECTING SCREW	油管连接小螺钉	4
52		22611909	OIL PUMP SHAFT	油泵轴	1
53		SS8660530TP	SCREW 1/4-40 L= 4.5	抬牙凸轮螺钉	3
54		22611701	PLUNGER BUSHING B	下轴右套	1
55		SS8110422TP	SCREW 11/64-40 L=4	旋梭轴套支头螺钉	4

#01 1580A用 #03 1580-7用

7. 切线部分 (Thread cutting components)

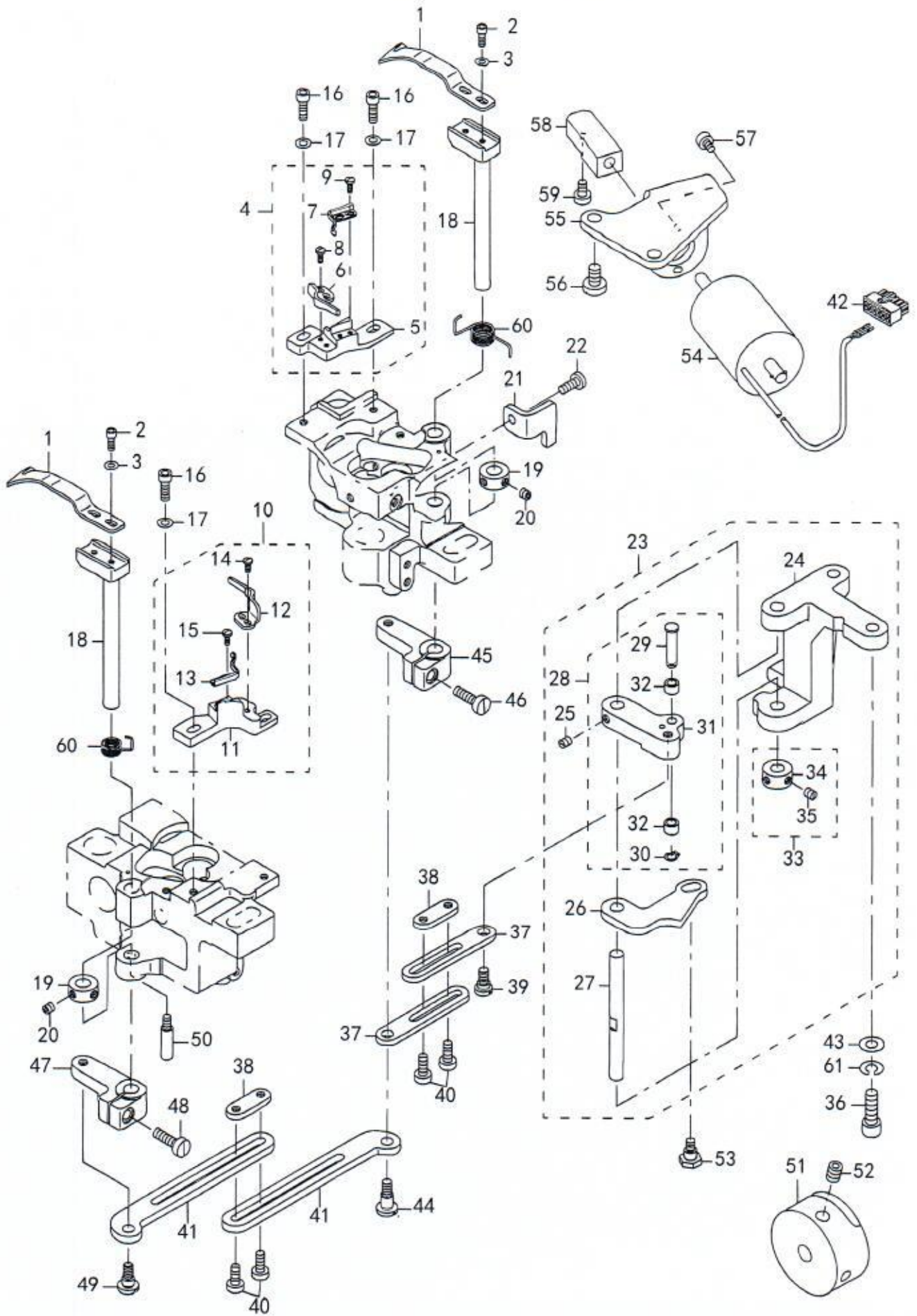

序号	说明	编码及型号	英文名称	中文名称	数量
1		21389200	MOVING KNIFE	动刀	2
2		SM6030802TP	SCREW M3X0.5 L=8	动刀螺钉	4
3		10748101	WASHER M3	垫圈	4
4		21389556	FIXED KNIFE BASE (RIGHT) ASM.	定刀安装座组件(右)	1
5		21389507	FIXED KNIFE BASE (RIGHT)	定刀架安装座(右)	1
6		21389309	FIXED KNIFE	定刀	1
7		21389408	CLAMP SPRING	支架簧	1
8		SS7060610SP	SCREW 3/32-56 L= 5.5	定刀螺钉	2
9		SS7060610SP	SCREW 3/32-56 L= 5.5	支架簧螺钉	2
10		21389655	FIXED KNIFE BASE (LEFT) ASM.	定刀安装座组件(左)	1
11		21389606	FIXED KNIFE BASE (LEFT)	定刀架安装座(左)	1
12		21389309	FIXED KNIFE	定刀	1
13		21389408	CLAMP SPRING	支架簧	1
14		SS7060610SP	SCREW 3/32-56 L= 5.5	定刀螺钉	2
15		SS7060610SP	SCREW 3/32-56 L= 5.5	支架簧螺钉	2
16		SM6041202TP	SCREW M4X0.7 L=12	定刀架安装座螺钉	4
17		WPO430800SC	WASHER M4	定刀架安装座螺钉垫圈	4
18		21354907	MOVING KNIFE SHAFT	活动刀架	2
19		CS0790731SH	THRUST COLLAR	活动刀架推力紧圈	2
20		SS8110422TP	SCREW 11/64-40 L=4	活动刀架推力紧圈螺钉	4
21		21354501	THREAD CUTTING STOPPER (RIGHT)	动力限位板(右)	1
22		SS7111120SP	SCREW 11/64-40 L=10.5	动力限位板(右)螺钉	1
23		21353750	VERTICAL FITTING BASIS ASM.	剪刀驱动曲柄座组件	1
24		21353701	VERTICAL FITTING BASIS	剪刀驱动曲柄座	1
25		SS8110510SP	SCREW 11/64-40 L=5	剪刀驱动曲柄螺钉	2
26		21354006	THREAD CUTTING DRIVING PLATE	剪线驱动连杆	1
27		10116804	SHAFT	剪线支架轴	1
28		21353859	THREAD CUTTING ROLLER ARM	剪刀驱动曲柄组件	1
29		21353909	CAM ROLLER SHAFT	剪线凸轮滚子销钉	1
30		D2430555B00	SNAP RING	剪线凸轮滚子销钉挡圈	1
31		21353800	THREAD CUTTING ROLLER ARM	剪线驱动曲柄	1
32		D2427555B00B	CAM ROLLER	剪线凸轮滚子	2
33		CS070081BSH	THRUST COLLAR ASM. D=7 W=8	剪线支架轴轴套组件	1
34		CS0700811SH	THRUST COLLAR D=7 W=8	剪线支架轴轴套	1
35		SS8110510SP	SCREW 11/64-40 L=5	剪线支架轴轴套螺钉	2
36		SS6151812TP	SCREW 15/64-28 L=18	剪线驱动曲柄座螺钉	2
37		21354105	CONNECTING PLATE	剪线调节短连杆	2
38		21354204	STOPPING PLATE	剪线调节连杆锁紧板	2
39		SD0640325SP	HINGE SCREW	剪线调节短连杆连接螺钉	1
40		SS6111140SP	SCREW 11/64-40 L=11	剪线调节连杆锁紧板螺钉	4
41		21363601	CONNECTING PLATE	剪线调节连杆	2
42		HK034610120	HOUSING 12P	剪线电磁铁接线柱套	1
43		WPO621016SD	WASHER 6.2X13X1	定刀架安装座(右)螺钉	2
44		SD0640751SP	HINGE SCREW D= 6.35 H= 7.5	剪线调节连杆连接螺钉	1
45		21389705	ROCKING ARM (RIGHT)	活动刀架传动曲柄(右)	1
46		SS6121610TP	SCREW 3/16-28 L=15.5	传动曲柄夹紧螺钉	1
47		21389804	ROCKING ARM (LEFT)	活动刀架传动曲柄(左)	1
48		SS6121610TP	SCREW 3/16-28 L=15.5	传动曲柄夹紧螺钉	1
49		SD0640451TP	HINGE SCREW D=6.35 H=4.5	剪线调节连杆螺钉	1
50		B1515512000	HAND LIFTER SHAFT	动刀限位柱(左)	1
51		21389911	THREAD TRIMMER CAM	切线凸轮	1
52		SS8660612TP	SCREW 1/4-40 L=6	切线凸轮螺钉	2
53		SD0640482SP	HINGE SCREW D= 6.35 H= 4.8	剪线驱动连杆螺钉	1
54		21355102	THREAD CUTTING SOLENOID	剪线电磁铁	1
55		21354600	SOLENOID FITTING PLATE	剪线电磁铁座	1
56		SS6151040SP	SCREW 15/64-28 L=10	剪线电磁铁座螺钉	2
57		SM6040802TP	SCREW M4X0.7 L=8	剪线电磁铁螺钉	2
58		21354709	SOLENOID CONNECTING PLATE	剪线驱动连杆连接块	1
59		SS6110710TP	SCREW 11/64-40 L= 6.5	螺钉	2
60		21390208	MAINTENANCE SPRING	扭簧	2
61		THQ6	SPRING WASHER	弹垫	2

8. 夹线机构 (Thread tension components)

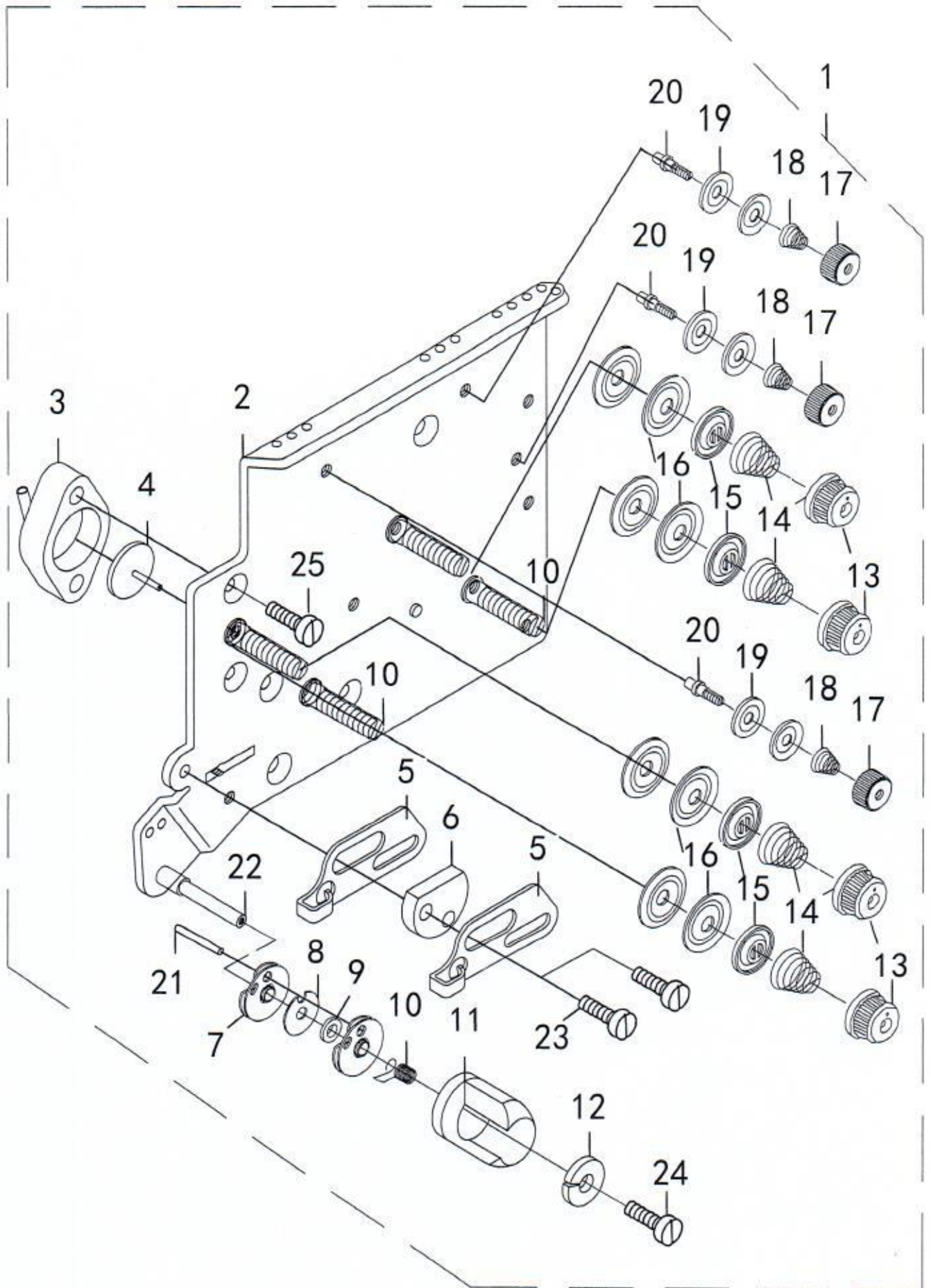

序号	说明	图号	编码及型号	英文名称	中文名称	数量
1		020840	020840	THREAD TENSION ASM.	夹线器组件	1
2		020841A	020841A	THREED POST BASE COMPL.	底板	1
3		020841B	020841B	Cylinder block	气缸体	4
4		020841C	020841C	Cylinder thimble	气缸顶	4
5		020841D	020841D	Passing plate	过线件	2
6		020841E	020841E	Fixed block	过线件固定块	1
7		020841F	020841F	TAKE-UP SPRING GUIDE DISC ASM	挑线簧过线盘组件	2
8		020841G	020841G	PAD	垫	1
9		020841H	020841H	PAD	小垫	1
10		020841I	020841I	Torsion spring	扭簧	2
11		020841J	020841J	Torsion spring bracket	扭簧托	1
12		020841K	020841K	PAD	平垫	1
13		020841L	020841L	THREAD TENSION NUT	过线调节螺母	4
14		020841M	020841M	TENSION SPRING NO. 1	过线夹线簧	4
15		020841N	020841N	BOBBIN WINDER TENSION DISC	夹线板压板	4
16		020841O	020841O	BOBBIN WINDER TENSION DISC	过线夹线板	8
17		020841P	020841P	TENSION NUT	夹线调节螺母	3
18		020841Q	020841Q	TENSION SPRING	夹线簧	3
19		020841R	020841R	TENSION DISC	夹线板	3
20		020841S	020841S	THREAD TENSION POST B	长过线桩	3
21		020841T	020841T	PIN	销	1
22		020841U	020841U	AXIS	挑线小轴	1
23		LS4C10	LS4C10	SCREW STUD	螺钉	2
24		LS4C8	LS4C8	SCREW STUD	螺钉	1
25		LS4N6	LS4N6	SCREW STUD	内六角花形螺钉	8

9. 绕线装置(Lower thread winder mechanism component)

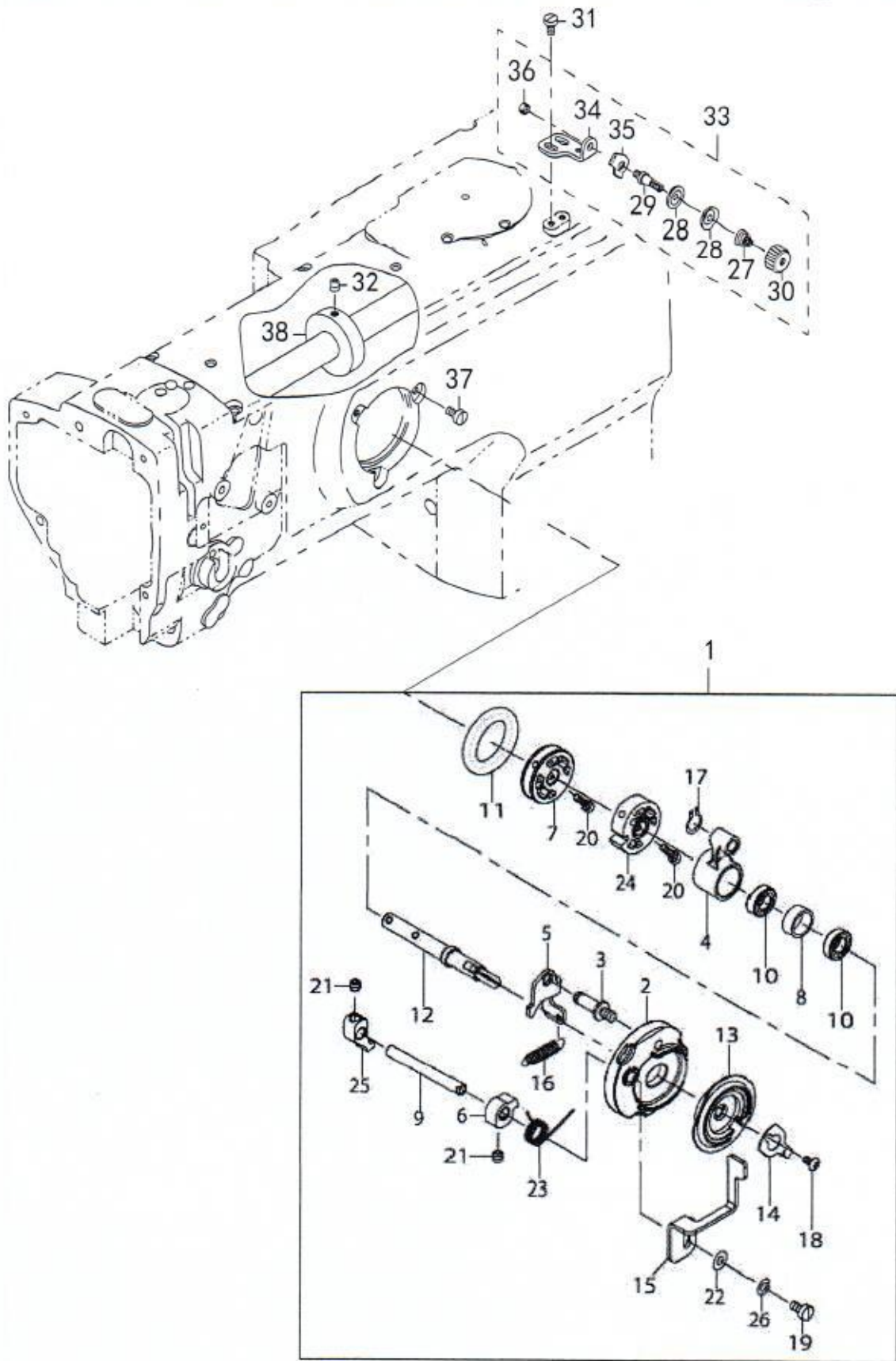

序号	说明	编码及型号	英文名称	中文名称	数量
1		40126355	BOBBIN DEVICE ASM.	绕线器组件	1
2		26260109	BOBBIN FITTING BASIS COMPL.	绕线座	1
3		26260307	ADJUSTING PLATE BEARING	绕线器调节板轴	1
4		26260406	CONNECTING ROD	绕线连杆	1
5		40126594	ADJUSTING PLATE	绕线器调节板	1
6		26260505	STOP MOVING CARD	止动卡	1
7		40125851	WHEEL SHAPE	轮毂	1
8		26260802	RING	挡圈	2
9		26261008	BEARING	轴承	1
10		40126354	BEARING SHAFT	轴承	1
11		26261503	FRICTION RUBBER CIRCLE	摩擦胶圈	1
12		40126550	CENTER BEARING	中心轴	1
13		40125927	RUBBER MAT	胶垫	1
14		40126311	THREAD TRIMMER	断线刀	1
15		40151791	HANDLE	手柄	1
16		13718507	SPRING	拉簧	1
17		RC0560711KP	RING	弹性挡圈	1
18		SM0030601SC	SCREW 3*0.5 L=8	绕线器固定螺钉	3
19		SM6040860TP	SCREW4*8	螺钉	1
20		SM6031202TP	SCREW	螺钉	2
21		SM8050502TP	SCREW	紧定螺钉	1
22		WP0450801SP	FLAT MAT	平垫	2
23		40126549	SPRING	扭簧	1
24		40125928	POSITIONER	定位器	1
25		40125844	LIMITED CARD	限位卡	1
26		WS0451040KP	SPRING WASHER	弹垫	1
27		NS6110310SP	TENSION SPRING NO. 1	过线夹线簧	1
28		D3168555HOB	BOBBIN WINDER TENSION DISC	过线夹线板	2
29		B3214047000	THREAD TENSION POST	过线桩	1
30		21378708	THREAD TENSION NUT	过线调节螺母	1
31		11072402	SCREW	小夹线固定螺钉	2
32		SM8050602TP	SCREW M5 L=6	梭芯绕线轮(上轴)螺钉	2
33		22538706	LOWER THREAD GUIDE ASM.	过线组件	1
34		21355706	FITTING BASE	底线过线架	1
35		D3162555B00	THREAD GUIDE	过线板	1
36		NS6110310SP	NUT 11/64-40	过线桩螺母	1
37		SS6110810TP	SCREW 11/64-40 L=8	绕线器固定螺钉	3
38		10704807	BOBBIN FRICTION WHEEL	梭芯绕线轮(上轴)	1

10. 供油装置 (Lubrication components)

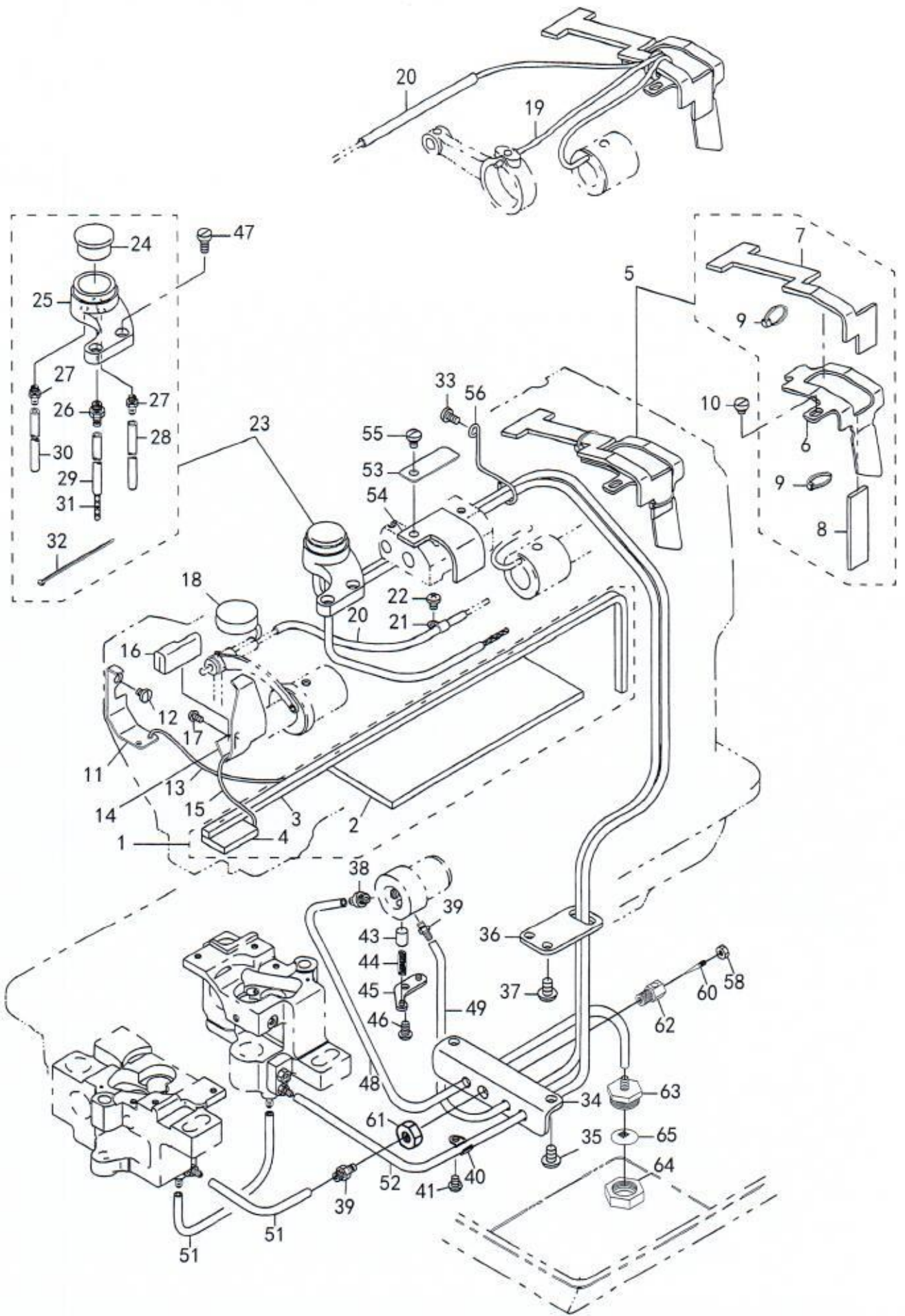

序号	说明	编码及型号	英文名称	中文名称	数量
1		21345756	ARM ONCE THROUGH OIL FELT ASM.	蓄油毡组件	1
2		21345707	ARM ONCE THROUGH FELT A	蓄油毡A	1
3		21345806	FELT B	蓄油毡B	1
4		21345905	FACE ONCE THROUGH FELT	蓄油毡C	1
5		21346358	FELT SUPPORT ASM.	大油毡架组件	1
6		21346309	FELT	大油毡架	1
7		21346507	FEED CHANGE FELT	大油毡组件A	1
8		21346408	FELT	大油毡组件B	1
9		EA9500B0000	CLIP CV-70S	尼龙自锁夹	2
10		SS7110710SP	SCREW 11/64-40 L=4.3	大油毡架螺钉	1
11		21340708	UPPER FEED OIL BAR PLATE	后防油板	1
12		SS7110710SP	SCREW 11/64-40 L=5	后防油板螺钉	1
13		CQ202000000	OIL WICK	后防油板油线	0.2
14		21347000	TAKE-UP OIL PLATE	前防油板	1
15		CQ202000000	OIL WICK	前防油板油线	0.25
16		21347208	TAKE-UP LUBRICATION FELT	前防油板海绵油毡	1
17		SS3090610SP	SCREW 9/64-40 L=6	前防油板螺钉	1
18		21346002	FELT	上轴大油芯	1
19		CQ202000000	OIL WICK	油线	0.2
20		BT0600402EA	OIL TUBE	油管	0.12
21		B3538112000	OIL RETURN TUBE HOLDER	油管固定板	1
22		SS4110615SP	SCREW 11/64-40 L=6	油管固定板螺钉	1
23		40051503	ARM OIL TANK ASM.	储油箱组件	1
24		B3520586000	OIL SIGHT WINDOW	油窗	1
25		21345608	ARM OIL TANK	储油箱	1
26		SQ1110401MZ	CONNECTING SCREW	油管连接大螺钉	1
27		SQ1150451MZ	CONNECTING SCREW	油管连接小螺钉	2
28		23630007	TUBE	油管	0.5
29		23630007	TUBE	油管	0.2
30		23630007	TUBE	油管	0.6
31		CQ202000000	OIL WICK	防油板油线	0.7
32		EA9500B0100	CABLE BAND	尼龙自锁夹	3
33		SS7110830SP	SCREW 11/64-40 L= 7.5	油管支架螺钉	1
34		21345103	LUBRICATION BRACKET	润滑架	1
35		SS4150915SP	SCREW 15/64-28 L=9	螺钉	2
36		21345202	OIL PIPE STAY	油管支板	1
37		SS4150915SP	SCREW 15/64-28 L=9	油管支板螺钉	2
38		40064409	CONNECTION SCREW ASM.	油管连接大螺钉	1
39		SQ1110401MZ	CONNECTING SCREW	油管连接小螺钉	1
40		B3538112000	OIL RETURN TUBE HOLDER	油管固定板	1
41		SS4110615SP	SCREW 11/64-40 L=6	油管固定板螺钉	1
42		13765607	OIL CONNec. ARM	三通油管接头	1
43		B3534155000	PLUNGER	吸油柱塞	1
44		B1214038000	PLUNGER SPRING	柱塞簧	1
45		B3524552000	PLUNGER THRUST PLATE	柱塞挡板	1
46		SS4110815SP	SCREW 11/64-40 L=8	柱塞挡板螺钉	1
47		SS6111010SP	SCREW 11/64-40 L= 9.5	滤油螺钉	2
48		23630007	TUBE	油管	0.36
49		23630007	TUBE	油管	0.08
50		23630007	TUBE	油管	0.22
51		23630007	TUBE	油管	0.1
52		23630007	TUBE	油管	0.5
53		21338306	LUBRICATION FELT PRESSER	油毡压片	1
54		SS5090610SP	MUTUAL VERTICAL CHANGE FELT	垂直油毡	1
55		SS5090610SP	SCREW 3/16-28 L= 7.0	油毡压片螺钉	1
56		21346606	PIPE SUPPORT	油管支架	1
57		EA9500B0100	CABLE BAND	尼龙自锁夹	1
58		010624	NUT 11/64-40	螺母	1
59		10126803	OIL TUBE HOLDER	吸油管弹簧夹	1
60		010623	SCREW	螺钉	1
61		LMS	NUT 8	螺母	1
62		021360	THROTTLE SLEEVE	节流阀套	1
63		021363	OIL FILTER HEAD	滤油头	1
64		021364	COVER	盖帽	1
65		021365	FILTER	滤网	1

11、自动抬压脚装置(选配) (AUTOMATIC PRESSER LIFTING MECHANISM COMPONENTS) (OPTIONAL PARTS)

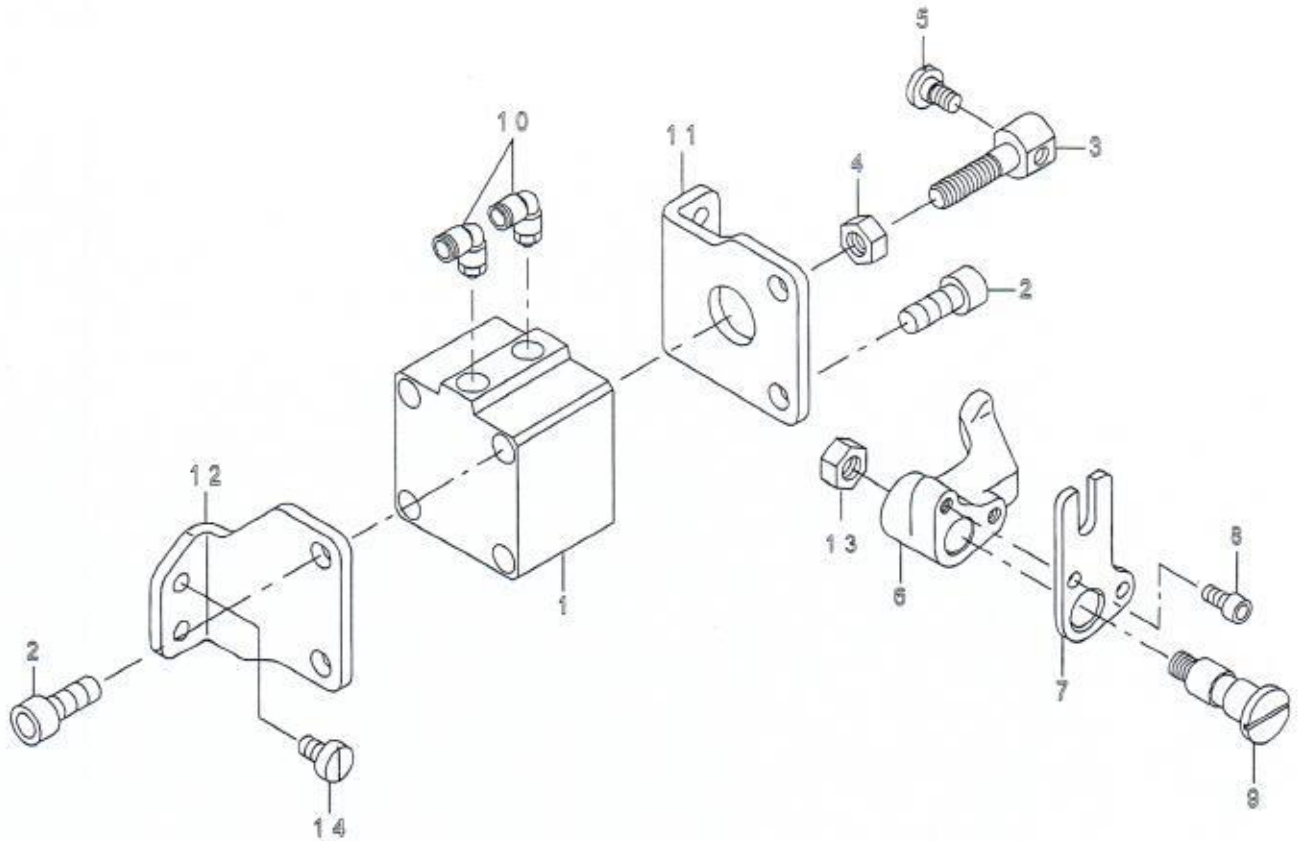

序号	说明	编码及型号	英文名称	中文名称	数量
1		PA400150100	AIR CYLINDER	抬压脚气缸M8	1
2		LS8A20	SCREW M8 L=20	气缸安装螺钉	4
3		21356506	CYLINDER CONNECTING SCREW	抬压脚气缸接头	1
4		LM8	NUT M8	螺母	1
5		SD0720331SP	HINGE SCREW D=7.24 H=3.3	抬压脚气缸接头螺钉	1
6		21388509	PRESSER LIFTER LEVER A	气动抬压脚曲柄	1
7		21356803	PRESSER LIFTER LEVER B	气动抬压脚拨叉	1
8		LS5A10	SCREW M5X0.8 L=10	拨叉固定螺钉	2
9		21356704A	SHAFT	气动抬压脚曲柄螺钉	1
10		SPL6-1	ELBOW UNION 6XPT1/8	螺纹接头	2
11		21356308	CYLINDER STAY(FRONT)	抬压脚气缸安装架(前)	1
12		21356407	CYLINDER STAY(REAR)	抬压脚气缸安装架(后)	1
13		21356704B	SCREW 5/16-T24	螺母5/16-24T	1
14		SS6151210SP	SCREW 15/64-28 L=10	螺钉	4

12. 线架(Thread stand components)

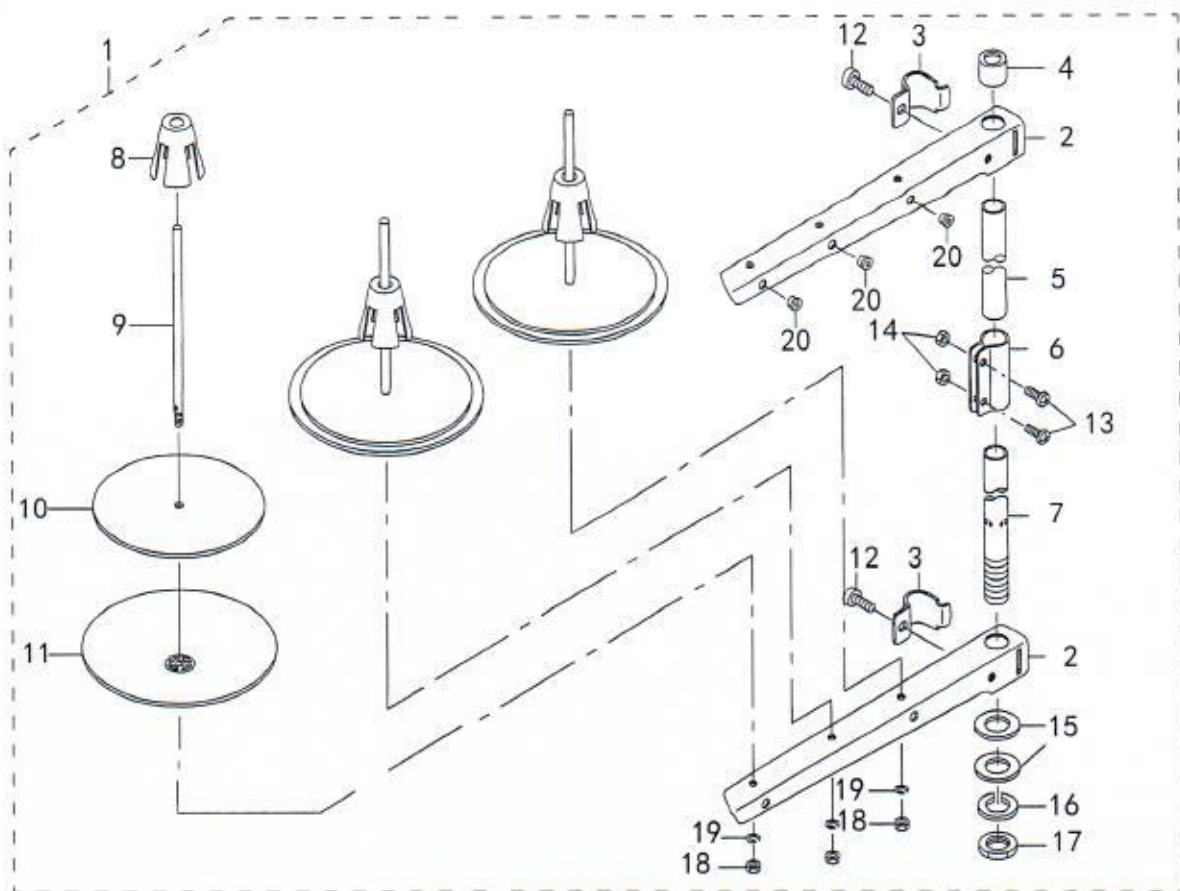

序号	说明	编码及型号	英文名称	中文名称	数量
1		26910158	THREAD STANDING DEVICE ASM.	线架组件	1
2		22930507	SPOOL REST ARM	线架臂	<2>
3		22930705	THREAD GUIDE ARM JOINT	线架臂接头	<2>
4		22931406	SPOOL REST ROD RUBBER CAP	橡胶帽	<1>
5		22930408	SPOOL REST ROD UPPER	上拉杆	<1>
6		22931307	SPOOL REST ROD JOINT	静止杆接头	<1>
7		22930309	SPOOL REST ROD LOWER	下拉杆	<1>
8		22931109	SPOOL RETAINER	阀芯固定	<3>
9		22931000	SPOOL PIN	阀芯销	<3>
10		22930903	SPOOL REST CUSHION	垫	<3>
11		22930804	SPOOL REST	线架	<3>
12		SM6061610SC	SCREW M6 L=16	螺钉	<4>
13		SM4051405SE	SCREW M5 L=14	螺钉	<2>
14		NM6050001SE	NUT M5	螺母	<2>
15		WP1612616SE	WASHER 16X30X2.6	平垫	<2>
16		WS1643202KR	SPRING WASHER	弹垫	<1>
17		NM6160511SE	NUT M16X1.5	螺母	<1>
18		NM6050001SE	NUT M5	螺母	<3>
19		WS0510002KN	SPRING WASHER	弹垫	<3>
20		WS1643202KP	THREAD GUIDE	导线器	3

13. 自动倒缝装置 (Automatic back components)

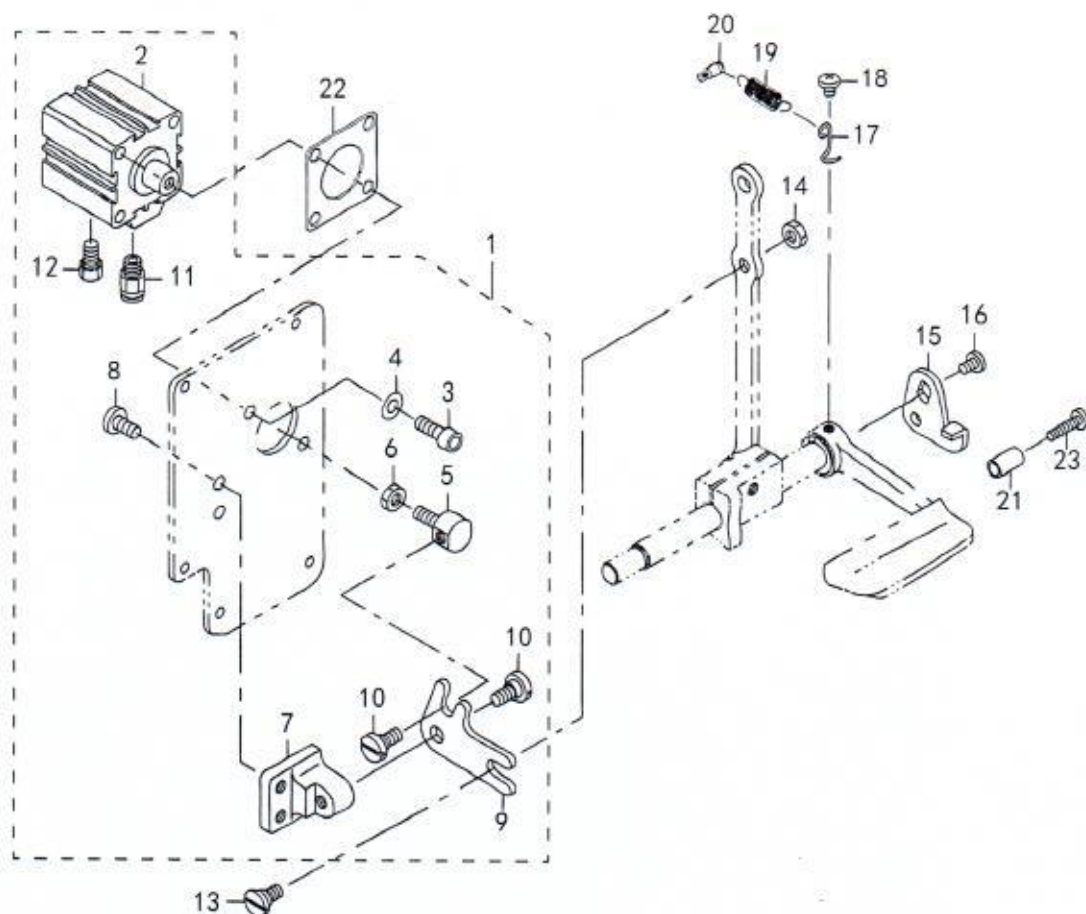

序号	说明	编码及型号	英文名称	中文名称	数量
1		21348958	WINDOW PLATE ASM.	倒缝气缸装置	1
2		PA320150200	JIG CYLINDER	倒缝气缸	1
3		LS6A16	SCREW M6 L=16	气缸安装螺钉	2
4		PD6	WASHER 6	垫圈	2
5		21348602	CYLINDER CONNECTING SCREW	倒顺针距气缸传动螺钉	1
6		LM6	NUT M6	螺母	1
7		21348503	FITTING BASE	倒缝拨叉座	1
8		SS7151210SP	SCREW 15/64-28 L=12	倒缝拨叉座螺钉	2
9		21348701	BACKWARD FEED LINK	倒缝针距拨叉	1
10		SD0800352SP	HINGE SCREW D= 8 H= 3.5	倒缝针距拨叉传动螺钉	2
11		SPC6-1	HALF UNION	直接头	1
12		PST01	MUFFLER	消音器	1
13		SD0800402TP	HINGE SCREW D= 8 H= 4	倒顺针距拨叉铰链螺钉	1
14		NS6150430SP	NUT 15/64-28	螺母	1
15		22656102	REVERSE FEED LINK (1)	倒缝扳手连接板	1
16		SS7120760SP	SCREW 3/16-28 L= 7.0	倒缝扳手连接板螺钉	1
17		22656003	SPRING SUSPENSION	倒缝扳手拉簧勾	1
18		SS4120615SP	SCREW 3/16-28 L=6	拉簧勾螺钉	1
19		13515606	SPRING	倒缝扳手拉簧	1
20		10120004	SPRING SUSPENSION	拉簧螺钉	1
21		11100500	REVERSE FEED LEVER STOPPER	倒缝扳手限位套	1
22		21349105	CYLINDER PACKING	防油垫	1
23		SS7111810SP	SCREW 11/64-40 L=18	螺钉	1

14. DL装置(DL mechanism components)

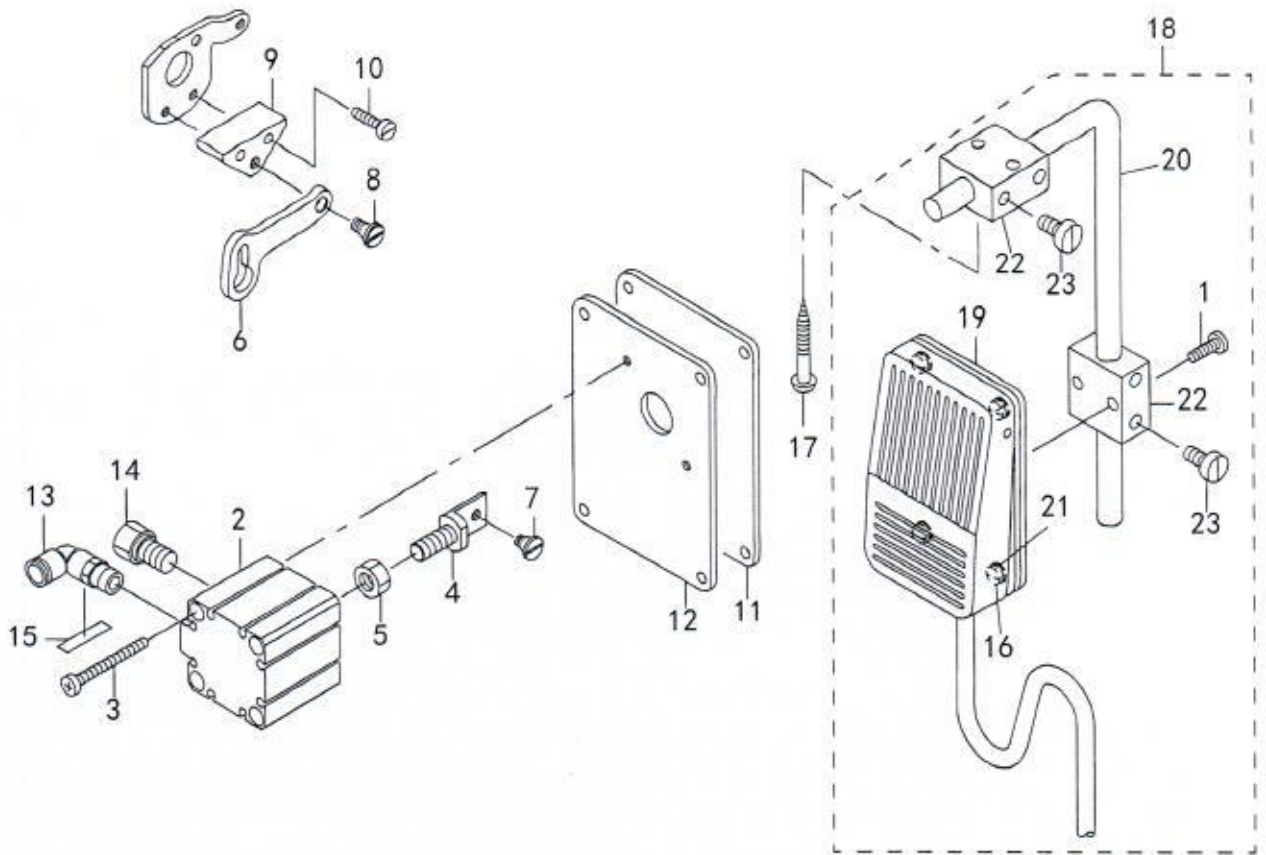

序号	说明	编码及型号	英文名称	中文名称	数量
1		LS5A14	SCREW 5X14	螺钉	2
2		PA320200100	JIG CYLINDER	气缸	1
3		SM6044002TP	SCREW	气缸安装螺钉	2
4		21438403	CYLINDER CONNECTING SCREW	控制连接螺钉	1
5		LMS	NUT M8	螺母	1
6		21438502	MUTUAL VERTICAL LINK	连杆	1
7		SD0600403TP	HINGE SCREW	螺钉	1
8		SD0600454TP	SHOULDER SCREW	螺钉	1
9		21438601	MUTUAL VERTICAL LINK SPASER	连接安装座	1
10		SS6111610SP	SCREW 11/64-40 L=16	安装座螺钉	2
11		21437306	WINDOW PLATE E PACKING	油垫	1
12		21437207	WINDOW PLATE F	后窗板	1
13		SPL6-1	ELBOW	弯接头	1
14		PST-01	MUFFLER	消音器	1
15		HX00295000C	WIRE MARK (4)	气管标记	4
16		SS7110710SL	SCREW 11/64-40 L=7.0	螺钉	4
17		SK3514000SC	WOOD SCREW D=5.1 L=40	木螺钉	2
18		40025036	KNEE SWITCH ASM.	膝控系统	1
19		40025035	KNEE SWITCH ASM.	膝控组件	1
20		MAT80231T00	DRIVING BAR T002	驱动杆	1
21		WP0480856SP	WASHER 4.8X8.4X0.8	垫圈	4
22		MAT80230T00	KNEE SWITCH SUPPORT BASE	膝控支撑块	2
23		LS5A16	SCREW 5X16	螺钉	4

15. 供气装置 (Air mechanism components)

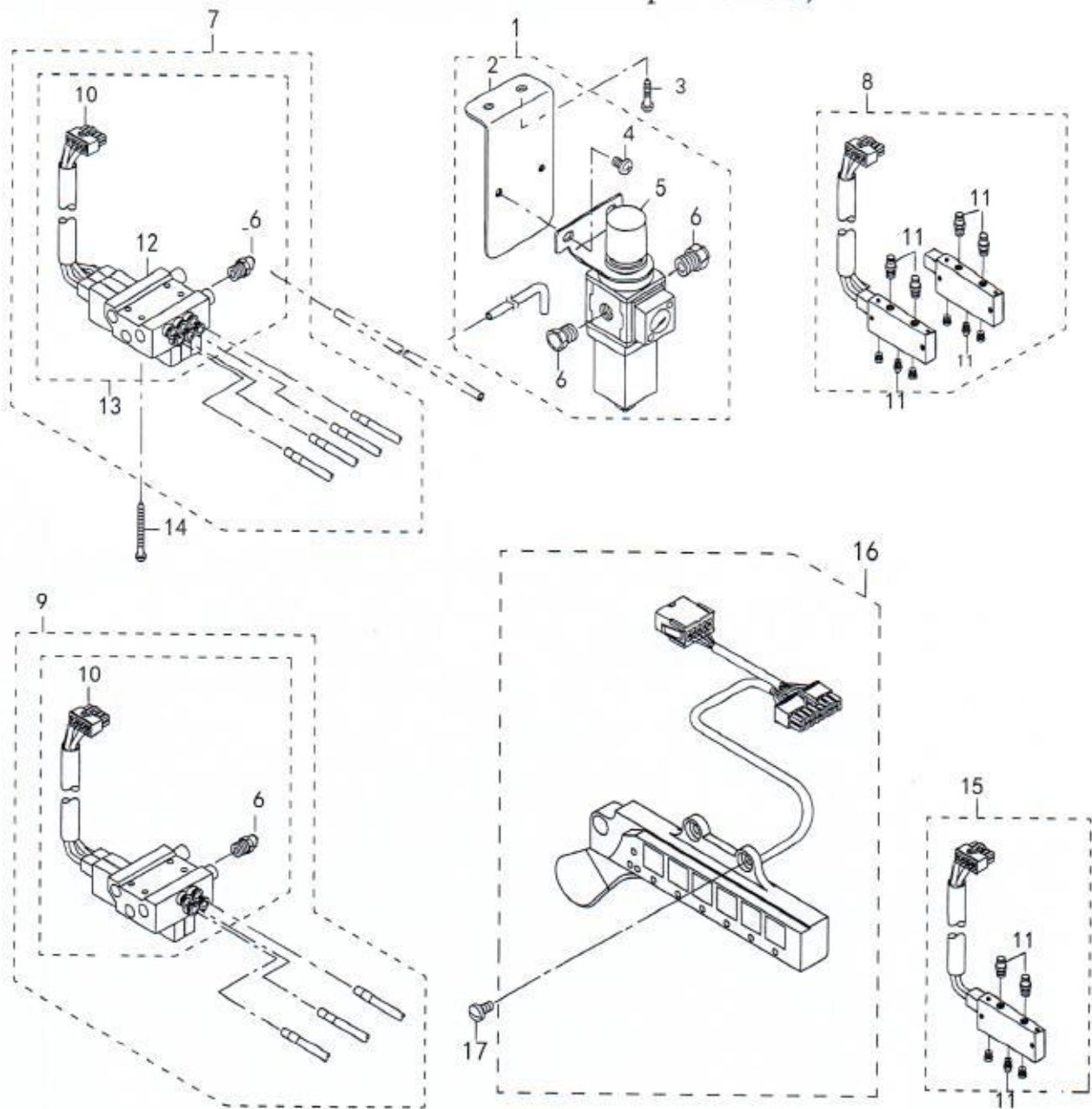

序号	说明	编码及型号	英文名称	中文名称	数量
1		021701	AIR APPARATUS (B) ASM.	供气系统	1
2		021702	Mounting panel	安装板	3
3		SK3514000SC	SCREW D=4.1 L=20	木螺钉	6
4		021704	SCREW M6 L=10	螺钉	4
5		PF0552170A0	FILTER REGULATOR	气源控制及过滤器	2
6		SPC8-02	NIPPLE	接头	6
7	#03	021709	ELECTROMAGNETIC VALVE ASM.	气动控制系统	1
8		021709A	ELECTROMAGNETIC VALVE ASM.	气动控制系统	1
9	#01	021709B	ELECTROMAGNETIC VALVE ASM.	气动控制系统	1
10		021710	RECEPTACLE	插头	<3>
11		SPL6-02	NIPPLE	接头	9
12		021712	FILTER REGULATOR MOUNTING PLAT	安装座	<1>
13		021713	ELECTROMAGNETIC VALVE (C) ASM.	气动控制组件	1
14		021714	SCREW D=4.1 L=50	木螺钉	4
15		021716	ELECTROMAGNETIC VALVE ASM.	气动控制系统	1
16		021654	5RANGE SWITCH ASM.	六联按钮组件	1
17		SS7110710SP	SCREW	螺钉	3

#01 1580A用 #03 1580A-7用

16. 附件 (Accessories parts components)

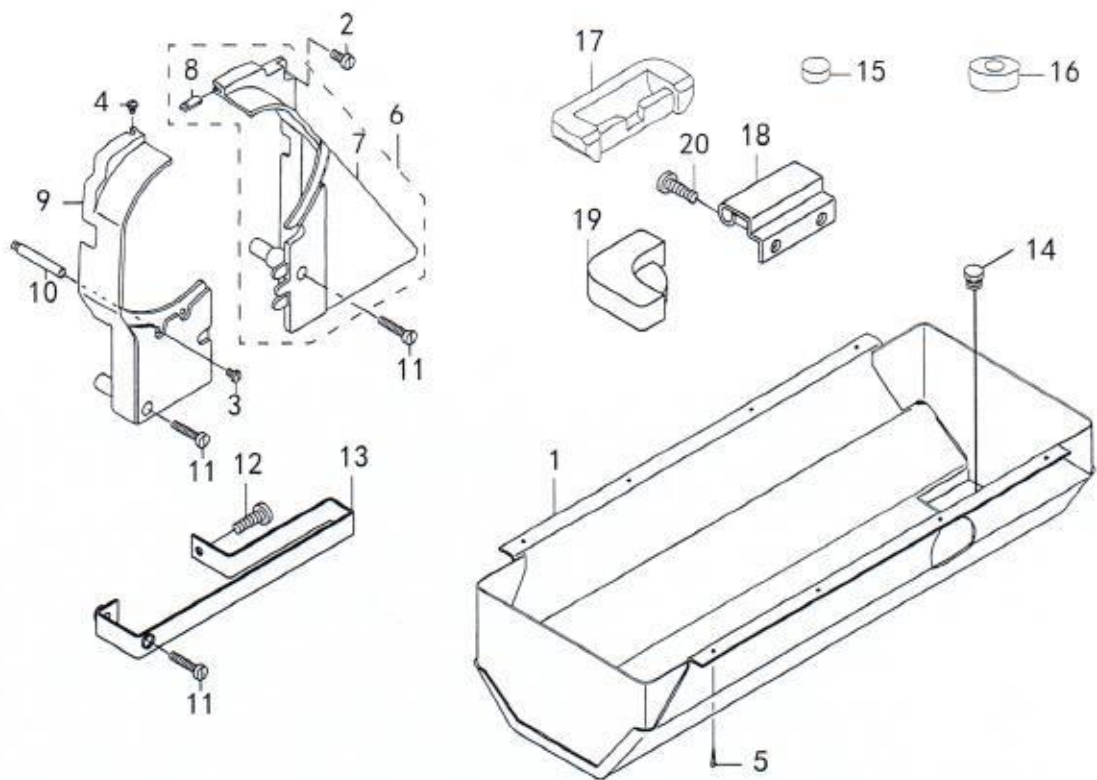

序号	说明	编码及型号	英文名称	中文名称	数量
1		21351457	OIL RESERVOIR ASM.	大油盘	1
2		SS6151440SP	SCREW 15/64-28 L=14	皮带罩螺钉	1
3		SS7110840SP	SCREW 11/64-40 L=7.8	皮带罩螺钉	1
4		SS5110740TP	SCREW 11/64-40 L= 6.5	皮带罩连接螺钉	1
5		SK3241601SC	WOOD SCREW D=2.4 L=16	铁钉	8
6		21351150	BELT COVER ASM. (RIGHT)	皮带罩组件	1
7		21351101	BELT COVER (RIGHT)	皮带罩	1
8		21351002	BELT COVER AUXILIARY PLATE	皮带罩连接块	1
9		21351200	BELT COVER (LEFT)	皮带罩B	1
10		D8232241E00	BELT COVER SUPPORT A	皮带罩撑杆	1
11		SS6153040SP	SCREW 15/64-28 L=30	皮带罩螺钉	3
12		LS6A10	SCREW	螺钉	1
13		021227	Enclosure	防护罩加高件	1
14		021841	Oil plug	油塞	1
15		B820612000	FWLTR CUSHION	防震垫	2
16		B820812000	FWLTR CUSHION	防震垫	2
17		22926000	RUBBER CUSHION	机壳铰链套	2
18		22926356A	HINGE COMPL.	安装扣	2
19		907010050	Rubber pad	胶垫	2
20		LS6A12	SCREW	螺钉	4



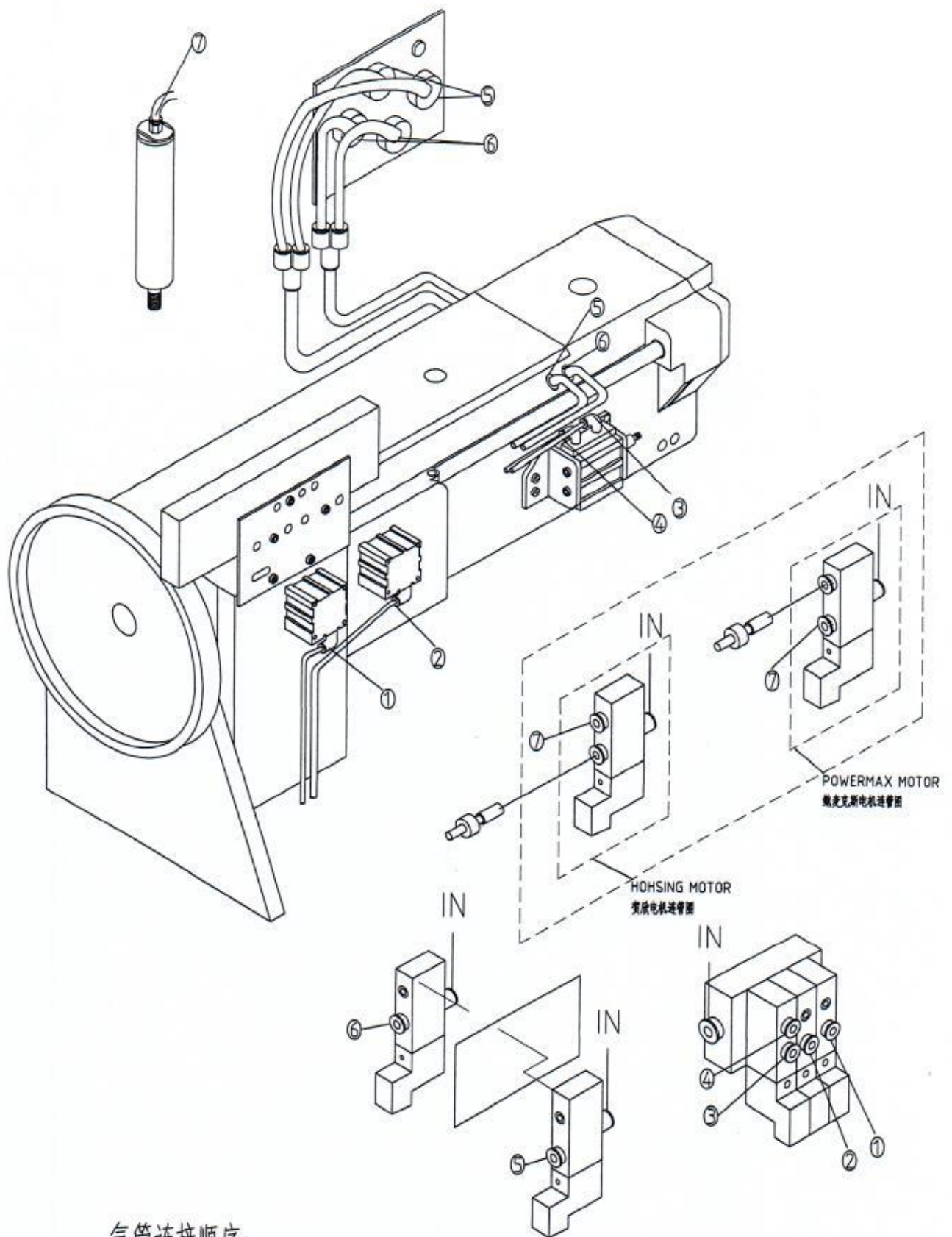





17. 气管连接图



气管连接顺序:

- ①-① ②-② ③-③ ④-④ ⑤-⑤ ⑥-⑥ ⑦-⑦

18. 附件：针位 (Needle gauge)

内压脚 Top feeder	内压脚 Top feeder	外压脚 (气动中分) Presser foot
 1760E06A 6 mm 1760E08A 8 mm 1760E10A 10mm 1760E12A 12mm 1760E14A 14mm	 1760E306A 6 mm 1760E308A 8 mm 1760E310A 10mm 1760E312A 12mm	 1760E306B-Q 6 mm 1760E308B-Q 8 mm 1760E310B-Q 10mm 1760E312B-Q 12mm
外压脚 (右靠边) Presser foot	外压脚 Presser foot	针头 Needle head
 1760E06BR 6 mm 1760E08BR 8 mm 1760E10BR 10mm 1760E12BR 12mm 1760E14BR 14mm	 1760E06B 6 mm 1760E08B 8 mm 1760E10B 10mm 1760E12B 12mm 1760E14B 14mm	 1760E06C 6 mm 1760E08C 8 mm 1760E10C 10mm 1760E12C 12mm 1760E14C 14mm
针板 Needle plate	送布牙 Feed dog	
 1580E06D 6 mm 1580E08D 8 mm 1580E10D 10mm 1580E12D 12mm 1580E14D 14mm	 1580E06E 6 mm 1580E08E 8 mm 1580E10E 10mm 1580E12E 12mm 1580E14E 14mm	

