

GLOBAL

SM 7555 OS

DOUBLE NEEDLE SIDE SEAM

INSTRUCTION MANUAL

Thank you very much for your choice of this double thread side seam sewing machine. Please read the manual carefully before use!



Ensure that the rotation of the pulley conformable to the red arrow on the belt cover!

Notice: Replace or installation motor belt should pay attention and v-belts can not be adjusted too tight, synchronous belt can not be adjusted too loose!

Main Warnings:

- ♥It is extremely important that the electrical device must be soundly earthed!
- ♥It is absolutely forbidden to remove any protection system provided by manufacturer while machine is on!
- ♥All setting and replacement operation must be carried out only by the qualified expert personnel!
- ♥For repairs, all tools and replacement parts must be qualified by manufacturer!
- ♥Whenever, and whatever reason, the machine is to be demolished, certain basic rules must be observed to safeguard public health and the environment in which we live!

CONTENTS

1. MACHINE DESCRIPTION	1
2. TECHNICAL FEATURES OF THE MACHINE	1
3. USE OF THE MACHINE	1
3.1 Start pedal	1
3.2 Threading needle thread	2
3.3 Adjustments setting of stitch length	2
4. ADJUSTMENT SETTING OF THE MACHINE	3
4.1 Set sewing pattern	3
4.1.1 Change and set the needle-change cam	3
4.1.2 Change and set the transport cam	4
Attachment: Parts Drawings	6

Thank you very much for choosing our machine. Please read the instruction book carefully before use!

1. MACHINE DESCRIPTION

SM 7555 OS double needle sewing machine is a specially designed shoe border stitcher with miscellaneous sewing patterns. 12 sewing patterns can be set according to operator's requirement. The machine is driven by the servo motor; the sewing speed can be changed stepless. The stop position of the machine is controlled by computer of the motor.

2. TECHNICAL FEATURES OF THE MACHINE

Max sewing speed:	400 RPM
Stitch length:	4-12mm
Needle :	CP×5 (25# / 27#)
Motor:	750W / 220V single-phase
Net weight:	195kg (N.W.)
Machine dimensions:	117cm×64cm×140cm (L.×W.×H.)

3. USE OF THE MACHINE

3.1 Start pedal

First of all, switch on the machine to watch if the rotation of motor is conformable to the red arrow on the belt cover. Then operate the pedal in three different movements (Fig 1)

- Stepping on forward (Position A) means advance. Stepping on lightly is slow and stepping on heavily is fast. Avoid stepping on heavily at the very beginning.
- Stop in the neutral position
- Stepping on backward (Position B) means lifting the presser foot.

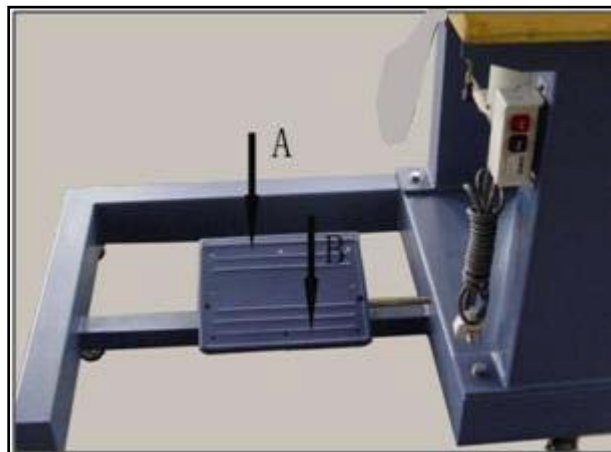

Fig.1

3.2 Threading needle thread

To prepare the needle thread, proceed as follows:

- Turn the pulley in the correct direction so that the needle comes to its highest position.
- Threading the needle thread by the path indicated in **Fig.2**

(1) Threading rod (2) Threading rod (3) Thread gripping holder (4) Threading rod (5) Tightener (6) Threading wheel (7) Take-up leaf (8) Take-up lever (9) Thread carrier (10) Needle holder (11) Needle

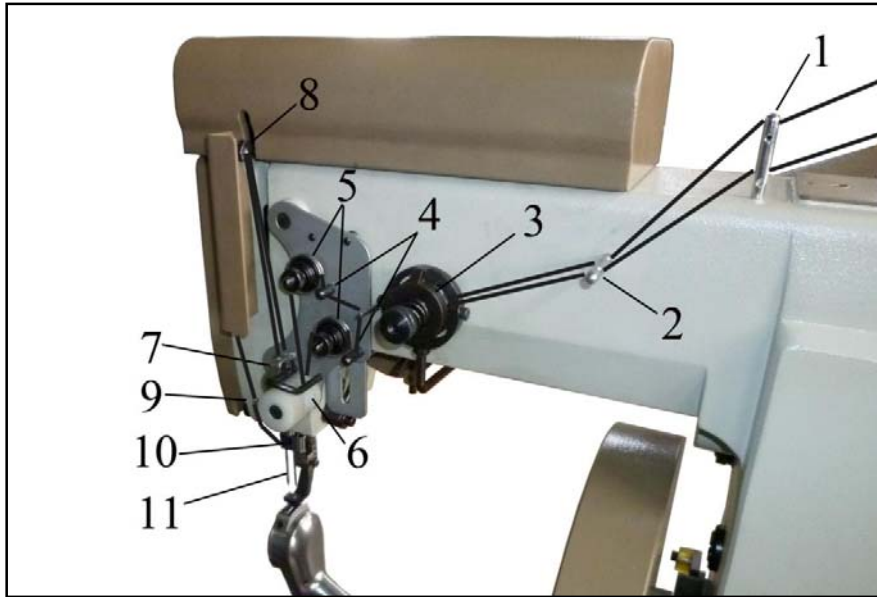

Fig.2

3.3 Adjustments setting of stitch length (Fig.3)

To adjust stitch length of the machine, procedure as follows:

- Loosen the nut 1,
- Turn the knob 2, if the slide block 3 moves upward means increase the stitch length; if the slide block 3 moves downward means decrease the stitch length.

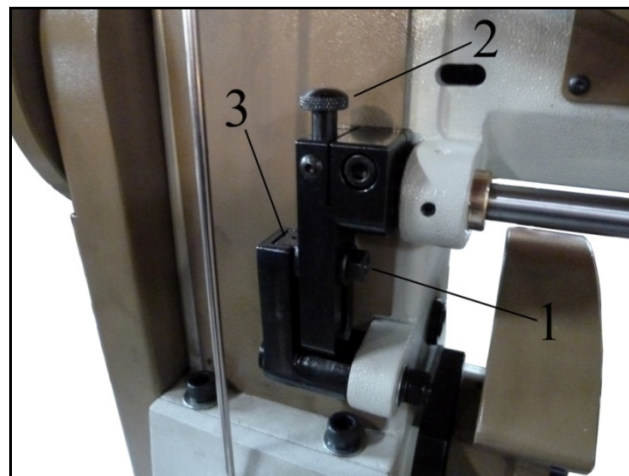

Fig.3

4. ADJUSTMENT SETTING OF THE MACHINE

4.1 Set sewing pattern (pattern table is shown in Fig.8)

4.1.1 Change and set the needle-change cam (Fig.4, Fig.5)

The needle-change cam (188-326A2 or 188-326B1, 188-326B2) must match up the gear (188-325A or 188-325B). **The needle-change cam (188-326A2) must match up the gear (188-325A), and the needle-change cam (188-326B1 or 188-326B2) must match up the gear (188-325B), as shown in Fig.4.**

If the gear (188-325A or 188-325B) need to be changed, the mark on the gear(188-325A or 188-325B) must point to the mark on the gear(188-321) when setting., as shown in Fig.5.

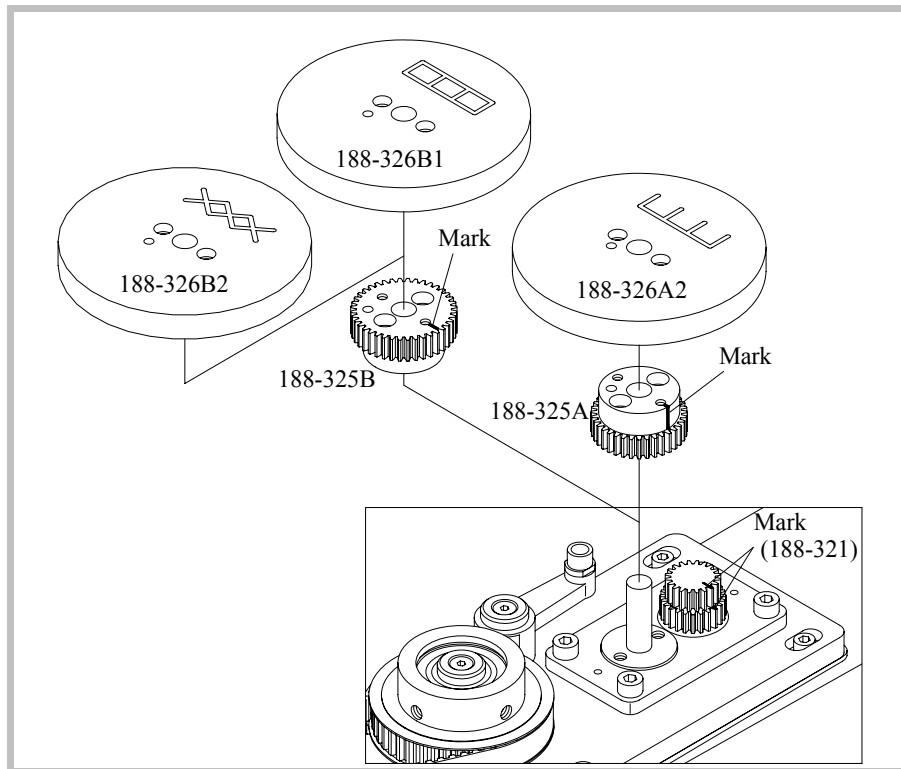

Fig.4

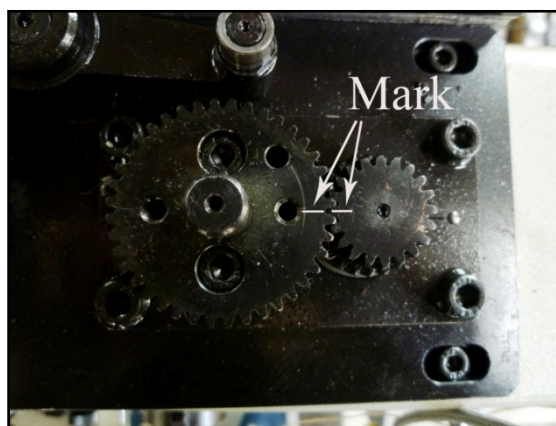

Fig.5

4.1.2 Change and set the transport cam (Fig.6, Fig.7)

The transport cam (188-307A or 188-307B1, 188-307B2) must match up the gear (188-306A or 188-306B). **The transport cam (188-307A) must match up the gear (188-306A), and the transport cam (188-307B1 or 188-307B2) must match up the gear (188-306B), as shown in Fig.6.**

To change and set transport cam, procedure as follows: (Fig.7)

- Remove the rocker pin 1 (188-309) and rocker arm 2 (188-310)
- Remove the screws 3, remove the transport cam 4 and gear 5
- Replace another cam 4 and gear 5
- Fit the rocker arm 2(188-310) and rocker pin 1(188-309) on the machine at last.

If the gear 5(188-306A or 188-306B) is replaced, the transporting movement must be readjusted.

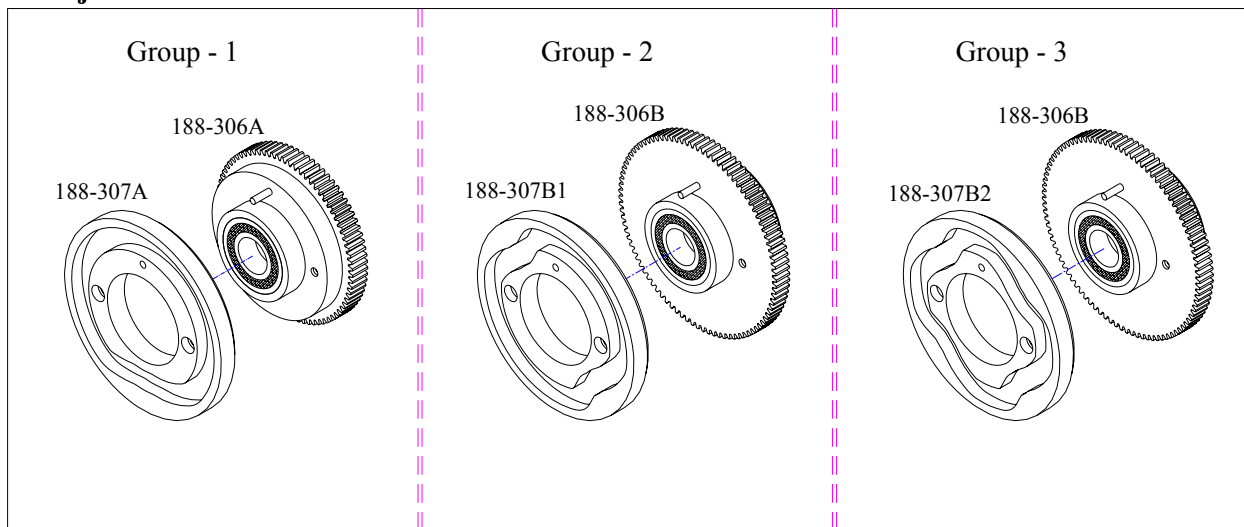

Fig.6

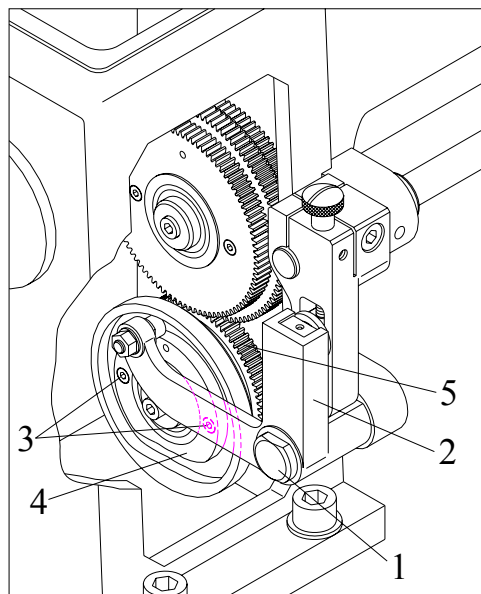
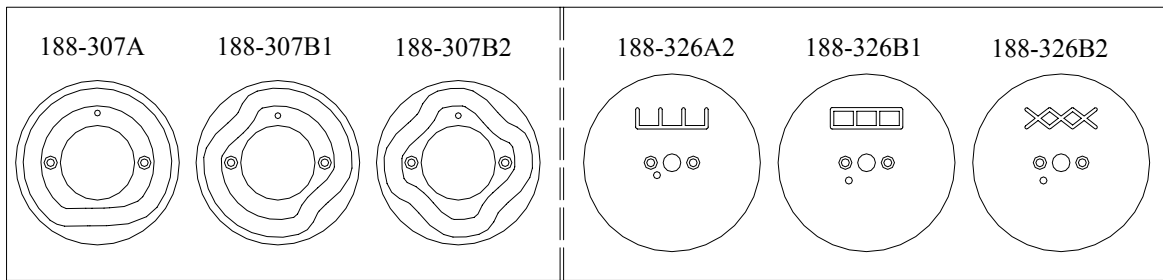
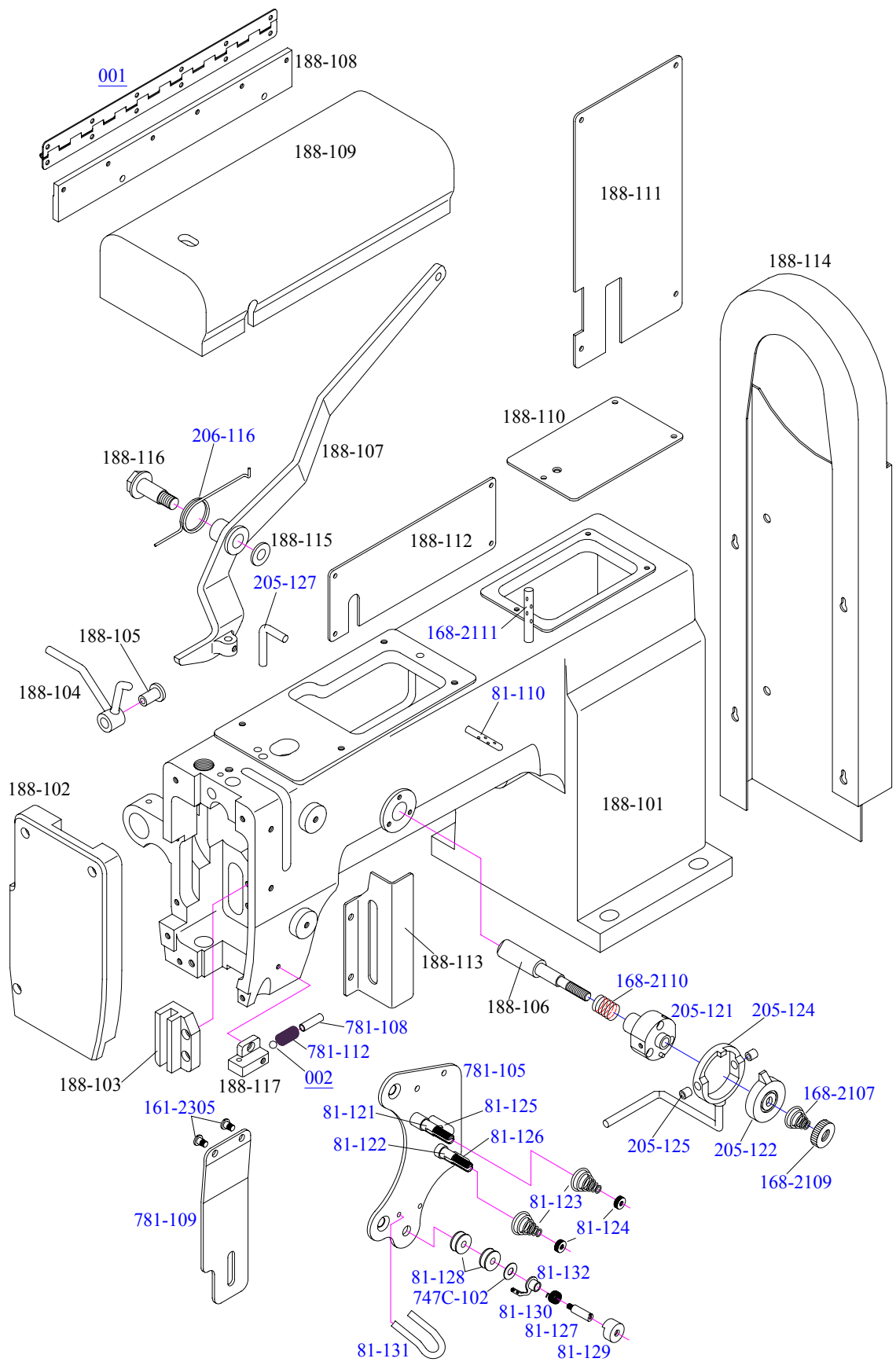

Fig.7



Sewing pattern	Needle-change cam	Transport cam	Needle
	188-326A2	188-307A	1 needle
	188-326B1	188-307B1	2 needles
	188-326B1	188-307B1	1 needle
	188-326B2	188-307B2	2 needles
	188-326B2	188-307B2	1 needle
	188-326B1	188-307B2	2 needles
	188-326B1	188-307B2	1 needle
	188-326B2	188-307B1	2 needles
	188-326B2	188-307B1	1 needle
	188-326B2	188-307A	1 needle
	No rotation	188-307B2	1 needle
	No rotation	188-307B2	2 needles

Fig.8



	Machine part	Quantity
188-101	Frame	1
188-102	Head cover	1
188-103	Runner for needle rod guide	1
188-104	Rocker arm	1
188-105	Sleeve	1
188-106	Crown bar	1
188-107	Presser wheel rocker arm	1
188-108	Bracket for cover	1
188-109	Belt cover	1
188-110	Upper cover	1
188-111	Chain cover	1
188-112	Back cover	1
188-113	Protection cover	1
188-114	Belt cover	1
188-115	Washer	1
188-116	Screwing pin	1
188-117	Threading block	1
161-2305	Screw of lifting lever	2
168-2107	Cone spring	1
168-2109	Nut	1
168-2110	Spring	1
168-2111	Narrowing rod	1
205-121	Fixed sleeve	1
205-122	Clamping sleeve	1
205-124	Loose ends block	1
205-125	Sleeve	2
205-127	Connecting lever	1
206-116	Torsion spring of clamp rocker arm	1
781-105	Threading plate	1
781-108	Column	1
781-109	Thread loosen plate	1
781-112	Spring	1
81-110	Narrowing rod	1
81-112	Nut	2
81-121	Rod of thread tighter(long)	1
81-122	Rod of thread tighter(short)	1
81-123	Cone spring	2
81-125	Thread guider rod(long)	1
81-126	Thread guider rod(short)	1
81-127	Thread take-up spring shaft	1
81-128	Threading wheel	2
81-129	Support	1
81-130	Torsion spring	1
81-131	Thread carrier	1
81-132	Thread take-up spring	1
747C-102	Washer	1
001	Hinge	1
002	S Φ 6 steel ball	1

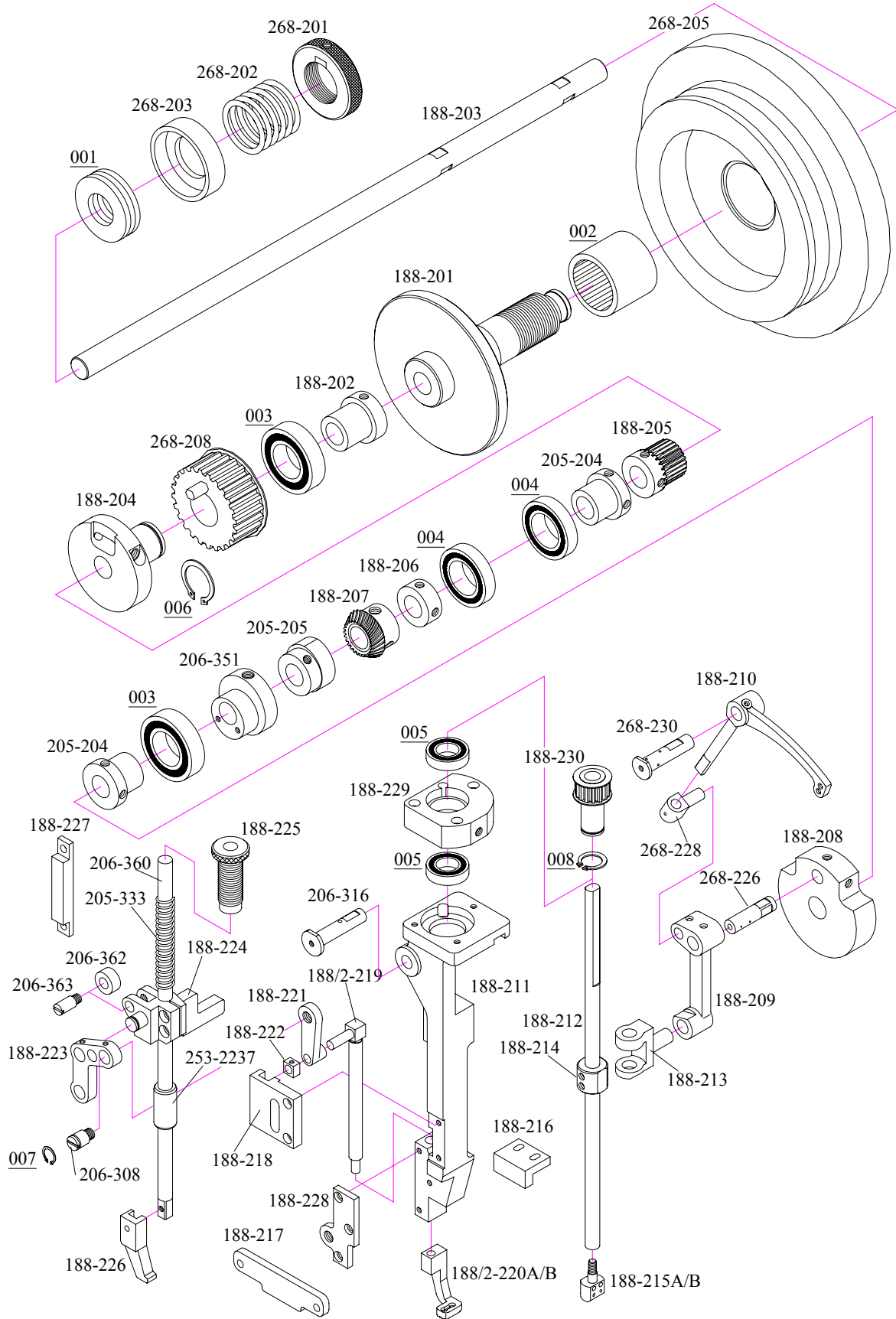

Fig. No.	Machine part	Quantity	Fig. No.	Machine part	Quantity
188-201	Release collar	1	188-229	Flange	1
188-202	Sleeve	1	188-230	Synchronous belt wheel	1
188-203	Central shaft	1	205-204	Sleeve	2
188-204	Driving sleeve	1	205-205	Winding cam	1
188-205	Gear	1	205-333	Spring	1
188-206	Stopping block	1	206-308	Pin	1
188-207	Conical gear	1	206-316	Pin of needle bar supporter	1
188-208	Crank of needle bar	1	206-351	Eccentric gear	1
188-209	Connecting lever	1	206-360	Outer presser foot bar	1
188-210	Thread take-up lever	1	206-362	Roller	1
188-211	Needle bar supporter	1	206-363	Pin	1
188-212	Needle bar	1	253-2237	Sleeve	1
188-213	Spindle with warp for needle rod	1	268-201	Safety clutch setting knob	1
188-214	Joint of needle bar	1	268-202	Spring	1
188-215A	Head end of needle bar (6mm)	1	268-203	Bearing protecting bushing	1
188-215B	Head end of needle bar (7mm)	1	268-205	Belt wheel	1
188-216	Stopper of needle rack	1	268-208	Synchronous belt wheel	1
188-217	Cover plate	1	268-226	Pin	1
188-218	Runner for needle rod guide	1	268-228	Slide sleeve	1
188/2-219	Inner clamping bar	1	268-230	Fixing pin	1
188/2-220A	Inner clamp (6mm)	1	001	Trust bearing 8106	1
188/2-220B	Inner clamp (7mm)	1	002	Roller bearing HK3530	1
188-221	Connecting lever	1	003	Bearing 6005	2
188-222	Slider	1	004	Bearing 61905	2
188-223	Connecting lever	1	005	Bearing 61902	2
188-224	Outer presser foot bar guide	1	006	Shaft ring $\Phi 25$	1
188-225	Adjustable sleeve	1	007	Shaft ring $\Phi 10$	1
188-226	Outer clamp	1	008	Shaft ring $\Phi 10$	1
188-227	Guide plate	1			
188-228	Positioning plate	1			

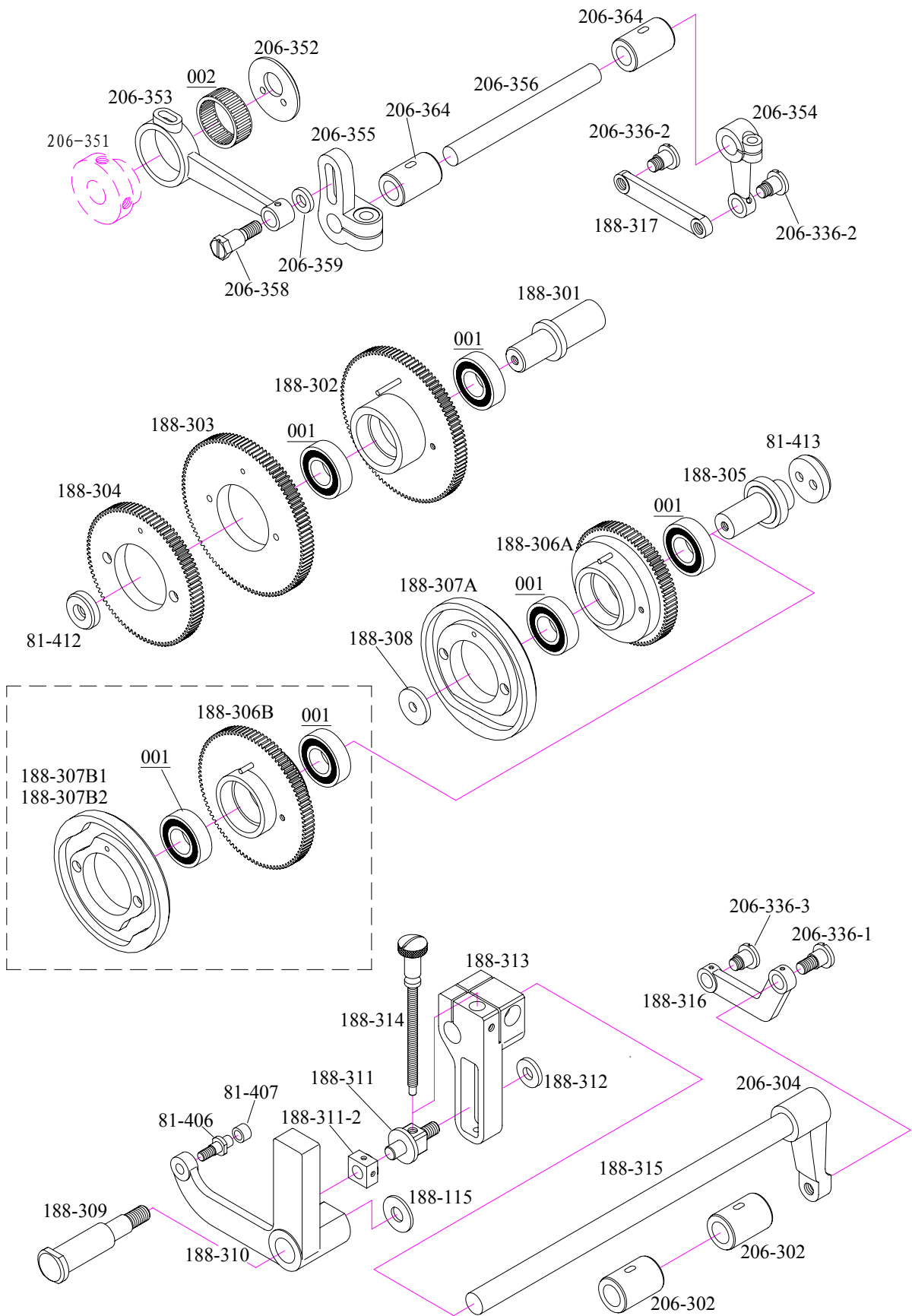

Fig. No.	Machine part	Quantity
188-115	Washer	1
188-301	Pin of idle gear	1
188-302	Idle gear	1
188-303	Cam (1:3)	1
188-304	Cam (1:4)	1
188-305	Eccentric pin	1
188-306A	Gear (1:3)	1
188-306B	Gear (1:4)	1
188-307A	Cam (E)	1
188-307B1	Cam (□)	1
188-307B2	Cam (×)	1
188-308	washer	1
188-309	Rocker pin	1
188-310	Rocker arm	1
188-311	Slider pin	1
188-311-2	Slide block	1
188-312	washer	1
188-313	Rocker arm	1
188-314	Adjusting screw	1
188-315	Shaft	1
188-316	Connecting lever	1
188-317	Connecting lever	1
206-302	Axle sleeve	2
206-304	Rocker arm	1
206-336-1	Screwing pin	1
206-336-2	Screwing pin	2
206-336-3	Screwing pin	1
206-351	Eccentric gear	
206-352	Cover plate	1
206-353	Connecting lever	1
206-354	Rocker arm	1
206-355	Crank	1
206-356	Shaft	1
206-358	Pin	1
206-359	washer	1
206-364	Axle sleeve	2
81-406	Roller pin	1
81-407	Roller	1
81-412	washer	1
81-413	Fixed block	1
001	Bearing 6003	6
002	Roller bearing K30×35×13	1

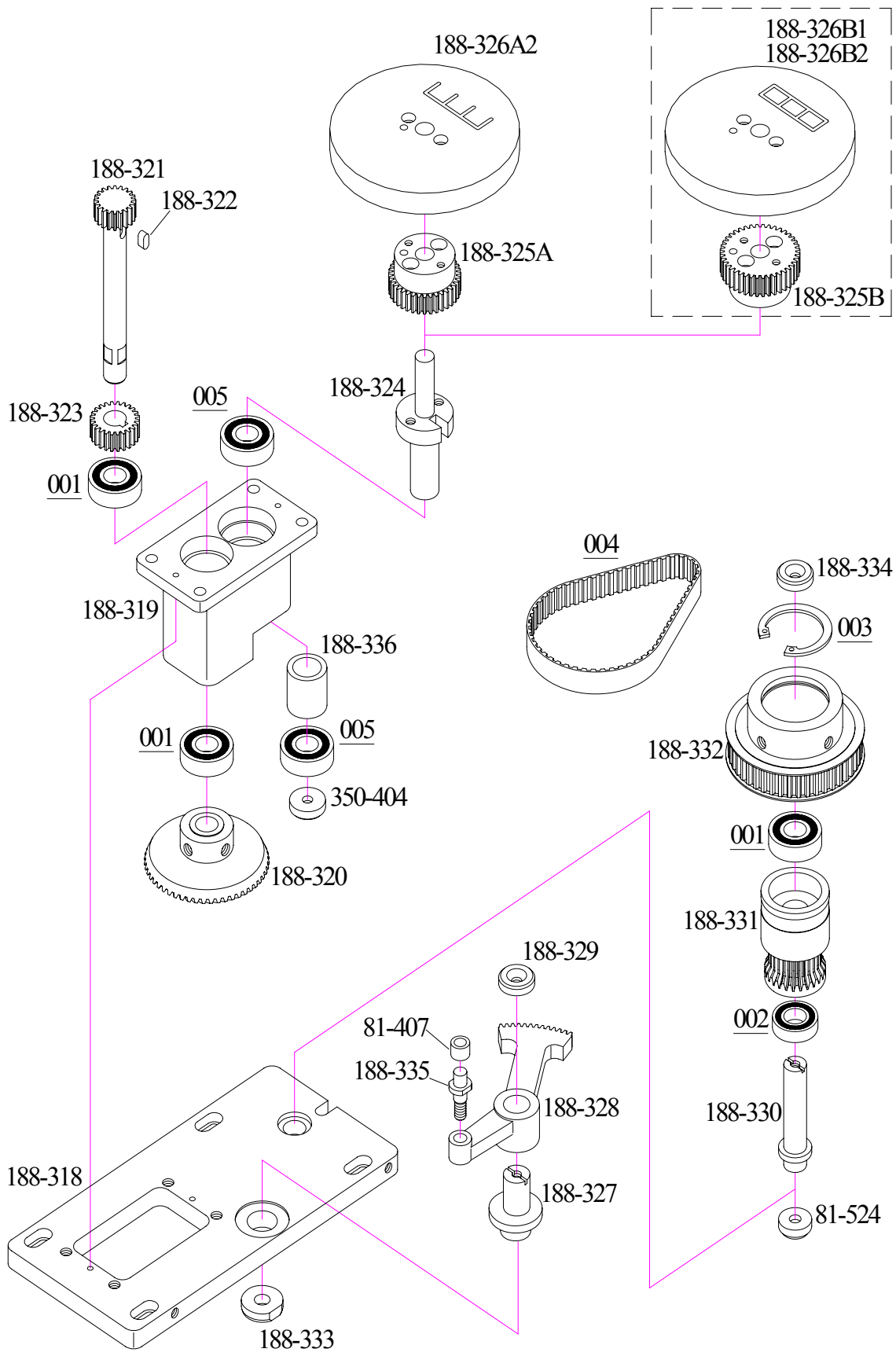

Fig. No.	Machine part	Quantity
188-318	Base plant	1
188-319	Bracket	1
188-320	Conical gear	1
188-321	Gear	1
188-322	Flat key	1
188-323	Gear	1
188-324	Shaft	1
188-325A	Gear (1:3)	1
188-325B	Gear (1:4)	1
188-326A2	Cam (E)	1
188-326B1	Cam (□)	1
188-326B2	Cam (×)	1
188-327	Pin	1
188-328	Rocker arm	1
188-329	washer	1
188-330	Pin	1
188-331	Idle gear	1
188-332	Synchronous belt wheel	1
188-333	washer	1
188-334	washer	1
188-335	Roller pin	1
188-336	Clamping ring	1
81-407	Roller	1
81-524	Washer	1
350-404	washer	1
001	Bearing 6001	3
002	Bearing 61901	1
003	Hole ring $\Phi 36$	1
004	Synchronous belt T5×280×12	1
005	Bearing 61902	2

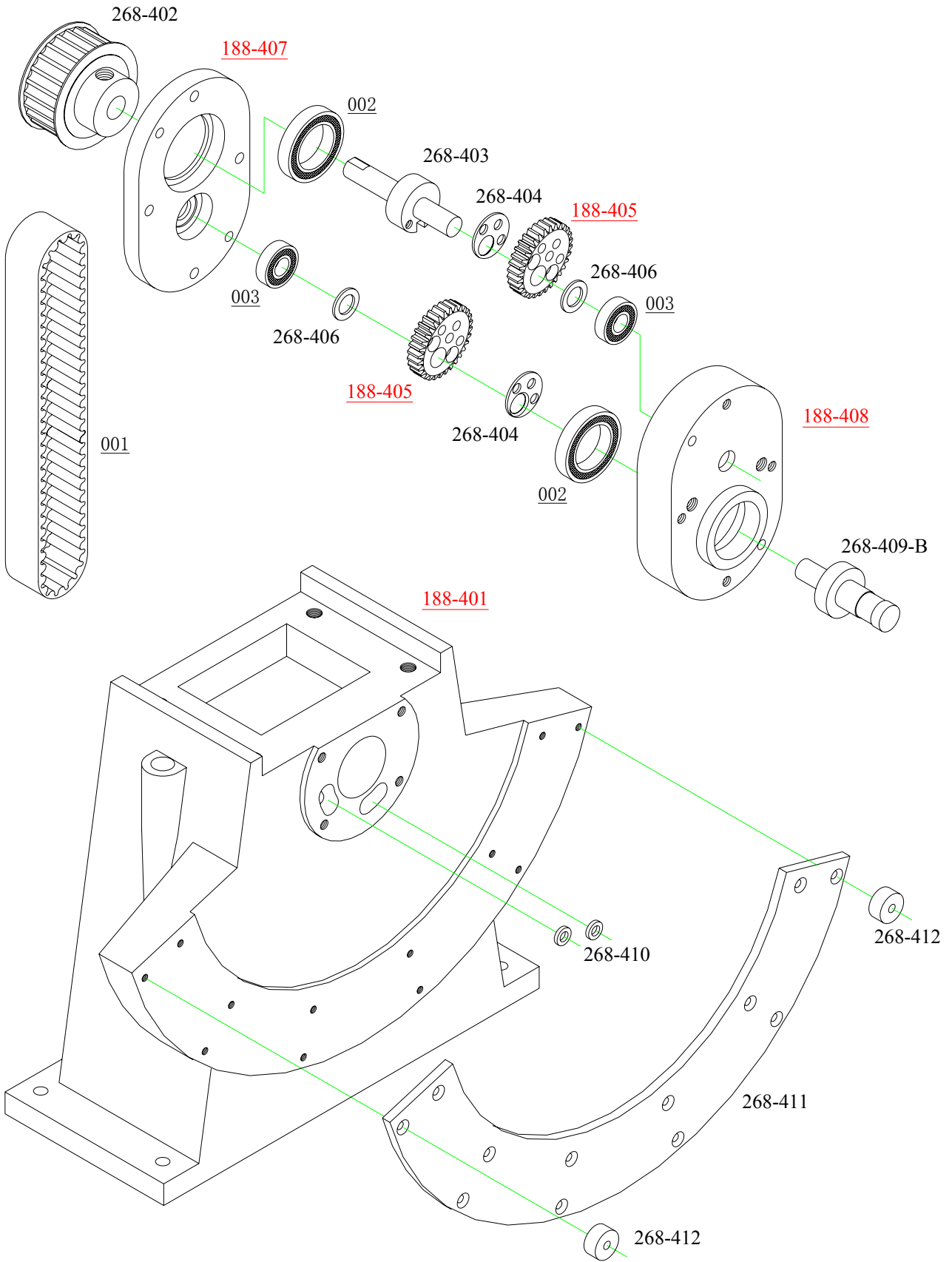

Fig. No.	Machine part	Quantity
<u>188-401</u>	Frame	1
268-402	Synchronous belt wheel	1
268-403	Elliptic gear shaft	1
268-404	Spacer	2
<u>188-405</u>	Elliptic gear	2
268-406	Washer	2
<u>188-407</u>	Cover of elliptic gear casing	1
<u>188-408</u>	Elliptic gear casing	1
268-409-B	Elliptic gear shaft	1
268-410	Spacer	2
268-411	Arc plate	1
268-412	Stopping block	2
001	Synchronous belt S8M×760×24	1
002	Bearing 6006	2
003	Bearing 6001	2

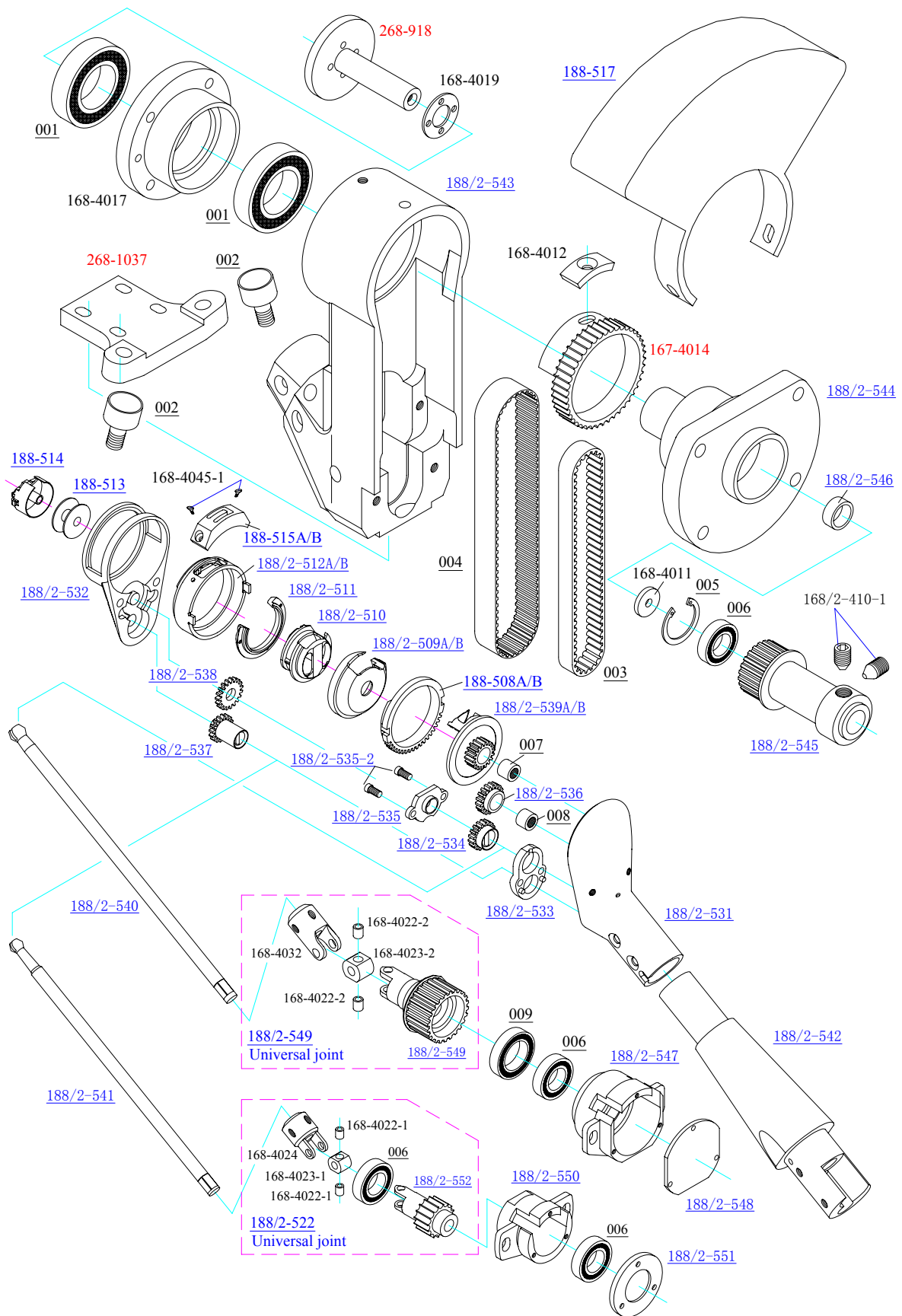

Fig. No.	Machine part	Quantity	Fig. No.	Machine part	Quantity
188/2-531	Head end of bent holder	1	188/2-512A	Shuttle stand (6mm)	1
188/2-532	Cover of bent holder	1	188/2-512B	Shuttle stand (7mm)	1
188/2-533	Support of gear	1	188-508A	Geared ring (6mm)	1
188/2-534	Gear (drive shuttle)	1	188-508B	Geared ring (7mm)	1
188/2-535	Cover of gear	1	188-513	Bobbin	2
188/2-535-2	Screw	1	188-514	Bobbin cover	1
188/2-536	Driver gear(drive shuttle)	1	188-515A(25#)	Needle plate (6mm-25#)	1
188/2-537	Gear (needle plate)	1	188-515A(27#)	Needle plate (6mm-27#)	1
188/2-538	Driver gear(needle plate)	1	188-515B(25#)	Needle plate (7mm-25#)	1
188/2-539A	Shuttle driver (6mm)	1	188-515B(27#)	Needle plate (7mm-27#)	1
188/2-539B	Shuttle driver (7mm)	1	188-517	Bent holder weighting	1
188/2-540	Ball connecting rod	1	167-4014	Synchronous belt wheel	1
188/2-541	Ball connecting rod	1	168/2-410-1	Screw	1
188/2-542	Connecting sleeve	1	168-4011	Washer	1
188/2-543	Bent holder	1	168-4012	Locking block	1
188/2-544	Hub of bent holder	1	168-4017	Cover of bent holder	1
188/2-545	Synchronous belt wheel	1	168-4019	Spacer	1
188/2-546	Washer	1	168-4045-1	Screw	1
188/2-547	Support of synchronous belt	1	268-918	End cover axle	2
188/2-548	Cover of gear	1	268-1037	Support	2
188/2-549 (168-4032)	Universal joint set	1	001	Bearing 7006AC	1
188/2-550	Support of synchronous belt wheel	1	002	Bearing CF10	1
188/2-551	Bearing baffle	1	003	Synchronous belt 5M×540×12	1
188/2-552 (168-4024, 61902)	Universal joint set	1	004	Synchronous belt T5×425×18	1
188/2-509A	Shuttle (6mm)	1	005	Hole ring Φ28	3
188/2-509B	Shuttle (7mm)	2	006	Bearing 61902	1
188/2-510	Internal shuttle stand	1	007	Roller bearing HK0709	1
188/2-511	Cover	1	008	Roller bearing HK0708	1
		1	009	Bearing 61804	1