



# GLOBAL

## ME SERIES

### Instruction & Parts manual

[www.globalsew.com](http://www.globalsew.com)

[info@globalsew.com](mailto:info@globalsew.com)





## FEATURES CHARACTERISTICAS :









The number of stitches per shell is changable simply by moving the one-touch lever on the frame cap and moving the edge guide simultaneously.

Any kinds of thread available, including woolen yarn.

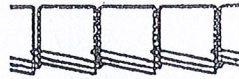
Suitable for light to heavy fabrics such as: sweater, dressing sacks, overcoats, robes, socks, blankets cushions, wherever a shellstitch on edge is appropriate, El numero de puntadas por pechina puede cambiarse moviendo simultaneamente la palanca de cambio y la quia del acabado de la pechina.

Puede trabajar con cualquier tipr de hilos, incluso con lanas.

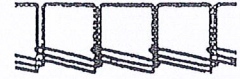
Para tejidos finos o gruesos, como jerseys, vestidos, abrigos, calcetines, tunicas, mantas, almohadillas, cualquier tipo de confeccion donde sea posible al puntada de pechina.

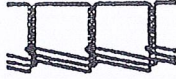
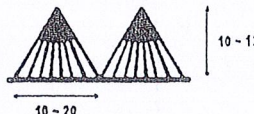
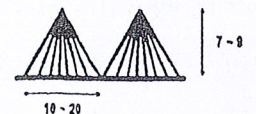
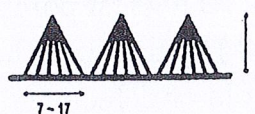
	MODEL MODELO		
	ME-38	ME-27	ME-17
Needle Aguja	DP×5 #18	DP×5 #18	DC×1 #19-21
Stitch forms Formas de puntada	1  4  8  	1  4  8  	3  6  
Shell size Dimensiones de la pechina ( mm )	Large Large 	Mediu Mediu 	Small Small 
Sewable thickness Grosor maxima del tejido	6 mm	5 mm	2.8 mm
Speed velocidad	1,200 s.p.m.	1,700 s.p.m.	1,900 s.p.m.



## 1. IMPORTANT

1. Before starting the machines, oil bearings of all moving parts.

2. Threading Machine See Fig. (#1 )

————— Indicates the sewing thread  
 - - - - - Indicates ornamental thread

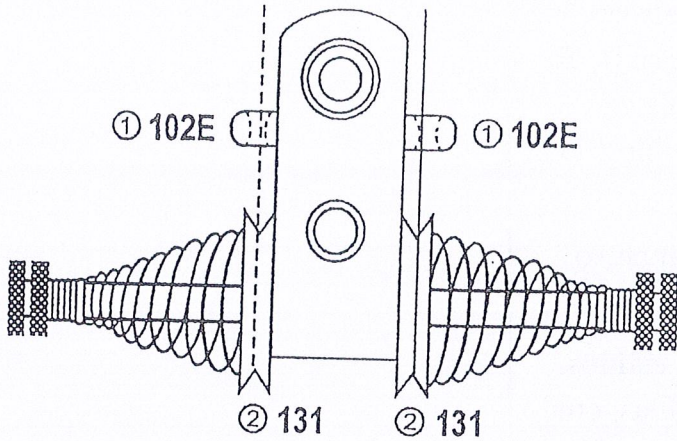

3. Hold the tale of the thread passed through the needle hole, and turn the hand pulley clockwise until the sewing thread is hooked by Latch Hook.

Repeat the same procedure mentioned above after the ornamental thread passes through the looper.

Pass ornamental thread through the thread guide (#102-A), instead of through guide (102-B) for sewing the thinner material, or more take-up stroke is required.

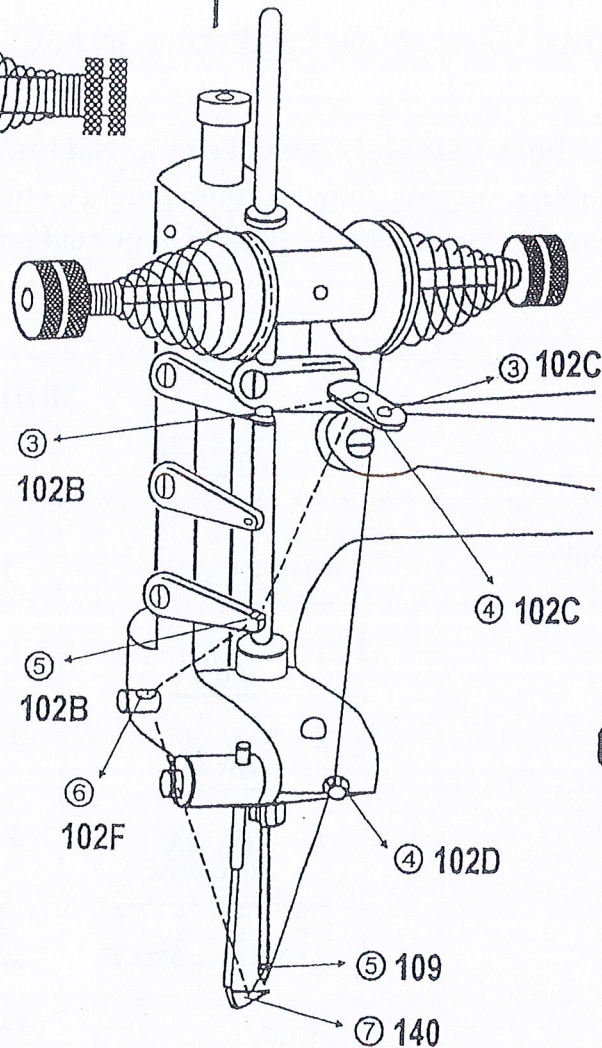

Fig #1

## 2. REPLACING NEEDLES

Turn the pulley away ( clockwise ) until the needle reaches in its highest point and loosen the needle clamp nut ( #108 ) by the wrench supplied as accessory to remove the old or defective needle.

Insert the new needle and tighten the needle clamp nut ( #108 ).

Always replace the old or defective needles.

They affect the satisfactory operation of the machine.



### 3. REPLACING LATCH NEEDLE

Turn the pulley until the Latch Needle comes under-neath the looper and loosen the set screw (#188) by the friver through the hole located in the Frame Cap (#184). By this, the Latch Needle can be removed by hand.

Insert the new Latch Needle until it reaches to the deepest point, but make it sure that the Latch Needle is not inserted twisted.

Should you find any excess play on the Latch Needle, adjust the position of the Latch Needle Carrier Guide (L-Shape) (#181) by loosening the Screws (#190), so that the L-shape Guide holds Latch Needle Carrier (#182) lightly. See Fig. #2.

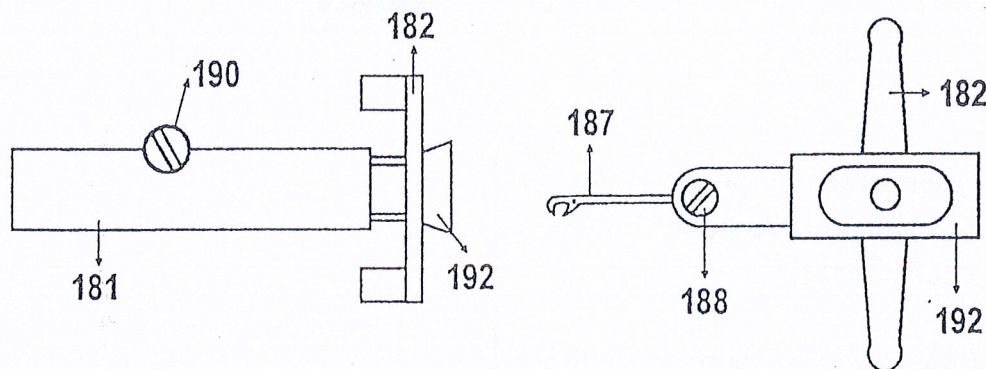

Fig #2

### 4. TIMING OF LOOPER

Looper serves the purpose to reinforce the seams made by sewing thread, always to ease the sewing thread to be hooked by the Latch Needle.

Accordingly, the looper timing is most important to obtain the satisfactory seams.

#### (a) Adjustment of the Looper Heights

Set the looper so that it will be positioned with the following clearance between the Latch Needles :

On Model ME-38

and ME-27 ..... 0.5 m/m

On Model ME-17..... 0.2 m/m

The above adjustments can be made by the Looper

Set Screw #144.

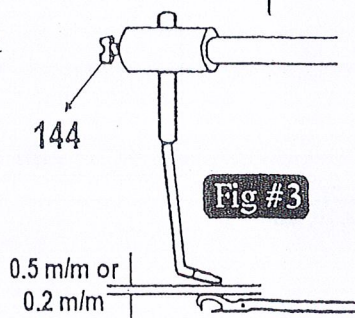

Fig #3



(b) Looper Toe is to be adjusted as shown by ( Fig. #3-a )

(c) Adjustment of the Looper Movement

This can be made by the cam slide set screw #143-S  
Set the looper, so that it comes to the closest position to the needle, when the needle goes up, but not touch to the needle.

Incorrect setting is the cause of the skip of seams and make it sure that this timing is properly set.

See. Fig. #4.

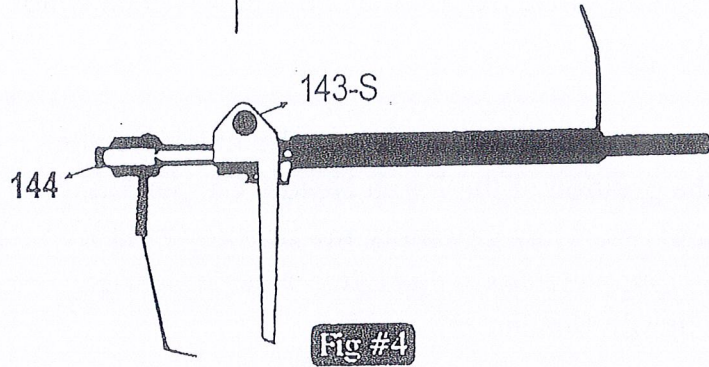
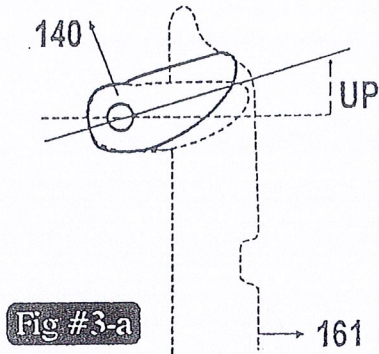

(d) Needle Guide (#206 ) serves the purpose not only to guard the needle in its correct position, but to open the Latch of Needle, occasionally.

Adjust the position of the thread guide by loosening the Needle Guard Bracket Screw #212 so that the top point of the Latch Needle comes to as close as to the Needle Guide, as shown in the Fig. #5.

The machine is equipped with the Needle Guaed, which accepts the Needle of sizes up to #22, in its standard model.

If the thicker needle will be used, replace the needle guard as well, which can be obtained at the special requirement.

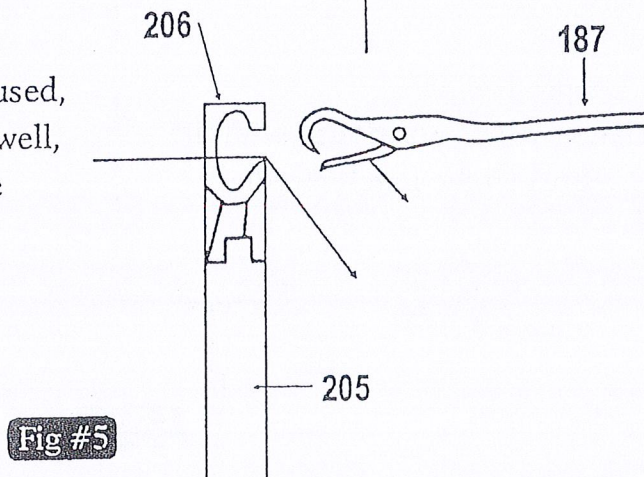



## 5. REPLACEMENT OF SEAM FORMING PLATE #161

Seam Forming Plate #161 serves a purpose of Chaining Fingers and is important for the satisfactory seam. Replace the plate whenever it is damaged by the needle.

Setting the different plate can be made as follows.

(a) On Models ME-38

Seam Forming Plate is desinged with the stopper in its right side edge and accordingly, set the plate by pulling the same to the fullest extent.

(b) On Models ME-27 and ME-17

The timing point is marked on the seam forming plate and the base cover and accordingly, set by these points. Fig. #6.

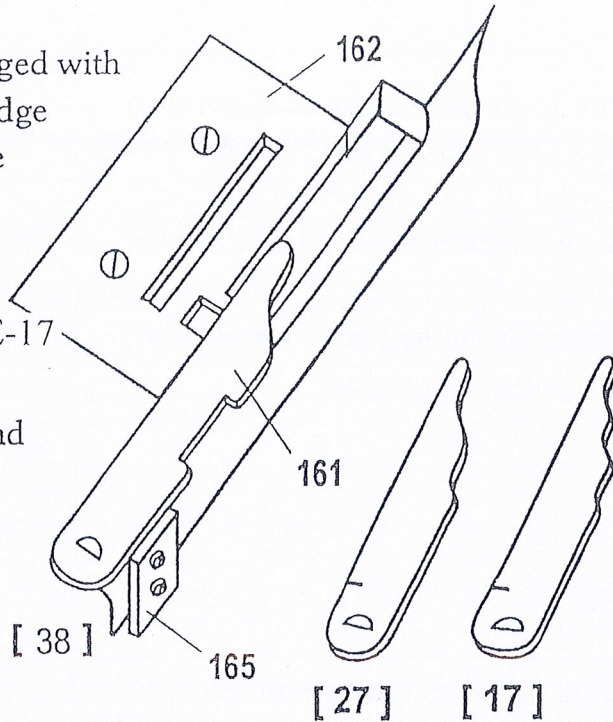

Fig #6

## 6. THREAD CARRIER

Thread Carrier (#177) serves the purpose that the sewing thread passes over the Latch of the Needle, as Well as to press down the ornamental thread through the looper.

Thread Carrier #177 should be set horizontally on Model ME-38, but a little slantly on Model ME-27' and quite slantly on Model ME-17. (See Fig. #7)

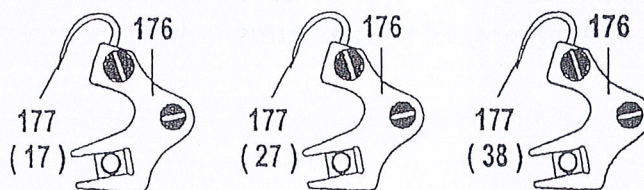

Fig #7

MJS-17

MJM-27

MJL-38



## 7. REMOVAL AND SETTING OF FRAME

### CAP.#184

#### ( a ) REMOVAL

First, remove the Latch Needle and remove the screws #190 on the Slide #271 and Guide #275.

Then loosen two screws #189 and #184 to remove the Frame Cap by pulling out.

#### ( b ) SETTING

While trying to put the cover plate in its position, turn the pulley in both ways (rear and forward ) with manual slight adjustment, so that the two rollers on the latch needle carrier will meet the cam groove, then push the cover forward.

It is suggested that you remove the latch needle beforehand, whenever you start this procedure.

## 8. CHANGE LEVER

On Models ME-38 and ME-27 , the different numbers of stitches per shell can be obtained by the stitch number adjusting lever. Press the Ratchet #274 for the change to the different stitch number.

On Model ME-17 this lever is not equipped and the change of the stitch number can be obtained by the cam (#203-22 ) attached to the feed gear (#200-22 ).

Application of two cams (as shown in the parts catalog) forms four stitch shells and by removing one side cam, the machine forms 8 stitch shells.

On Model ME-17, the arrangement is similar to Model HF-22, but with the different cam ( #203-17 ) and gear (#200-17 ). Stitch number is six per shell by two cams and 3 stitches by one cam.



## 9. ADJUSTING THE FEED VOLUME AND SEAM WIDTH

### (a) Feed Volume

Open the side cover and move the Feed Connecting Rod #251 for adjustment, by loosening the nut #254. (Fig. #8.)

### (b) Seam width can be adjusted but very slightly by the seam guide #275. ( Fig. #8-a )

On Model ME-38 ..... 10 m/m to 12 m/m

On Model ME-27 ..... 7 m/m to 9 m/m

On Model ME-17 ..... 5 m/m to 6 m/m

### (c) Heights of the Feed Lever # 261 can be adjusted by the adjuster #259, located on the Feed Bar Bracker #257.

By moving the adjuster #259 to the left side, higher position of the feed is obtained and is good for heavier material.

Movement to the right side, lower the heights of the feed dog and is good for thinner material. (Fig. #9)

Higher Position for Heavier Material.

Lower Position for Thinner Material.

Fig #8

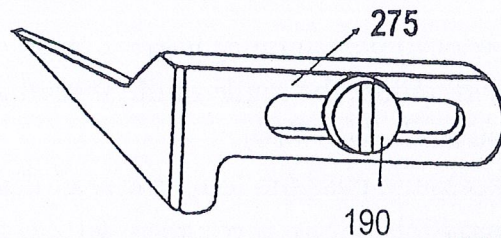
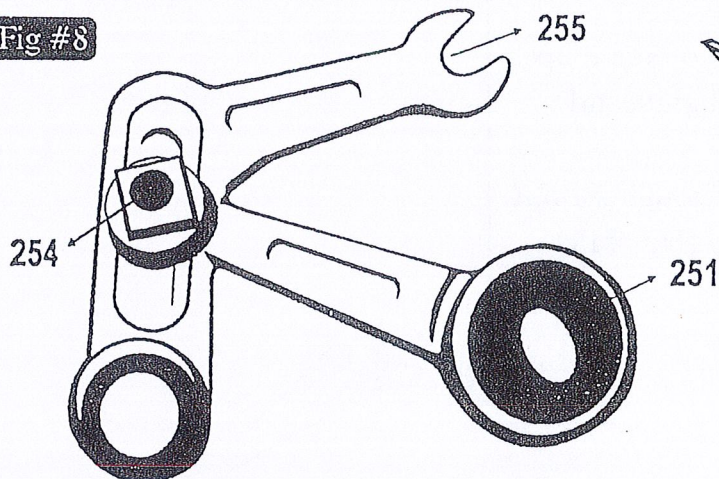

Fig #8-a

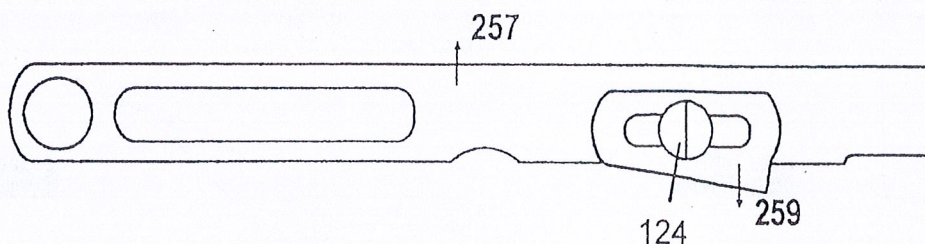

Fig #9



## 10. SUGGESTIONS

COBALT Clam-shape stitch Machine produces the different sizes and taste shell stitches by the application of the different kinds of clothes, thread and yarn.

In order to obtain the better shell stitches, the followings are suggested :

- (a) Make the tension of Loper Thread or Yarn always a little loose.
- (b) For using the synthetic stretchable thread. loosen the tension of the looper thread, and also make the tension of the sewing thread tighter.
- (c) for stretchable materials, make the tension of the looper thread tight to prevent the stretch of the material itself.

Model ME-27 is recommended for sewing extremely strechable materials.

Kinds of Thread and Yarns to be used for the Large shell stitch :

For Model ME-38 ~ (Large size Shell stitch)

Wool and synthetic

For Model ME-27 ~ ( Medium size shell stitch )

wool and synthetic

For Model ME-17 ~ ( small size shell stitch )

Cotton and tetlon.

(d) In order to obtain more loose tension on the looper thread, adjust the angle of the thread guide, ad illustrated. (Fig. #10)

(e) If necessary, pass the looper thread through #102A after #102B before through to #102C.(Fig. #11)

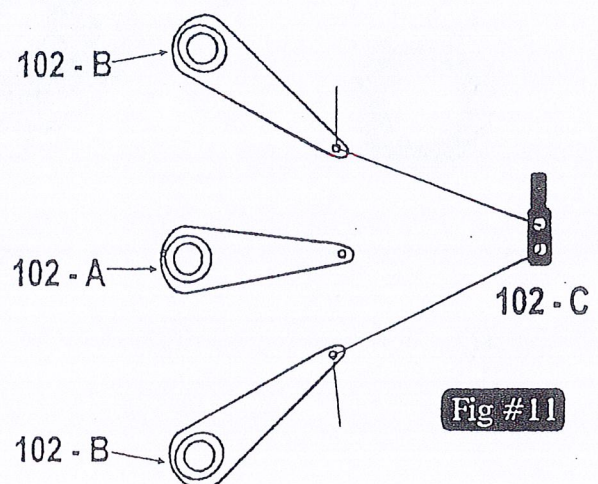
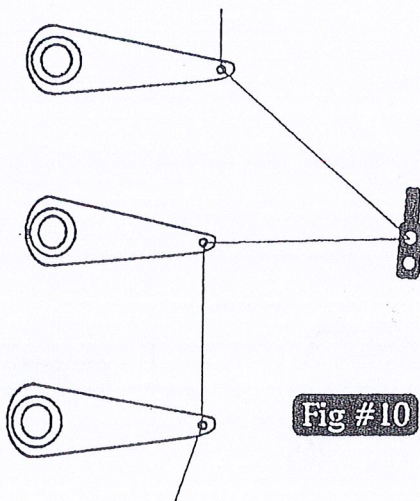



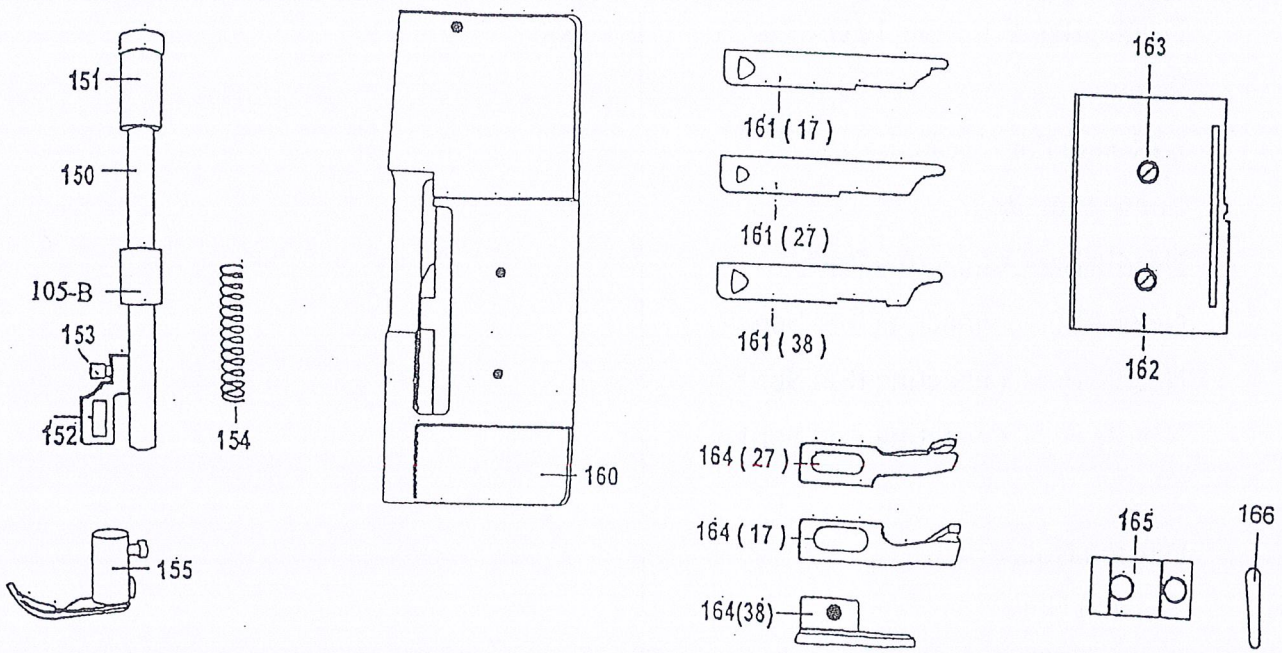
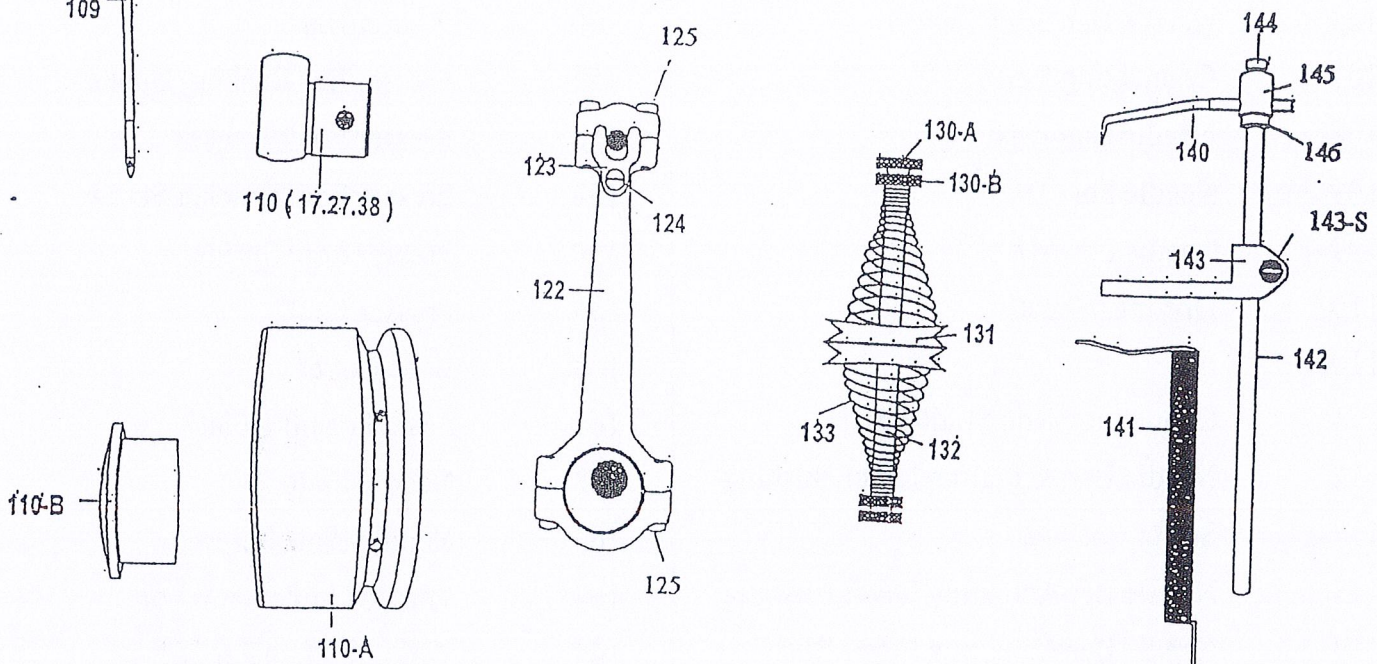
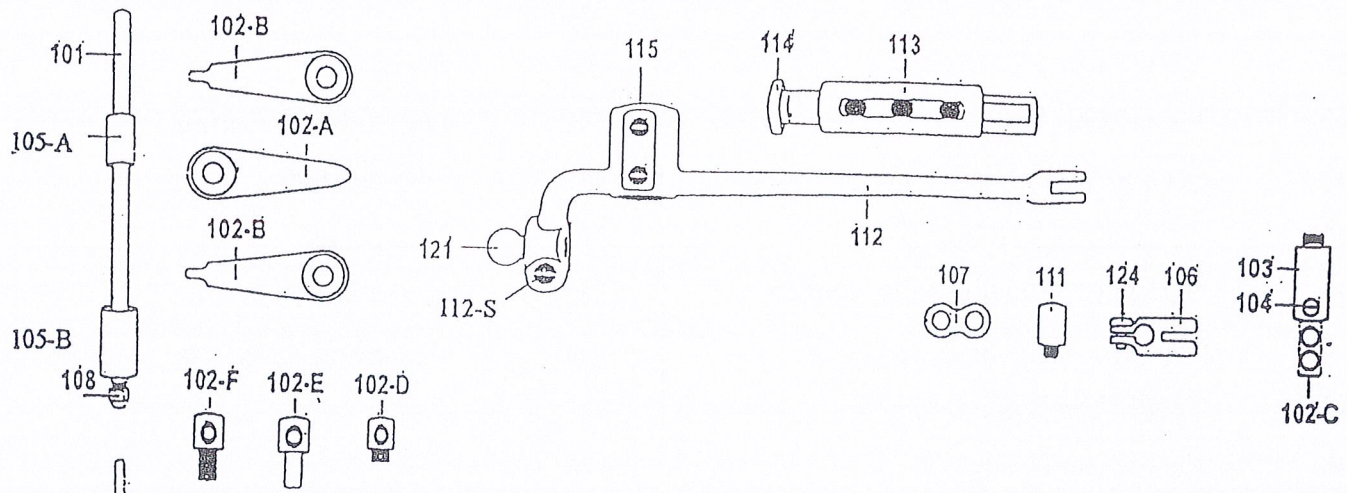



101	Needle Bar	140	Looper
102A-F	Thread Guides	141	Looper Shaft Spring
103	Set Screw For Thread Guide 102-c	142	Looper Shaft
104	Connecting Rod Stud(Large)	143	Cam Slide
105	Needle Bar Bushing(also serve As Presser Bar Bushing Lower)	143-s	Screw For 143
157	Needle Bar Bushing Screw	144	Cam Slide Set Screw
106	Needle Bar Guide	145	
124	Needle Bar Guide Screw	146	
107	Connecting Rod	150	Presser Bar
108	Needle Clamp Nut	151	Presser Bar Bushing Upper
109-38	Needle For ME-38	152	Presser Foot Bracket
109-17	Needle For ME-17	153	Presser Foot Bracket Screw
110A	Driving Wheel	154	Presser Foot Spring
110B		155	Presser Foot
111	Connection Rod Stud(Small)	160	Bade Cover
112	Needle Bar Actuating Lever Bushing	161	Seam Forming Plate
112-s	Screw For 112	162	Neddle Plate
113	Needle Bar Actuating Lever Bushing	163	Neddle Plate Screw
114	Needle Bar Actuating Lever Rod	164	Thread Guide Shim For
115	Needle Bar Acurating Lever Rod Screw	165	Pressure Plate For 161
121	Ball Stud For Needle Bar Connecting Rod	166	
122	Needle Bar Connecting Rod		
125	Needle Bar Connecting Rod Screw		
123	Needle Bar Connecting Rod Spring		
124	Needle Bar Connecting Rod Spring Screw		
130-A	Tension Nut A		
130-B	Tension Nut B		
131	Tension Plate		
132	Tension Stud		
133	Tension Spring		



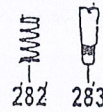
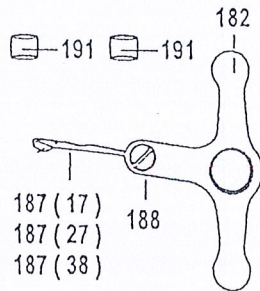
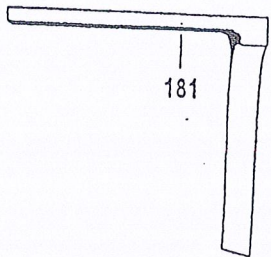
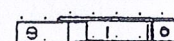
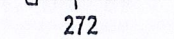
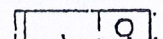
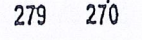
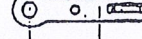
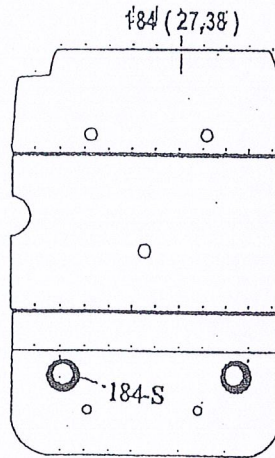
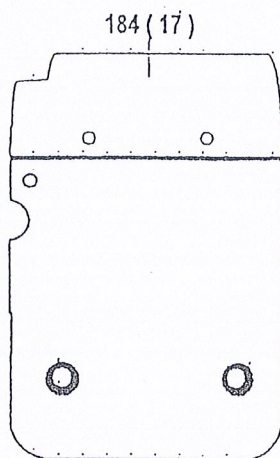
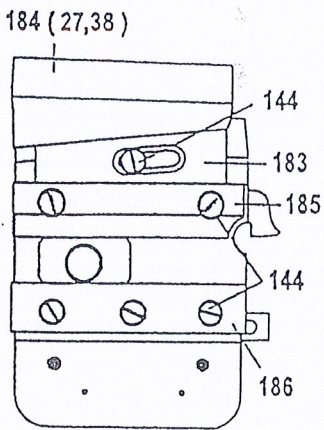
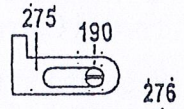
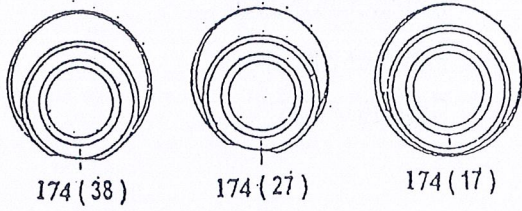
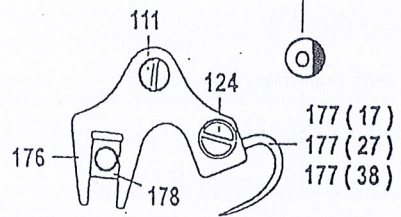
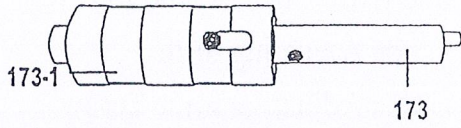
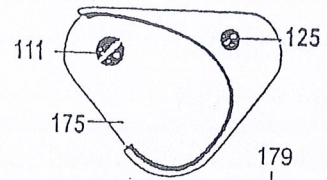
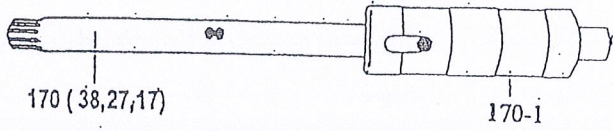
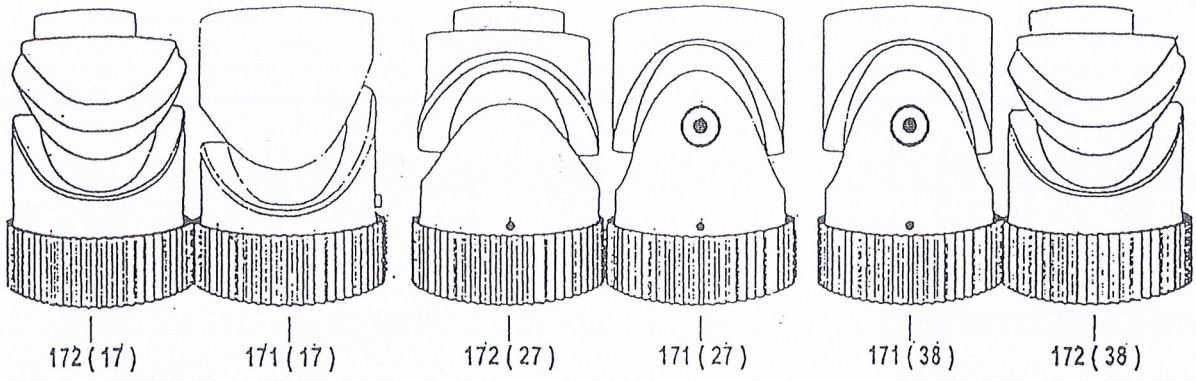



171-38	Lower Cam For ME-38	277	Connecting Bar For 270 And 271
172-38	Upper Cam For ME-38	280	Screw For 277
171-27	Lower Cam For ME-27	270	Stitch Number Adjusting Lever
171-27	Upper Cam For ME-27	279	Stitch Number Adjusting Lever Screw
171-17	Lower Cam For ME-17	271	Stitch Number Adjusting Lever Slide
172-17	Upper Cam For ME-17	272	Connecting Slide For Feed Lifting Lever
170	Main Shaft	190	Set Screw For 271 And 272
173	Upper Shaft	273	Guide Adjusting Slide
174	Feed Eccentric	278	Guide Adjusting Slide Screw
175	Cover Plate For Thread Carrier Assembly	274	Ratchet For 270
125	Set Screw For 175	282	Ratchet Spring
111	Pivot Screw	283	Stud For 274
176	Thread Carrier Bracket		
177	Thread Carrier		
124	Thread Carrier Screw		
179	Feed Eccentric Screw		
178	Slide Guide		
181	Latch Needle Carrier Guide (L-Shape)		
183	Lib Key		
144	Screw For 183		
184	Frame Cap		
189	Frame Cap Screw		
185	Upper Gib		
186	Lower Gib		
144	Gib Screw		
182	Latch Needle Carrier		
187-38	Latch Needle For ME-38		
187-17	Latch Needle For ME-17		
188	Latch Needle For Set Screw		
191	Cam Roll		
275	Guide (Seam Width)		
190	Guide Screw		
276	Stitch Number Indicator		
281	Stitch Number Indicator Screw		



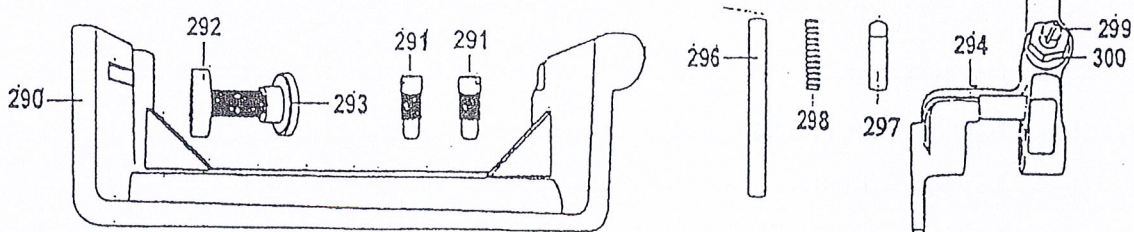
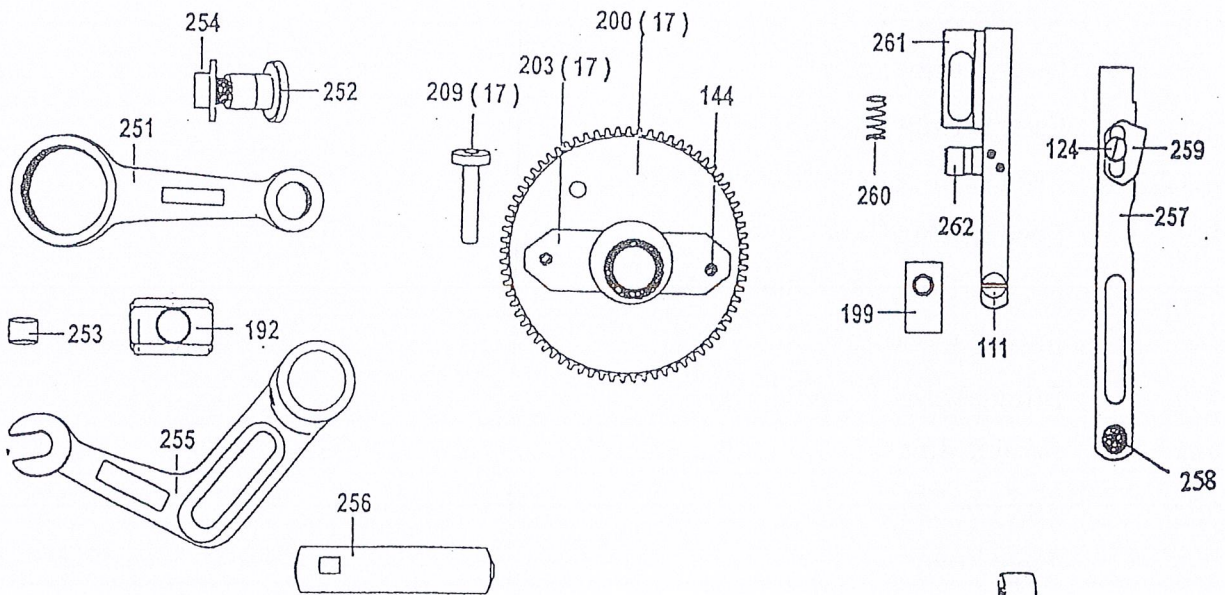
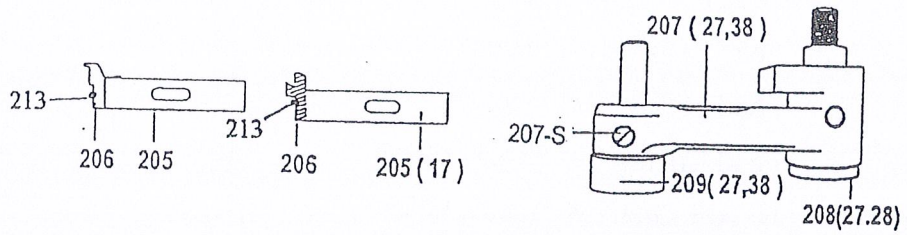
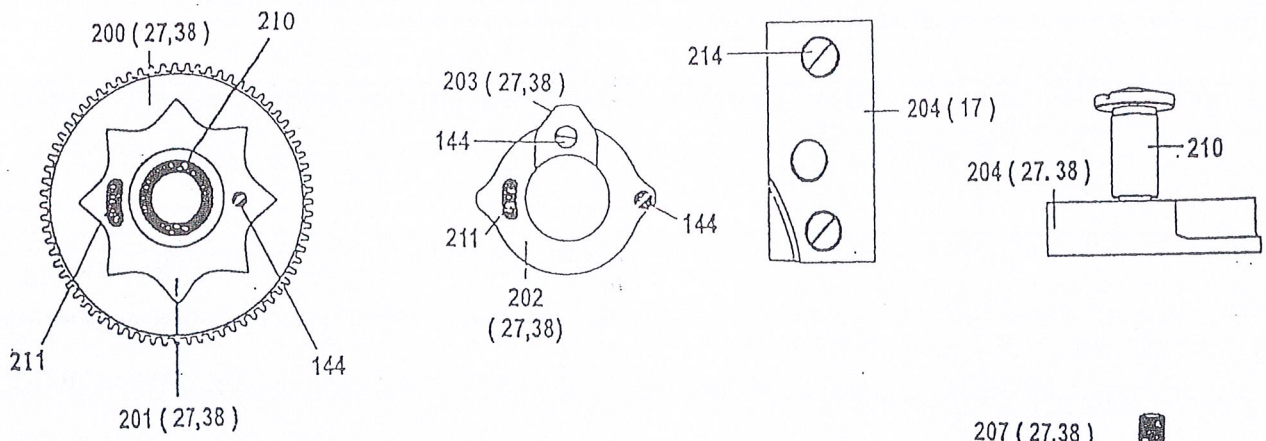



200-27,38	Feed Lifting Gear For ME-38 And ME-27	144	Screw For 165
201	Feed Lifting Cam (1 stitch)	290	Side Cover
144	Feed Lifting Cam Screw	291	Side Cover Screw
202	Feed Lifting Cam (4 stitch)	292	Side Cover Stopper
211	Feed Lifting Cam Screw	293	Stopper Knob
203-27,38	Feed Lifting Cam (8 stitch)	294	Presser Foot Lift Assembly
144	Feed Lifting Cam Screw	297	Presser Foot Lift Assembly
204-27,38	Feed Lifting Gear Bracket	298	Presser Foot Lift Assembly
214	Feed Lifting Gear Bracket Set Screw	299	Presser Foot Lift Assembly
210	Feed Lifting Fear Rocker Screw	300	Presser Foot Lift Assembly
206	Needle Guard & Needle Guard Bracket		
213	Needle Guard Screw		
207-27,38	Feed Lifting Lever		
207-s	Feed Lifting Lever Screw		
208-27,38	Feed Lifting Lever Rockr Screw		
209	Feed Lifting Cam Guide		
188	Feed Lifting Cam Guide Screw		
251	Feed Conecting Rod		
252	Stitch Adjusting Stud		
253	Feed Roller		
254	Nut For 252		
255	Feed Lever		
192	Latch Needle Carrier Block		
256	Feed Lever Stud		
257	Feed Bar Bracket		
258	Feed Bar Bracker Rocker Screw		
259	Feed Lifting Adjuster		
124	Feed Lifting Adjuster Screw		
260	Feed Bar Bracker Pressing Spring		
261	Feed And Feed Bar		
111	Feed And Feed Bar Screw		
262	Subsidiary Feed		
199	Feed Bar Stopper For ME-38 And ME-27		



ME-18

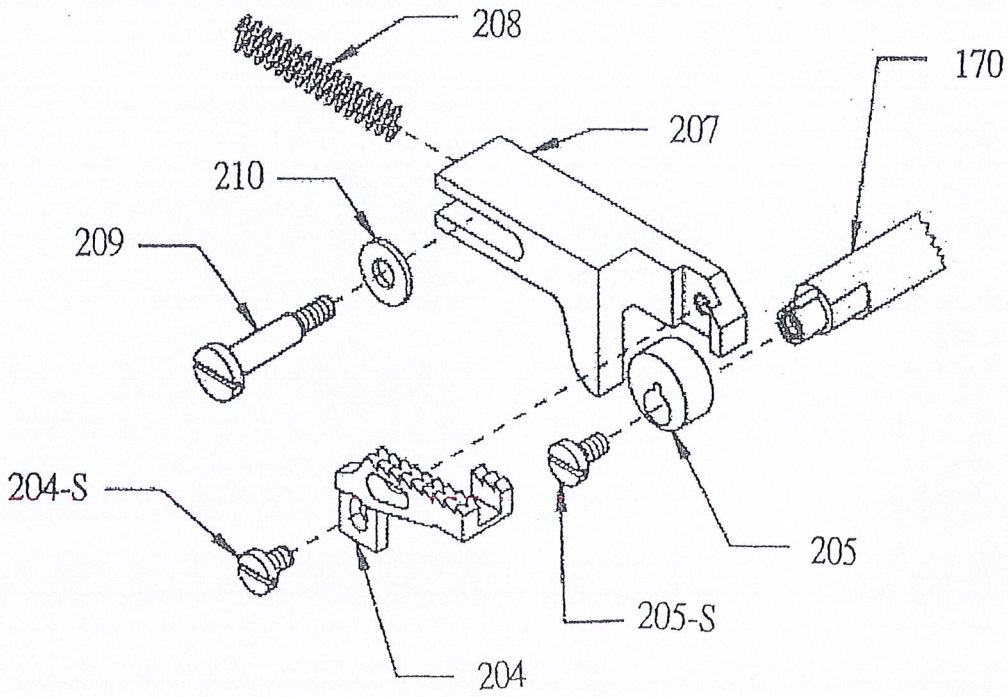
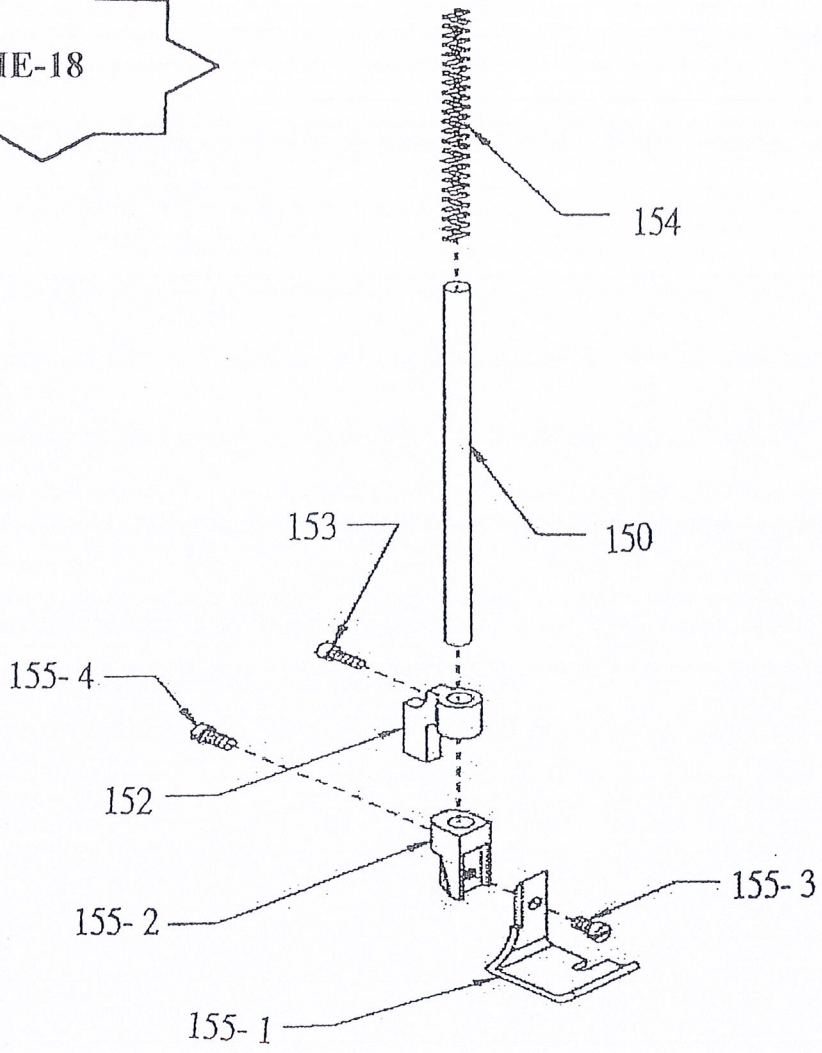



ME-18

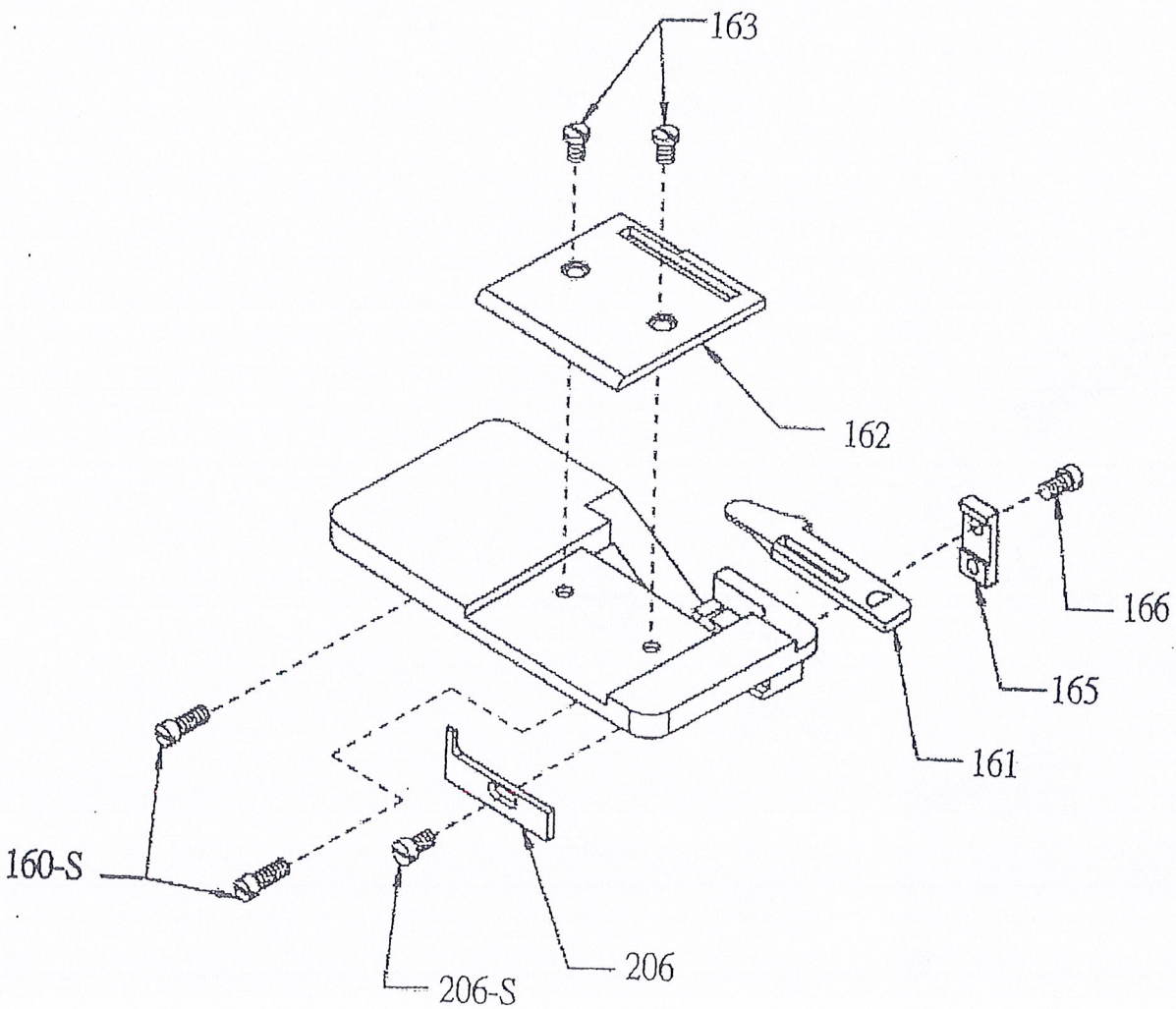
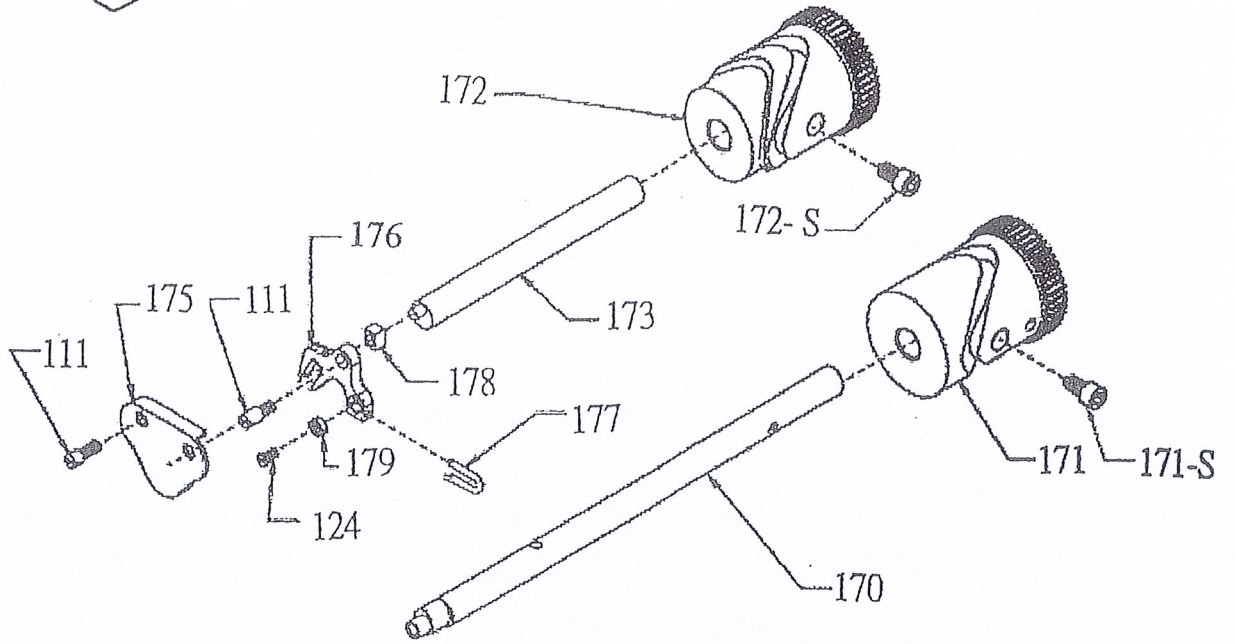







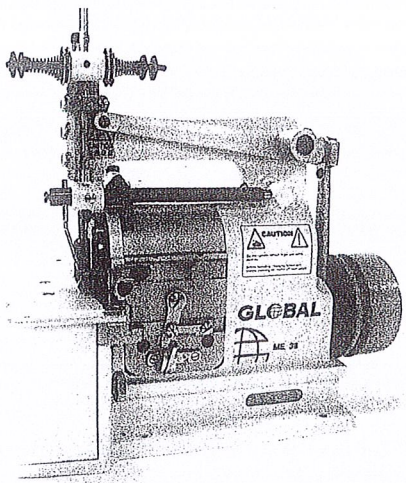

# GLOBAL® ME SERIES

## Plain crochet and Shell stitch crochet machines

**ME 17** – Small size shell stitch machine, suitable for light to heavy fabrics such as sweater, overcoats, socks, blankets, wherever a shellstitch is appropriate. The number of stitches per shell can be changed by changing cam attached on the feed gear ( 3 or 6 stitches per shell). The required part is supplied standard with the machine.

**ME 18** – Plain chrochet machine for hemming and edging blankets and other knit and woven fabrics.

**ME 27** – Medium size shell stitch machine, suitable for light to heavy fabrics such as sweater, overcoats, socks, blankets, wherever a shellstitch is appropriate. The number of stitches per shell is changeable by moving the one – touch lever on the frame cap and moving the edge guide ( 4 or 8 stitches pro shell). It is possible to produce plain crochet stitches with this machine.

**ME 38** – Large size shell stitch machine, suitable for light to heavy fabrics such as sweater, overcoats, socks, blankets, wherever a shellstitch is appropriate. The number of stitches per shell is changeable by moving the one – touch lever on the frame cap and moving the edge guide ( 4 or 8 stitches pro shell). It is possible to produce plain crochet stitches with this machine.

Model	Width (mm) Seam/shell	Stitch length (mm)	Stitches p/minute	Sewing thickness	Needle system	Latch needle
ME 17	6 mm	7-17 mm	1500 s/pm	2,8 mm		187 - 17
ME 18	10 mm	2,5 – 6 mm	1200 s/pm	7,0 mm		187 - 18
ME 27	7 – 9 mm	10 – 20 mm	1200 s/pm	5,0 mm		187 - 27
ME 38	10 – 12 mm	10 – 20 mm	1200 s/pm	6,0 mm		187 – 38



frontside



backside

Edging stitch of ME - Series 27 & 38

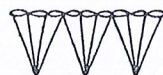

4 stitches



8 stitches

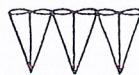

3 stitches



6 stitches

Shell stitch of ME – Series 17, 27 & 38



frontside



backside