

# GLOBAL

Our experience. Your success

## LP 8970 I SERIES

MANUAL



## 1. Safety

### 1.01 Safety symbols



Danger!  
Points to be observed



Danger of injury for operating and specialist personnel!

#### Caution

Do not operate without finger guard and safety devices.  
Before threading, changing bobbin and needle, cleaning etc. switch off main switch.

### 1.02 Important points for the user

- This Instruction Manual is a component of the machine and must be available to the operating personnel at all times.
- The Instruction Manual must be read before operating the machine for the first time.
- The operating and specialist personnel must be instructed in the safeguards of the machine and safe work methods.
- It is the duty of the user to operate the machine in perfect running order.
- It is the obligation of the user to ensure that none of the safety mechanisms are removed or deactivated.
- It is the obligation of the user to ensure that only authorized persons operate and work on the machine.

# Safety

---

1.03

## Danger



A working area of 1 meter is to be kept free both in front of and behind the machine in operation so that the machine is always easily accessible.



Never reach into the sewing area while sewing! Danger of injury by the needle!



Never leave objects on the table while adjusting the machine settings! Objects can become trapped or be slung away! Danger of injury!



Do not operate the machine without support 1! Danger due to top-heavy sewing head! Machine can tip over backwards when tilted!

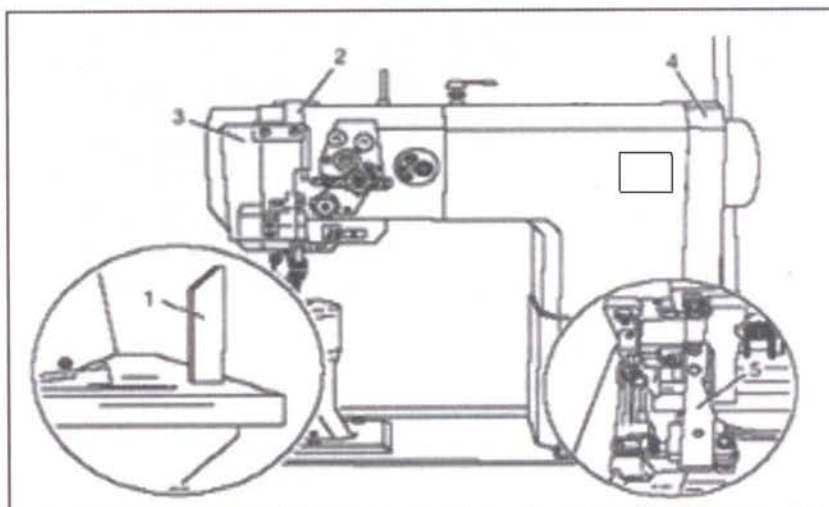



Switch the machine off before tilting it backwards!  
Danger of injury if the machine is started accidentally!



Do not operate the machine without its take-up-lever guard **2!**  
Danger of injury due to the motion of the take-up lever!



On machines with thread lubricator, only operate the machine with the eye guard **3** lowered! The eye guard **3** protects the eyes from oil particles from the thread lubrication!



Do not operate the machine without belt guard **4!**  
Danger of injury by rotating drive belt!



Do not operate the machine without tilt lock **5!**  
Danger of crushing between sewing head and table top!

# Specifications

---

2

## Specifications

Stitch type.....301(lockstitch)

Stitch length

Singl needle.....1.3-7mm

Double needle.....1.3-4.8mm

Clearance under roller presser.....7mm

Clearance width.....245mm

Clearance height.....115mm

Post heighe.....180mm

Sewing head dimensions

length.....approx.615mm

Width.....approx.240mm

Height(above table).....approx.500mm

Bedplate dimensions.....518x177mm

Max.speed

Singl needle.....2500spm

Double needle.....2000spm

Connection data

Operating voltage.....230V ± 10%, 50/60Hz

Max.power consumption.....1.2KVA

Net weight of sewing head.....approx.61kg

Gross weight of sewing head.....approx.71kg

Subject to alteration

Model

LP 8971

LP 8974

## 3 Controls

### 3.01 Pedal

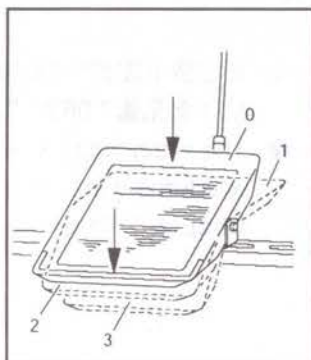

0= Neutral position

1= Sewing

2= Raiser roller presser

3= Trim sewing threads (on machines with-D..)

### 3.02 Lever for lifting roller presser

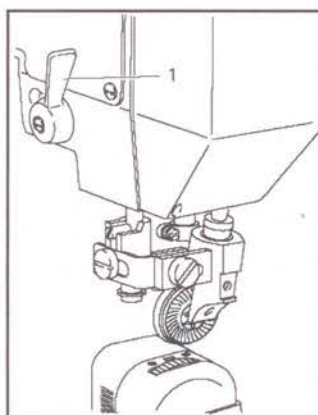

- The roller presser can be raised by turning lever 1.

### 3.03 Knee lever

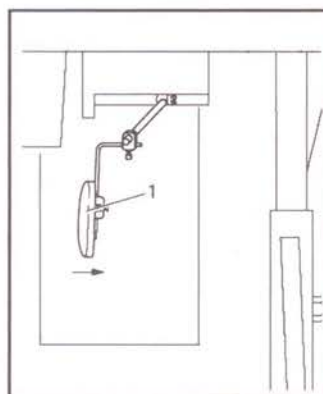

- The roller presser can be raised by pressing the knee lever 1 in the direction of the arrow.

# Controls

---

## 3.04 Key for setting stitch length

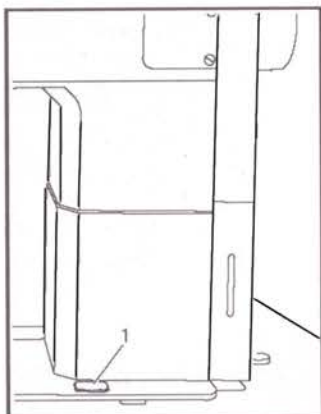

- The stitch length is set by pressing key 1 and turning the balance wheel.

## 3.05 Swing out roller presser

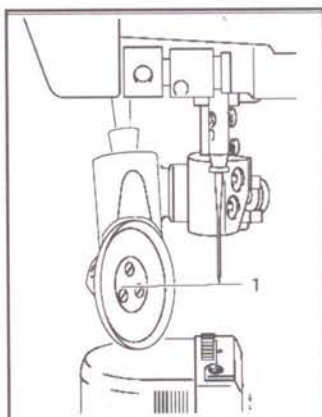

- When the roller presser is raised, it can be swung out by pulling it lightly downwards.

# Installation and commissioning

---

## 4 Installation and commissioning



The machine must only be installed and commissioned by qualified personnel!  
All relevant safety regulations must be strictly adhered to!



If the machine is delivered without a table, be sure to use a stand and table top that can hold the weight of the machine with its motor.  
It is very important to ensure that the stand of the machine is firm and steady, also during sewing.

### 4.01 Installation

The site where the machine is installed must be provided with suitable connections for electric current.  
It must be ensured that the standing surface of the machine site is firm and horizontal, and that sufficient lighting is provided for.



For packing and transportation reasons the table top is in the lowered position. The table height is adjusted as described below.

### Adjusting the table height

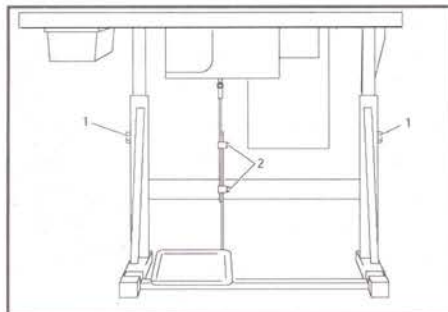

- Loosen screws **1** and **2** and set the table height as required.
- Firmly tighten screw **1**.
- Set the required pedal position and tighten screw **2**.



# Installation and commissioning

---

## 4.02 Fitting the reel stand

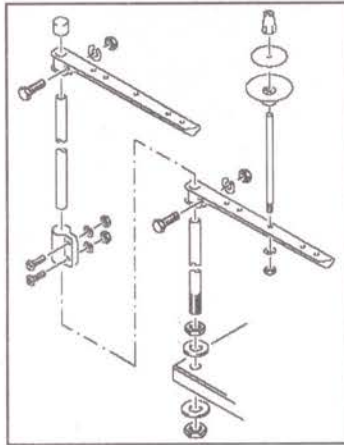

- Fit the reel stand as shown in Fig.
- Afterwards insert the stand in the hole of the table top and secure it with the nuts provided.

### 4.02.01 Fitting the tilt lock

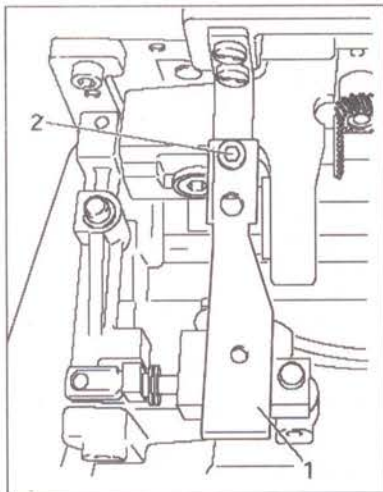

Maschine ausschalten!  
Verletzungsgefahr durch unbeabsichtigtes Anlaufen der Maschine!

- Die im zubehör befindliche kipp-sicherung1 mit schraube 2 anschrauben.



Maschine nicht ohne kipp-sicherung 1 betreiben! Sicherung 1 betreiben!  
Quetschgefahr zwischen oberteil und tischplatte!

# Installation and commissioning

---

## 4.03 Commissioning

- Check the machine, particularly the electrical wiring for any damage.
- Clean the machine thoroughly and then oil it or fill oil in.
- Have a mechanic check whether the motor of the machine can be operated with the available power supply, and that the motor is correctly connected in the junction box. If there are any discrepancies, the machine **must not be operated under any circumstances**.



The machine only be connected to an earthed socket!

- When the machine is running, the balance wheel must turn towards the operator. If it does not, the motor connection must be changed by a mechanic.
- Machines with pneumatic equipment must be connected to the compressed air supply. The pressure gauge should indicate a pressure of 6 bar. If necessary, adjust to the correct setting (see **Chapter 6.01 Checking adjusting the air pressure**).

## 4.04 Tilted work base

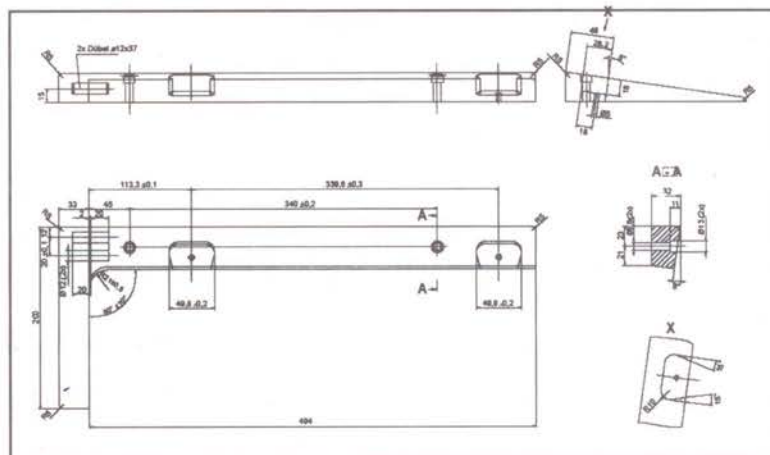

# Installation and commissioning

## 4.05 Tilted work base

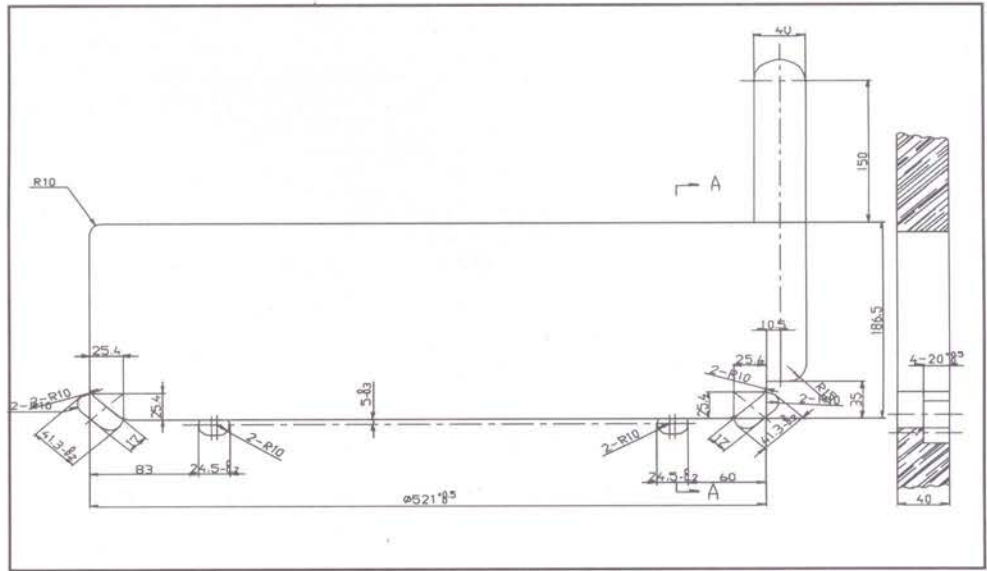

## 4.06 Mounting the table top

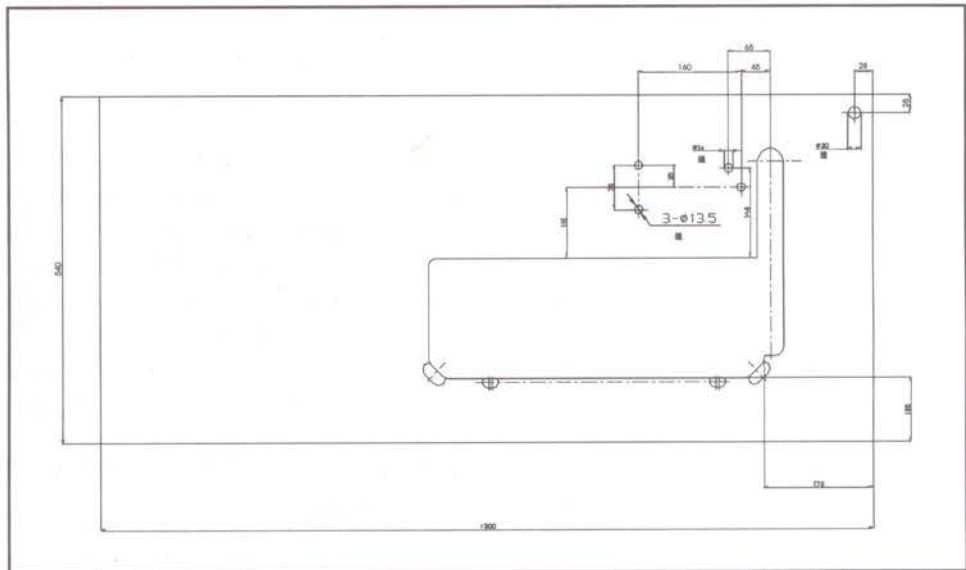

5

## Preparation



All instructions and regulations in this Instruction Manual must be observed .

Special attention must be paid to all safety regulations!



All setting-up work must only be carried out by personnel with the appropriate training. For all setting-up work the machine must be disconnected from its power supply by turning off the on/off switch, or removing the plug from the electric power socket.

5.01

### Inserting needle on model



Switch the machine off! Danger of injury if the machine is started accidentally!

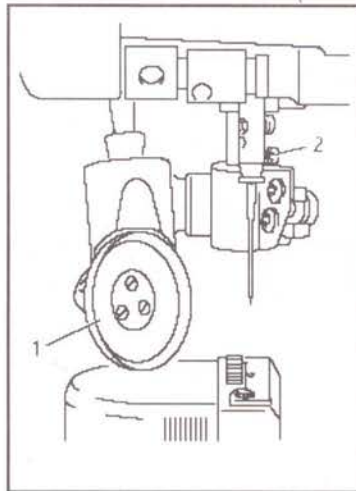

Only use needles of system 134

- Raise the roller presser 1 and swing it out
- Loosen screw 2 and insert the needles . as far as possible. The long groove must face to the **left** on model LP 8971
- Tighten screw 2 and swing roller presser 1 back to position.



The Choice of needle depends on the model of the machine and the thread and material used .

# Preparation

---

## 5.02 Winding the bobbin thread; adjusting the primary thread tension



- Place an empty bobbin **1** into bobbin winder spindle **2**.
- Thread the bobbin as shown in **Fig.** And wind it clockwise around bobbin **1** a few times
- Switch on the bobbin winder while pressing bobbin winder spindle **2** and lever **3**.



The bobbin is filled up during sewing.

- The thread tension of bobbin **1** can be adjusted by knurled screw **4**.
- The bobbin winder stops automatically when bobbin **1** is full.

If the thread is wound unevenly:

- Loosen nut **5**.
- Turn thread guide **6** accordingly.
- Tighten nut **5**.

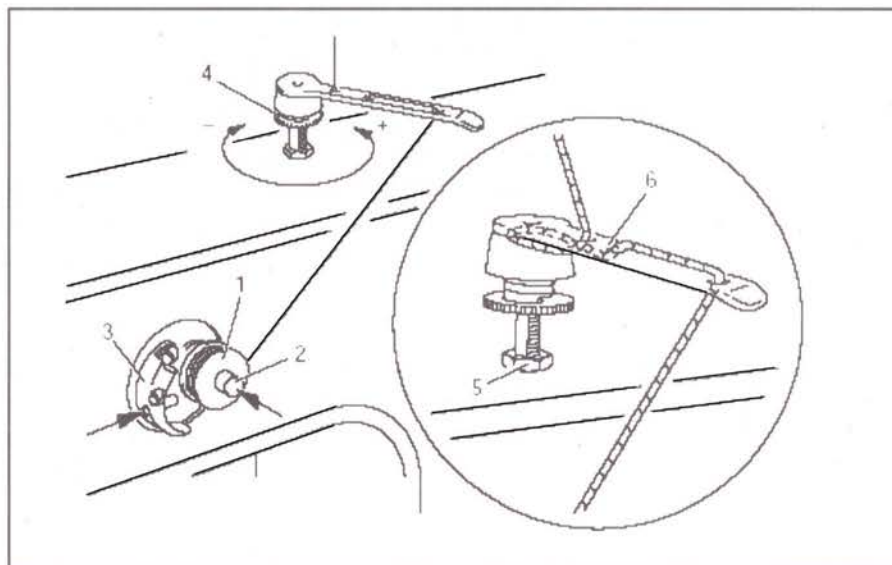

## 5.03 Removing/Inserting the bobbin case

Switch the machine off! Danger of injury if the machine is started accidentally!

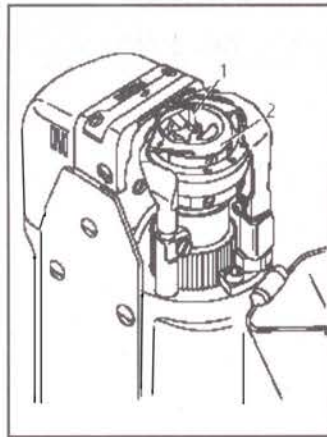

Removing the bobbin case:

- Open the post cap.
- Raise latch 1 and remove bobbin case 2.

Inserting bobbin case:

- Insert bobbin case 2.
- Close the latch and close the post

## 5.04 Threading the bobbin case/Adjusting the bobbin thread tension

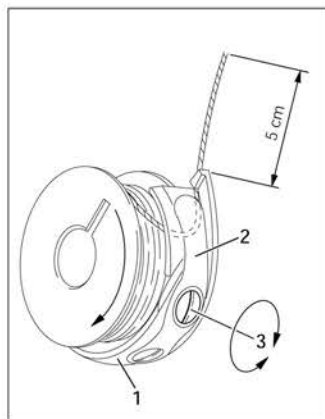

- Insert the bobbin into the bobbin case 1.
- Pass the thread through the slot under spring 2.
- Pass the thread through the notch.
- Adjust the thread tension by turning screw 3.



When the thread is pulled, the bobbin must rotate in the direction of the arrow.

# Preparation

---

## 5.05 Threading the needle thread and regulating its tension on model LP 8971



Switch the machine off!  
Danger of injury if the machine is started accidentally!



- Tilt up the eye guard 1.
- Thread the needle thread as shown in **Fig.**
- Adjust the needle thread tension by turning milled screw 2.

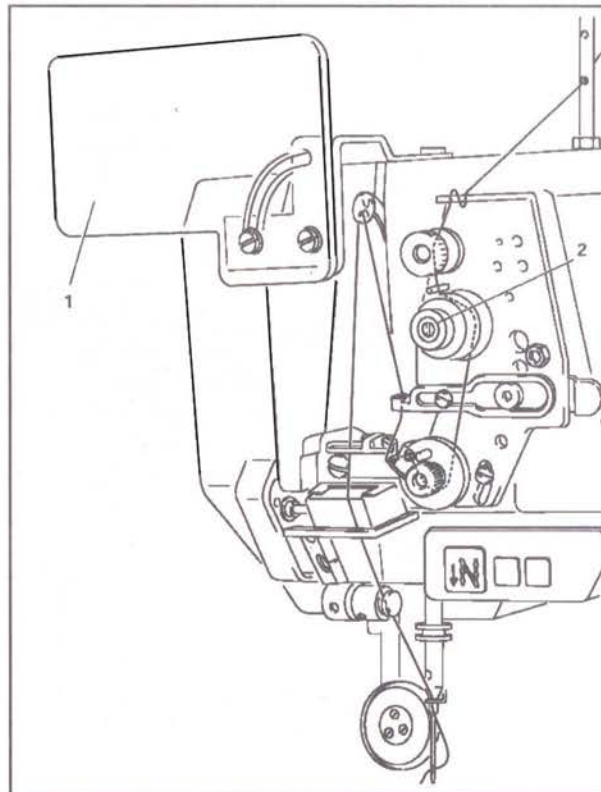

## 5.06 Setting the stitch length



- Press key 1 and at the same time turn the balance wheel until the stitch setter clicks into position.
- Hold down key 1 and turn the balance wheel to and fro until the stitch length required is shown on the scale 2 opposite the bottom edge 3 of the belt guard recess.

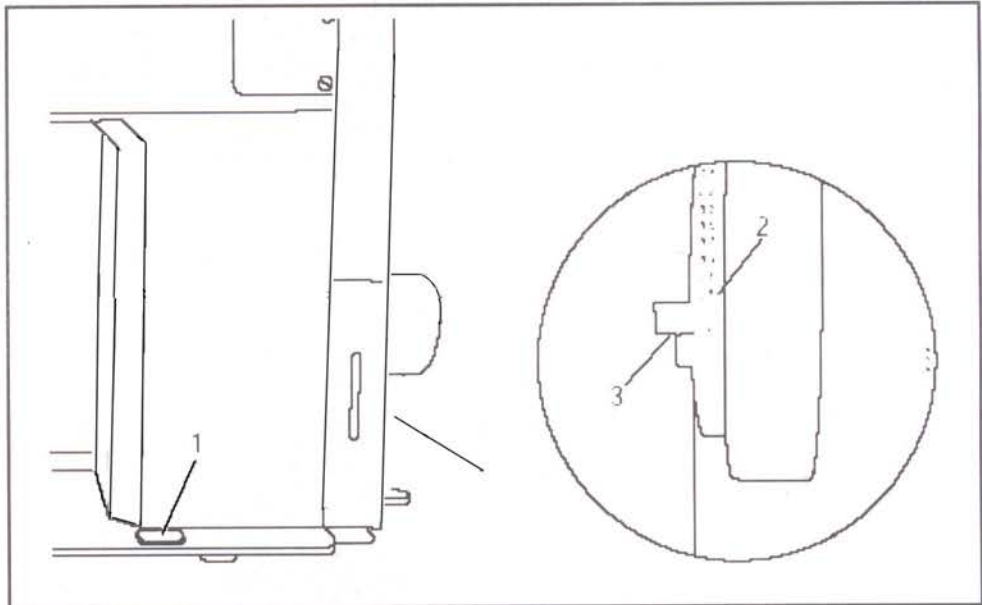



# Care and Maintenance

---

## 6 Care and Maintenance

Clean.....	daily, more frequently if in continuous operation
Oil level (thread lubrication/hook lubrication) .....	daily, before use
Oil the hook.....	daily, before use
Lubricate the bevel gears.....	once a year
Check/adjust air pressure.....	daily, before use
Clean air filter of air filter/lubricator.....	when required



These maintenance intervals are calculated for the average running time of a single shift operation. If the machine is operated more than this, shorter intervals are recommended.

### 6.01 Checking and adjusting the air pressure (on the pneumatic machine)

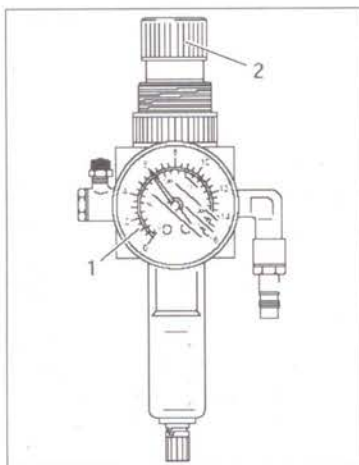

- Before operating the machine, always check the air pressure on gauge 1.
- Gauge 1 must show a pressure of **6 bar**.
- If necessary adjust to this reading.
- To do so, pull knob 2 upwards and turn it so that the gauge shows a pressure of **6 bar**.

# Care and Maintenance

---

## 6.02 Clean the air filter of the air-filter/lubricator (on the pneumatic machine)



Switch the machine off!  
Disconnect the air hose at the air-filter/lubricator.

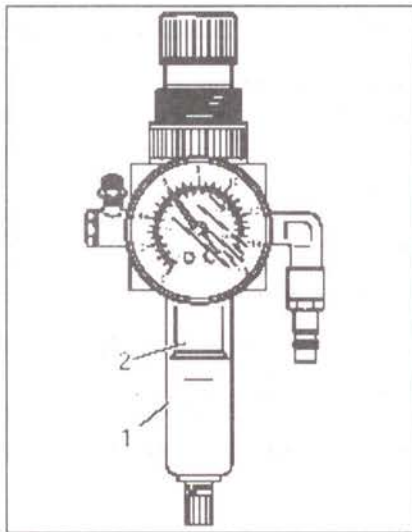

Draining water bowl 1:

- Water bowl 1 drains itself automatically when the compressed-air hose is disconnected from the air-filter/lubricator.

Cleaning filter 2:

- Unscrew water bowl 1.
- Take out filter 2.
- Clean filter 2 with compressed air or isopropyl alcohol.
- Screw in filter 2 and screw on water bowl 1.

## 6.03 Cleaning

Clean the hook, hook compartment and toothed wheel 3 every day, several times if in continuous use

Switch the machine off!  
Danger of injury if the machine is started accidentally!

# Care and Maintenance

---

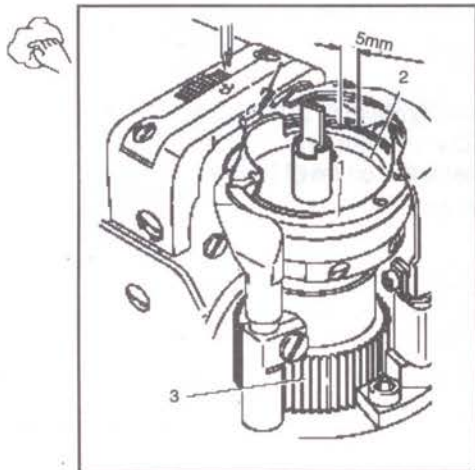

- Bring the needle bar to its highest position.
- Open the post cap and remove the bobbin case cap and the bobbin.
- Unscrew hook gib 1.
- Turn the hand wheel until the point of bobbin case 2 penetrates into the groove of the hook race approx. 5mm.
- Remove bobbin case 2.
- Clean the hook race with paraffin.
- When inserting the bobbin case 2, ensure that the horn of the bobbin case 2 engages in the groove of the needle plate.
- Screw hook gib 1 back on and close the post cap.

## 6.04 Oiling the hook



Switch the machine off!  
Danger of injury if the machine is started accidentally!

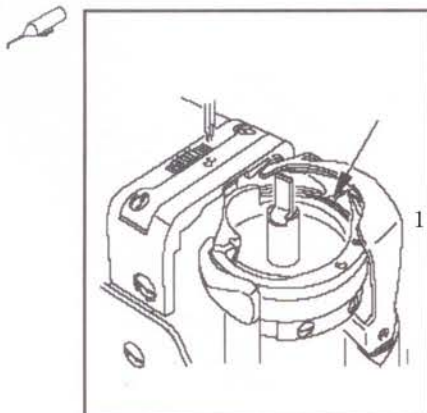

- Pour 1-2 drops of oil into hole 1 of the hook gib daily.
- Before commissioning the machine, and after long periods out of operation, pour a few drops of oil into the hook race (see arrow).

## 6.05 Oil bowl for hook lubrication

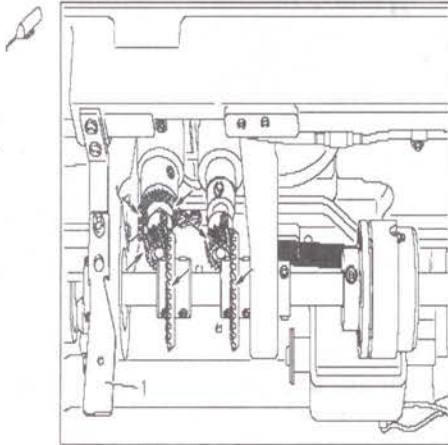

⚠ Check the oil level before each use. There must always be oil in reservoir 1.

If required refill oil through hole.

⚠ Use only oil with a mean viscosity of  $22.0\text{mm}^2/\text{s}$  at  $40^\circ\text{C}$  and a density of  $0.865\text{g}/\text{cm}^3$  at  $15^\circ\text{C}$ .



## 6.06 Filling the oil reservoir of the thread lubrication unit



Control the oil level before each use.  
There must always be oil in the reservoir 1.

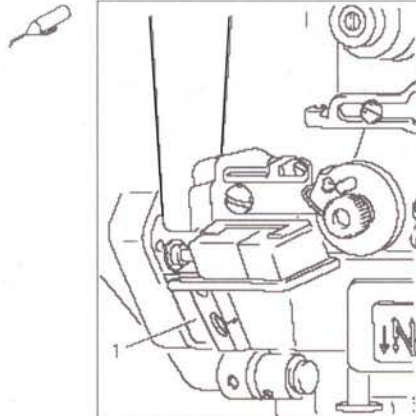

● If necessary, fill oil up to mark through hole

We recommend thread lubricating oil .

# Care and Maintenance

---

## 6.07 Lubricating the bevel gears

Switch the machine off!  
Danger of injury if the machine is started accidentally!

- All bevel gears must be supplied with new grease once a year.
- Tilt the sewing head back onto the support.



Fig. shows the bevel gears of the

- Apply grease to all the tooth flanks and the rack (see arrows).
- To set the sewing head upright, press tilt lock 1 backwards and set the sewing head upright using both hands.



Use both hands to set the sewing head upright!  
Danger of crushing between the sewing head and the table top!



We recommend sodium grease with a dripping point of approx. 150C.

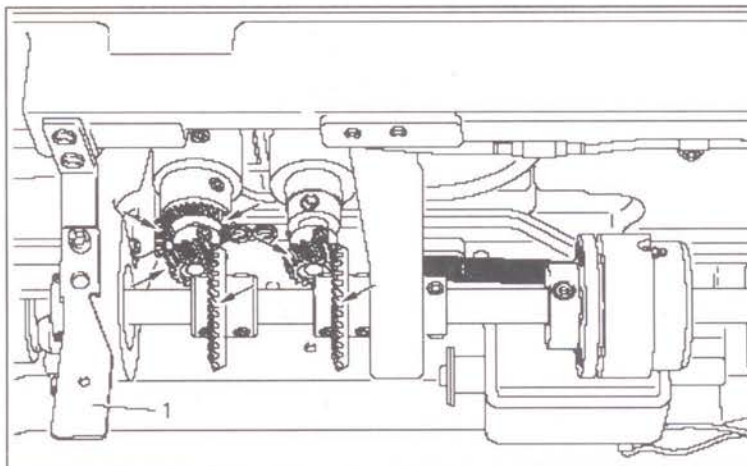

## 7 Adjustment



Unless stated otherwise, during all adjustment work the machine must be disconnected from electric and pneumatic power supply!  
Danger of injury if the machine is started accidentally!

### 7.01 Notes on adjustment

- All following adjustment are based on a fully assembled machine and may only be carried out by expert staff trained for this purpose.
- Machine covers, which have to be removed and replaced to carry out checks and adjustments, are not mentioned in the text.
- The order of the following chapters corresponds to the most logical work sequence for machines which have to be completely adjusted. If only specific individual work steps are carried out, both the preceding and following chapters must be observed.
- Screws, nuts indicated in brackets ( ) are fastenings for machine parts, which must be loosened before adjustment and tightened again afterwards.

### 7.02 Tools, gauges and other accessories

- 1 set of screwdrivers with blade widths from 2 to 10 mm
- 1 set of open ended wrenches with opening sizes from 7 to 13 mm
- 1 set of allen keys from 1.5 to 6mm
- 1 clamp
- 1 metal ruler
- 1 gauge
- Sewing thread and test material

# Adjustment

---

## 7.03 Adjusting the basic machine

### 7.03.01 Needle position in sewing direction on the LP 8971

#### Requirement

With the stitch length set at its minimum, the needle should be positioned in the centre of the needle hole, as seen in the direction of sewing.



- Set the minimum stitch length.
- Adjust needle bar (screw 1) according to the **Requirement**.

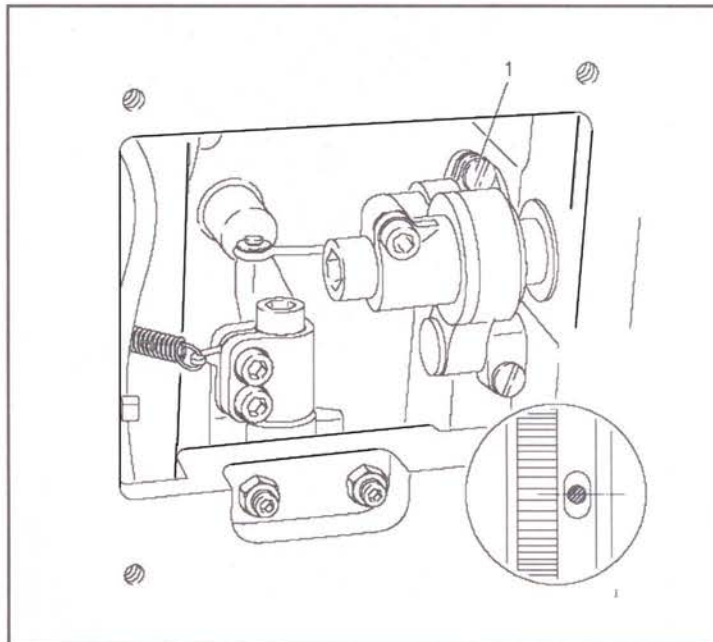

## 7.03.02 Preliminary adjustment of the needle height

### Requirement

When the needle bar is at top dead centre, there must be a clearance of approx. 21 mm between the needle point and the needle plate.



- Adjust needle bar 1 (screw 2). Without turning it, according to the Requirement.

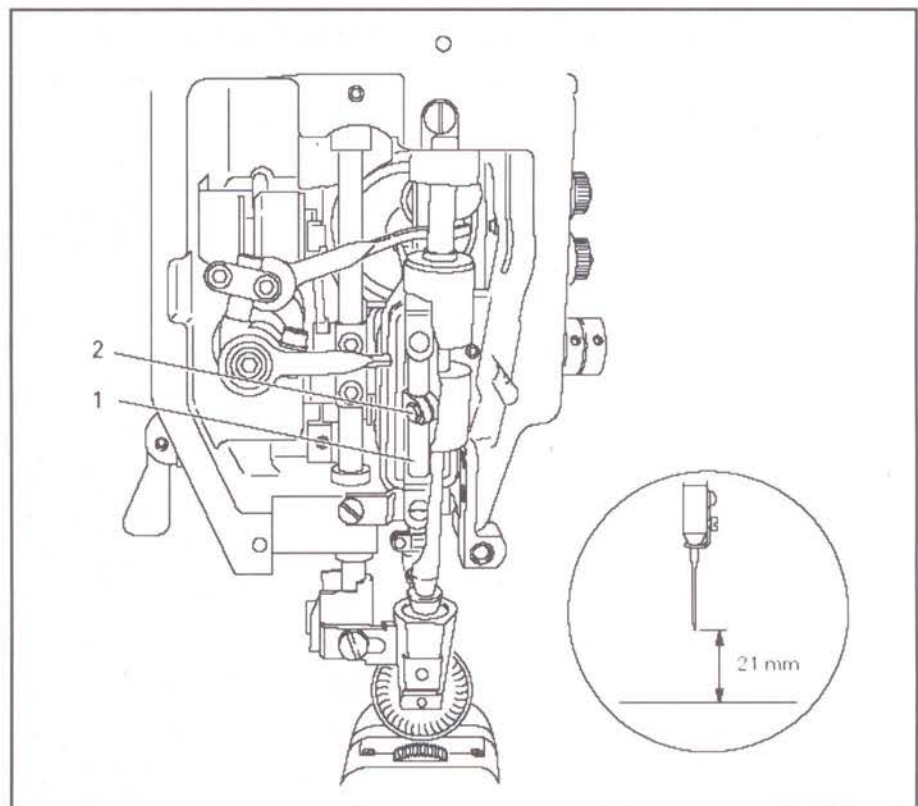



# Adjustment

## 7.03.03 Needle rise, hook clearance, needle height and needle guard on the LP 8971

### Requirement

With the needle bar positioned **2.0mm** after bottom dead centre and the stitch length set at "**0.8**" :

1. the hook point must be at needle centre with a hook-to-needle clearance of **0.05 to 0.1mm**.
2. the top of the needle eye must be **0.8 to 1.0 mm** below the hook point.
3. The needle guard **6** must touch the needle lightly.

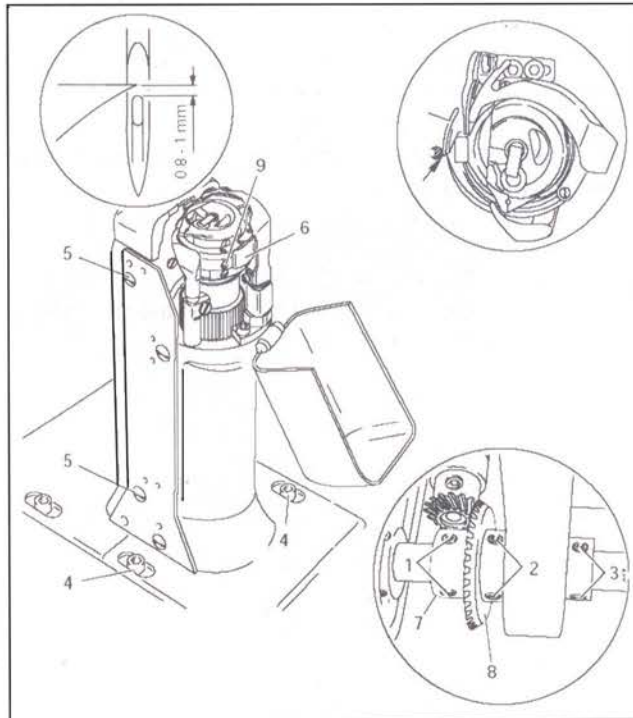

# Adjustment

---



- Loosen screw 1, 2, 3, 4 and 5.
- Bring needle bar to **2.0 mm** past bottom dead centre.
- Set hook point at needle centre, making sure that the needle is not deflected by needle guard 6.
- Adjust needle height according to **Requirement 2**.
- Adjust hook post according to **Requirement 1** and tighten screw 4.
- Making sure that there is some play in the bevel gear, tighten screws 2.
- With retaining collar 7 touching bevel gear 8 tighten screws 1.
- Adjust needle guard 6 (screw 9) according to **Requirement 3**.



When the hook is changed, make sure that the markings **10** and **11** are both on one side.

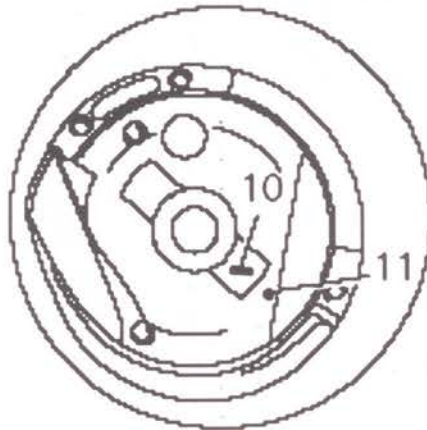

# Adjustment

---

## 7.03.04 Needle position crosswise to sewing direction on the LP 8971

### Requirement

As seen crosswise to the sewing direction, the needle must penetrate in the centre of the needle hole.



- Adjust feed wheel post 1 (screws 2, 3 and 4) according to the Requirement.

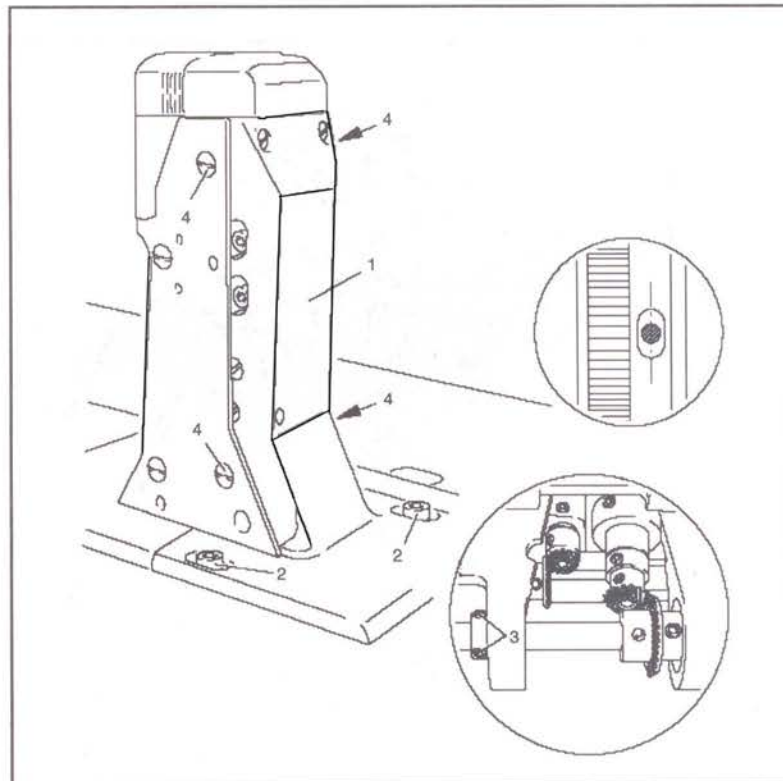

## 7.03.05 Height and stroke of the bobbin case opener

### Requirement

1. The top edges of the bobbin case opener **1** and bobbin case **3** should be on one level.
2. when the bobbin case opener **1** has deflected the bobbin case to its furthest point, the catch of the bobbin case should be from **0.3** to **0.5** mm from the back edge of the needle plate recess.



- Adjust bobbin case opener **1** (screw **2**) in accordance with **Requirement 1**.
- Turn the balance wheel until the bobbin case opener has deflected the bobbin case to its furthest point.
- Adjust bobbin case opener **1** (screw **2**) in accordance with **Requirement 2**.

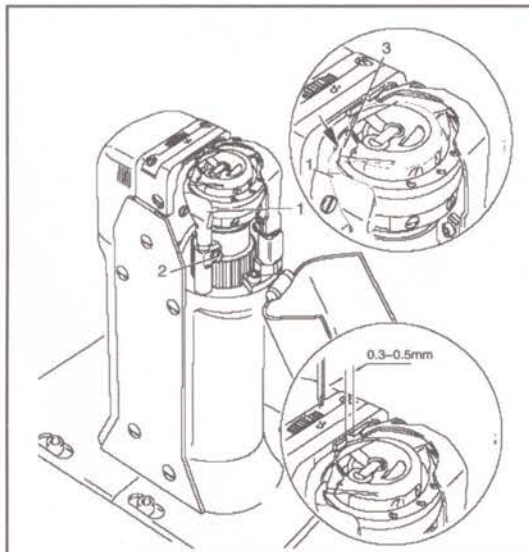

On the LP 8974 these adjustments must be repeated on the right post. Depending on the thread size, a variation of the setting in Requirement 2 is permitted.

# Adjustment

---

## 7.03.06 Height of the feed wheel on the LP 8974

### Requirement

1. when pressure is applied to the feed wheel **4**, it should protrude from the needle plate by tooth height (approx. **0.8 mm**).
2. when no pressure is applied to the feed wheel **4**, it should have a vertical play of approx. **0.3 mm**.



- Swing out the roller presser
- Loosen screws **1** and **2** (two screws each).
- Adjust drive wheel **3** according to **Requirement 1**, taking care to see that the teeth of drive wheel **3** and feed wheel **4** lock into each other properly.
- Tighten screws **1**.
- Adjust guide **5** according to **Requirement 2** and tighten screws **2**.

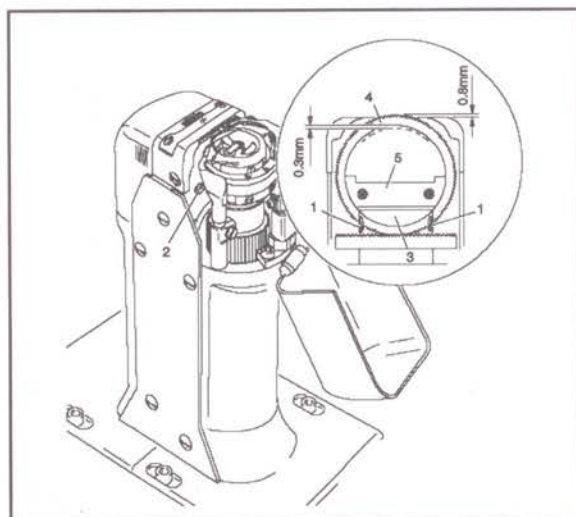

## 7.03.07 Height of the feed wheel on the

### Requirement

Feed wheel should protrude from the needle plate by tooth height (appro. **0.8 mm**).



- Swing out the roller presser
- Loosen screws 1.
- Adjust eccentric 3 (fastening screw accessible through hole 2) according.
- Tighten screws 1.

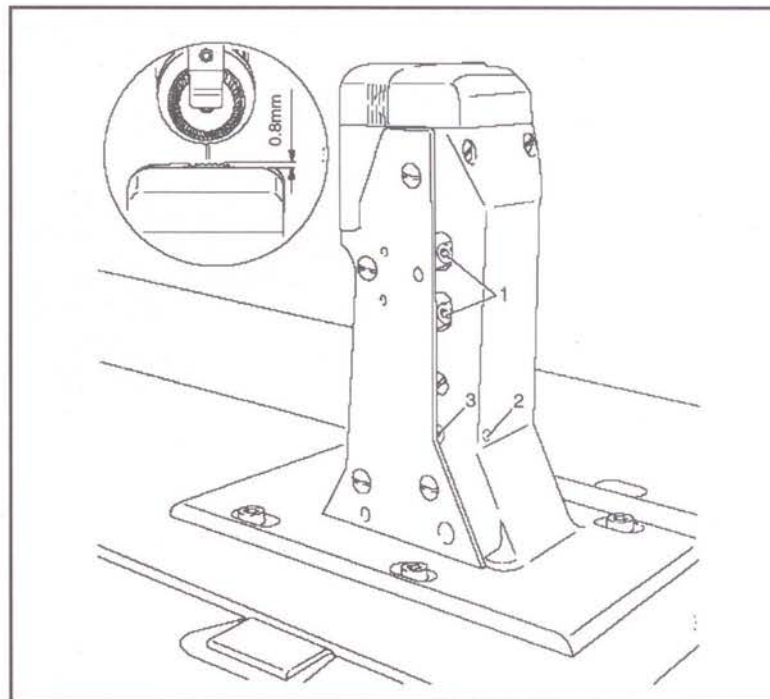

# Adjustment

---

## 7.03.08 Stitch length control eccentric

### Requirement

When the needle (with maximum stitch length set), coming from top dead centre, is **3 mm** above the needle plate, the crank **3** must have reached its front point of reversal.



- Set the maximum stitch length.
- Turn stitch length control device **1** (screws **2**) according to **Requirement**.

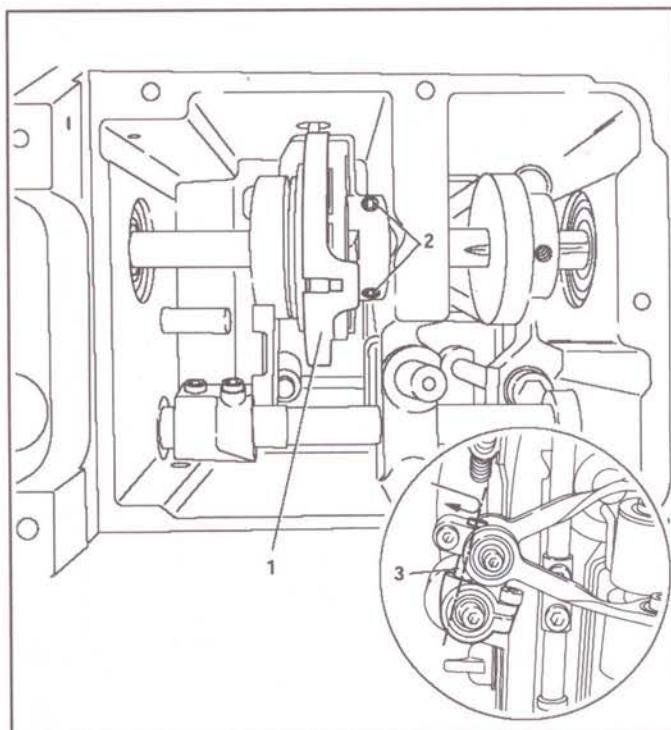

## 7.03.09 Stitch length scale disk

### Requirement

When the stitch length control device is locked in position, and the maximum stitch length is set, the marking line of the highest number on the scale disk **1** must be opposite the lower edge **3** of the belt guard recess.



- Set the maximum stitch length.
- Turn the scale disk **1** according to the **Requirement**.

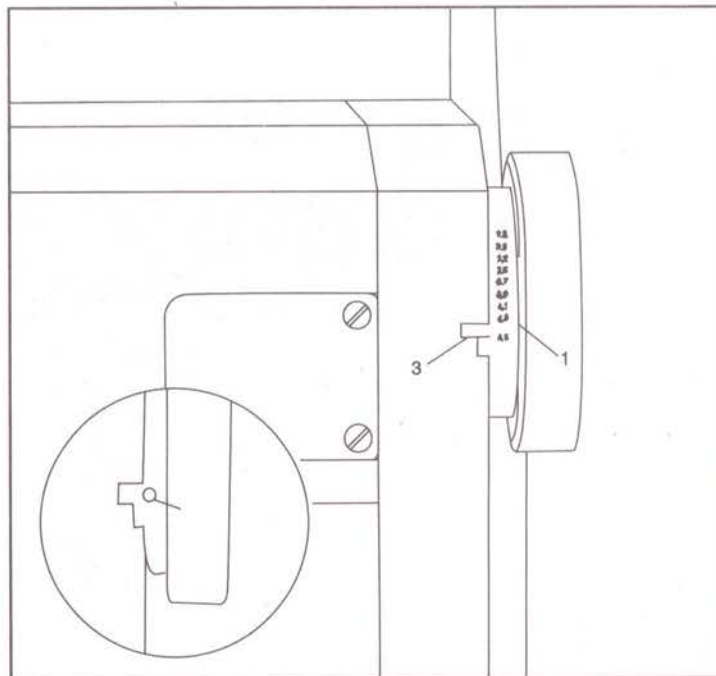



# Adjustment

---

## 7.03.10 Shaft crank to feed wheel drive

### Requirement

When the maximum length is set, the linkage rod **3**, or linkage rods **3** and **4** on the model LP 8971 must be able to move freely when the balance wheel is turned.



- Set the maximum stitch length.
- Twist or shift the shaft crank **1** ( screw **2**) according to the **Requirement**.

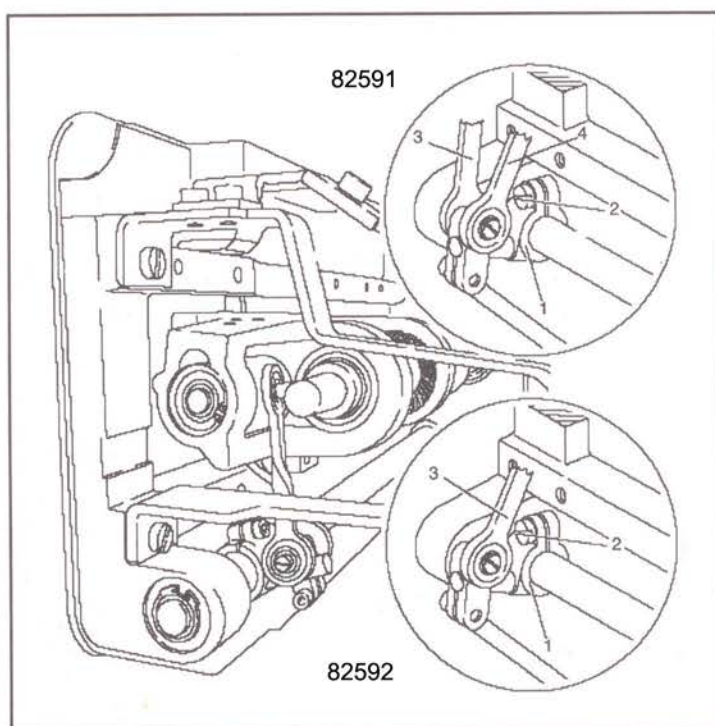

## 7.03.11 Shaft crank to roller presser drive

### Requirement

When the maximum stitch length is set, the linkage rods **3** and **4** must be able to move freely at their left and right point of reversal when the balance wheel is turned.



- Set the maximum stitch length
- Twist or shift the shaft crank **1** (screw **2**) according to the **Requirement**.

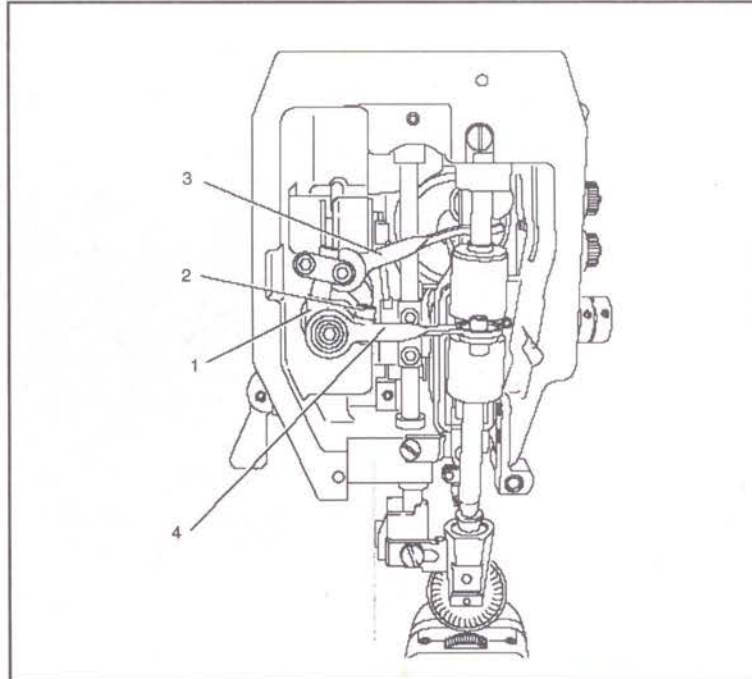

# Adjustment

---

## 7.03.12 Clearance between roller presser and feed wheel

### Requirement

When the presser bar lifter is raised, the clearance between the roller presser and the feed wheel must be **7 mm**.



- Raise the presser bar lifter.
- Adjust the presser bar **1** (screws **2**) according to the **Requirement**. Make sure that the roller presser is parallel to the feed wheel.

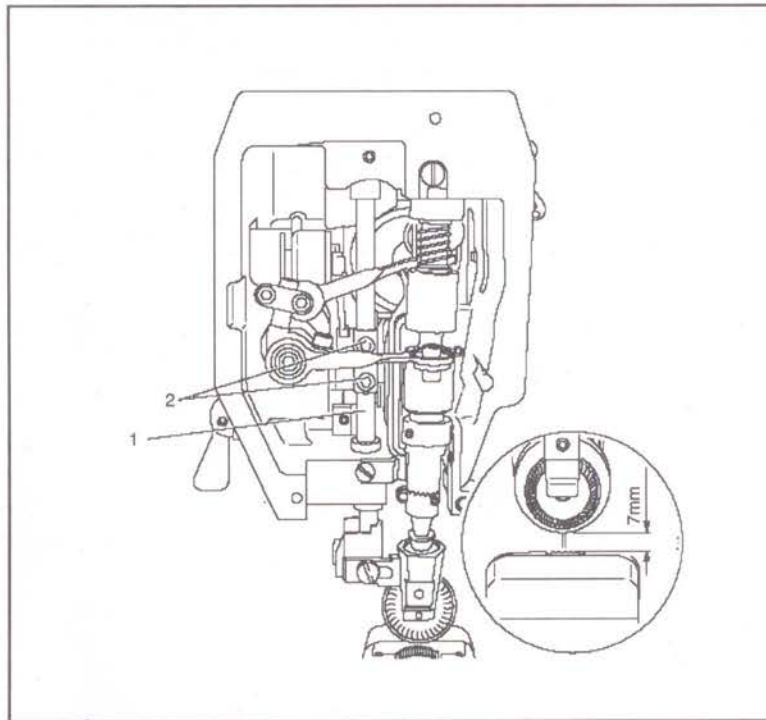

## 7.03.13 Roller presser

### Requirement

When the roller presser **1** is touching the feed wheel **5** it must:

1. be parallel to feed wheel **5**, as seen in the direction of sewing.
2. be in the centre of the needle (on model 8974 the left needle), as seen in the direction of sewing.
3. be as near as possible to the needle (on model 8974 the left needle), as seen crosswise to the direction of sewing.



- Raise the roller presser.
- Always observe **Requirement 1** for subsequent adjustments.
- Adjust roller presser **1** (screw **2**) according to **Requirement 2**.
- Lower roller presser **1** to rest on feed wheel **5**.
- Adjust roller presser bracket **3** (screw **4**) according to **Requirement 3**.

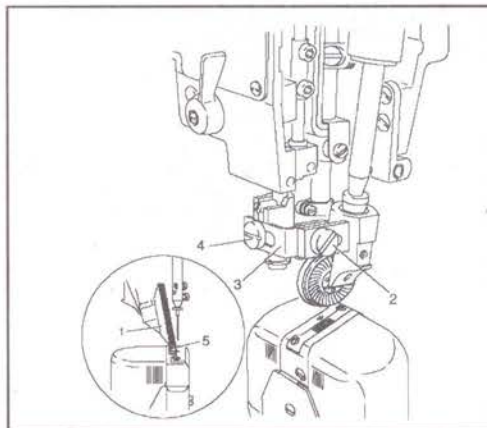

When sewing very tight curves, the roller presser **1** must be moved a little towards the operator.

# Adjustment

---

## 7.03.14 Stitch length on stitch length scale

### Requirement

When the stitch length is set at “3” , and after the needle has entered a strip of leather **11 times**, the total length from the first to last needle penetration must be **30 mm**.



- Set stitch length “3” .
- By turning the balance wheel, let the needle enter **11 times** and measure the total length.
- Adjust clamp **1** (screw **2**) according to the **Requirement**.

Clamp **1** must not be positioned diagonally to the rock shaft!

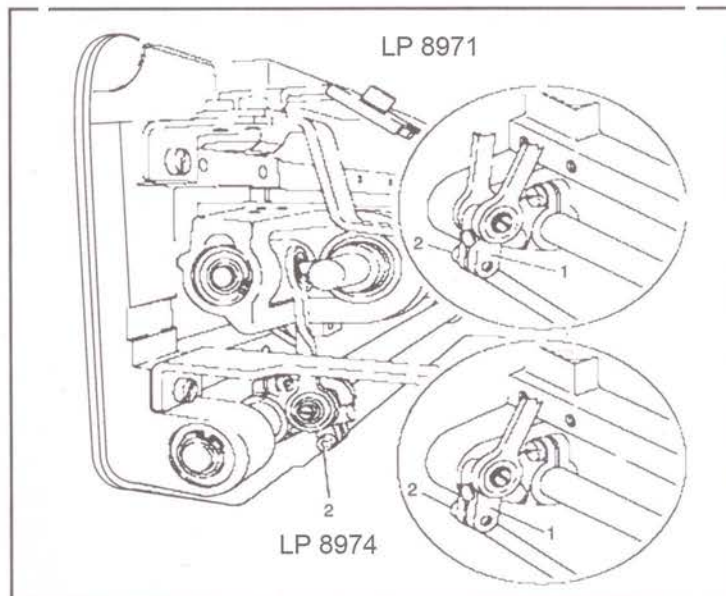

## 7.03.15 Synchronization of roller presser and feed wheel

### Requirement

After **30 needle penetrations** in a strip of leather the total length from the first to the last penetration should be the same, both in the lower and the upper leather layer.



- Set stitch length "3".
- By turning the balance wheel, let the needle enter **30 times**.
- Compare the total sewn length of the lower and upper leather layer.
- Adjust clamp 1 (screw 2) according to the **Requirement**.



Clamp 1 must not be positioned diagonally to the rock shaft.

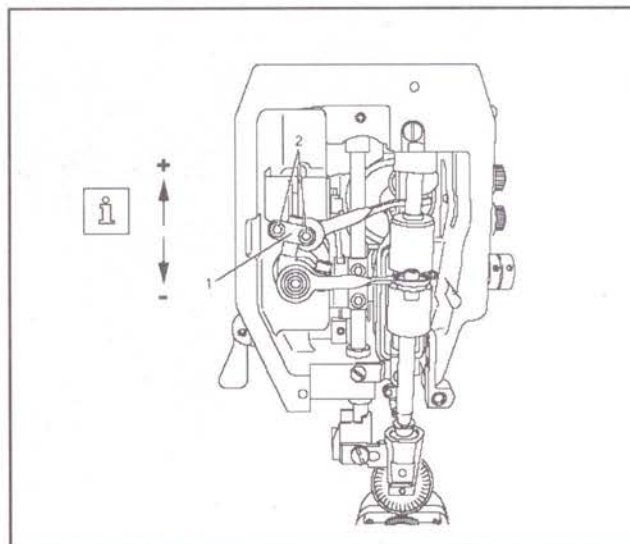

# Adjustment

---

## 7.03.16 Retainer(only on 8974)

### Requirement

The retainer 1 must:

1. be as close as possible to the needle, as seen in the direction of sewing .
2. be in the centre of the needle, as seen crosswise to the direction of sewing.
3. when the roller presser is lowered, the distance between the retainer 1 and the workpiece must be **0.2-0.3 mm**.



- Adjust retainer 1 (screw 2) according to **Requirement 3**.
- Adjust bracket 3 (screw 4) according to **Requirement 1 and 2**.

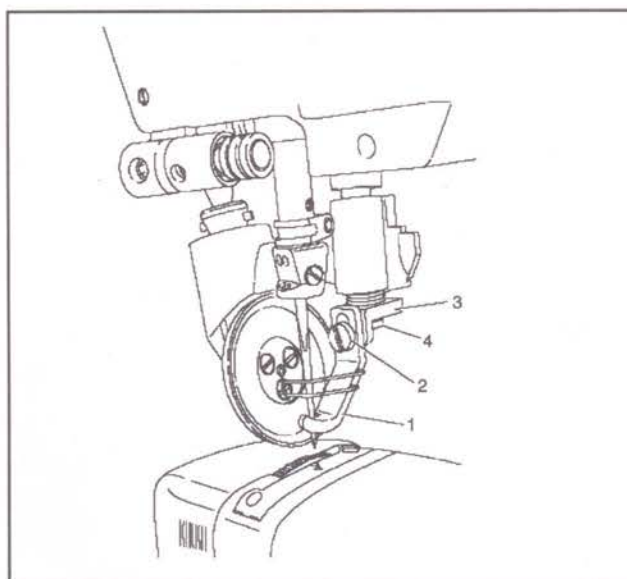

## 7.03.17 Knee lever

### Requirement

1. before the roller presser rises, the knee lever must still have a slight play.
2. when the knee lever is raised as far as possible, the lever for the roller presser must drop automatically.
3. knee lever bar **5** must be at an angle of approx.  $75^\circ$  to the bedplate.



- Adjust screw **1** (nut **2**) according to **Requirement 3**.
- Adjust screw **3** (nut **4**) according to **Requirement 2**.
- Set bar **5** (screws **6**) according to **Requirement 3**.

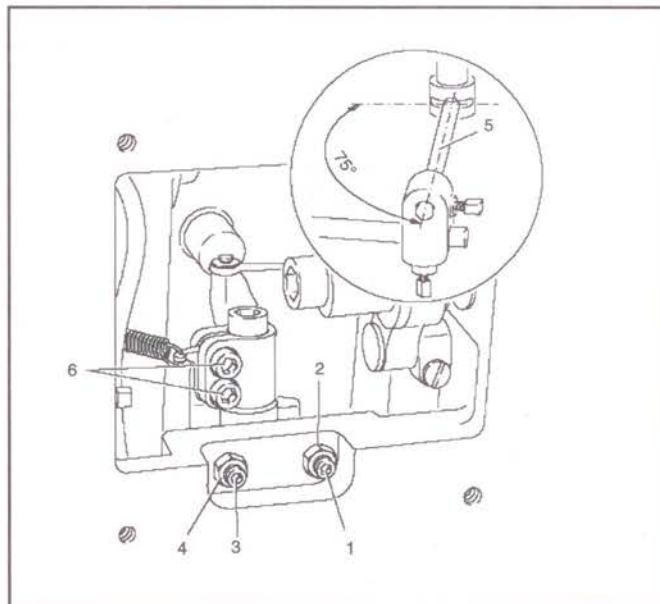



# Adjustment

---

## 7.03.18 Needle thread tension release

### Requirement

1. when the presser bar lifter is raised, the tension discs **3** should be pressed at least **0.5 mm** apart.
2. When the roller presser is lowered, the tension must be fully effective.



- Align tension mounting plate **1** and pressure plate **2** according to **Requirement**.

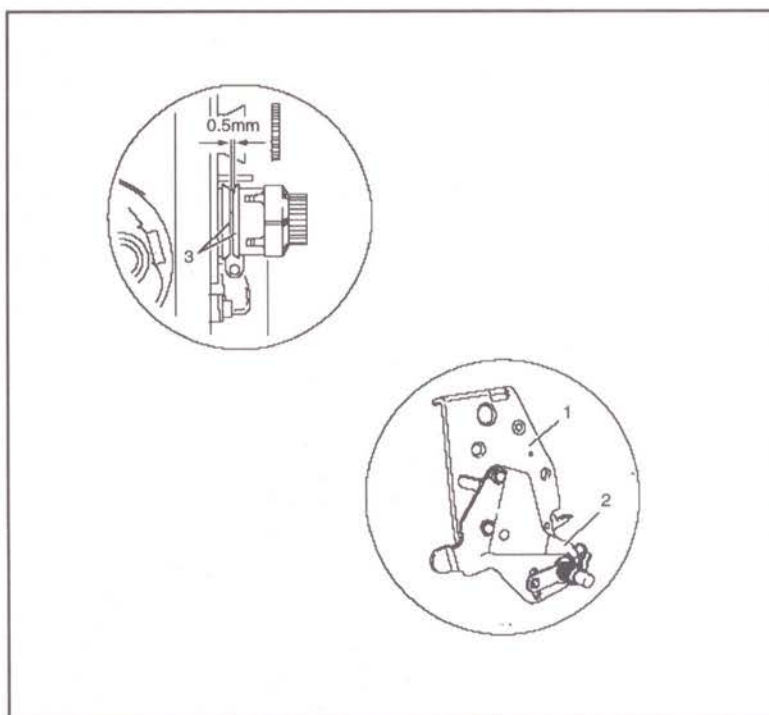

## 7.03.19 Thread check spring

### Requirement

1. the movement of thread check spring 7 should be completed when the needle point penetrate the fabric (spring stroke approx. **7 mm**).
2. when the largest thread loop is formed while the thread is passed around the hook, the thread check spring 7 should rise slightly from its support.



- Adjust support 1 (screw 2) according to **Requirement 1**.
- Adjust the spring tension by turning screw 3 (screw 4).
- Adjust the thread regulator 5 (screw 6) according to **Requirement 2**.



For technical reasons it may be necessary to deviate from the specified spring stroke or spring tension. Move the thread regulator 5 (screw 6) towards “+” (= more thread) or “-” (= less thread).

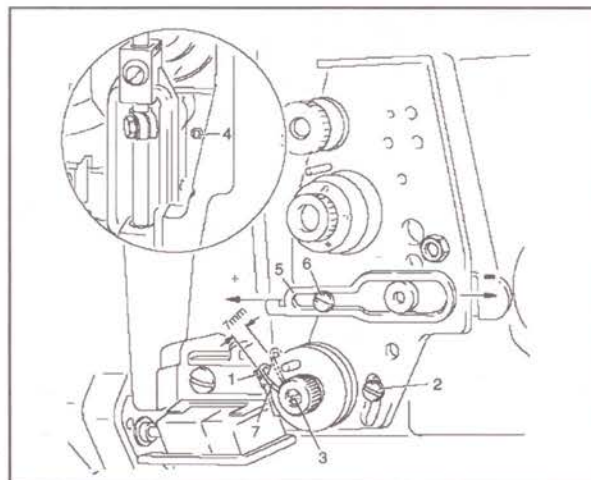

# Adjustment

---

## 7.03.20 Bobbin winder

### Requirement

1. when the bobbin winder is engaged, the winding spindle must be driven reliably. When the bobbin winder is disengaged, the friction wheel 5 must not be moved by drive wheel 1.
2. the bobbin winder must switch itself off, when the filled thread is about 1 mm from the edge of the bobbin.



- Position drive wheel 1 (screws 2) according to **Requirement 1**.
- Position bolt 3 (screw 4) according to **Requirement 2**.

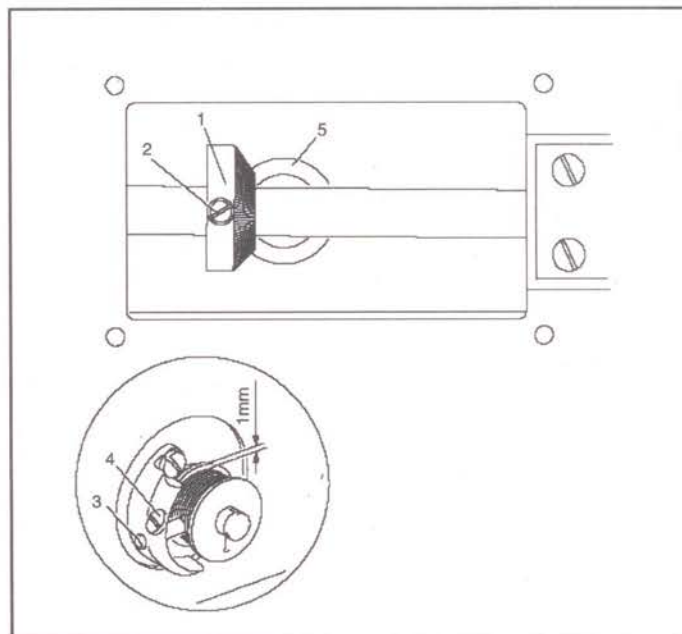

## 7.03.21 Pressure of roller presser

### Requirement

The material must be fed smoothly. No pressure marks should be visible on the material.



- Adjust roller pressure with screw 1 according to the **Requirement**.

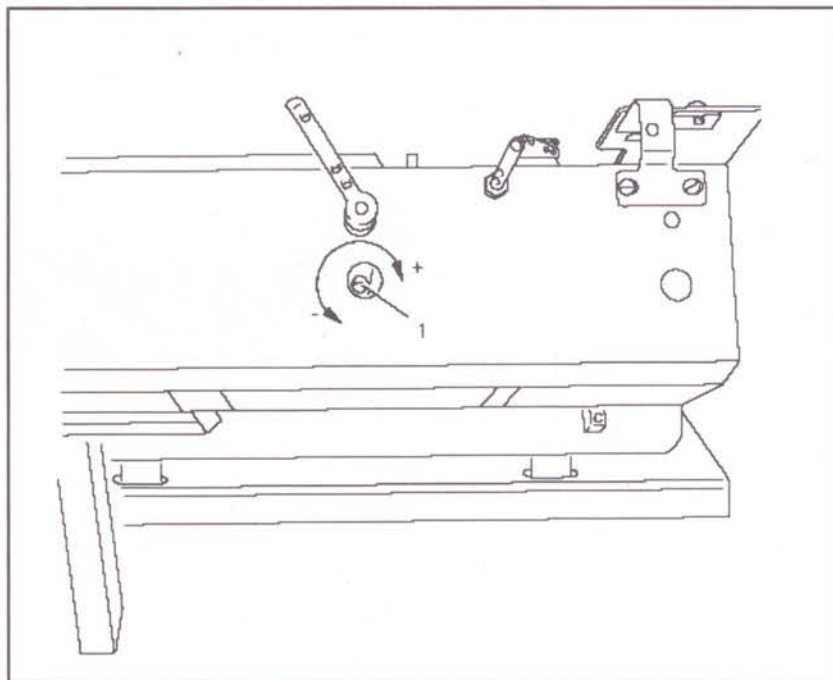

# Adjustment

---

## 7.03.22 Re-engage safety coupling



The coupling 1 is set by the manufacturer. When the thread jams, the coupling 1 disengages in order to avoid damage to the hooks. A description of how to engage the coupling follows.



- Remove jammed thread.
- Hold coupling 1 with screw 2 and turn the balance wheel, until you feel coupling 1 snap back into place again.

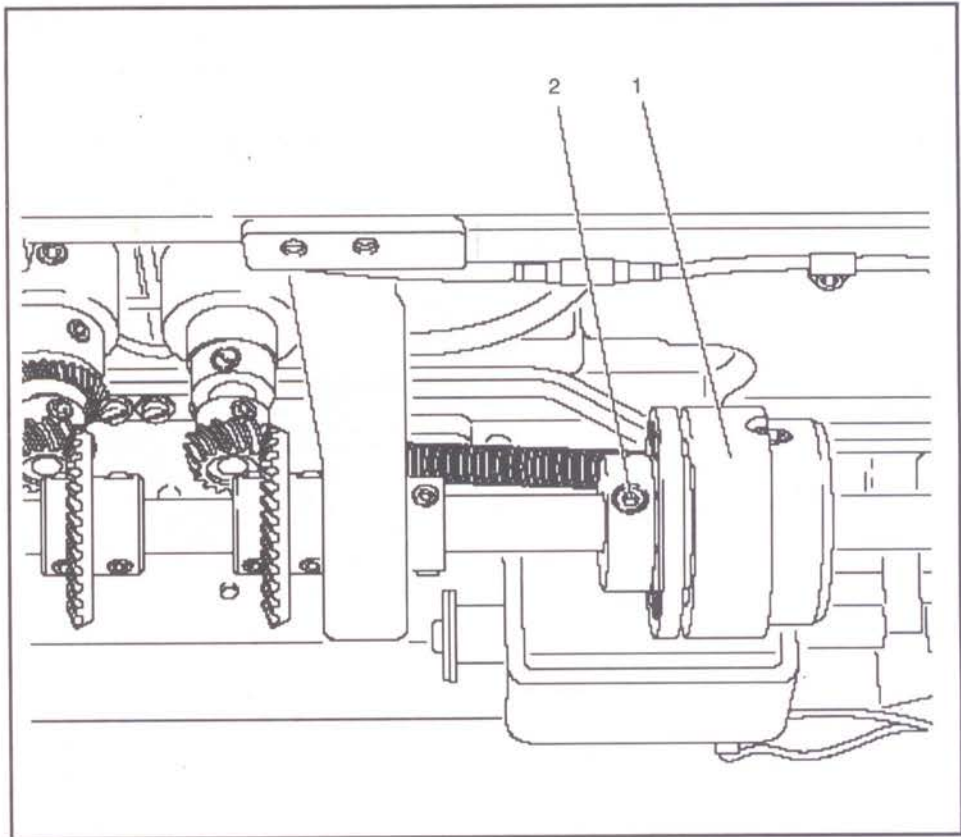

## 7.04 Adjusting the thread trimmer

### 7.04.01 Resting position of the roller lever/ radial position of the control cam

#### Requirement

1. when the thread trimmer is in resting position, lever 5 should be touching piston 6 and the roller of roller lever 7 should be 0.3 mm away from control cam 3.
2. when the take-up lever is at top dead centre, control cam 3 should just have placed roller lever 7 in its resting position.



- Having made sure that piston 6 is positioned against the left stop, adjust magnet 1 (2 screws) in accordance with **Requirement 1**.
- Adjust control cam 3 (screw 4) in accordance with **Requirement 2**.

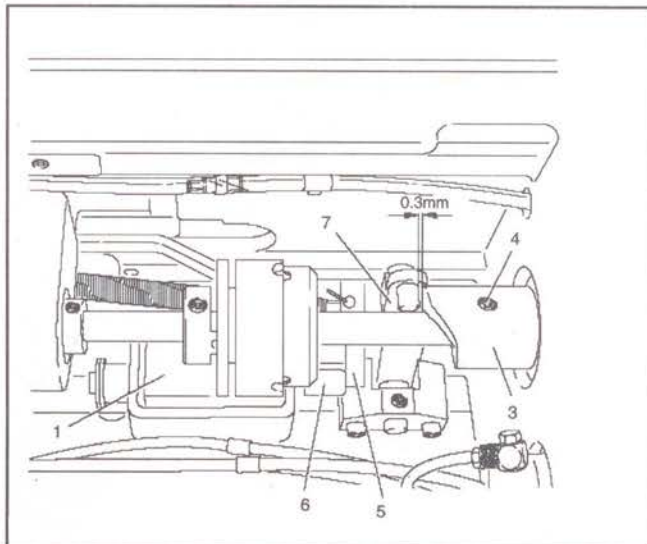

# Adjustment

---

## 7.04.02 Position of the thread catcher holder

### Requirement

1. there should be a minimum amount of play between toothed wheel 3 and toothed segment 4.
2. both in the neutral position and the foremost position of the catcher, the distance between the toothed segment 4 and the outer edge of the thread catcher holder 1 should be the same (see arrow).



- Adjust the thread catcher holder 1 (screws 2) according to Requirements.



- If Requirement 2 cannot be fulfilled, loosen screw 2 and move the toothed segment 4 by one tooth.

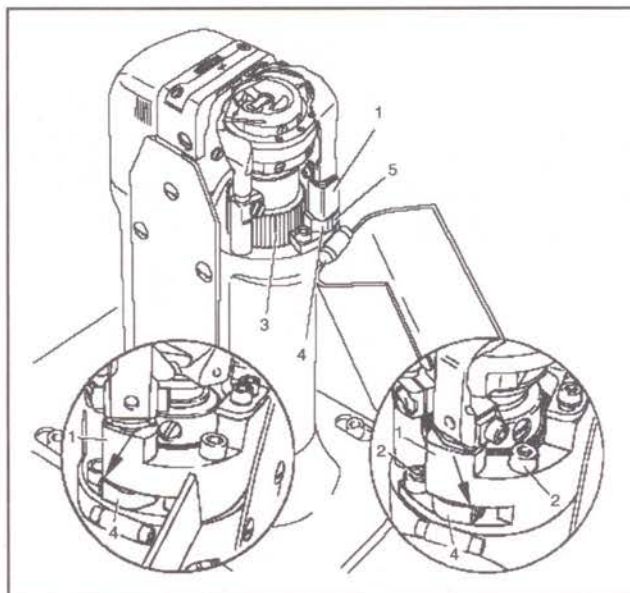

## 7.04.03 Distance between thread catcher and needle plate

### Requirement

During its swivel movement thread catcher 1 should not pass the edge of the needle plate (see arrow).



- Move thread catcher 1 (screws 2, two screws) parallel to the thread catcher holder in accordance with the **Requirement**.

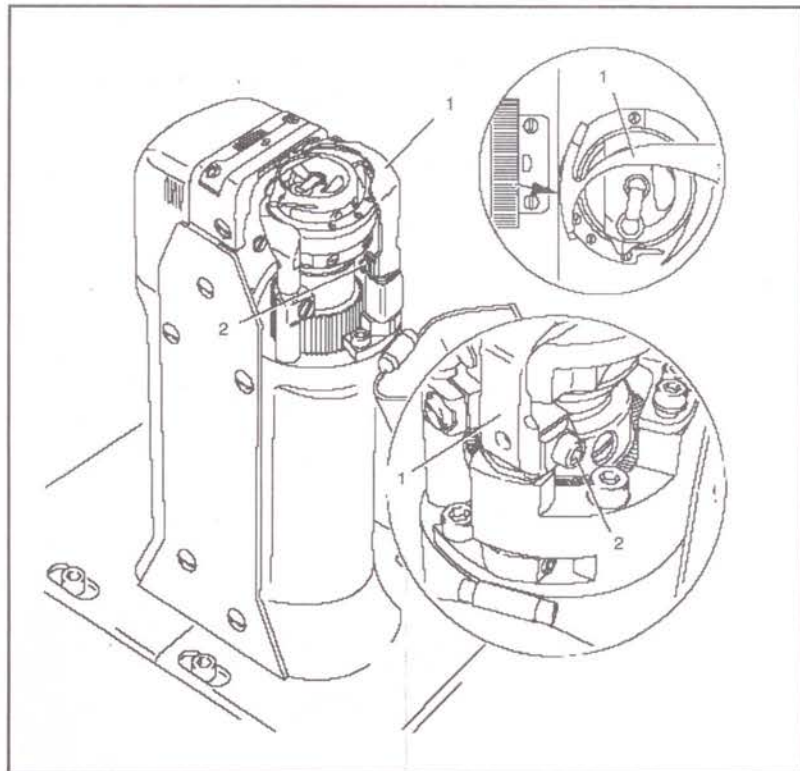



# Adjustment

## 7.04.04 Position of the thread catcher

### Requirement

1. the bottom edge of the thread catcher **1** should be at a distance of **0.1 mm** from the positioning finger of the bobbin case **5**.
2. when the thread trimmer is in its neutral position, the rear edge of thread catcher should be positioned approx. **2.5 - 3 mm** behind the edge of the knife.



- Move thread catcher **1** (screw **2**, two screws) in accordance with **Requirement 1**.
- Turn thread catcher **1** (screw **3**) in accordance with **Requirement 2**.



Thread catcher **1** must be parallel to the surface of the thread catcher holder **4**.

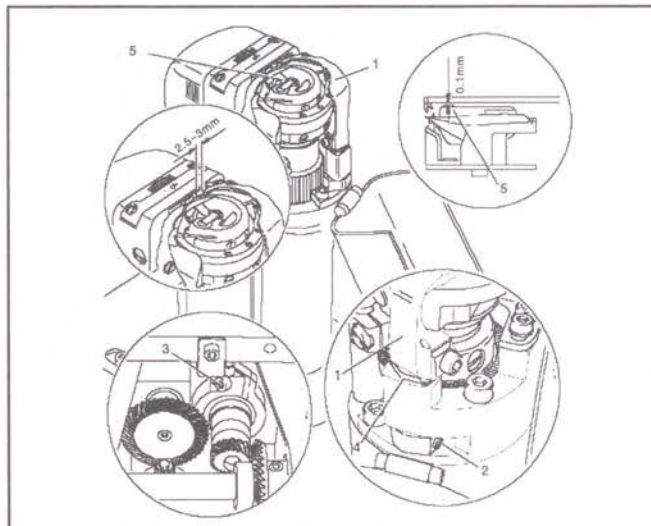

## 7.04.05 Bobbin thread retaining spring

### Requirement

1. the bobbin thread clamp spring should be guided reliably in the thread groove of the thread catcher 3.
2. the tension of the bobbin thread spring clamp should be as low as possible, but the bobbin thread should be reliably after the cutting operation.

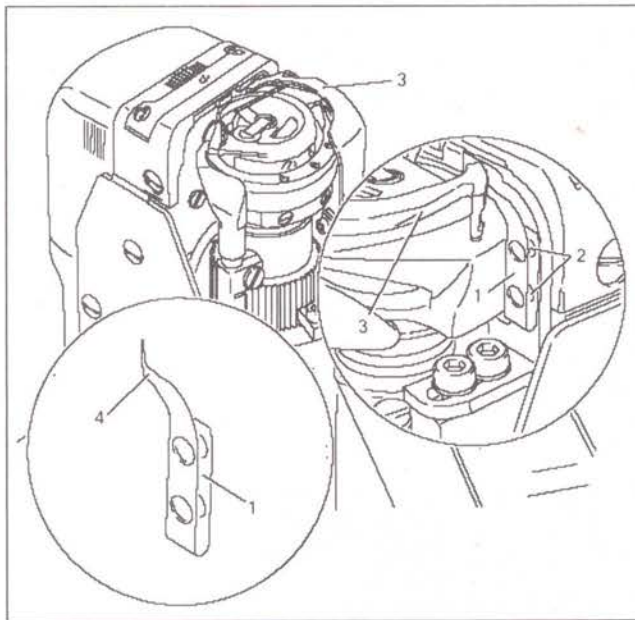

- Adjust bobbin thread clamp spring 1 (screw 2) in accordance with **Requirement 1**.
- Adjust the tension in accordance with **Requirement 2** by bending side 4 of the bobbin thread clamp spring 1.

### Control requirement 1

- Switch off the machine and bring the take-up lever to its bottom dead centre.
- Engage and disengage the thread catcher 3 by hand and check **Requirement 1**. Adjust if necessary.

### Control requirement 2

- After the thread has been cut, sew a few stitches by turning the balance wheel, checking whether the bobbin thread is drawn out of the bobbin thread clamp spring between the 1<sup>st</sup> and 3<sup>rd</sup> stitched, if necessary, correct the tension.

# Adjustment

---

## 7.04.06 Manual cutting test

### Requirement

1. when thread catcher **1** is on its forward stroke, it must not carry bobbin thread **3** forward too.
2. when thread catcher **1** is in its front position, bobbin thread **3** must be held reliably by hook **4**.
3. After the trimming action, both the needle thread and the bobbin thread must be perfectly cut and bobbin thread **3** retained.

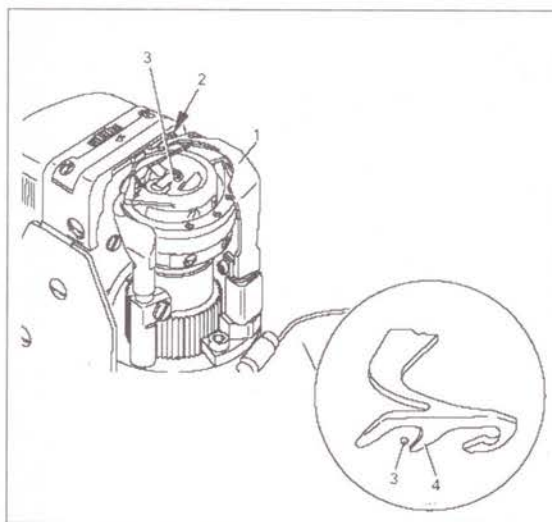

- Sew a few stitches.
- Turn off the on/off switch.
- Carry out the cutting operation manually.
- Check **Requirement 1** and **2**, and if necessary readjust thread catcher **1** in accordance with **Chapter 7.04.04 Position of the thread catcher**.
- Check **Requirement 3**, and if necessary readjust the bobbin thread retaining spring **2** in accordance with **Chapter 7.04.05 Bobbin thread retaining spring**.

## 7.04.07 Releasing the tension

### Requirement

When the magnet is activated, tension discs **3** must be at least **0.5 mm** apart.

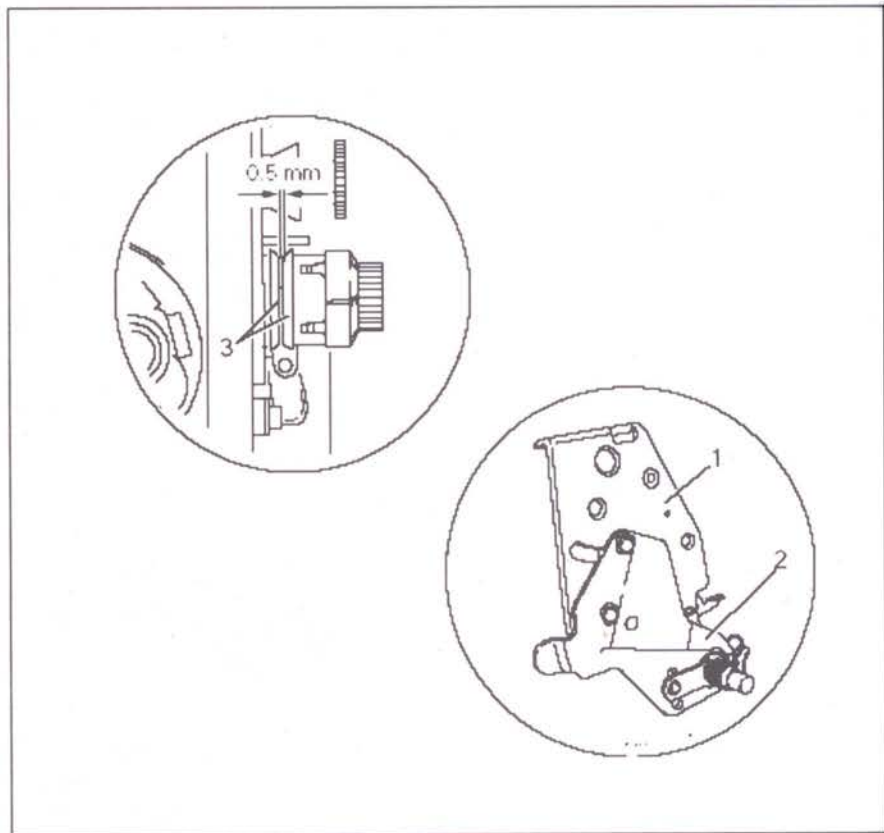

- Activate the magnet.
- Detach the tension bearing plate **1** and adjust pressure plate **2**.

# Adjustment

---

## 7.04.08 Linkage rod (only for the 8972 )

### Requirement

When the thread trimmer is in its resting position, the drive levers **1** must be parallel.

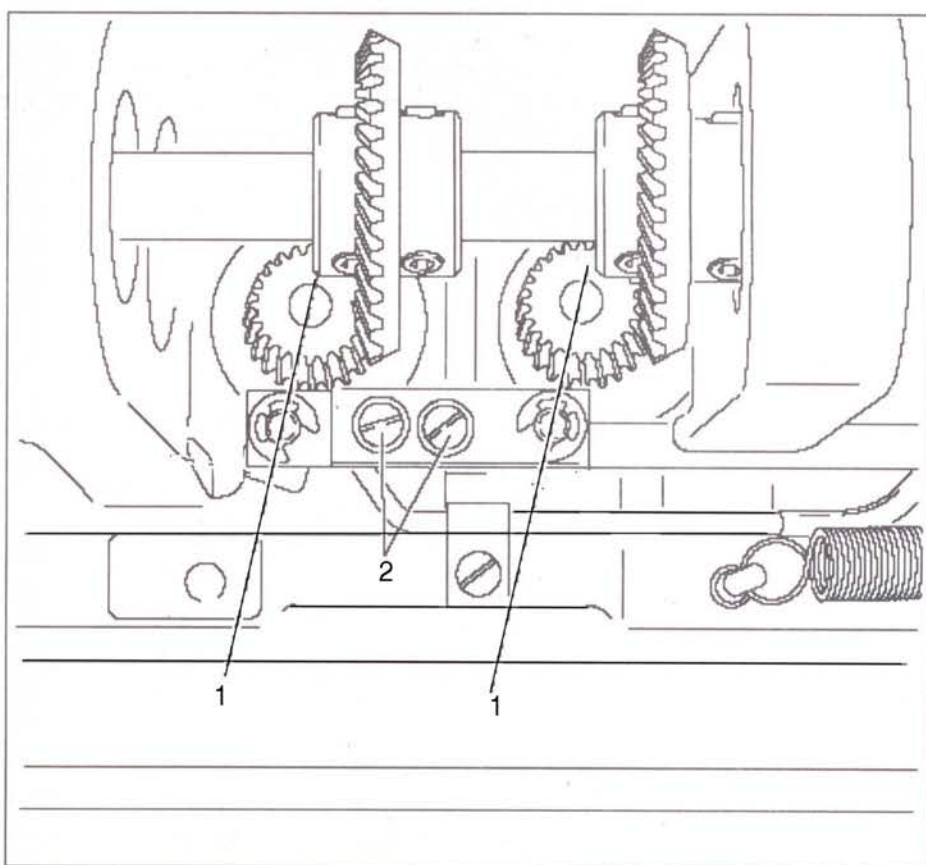

● Adjust drive levers **1** (screw **2**) in accordance with the **Requirement**.

## 7.05 Adjusting backtacking mechanism

### 7.05.01 Needle in needle hole (only for pneumatic machine)

#### Requirement

When the maximum stitch length is set, the needle must be the same distance from the inside edge of the needle hole, both for forward and reverse stitch.

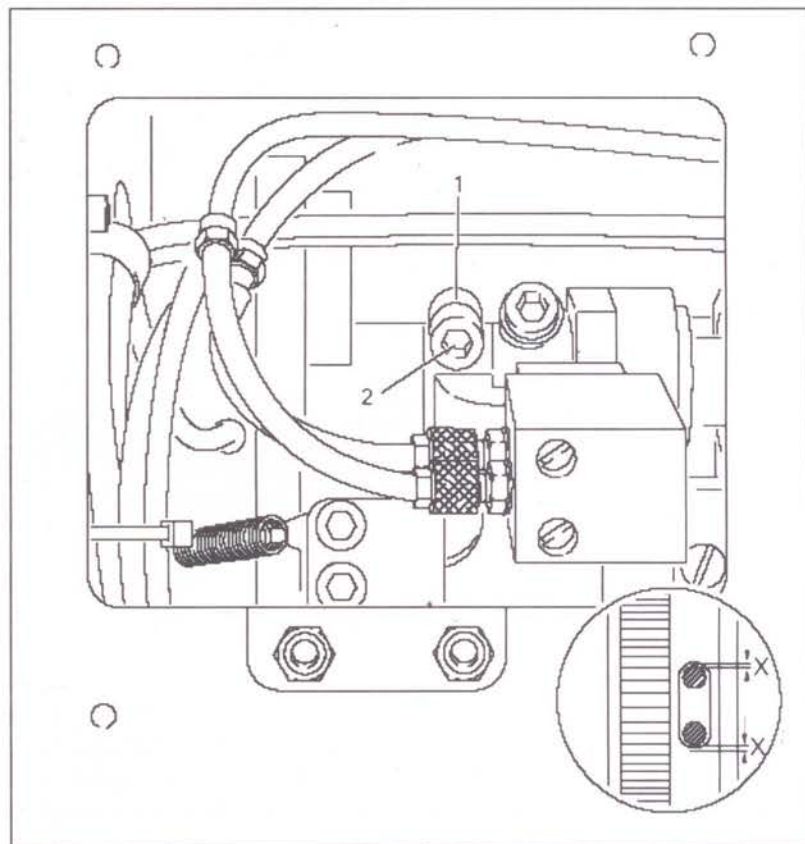

● Turn crank 1 (screw 2) according to the **Requirement**,

## Adjustment

---

### 7.05.02 Needle in needle hole (only for LP 98971 )

**Requirement:**

When the maximum stitch length is set, needle bar should at lowest position.  
Press back tacking spanner, needle bar should keep quiescent condition.

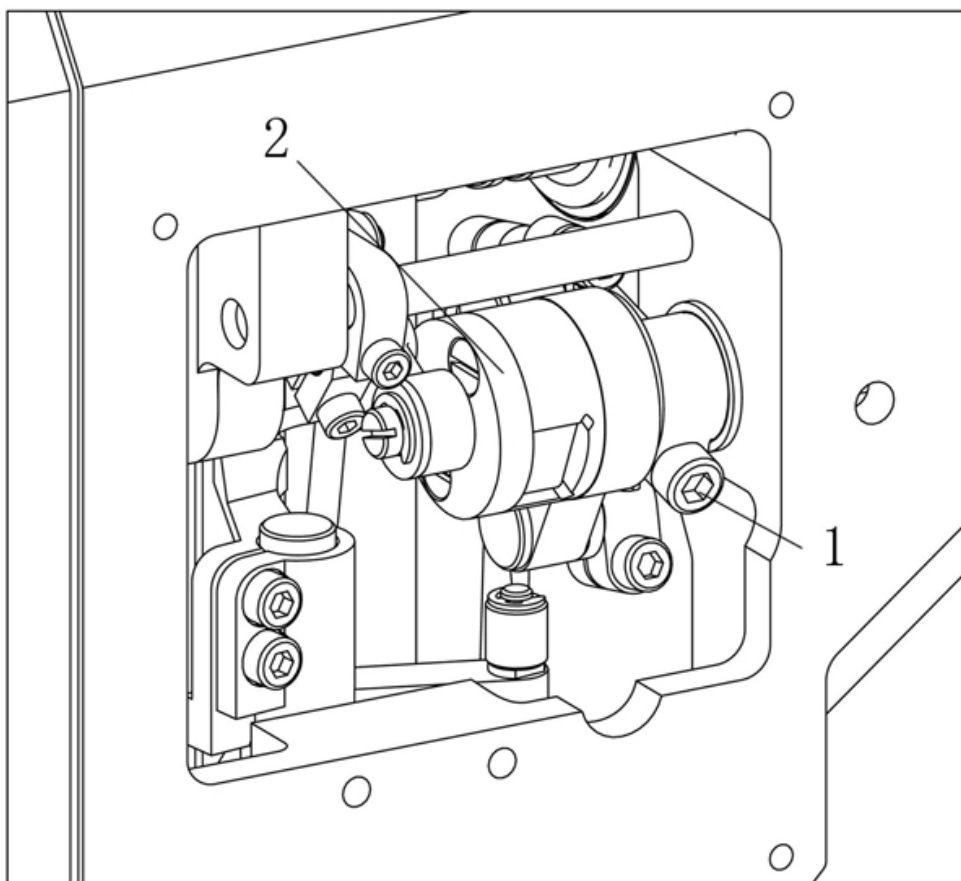

- Turn adjustment crank 2 (screw 1) according to requirement.

## 7.05.03 Coupling for roller presser drive

### Requirement

There must be a distance of **3 mm** between coupling half 1 and locking disc 3 of the drive mechanism.

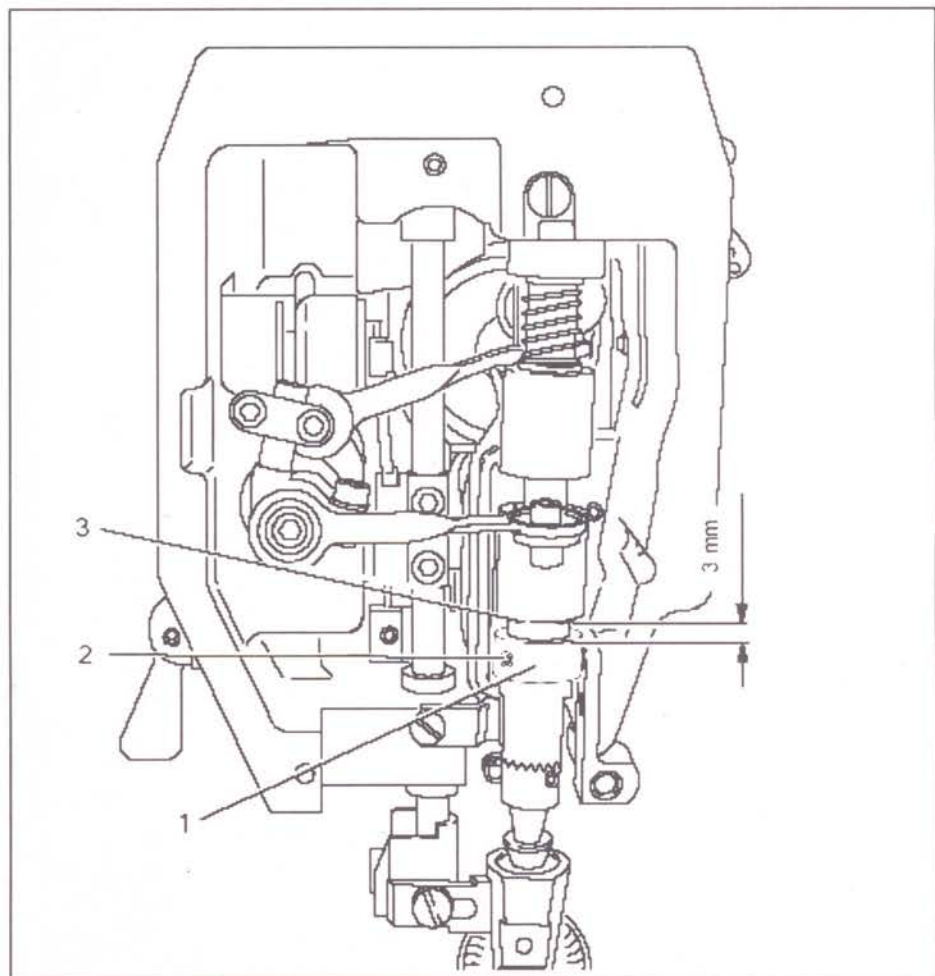

- Adjust coupling half 1 (screw 2) according to the **Requirement**.



## Adjustment

---

### 7.05.04 Adjustment for roller presser clutch device ( only for LP 8971 )

#### Requirement

1. When sewing forwarders, turn up-feeding wheel by hand, up-feeding wheel by hand 4 just can be rotated in counterclockwise.
2. When sewing forwarders, turn up-feeding wheel by hand, up-feeding wheel by hand 4 can be rotated in counterclockwise and clockwise.

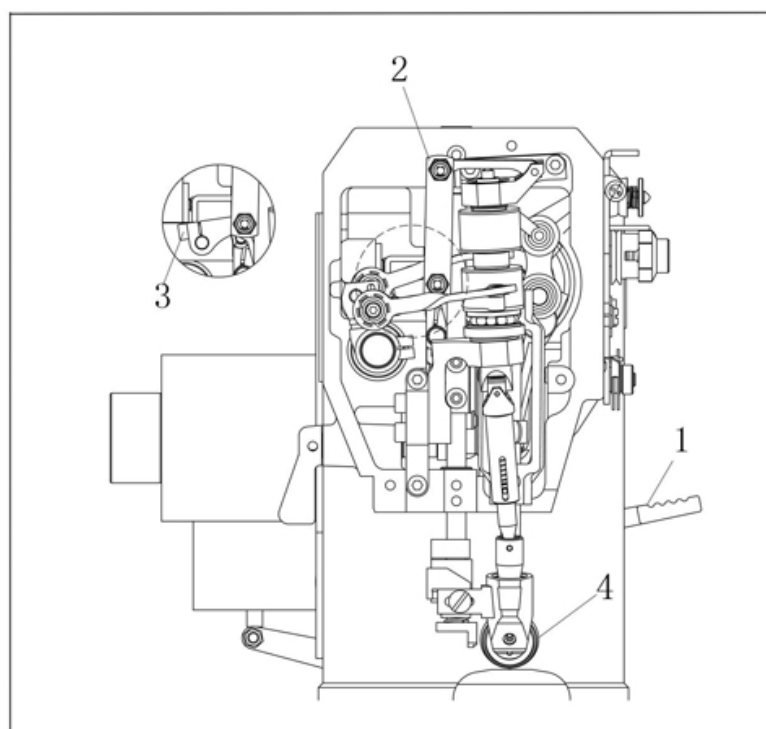

- Press back-tacking spanner 1.
- Adjust connecting pate 2 (screw 3) according to requirement.

## 7.05.05 Bevel gears for feed wheel drive (only for pneumatic machine)

### Requirement

1. bevel gear 3 must fit well on the left side.
2. there must be a distance of 14 mm between bevel gear 3 and bevel gear 5.

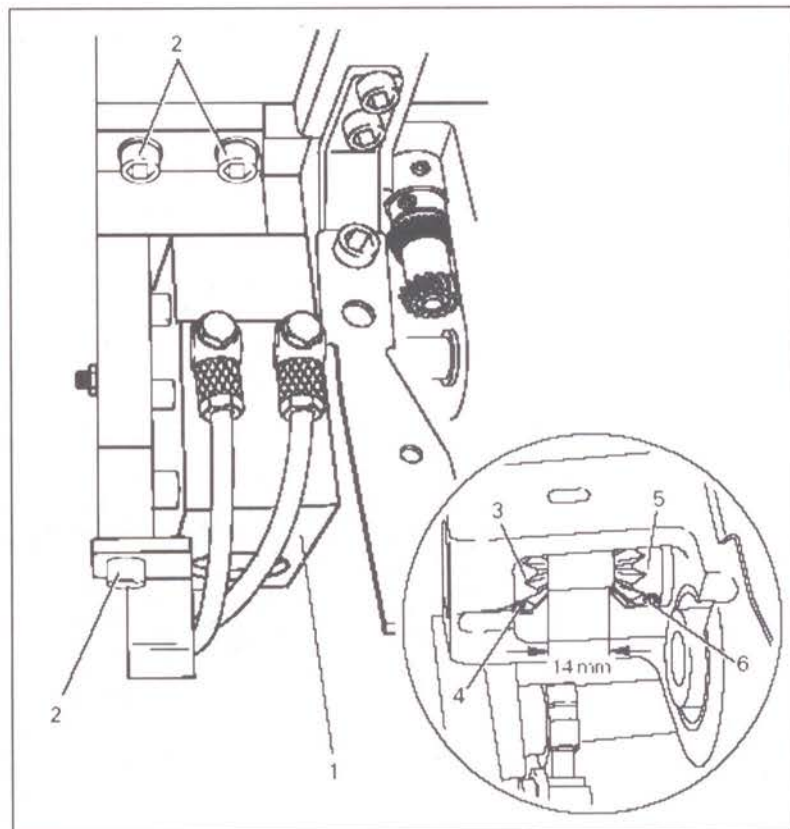

- Remove control unit 1 (screws 2).
- Adjust bevel gear 3 (screw 4) according to **Requirement 1**.
- Adjust bevel gear 5 (screw 6) according to **Requirement 2**.

# Adjustment

## 7.05.06 Bevel gears for feed wheel drive (on the LP 8971 )

### Requirement

1. the right side of bevel gear 1 must be flush with its drive shaft (see arrow).
2. there must be a distance of **13 mm** between bevel gear 3 and bevel gear 1.

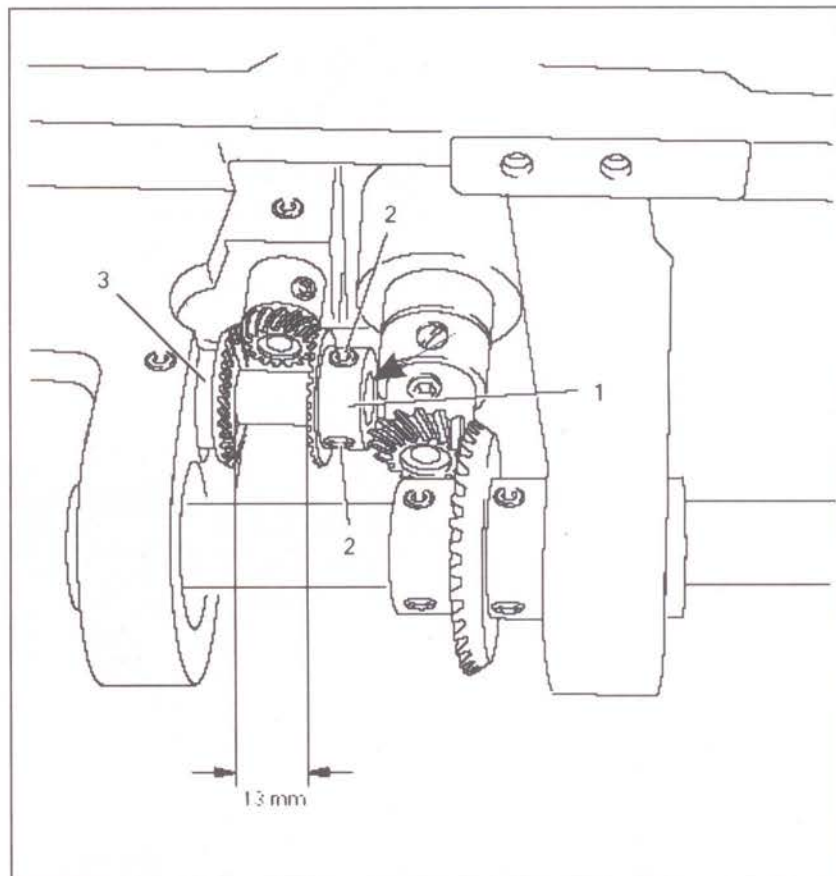

- Adjust bevel gear 1 (screws 2) according to **Requirement 1**.
- Adjust bevel gear 3 (screws 4) according to **Requirement 2**.

## 7.05.07 Bevel gear play (only for pneumatic machine)

### Requirement

1. when sewing forwards, there must be a slight play between bevel gear 6 and 7.
2. When sewing backwards, there must be a slight play between bevel gear 6 and 8.

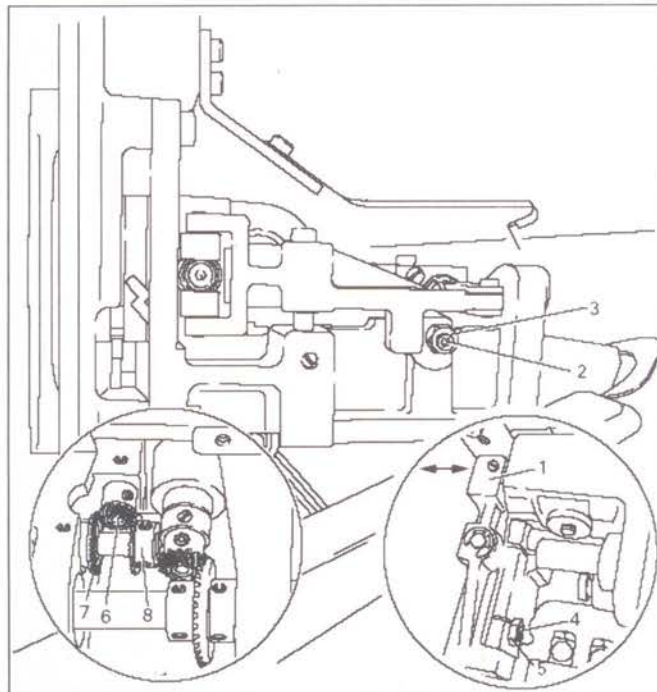

- Disconnect air supply of the air filter/lubricator.
- Move unit 1 by hand as far as possible to the right (see arrow).
- Adjust screw 2 (nut 3) according to **Requirement 1**.
- Move unit 1 by hand as far as possible to the left (see arrow).
- Adjust screw 4 (nut 5) according to **Requirement 2**.

DIRECT DRIVEN POST BED SEWING  
MACHINE WITH WHEEL FEED AND DRIVEN  
ROLLER PRESSER

PARTS LIST



# CONTENT

A. Arm bed and its accessories.....	2
B. Presser bar parts.....	4
C. Needle bar holder parts.....	6
D. Thread tension regulator parts.....	8
E. Main shaft driving parts.....	10
F. Upper side shaft feed parts.....	12
G. Presser foot lifting parts.....	14
H. Bobbin winder parts.....	16
I. Stitch length adjustment parts.....	18
J. Clutch set parts.....	20
K. Oil lubrication parts.....	22
L. Hook parts (Left).....	24
M. Left side bracket parts.....	26
N. Hook parts (Right).....	28
O. Right side bracket parts.....	30
P. Bed plate feed parts.....	32
Q. Solenoid for thread trimming parts.....	34
R. Thread trimming driving parts.....	36
S. Solenoid for presser foot lifting parts.....	38
T. Upper feed and backstitch parts.....	40
U. Lower feed and backstitch parts for single needle.....	42
V. Lower feed and backstitch parts for double needle.....	44
W. Power cable connection.....	46
X. Parts of integrated machine.....	48
Y. Accessories.....	50

## A. Arm bed and its accessories

No.	Part No.	Name	1 Needle	2 Needle
1	7.02.01.068	Arm bed	1	1
2	7.02.21.467	Back cover (1)	1	1
3		Back cover (2)	1	1
4	7.02.15.096	Back cover screw	7	7
5	7.02.11.482	Lower plate	1	1
6	7.02.15.044	Lower plate screw	3	3
7	7.02.11.483	Safety guard cover	1	1
8	7.02.15.964	Safety guard cover screw	1	1
9	7.02.11.484	Fixed plate	1	1
10	7.02.15.444	Fixed plate screw	2	2
11	7.02.13.370	Bracket	1	
	7.02.13.378	Bracket		1
12	7.02.15.055	Bracket screw	2	2
13	7.02.11.499	Face plate	1	1
14	7.02.15.731	Face plate screw (Lower)	1	1
15	7.02.15.974	Face plate screw (Upper)	1	1
16	7.02.11.37101	Back cover plate (Left)	1	1
17	7.02.15.960	Back cover plate screw	4	4
18	7.02.16.408	Oil cap	1	1
19	7.02.16.407	Oil cap	1	1
20	7.02.15.960	Screw	1	1
21	7.02.13.379	Thread take-up lever guard cover	1	1
22	7.02.16.412	Plastic safe guard cover	1	1
23	7.02.15.416	Screw	2	2
24	7.02.15.016	Washer	3	3
25	7.02.18.018	Elastic washer	1	1
	7.02.18.017	Washer	1	1
26	7.02.15.068	Nut	2	2
27	7.02.15.960	Screw of back cover plate	4	4
28	7.02.11.37201	Back cover plate (right)	1	1
29	7.02.14.080	Thread guide (Face cover)	1	1
30	7.02.16.299	Felt	1	1



# A. Arm bed and its accessories

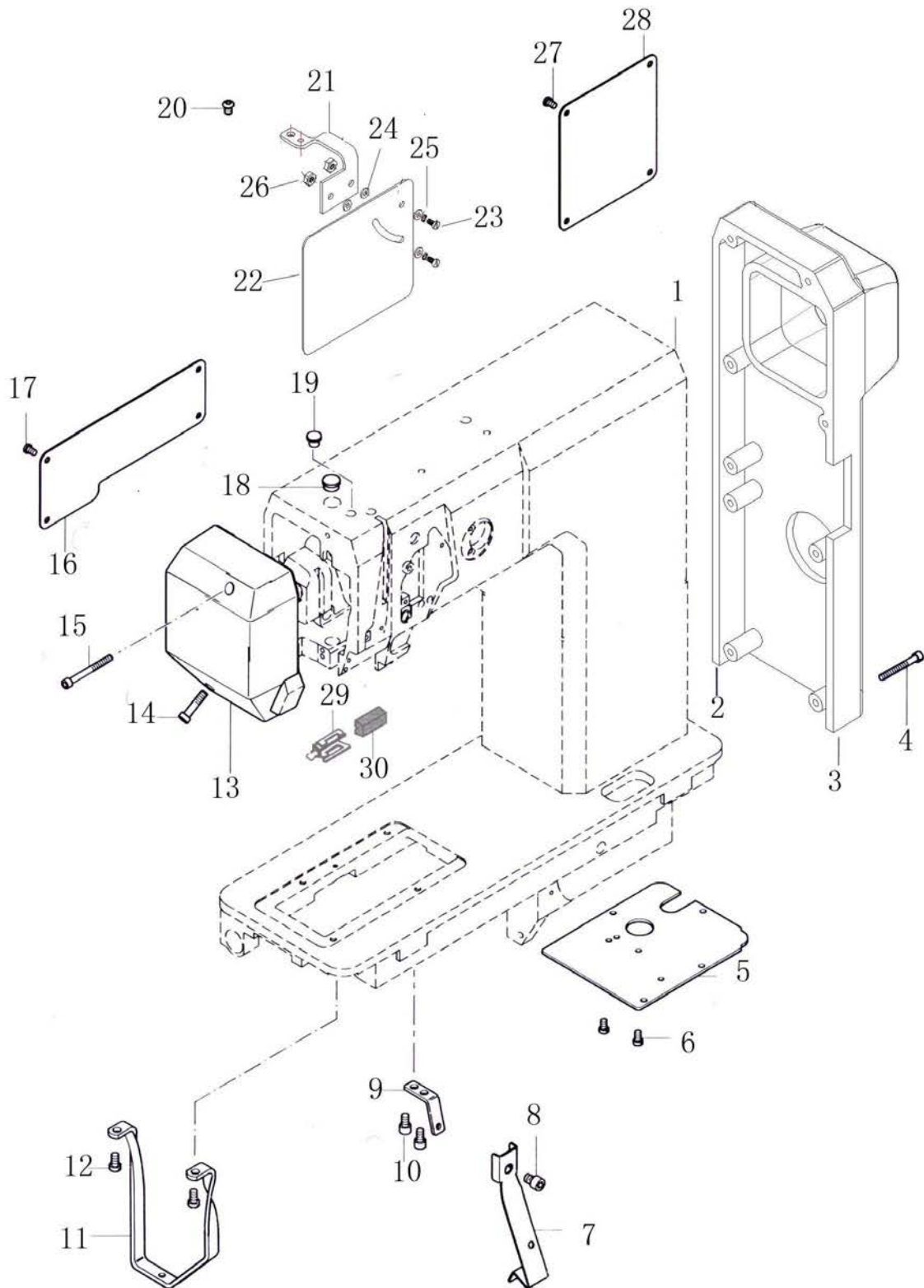

### B.Presser bar parts

No.	Part No.	Name	1 Needle	2 Needle
1	7.02.05.01101	Presser foot lifting lever	1	1
2	7.02.15.056	Set screw	1	1
3	7.02.15.049	Screw	2	2
4	7.02.15.057	Set screw	2	2
5	7.02.15.025	Screw	1	1
6	7.02.08.032	Bushing (Upper)	1	1
7	7.02.08.033	Bushing (Lower)	1	1
8	7.02.03.009	Guide rail bar	1	1
9	7.02.08.007	Presser bar position bracket	1	1
10	7.02.15.050	Screw	2	2
11	7.02.03.420	Presser bar lifter shaft	1	1
12	7.02.15.061	Screw	2	2
13	7.02.09.117	Collar	1	1
14	7.02.15.056	Screw	2	2
15	7.02.12.280	Lift block	1	1
16	7.02.03.421	Presser bar	1	1
17	7.02.10.457	Stopper pin	1	1
18	7.02.15.011	Screw	1	1
19	7.02.08.470	Roller presser bracket	1	1
20	7.02.17.011	Spring	1	1
21	7.02.05.009	Tailstock	1	1
22	7.02.18.071	Washer	1	1
23	7.02.15.066	Screw	1	1
24	7.02.02.008	Small presser foot	1	1
25	7.02.17.009	Safety spring	1	1
26	7.02.15.026	Screw	1	1
27	7.02.17.012	Spring	1	1
28	7.02.01.351	Thread tension regulator assy	1	1

# B.Presser bar parts

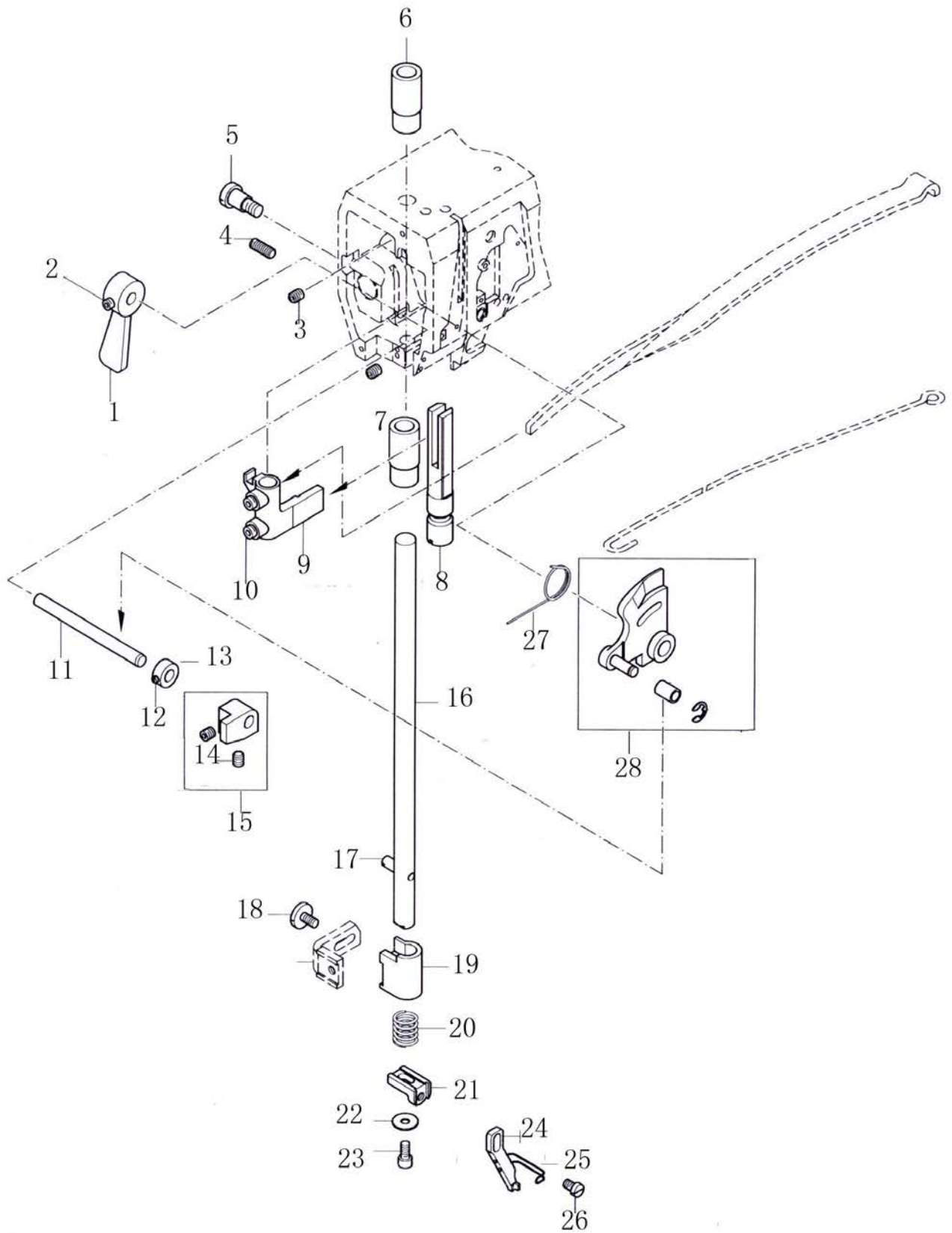

### C. Needle bar holder parts

No.	Part No.	Name	1 Needle	2 Needle
1	7.02.01.353	Thread take-up assy.	1	1
2		Thread take-up fixed pin	1	1
3		Plastic stop ring	2	2
4		Needle bearing	2	2
5		Thread take-up holder	1	1
6		Thread take-up shaft bushing	1	1
7	7.02.15.049	Set screw	2	2
8		Screw	1	1
9		Thread take-up lever	1	1
10		Bearing	1	1
11		Bearing	1	1
12	7.02.18.030	Elastic retaining ring	2	2
13		Thread path	1	1
14	7.02.06.001	Thread take-up crank	1	1
15	7.02.05.005	Needle bar connector	1	1
16	7.02.04.006	Needle bearing	1	1
17	7.02.18.009	Washer	1	1
18	7.02.05.006	Needle bar fixer	1	1
19	7.02.15.066	Needle bar fixer screw	1	1
20	7.02.16.011	Oil felt	1	1
21	7.02.12.001	Needle bar connector guide slot	1	1
22	7.02.15.021	Guide slot screw	2	2
23	7.02.12.002	Needle bar guide slide block	1	1
24	7.02.16.012	Oil felt	1	1
25	7.02.17.005	Oil felt holder	3	3
26	7.02.15.022	Oil felt pressing plate screw	2	2
27	7.02.17.001	Fixed plate of needle bar holder		1
28	7.02.15.022	Fixed plate screw		1
29	7.02.15.064	Set screw		1
30	7.02.08.025	Bushing		1
31	7.02.08.026	Bushing		1
32	7.02.13.001	Needle bar holder	1	1
33	7.02.10.012	Pin	1	1
34	7.02.03.007	Main shaft	1	1
35	7.02.09.001	Collar	1	1
36	7.02.15.054	Set screw	1	1
37	7.02.03.006	Needle bar	1	
	7.02.03.018	Needle bar		1
38	7.02.15.019	Needle clamp screw	1	
39	7.02.14.005	Needle bar thread stand		
40	7.02.18.002	Disk type washer	2	
41	7.02.04.010	Needle bearing	2	
42	7.02.08.004	Bushing	2	
43	7.02.08.024	Needle clamp bushing		1
44	7.02.15.040	Bushing screw		1
45	7.02.02.503	2.4 MM Needle holder		1
46		Needle holder screw		2

### C. Needle bar holder parts

---

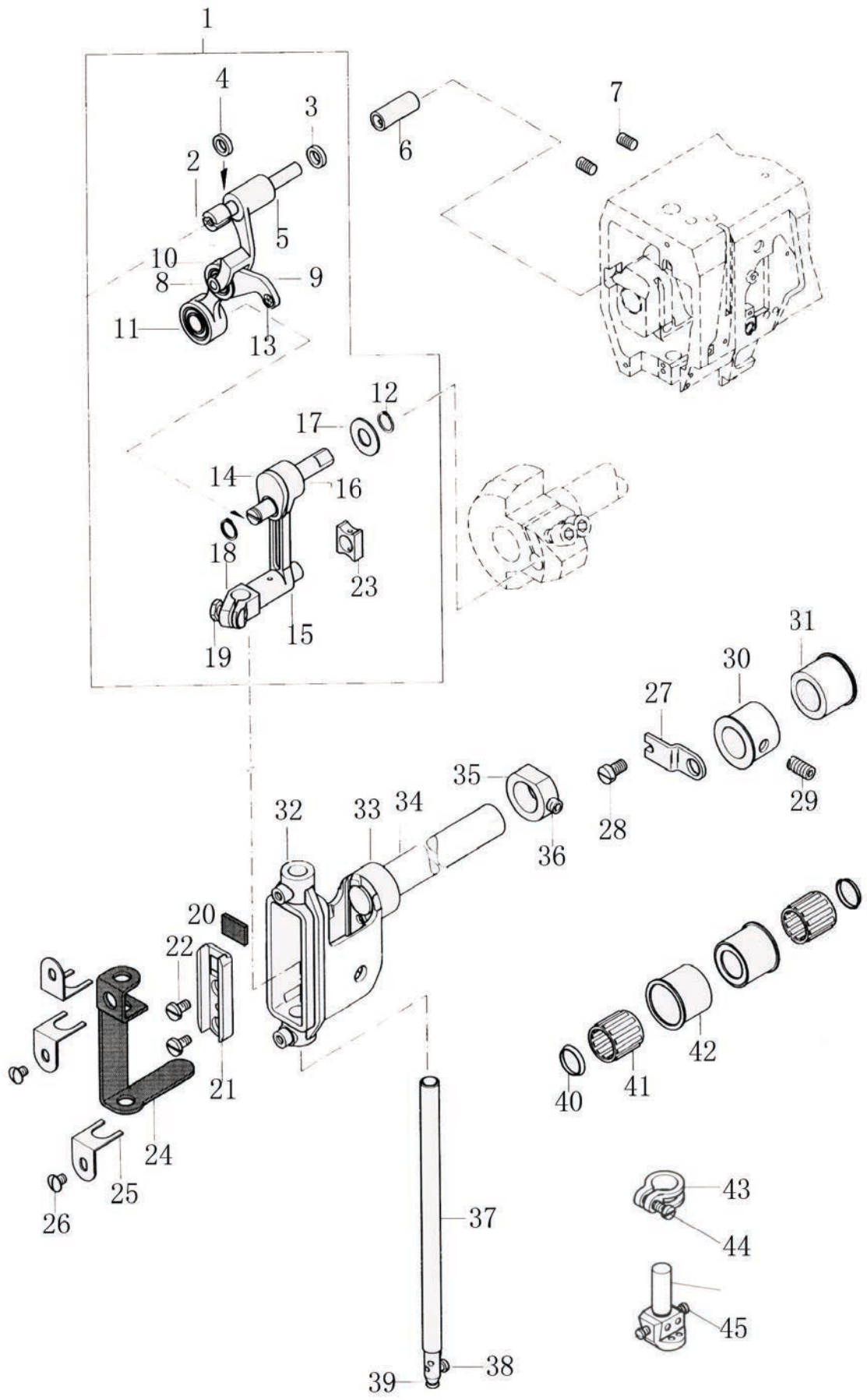

## D.Thread tension regulator parts

No.	Part No.	Name	1 Needle	2 Needle
1	7.02.01.280	Thread tension regulator assy.	1	
1-1		Nut	1	
2	7.02.01.282	Thread tension regulator assy.		1
2-1.		E type ring		1
2-2.		Thread tension plate(Small)	1	2
2-3.		Spring	1	2
2-4.		Screw	1	2
2-5.		Nut	1	1
2-6.		Screw	1	1
2-7.		Thread guide plate	1	2
2-8.		Screw	1	1
2-9.		Thread tension disk	2	4
2-10.		Tension disk	1	2
2-11.		Washer	1	2
2-12.		Washer	1	1
2-13.		Screw	1	1
2-14.		Adjusting spring	1	2
2-15.		Nut	1	2
2-16.		Position shaft		1
2-17.		Bushing collar		1
2-18.		Screw		1
2-19.		Screw		1
2-20.		Washer		1
2-21.		Spring adjuster		1
2-22.		Thread take-up spring		1
2-23.		Fixed plate		1
2-24.		Spring disk	1	2
2-25.		Washer	1	1
2-26.		Ring	1	1
2-27.		Thread take-up spring	1	1
2-28.		Thread tension stud	1	
2-28-1		Thread tension stud		1
2-29	7.02.15.960	Screw	1	1
2-30		Thread tension releasing plate	1	1
2-31		E type ring	2	2
2-32		Thread releasing pin	1	1
2-33		Thread releasing pin	1	1
2-34		Fixed pin	2	2
2-35		Thread releasing pin	1	2
2-36		Thread releasing pin	1	1
2-37	7.02.15.049	Screw	1	1
3	7.02.14.110	Lower thread guide claw	1	1
4	7.02.15.965	Lower thread guide claw screw	1	1
5	7.02.14.004	Thread stand	1	1
6	7.02.15.960	Thread stand screw	1	1

# D.Thread tension regulator parts

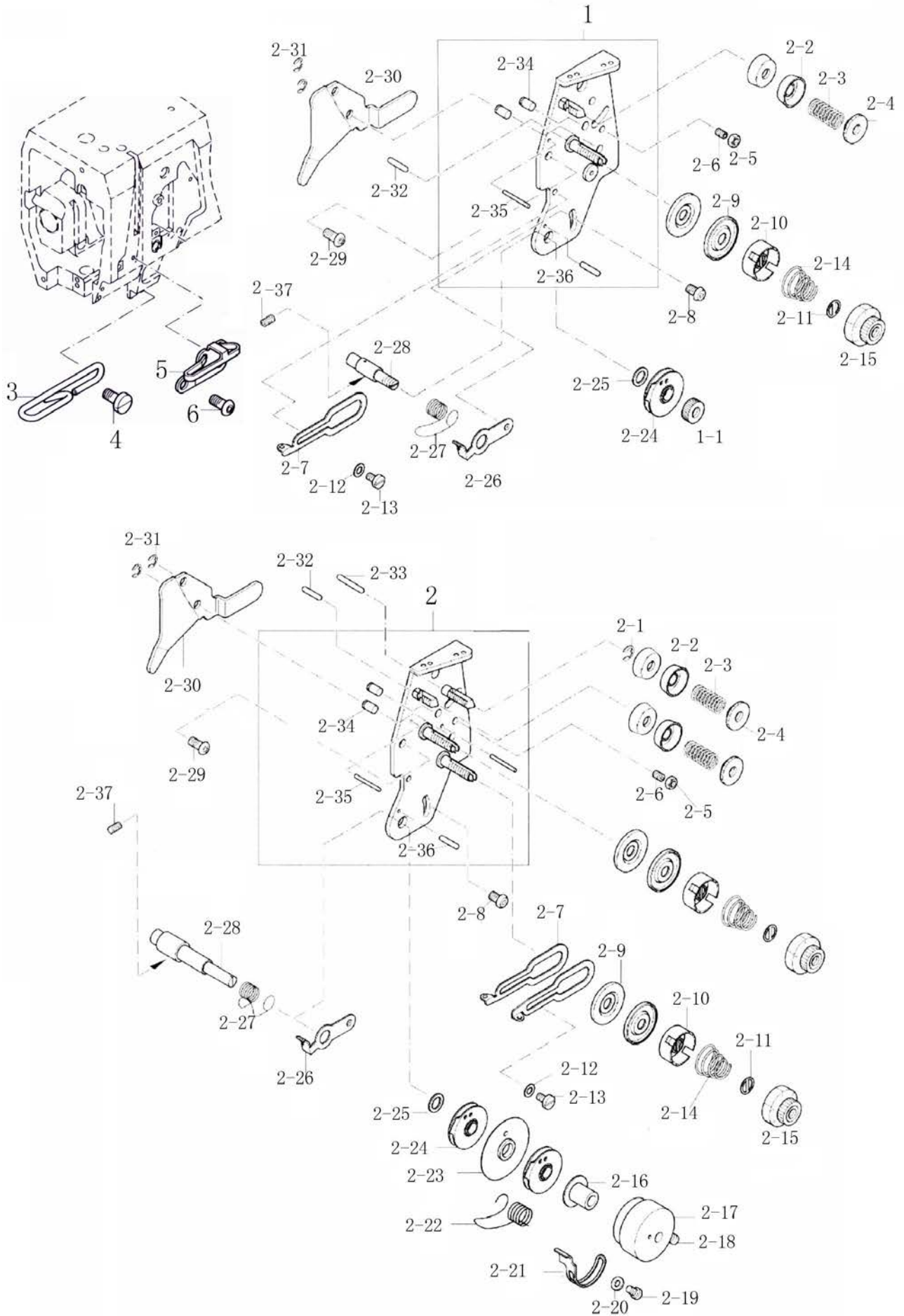

### E. Main shaft driving parts

No.	Part No.	Name	1 Needle	2 Needle
1	7.02.01.358	Cam	1	1
2	7.02.15.014	Cam set screw	1	1
3	7.02.15.013	Cam set screw	1	1
4	7.02.15.053	Screw	1	1
5	7.02.15.050	Set screw	1	1
6	7.02.09.004	Upper shaft bushing	1	1
7	7.02.04.008	Bearing	1	1
8	7.02.03.330	Upper shaft	1	1
9	7.02.07.262	Thread winder driven wheel	1	1
10	7.02.15.057	Driven wheel screw	2	2
11	7.02.07.003	Timing belt (Upper)	1	1
12	7.02.07.266	Timing belt wheel (Upper)	1	1
13	7.02.15.050	Set screw	3	3
14	7.02.07.002	Timing belt wheel (Middle)	2	2
15	7.02.15.051	Fixing screw	3	3
16	7.02.15.050	Set screw	3	3
17	7.02.16.415	Elastic component of clutch	1	1
18	7.02.08.473	Coupling	1	1
19	7.02.04.152	Bearing	1	1
20	7.02.19.343	Direct driven motor	1	1
21	7.02.15.445	Mounting screw	4	4
22	7.02.04.007	Bearing	1	1
23	7.02.08.003	Upper shaft bushing	1	1
24	7.02.15.050	Set screw	2	2
25	7.02.09.00502	Stitch length indicating ring	1	
	7.02.09.01002	Stitch length indicating ring		1
26	7.02.07.00101	Belt pulley	1	1
27	7.02.15.052	Belt pulley fixing screw	1	1
28	7.02.15.064	Belt pulley set screw	1	1
29	7.02.18.001	Spacer	1	1
30	7.02.15.016	Screw	1	1
31	7.02.18.120	Wave shape washer	1	1
32	7.02.19.012	Magnetic block	2	2
33	7.02.11.083	Stopper needle fixed plate	1	
34	7.02.03.332	Pulley shaft	1	1
35	7.02.04.012	Bearing	1	1
36	7.02.18.020	Elastic stop ring	1	1



## E. Main shaft driving parts

---

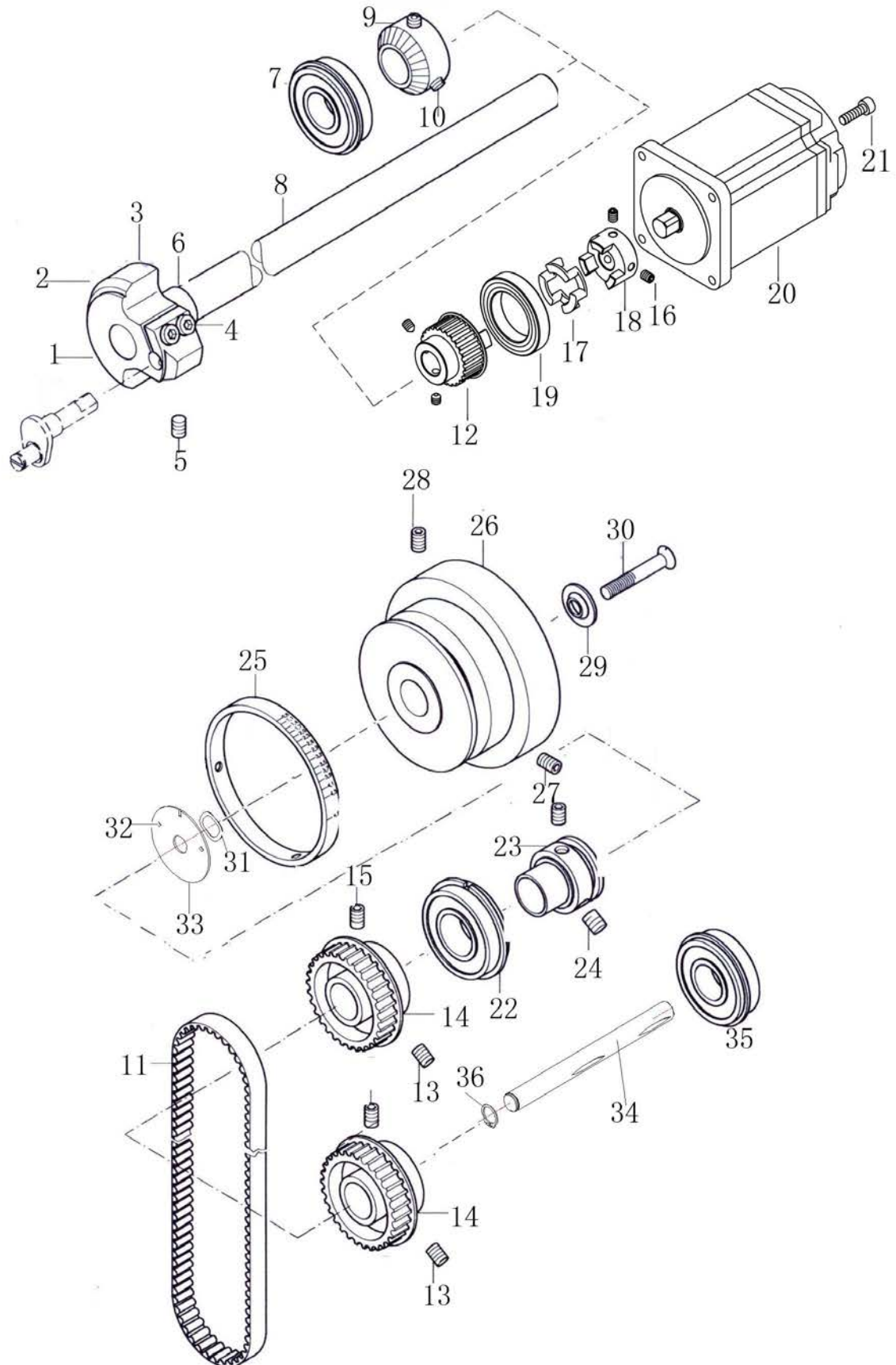



# F. Upper side shaft feed parts

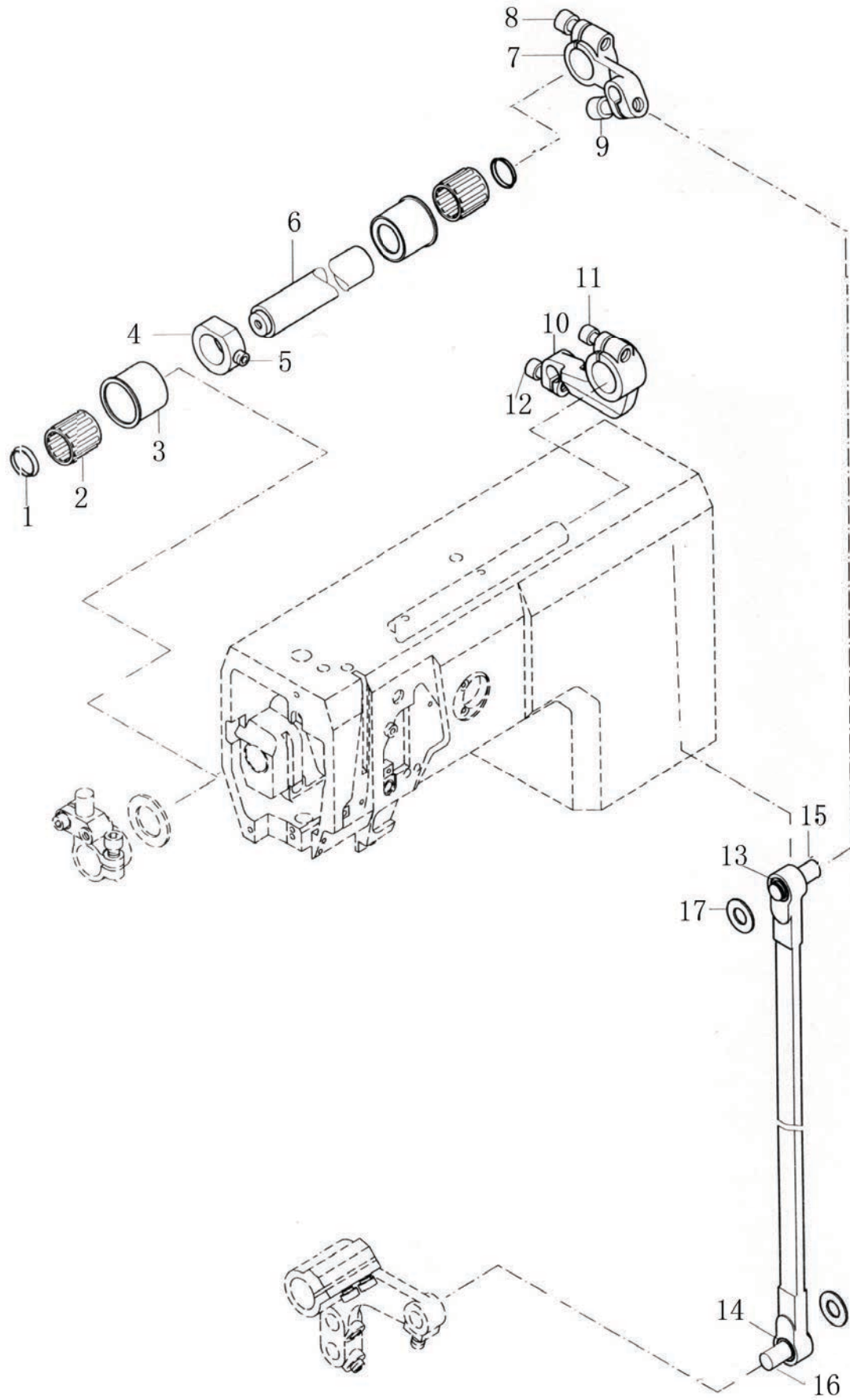



# G. Presser foot lifting parts

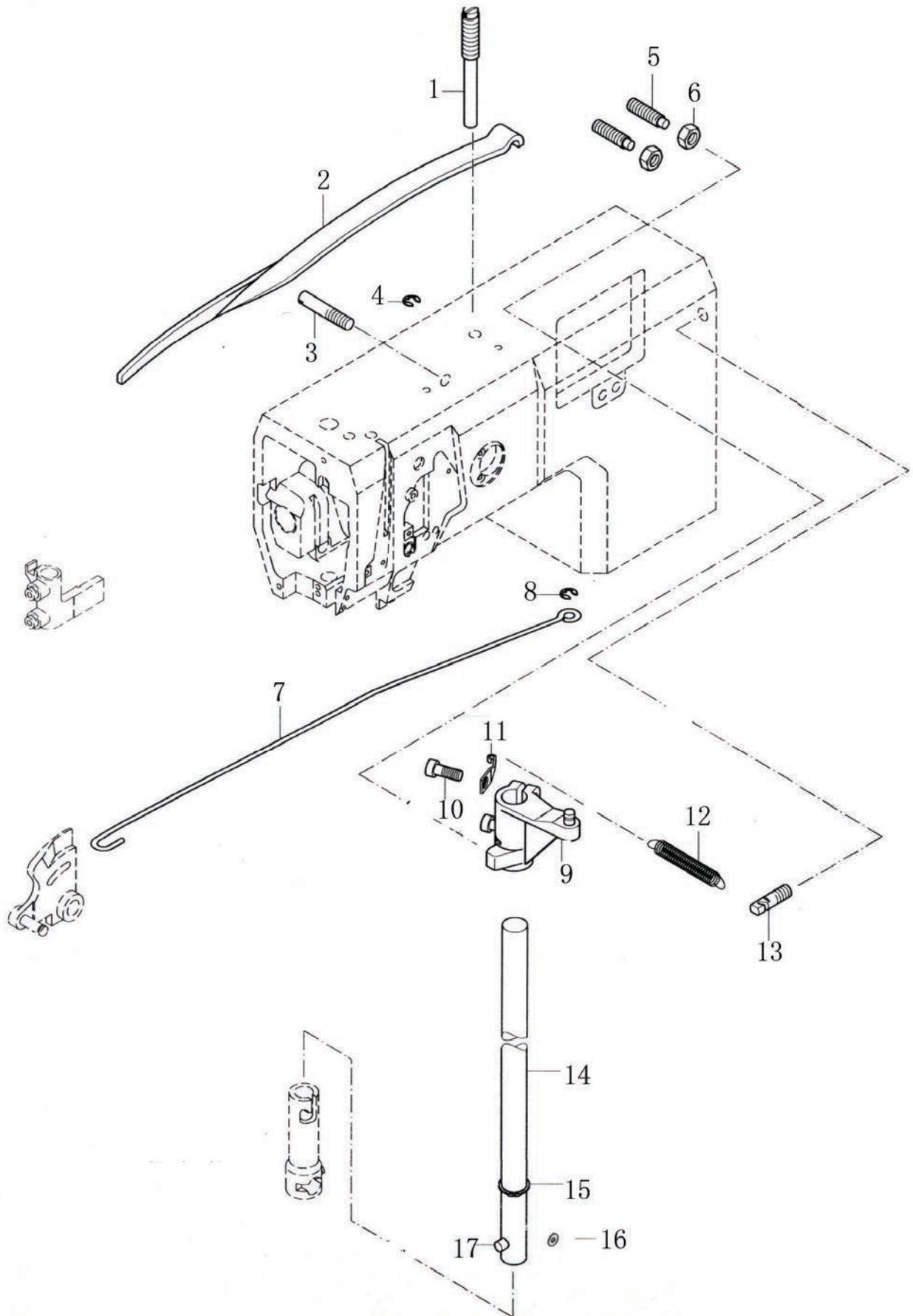



# H. Bobbin winder parts

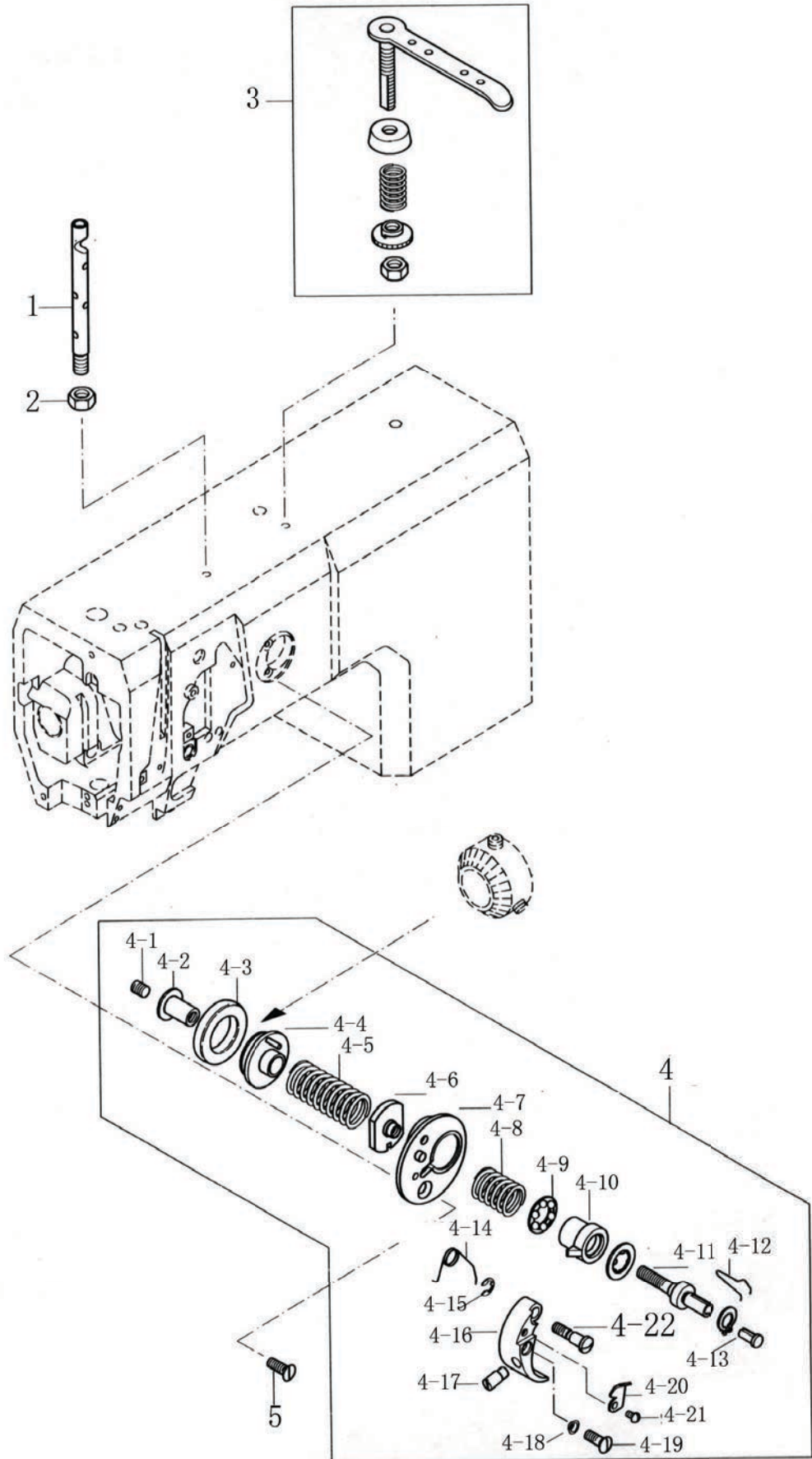





# I. Stitch length adjustment parts

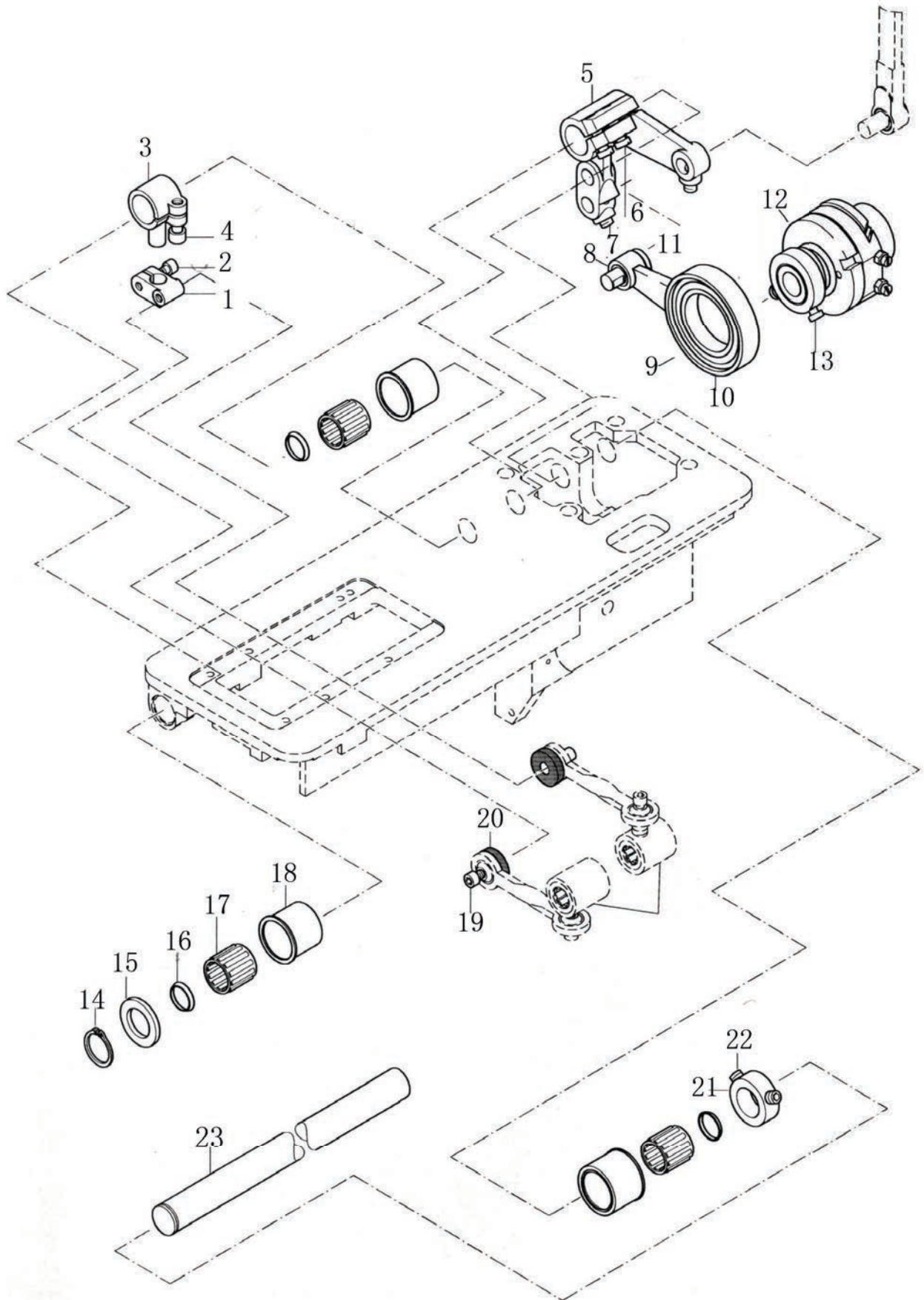



# J. Clutch set parts

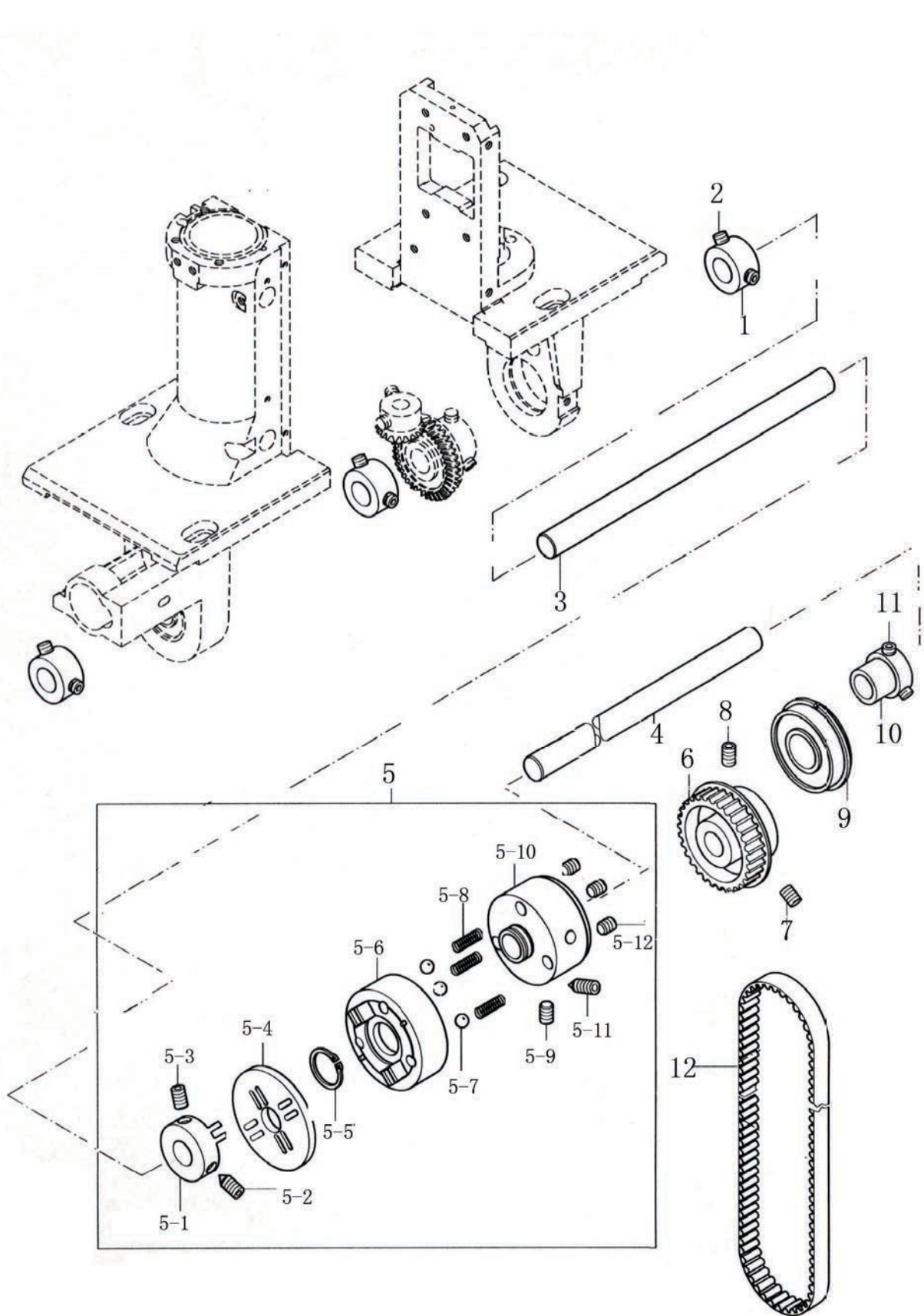



# K. Oil lubrication parts

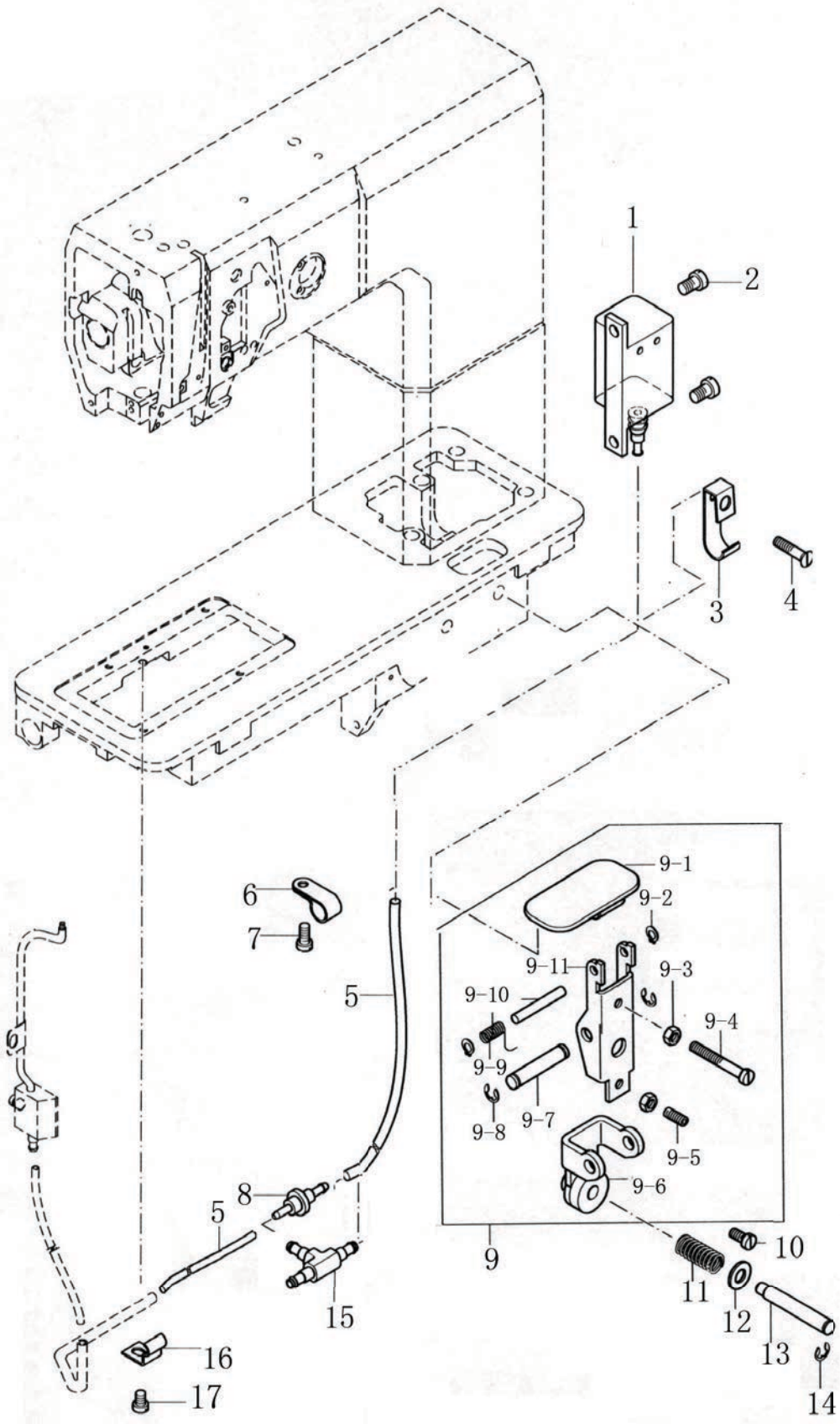

## L. Hook parts (Left)

No.	Part No.	Name	1 Needle	2 Needle
1	7.02.01.285	Hook assy.		1
1-1		Bobbin case		1
1-2		Elastic gasket		1
1-3		Screw		3
1-4		Screw		1
1-5		Needle guard slice		1
1-6		Screw		2
2	7.02.15.038	Screw		1
3	7.02.21.385	Bobbin		1
4	7.02.15.047	Screw		2
5	7.02.07.205	Driven gear		1
6	7.02.15.799	Screw (Long)		1
7	7.02.20.051	Thread trimming clamp plate		1
8	7.02.15.801	Screw		1
9	7.02.20.052	Movable knife		1
10	7.02.15.973	Screw		1
11	7.02.03.342	Driven shaft		1
12	7.02.10.458	Eccentric pin		1
13	7.02.15.433	Screw		1
14	7.02.20.050	Fixed knife		1
15	7.02.15.063	Screw (Short)		1
16	7.02.01.352	Movable knife bracket		1
17	7.02.10.370	Position pin		1
18	7.02.04.019	Bearing		1
19	7.02.04.018	Needle bearing		1
20	7.02.07.206	Gear		1
21	7.02.15.054	Screw		1
22	7.02.15.247	Set screw		2
23	7.02.18.255	Elastic retaining ring		1
24	7.02.18.256	Washer		1
25	7.02.11.386	Oil guard plate		1
26	7.02.08.027	Bushing		1
27	7.02.04.113	Bearing		1
28	7.02.18.257	Washer		1
29	7.02.04.020	Bearing		2
30	7.02.01.356	Bushing		1
31	7.02.04.009	Needle bearing		1
32	7.02.01.288	Thread distributing claw		1
33	7.02.15.420	Screw		1
34	7.02.01.289	Thread distributing claw bracket		1
35	7.02.16.300	Seal ring		1
36	7.02.11.385	Oil supply plate		1
37	7.02.15.577	Screw		1
38	7.02.16.303	Oil supply valve		1
39	7.02.15.022	Screw		1
40	7.02.16.047	Oil tube		1
41	7.02.16.309	Copper oil tube		1
42	7.02.03.340	Shaft		1

L. Hook parts (Left)

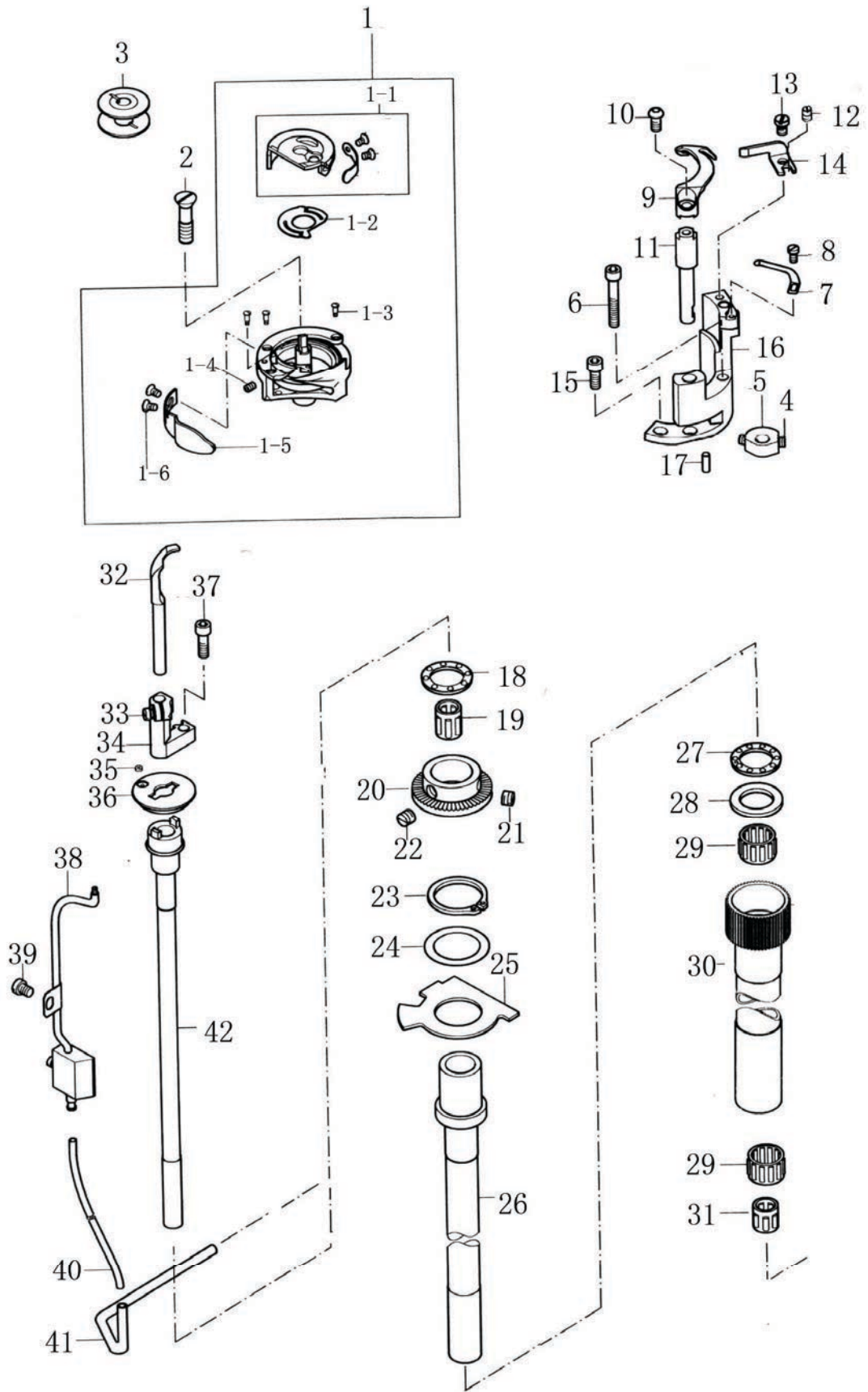





# M. Left side bracket parts

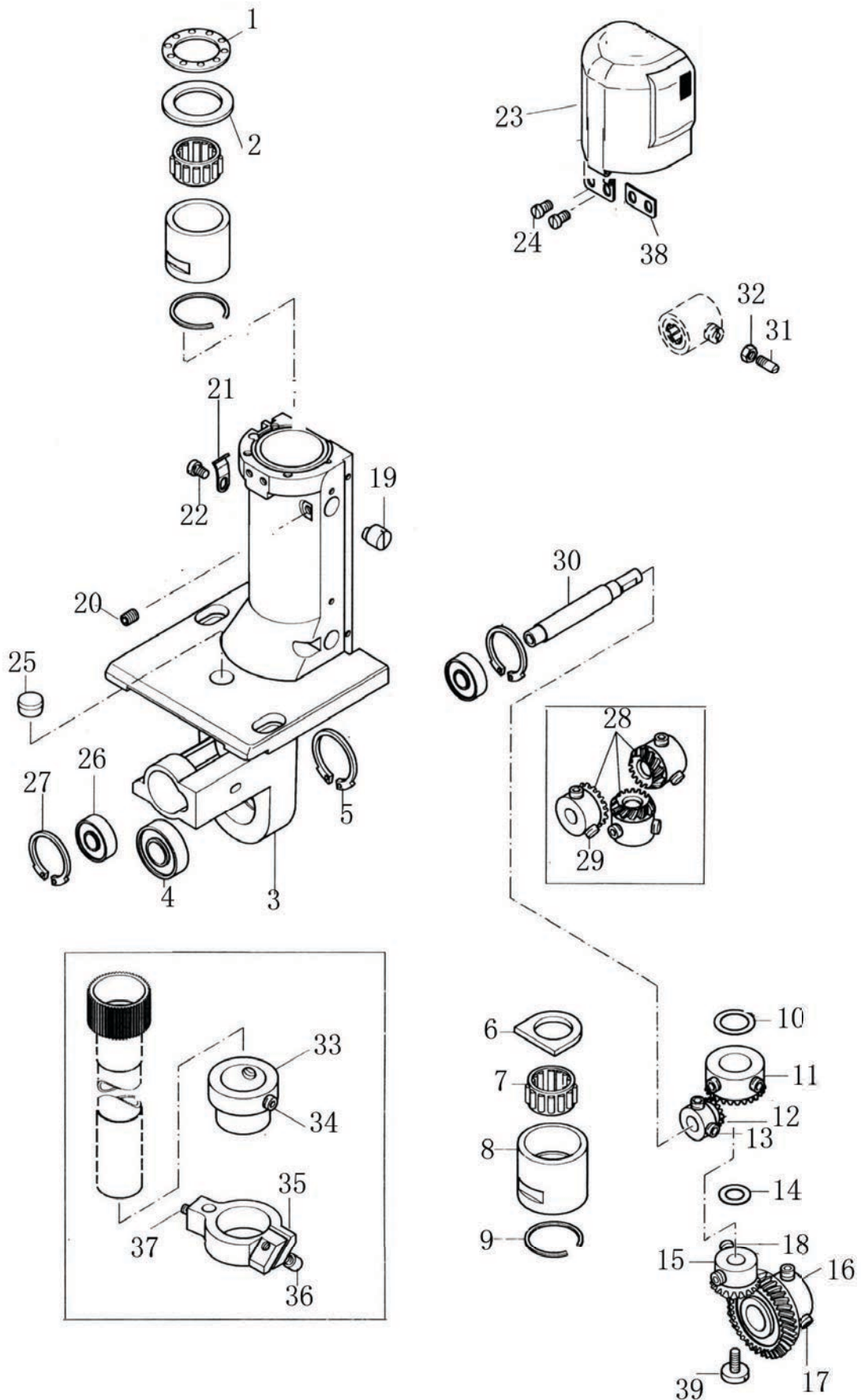

### N. Hook thread parts ( Right )

No.	Part No.	Name	1 Needle	2 Needle
1	7.02.01.285	Hook assy.	1	1
1-1		Bobbin case	1	1
1-2		Elastic gasket	1	1
1-3		Screw	3	3
1-4		Screw	1	1
1-5		Needle guard slice	1	1
1-6		Screw	2	2
2	7.02.15.038	Screw	1	1
3	7.02.21.385	Bobbin	1	1
4	7.02.15.047	Screw	2	2
5	7.02.07.205	Driven gear	1	1
6	7.02.15.799	Screw (Long)	1	1
7	7.02.20.051	Thread trimming clamp plate	1	1
8	7.02.15.801	Screw	1	1
9	7.02.20.052	Movable knife	1	1
10	7.02.15.973	Screw	1	1
11	7.02.03.342	Driven shaft	1	1
12	7.02.10.458	Eccentric pin	1	1
13	7.02.15.433	Screw	1	1
14	7.02.20.050	Fixed knife	1	1
15	7.02.15.063	Screw (Short)	1	1
16	7.02.01.352	Movable knife bracket	1	1
17	7.02.10.370	Position pin	1	1
18	7.02.04.019	Bearing	1	1
19	7.02.04.018	Needle bearing	2	2
21	7.02.16.303	Oil supply valve	1	1
22	7.02.15.022	Screw	1	1
23	7.02.16.047	Oil tube	1	1
24	7.02.03.340	Shaft	1	1
25	7.02.11.385	Oil supply plate	1	1
26	7.02.16.300	Seal ring	1	1
27	7.02.01.289	Thread distributing claw bracket	1	1
28	7.02.15.420	Screw	1	1
29	7.02.01.288	Thread distributing claw	1	1
30	7.02.15.577	Screw	1	1

N. Hook thread parts (Right)

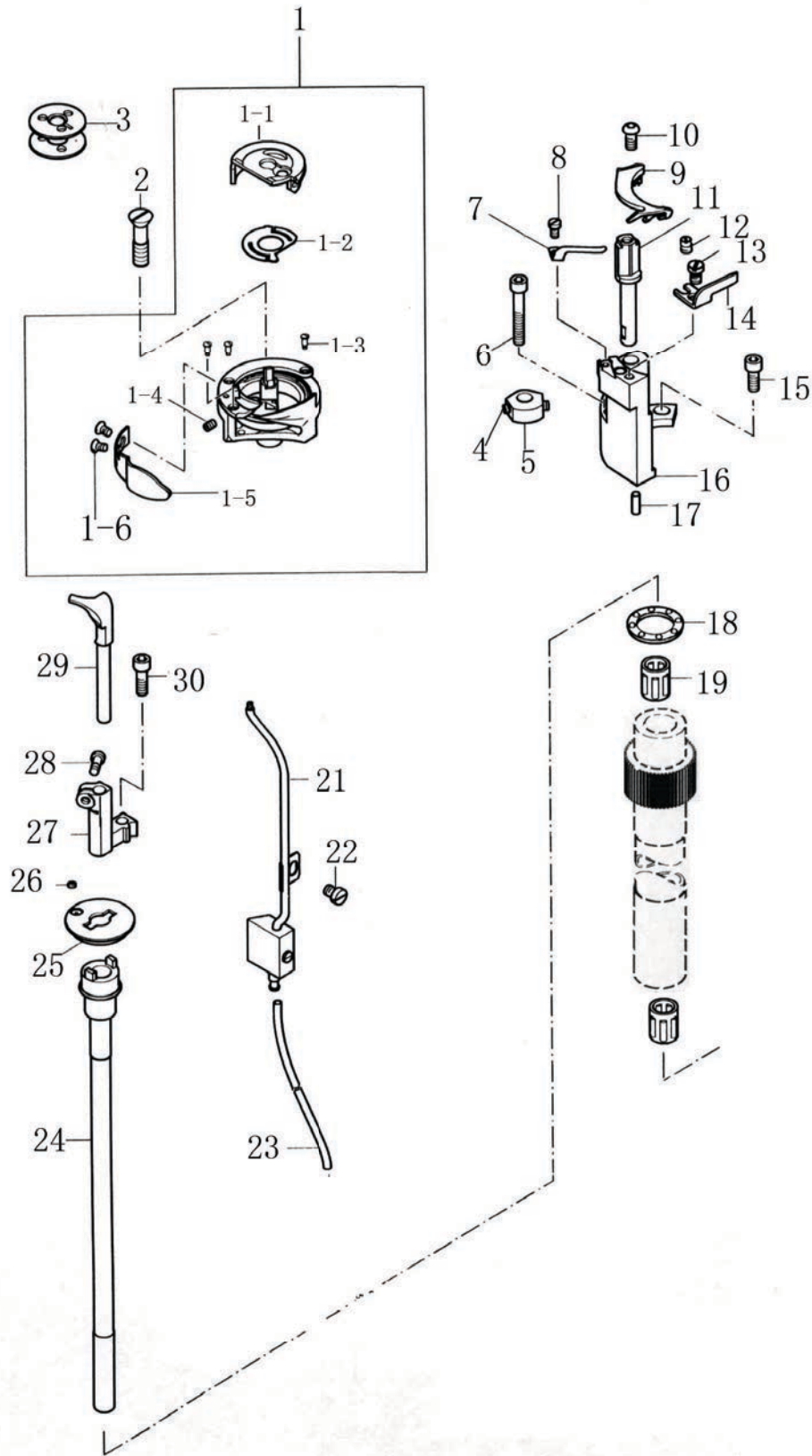

## O. Right side bracket parts

No.	Part No.	Name	1 Needle	2 Needle
1	7.02.18.251	Elastic retaining ring	1	1
2	7.02.18.252	Washer	1	1
3	7.02.11.386	Oil guard plate	1	1
4	7.02.08.392	Bushing	1	1
5	7.02.09.080	Bushing collar	1	1
6	7.02.15.054	Screw	2	2
7	7.02.06.279	Thread trimming crank	1	1
8	7.02.15.056	Crank screw	1	1
9	7.02.15.063	Set screw	1	1
10	7.02.04.111	Bearing	1	1
11	7.02.18.253	Washer	1	1
12	7.02.17.350	Spring plate	1	1
13	7.02.15.433	Screw	1	1
14	7.02.13.29001	Side bracket (Right)	1	1
15	7.02.04.110	Ball bearing	1	1
16	7.02.18.250	Elastic retaining ring	1	1
17	7.02.16.301	Oil felt	1	1
18	7.02.04.112	Needle bearing	2	2
19	7.02.08.393	Bushing	1	1
20	7.02.18.254	Elastic retaining ring	1	1
21	7.02.09.115	Washer	1	1
22	7.02.15.054	Screw	2	2
23	7.02.07.011	Gear (Small)	1	1
24	7.02.07.012	Gear (Large)	1	1
25	7.02.15.050	Screw	2	2
26	7.02.15.054	Screw	2	2
27	7.02.11.384	Cover plate	1	
	7.02.11.486	Cover plate	1	
	7.02.11.485	Cover plate		2
28	7.02.15.973	Cover plate screw	8	10
29	7.02.18.003	Washer	2	2
30	7.02.15.965	Screw	2	2
31	7.02.10.011	Adjusting pin	1	1
32	7.02.15.035	Adjusting pin set screw	1	1
33	7.02.02.391	Post cap assy.	1	1
34	7.02.15.005	Set screw	2	4
35	7.02.02.502	Needle plate Small hole		1
36	7.02.15.032	Needle plate screw		2
37	7.02.13.29101	Support plate		1
38	7.02.15.006	Support plate screw		4
39	7.02.07.013	Feed wheel		1
40	7.02.17.002	Feed wheel position plate		1
41	7.02.15.017	Feed wheel position plate screw		2

# O. Right side bracket parts

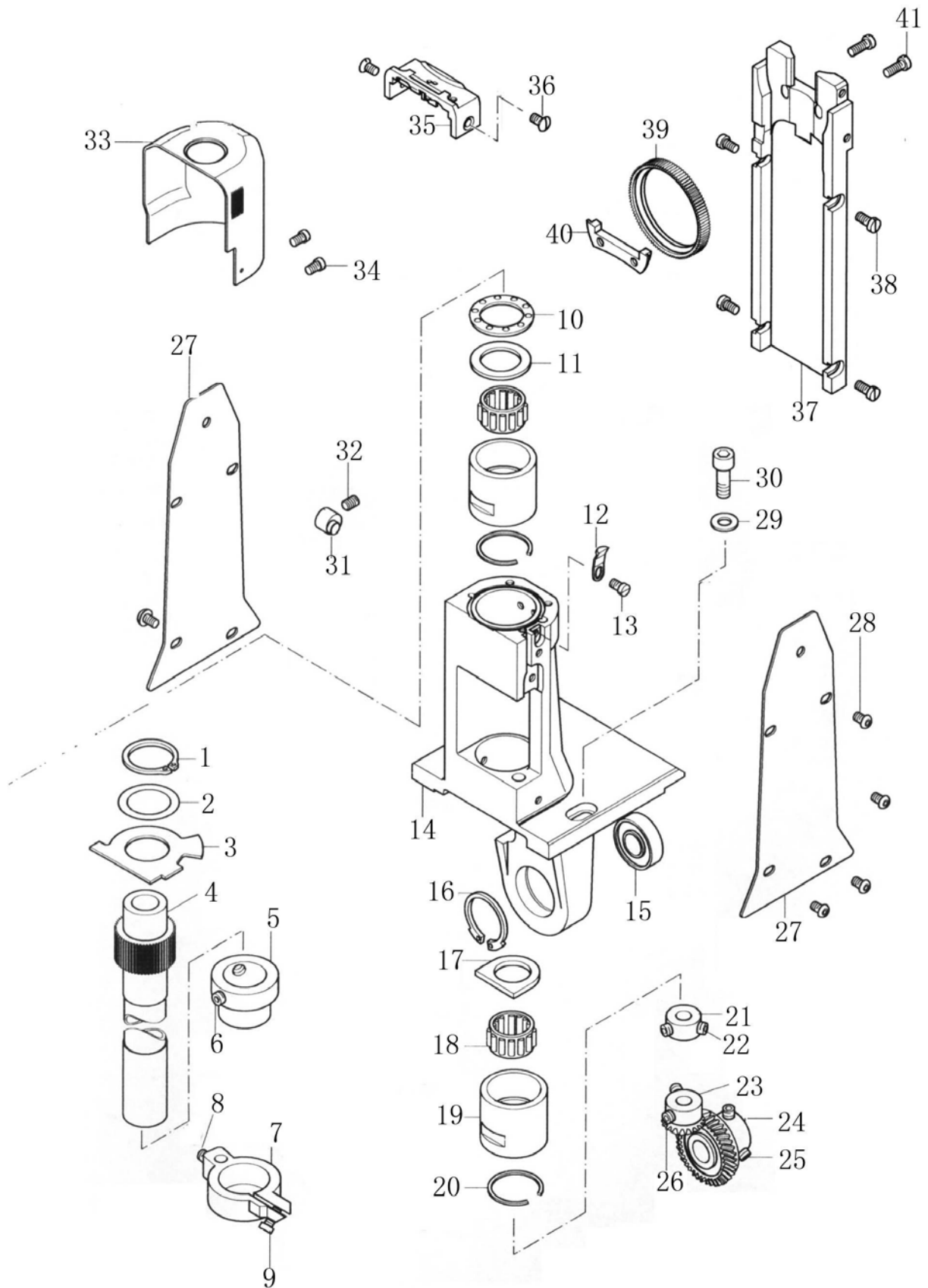

P. Bed plate feed parts

No.	Part No.	Name	1 Needle	2 Needle
1	7.02.02.397	Needle plate	1	
2	7.02.15.032	Needle plate screw	2	
3	7.02.15.965	Screw	2	
4	7.02.18.003	Washer	2	
5	7.02.13.28901	Support plate	1	
6	7.02.15.053	Screw	2	
7	7.02.18.016	Washer	2	
8	7.02.15.030	Screw	1	
9	7.02.10.010	Adjusting pin	1	
10	7.02.15.031	Adjusting pin set screw	1	
11	7.02.16.409	Plastic plug	1	
12	7.02.04.110	Ball bearing	1	
13	7.02.18.250	Elastic retaining ring	1	
14	7.02.04.016	Ball bearing	1	
15		Washer	1	
16	7.02.18.027	Elastic retaining ring	1	
17	7.02.08.017	Free-wheeling seat	2	
18	7.02.04.001	Needle bearing	2	
19	7.02.16.010	Oil felt	4	
20	7.02.05.001	Link	2	
21	7.02.15.040	Screw	4	
22	7.02.03.425	Shaft	1	
23	7.02.07.009	Bevel gear (Small)	2	
24	7.02.07.170	Bevel gear (Medium)	1	
25	7.02.15.054	Screw	4	
26	7.02.15.050	Screw	2	
27	7.02.08.035	Bushing	2	
28	7.02.15.049	Screw	2	
29	7.02.03.019	Shaft	1	
30	7.02.08.016	Bushing	2	
31	7.02.15.036	Screw	6	
32	7.02.16.004	Plastic joint	1	
33	7.02.08.015	Bushing	1	
34	7.02.09.002	Collar	1	
35	7.02.13.002	Bracket	1	
36	7.02.15.035	Screw	1	
37	7.02.15.061	Screw	2	
38	7.02.07.006	Feed wheel	1	
39	7.02.07.008	Bevel gear (Lower)	1	
40	7.02.07.007	Bevel gear (Upper)	1	
41	7.02.10.004	Roller bracket (Upper)	1	
42	7.02.10.002	Roller bracket (Lower)	1	
43	7.02.04.021	Ball (φ2)	24	
44	7.02.15.034	Screw	3	

# P. Bed plate feed parts

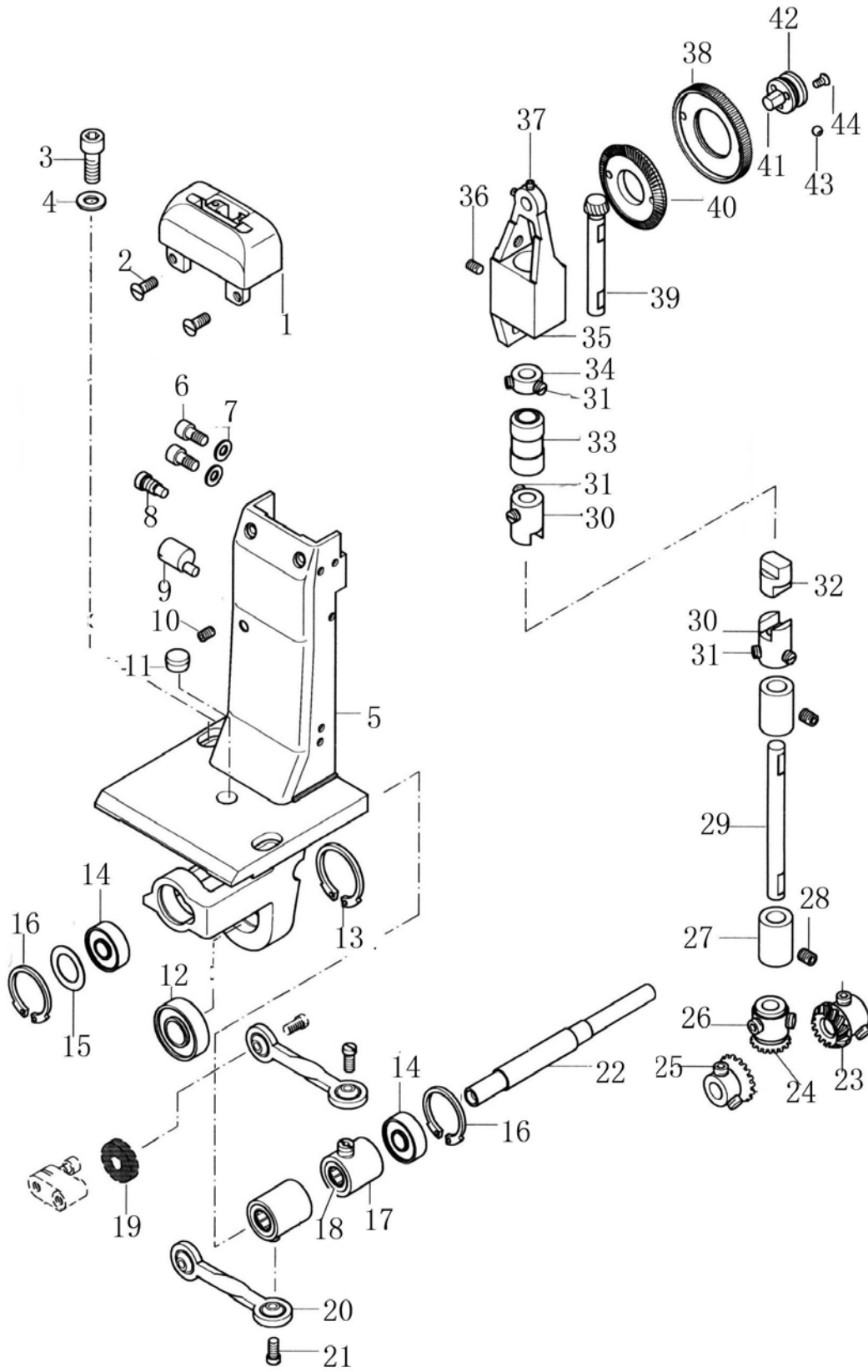





Q. Solenoid for thread trimming parts

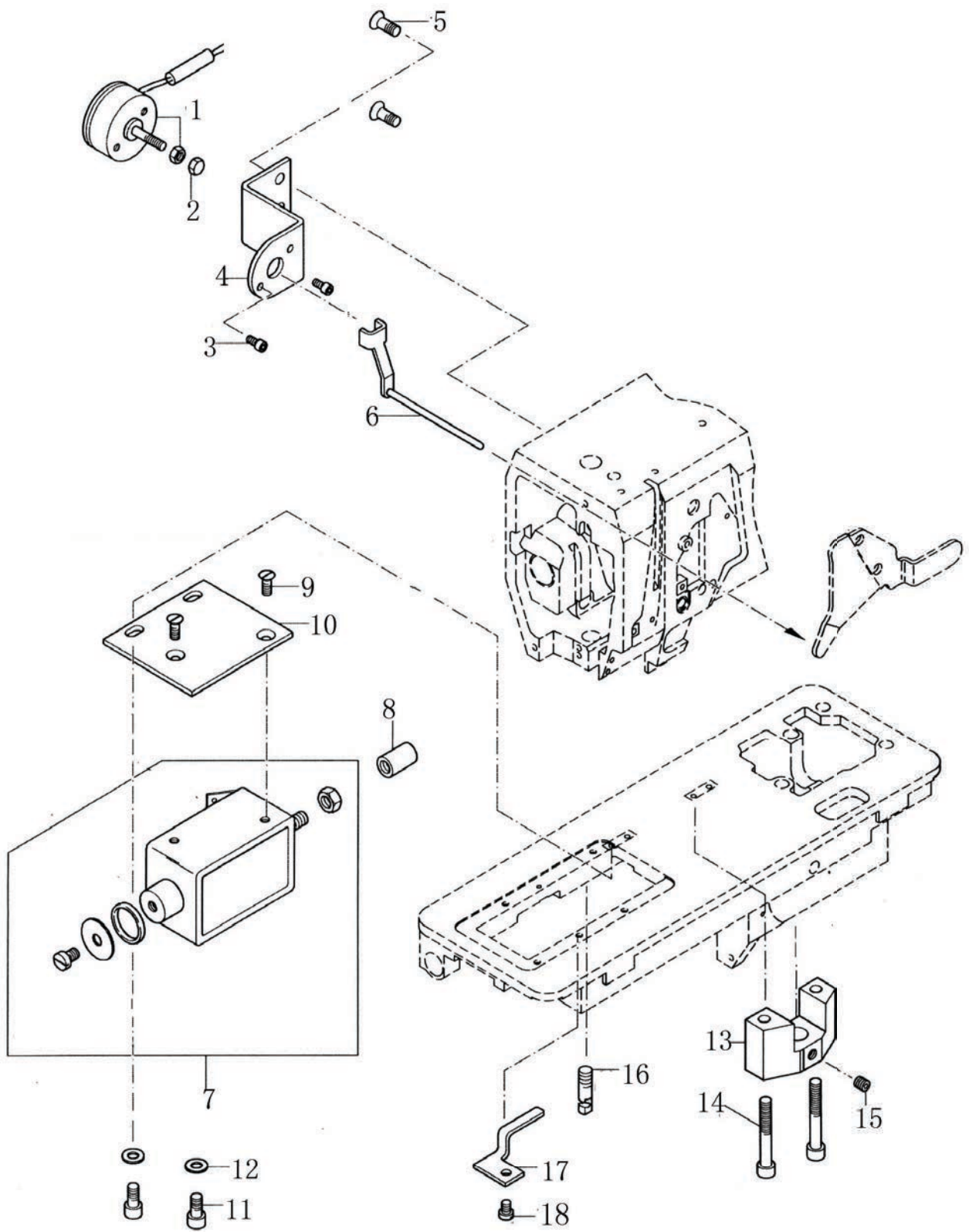



# R. Thread trimming driving parts

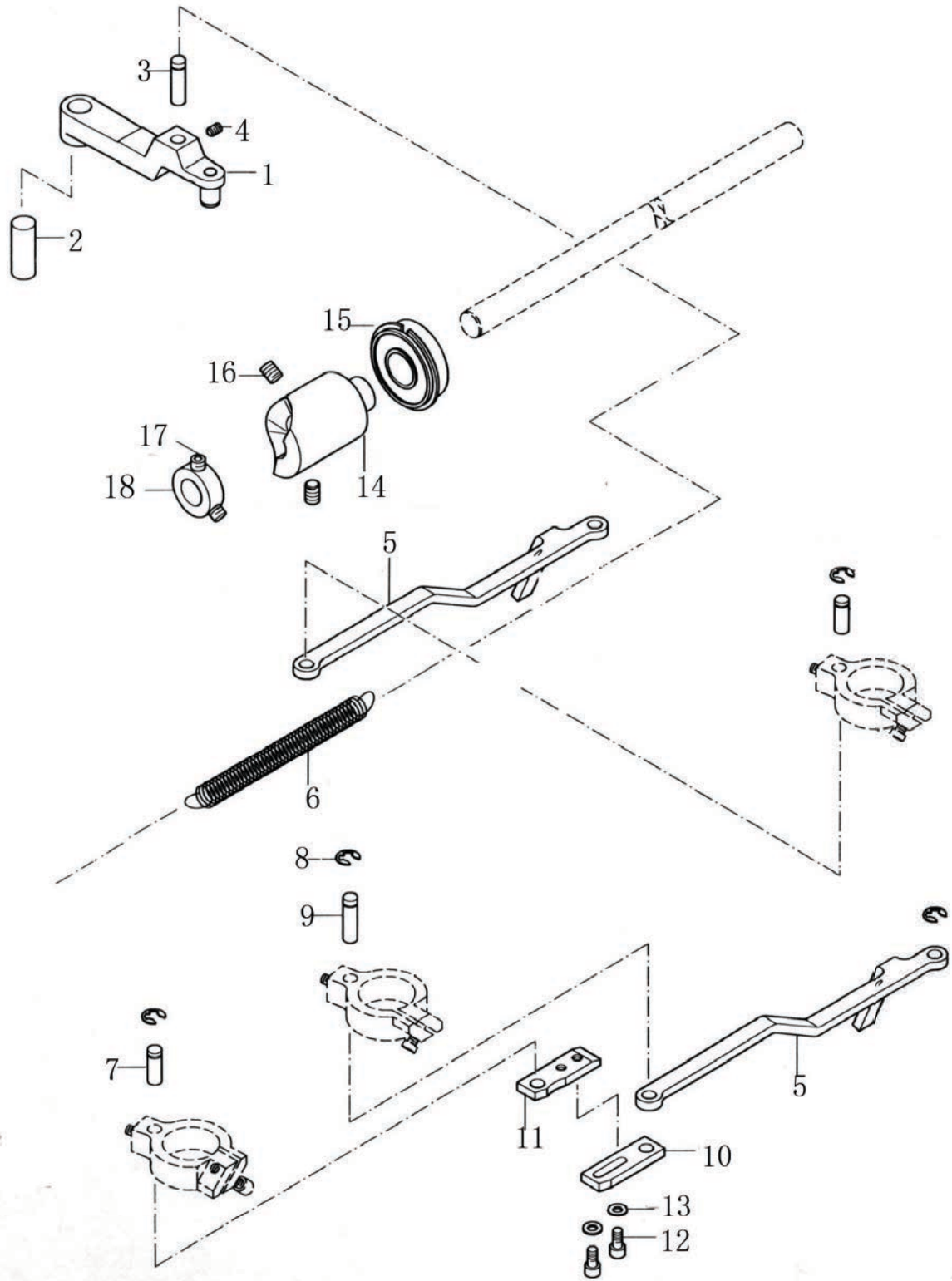



# S. Solenoid for presser foot lifting parts

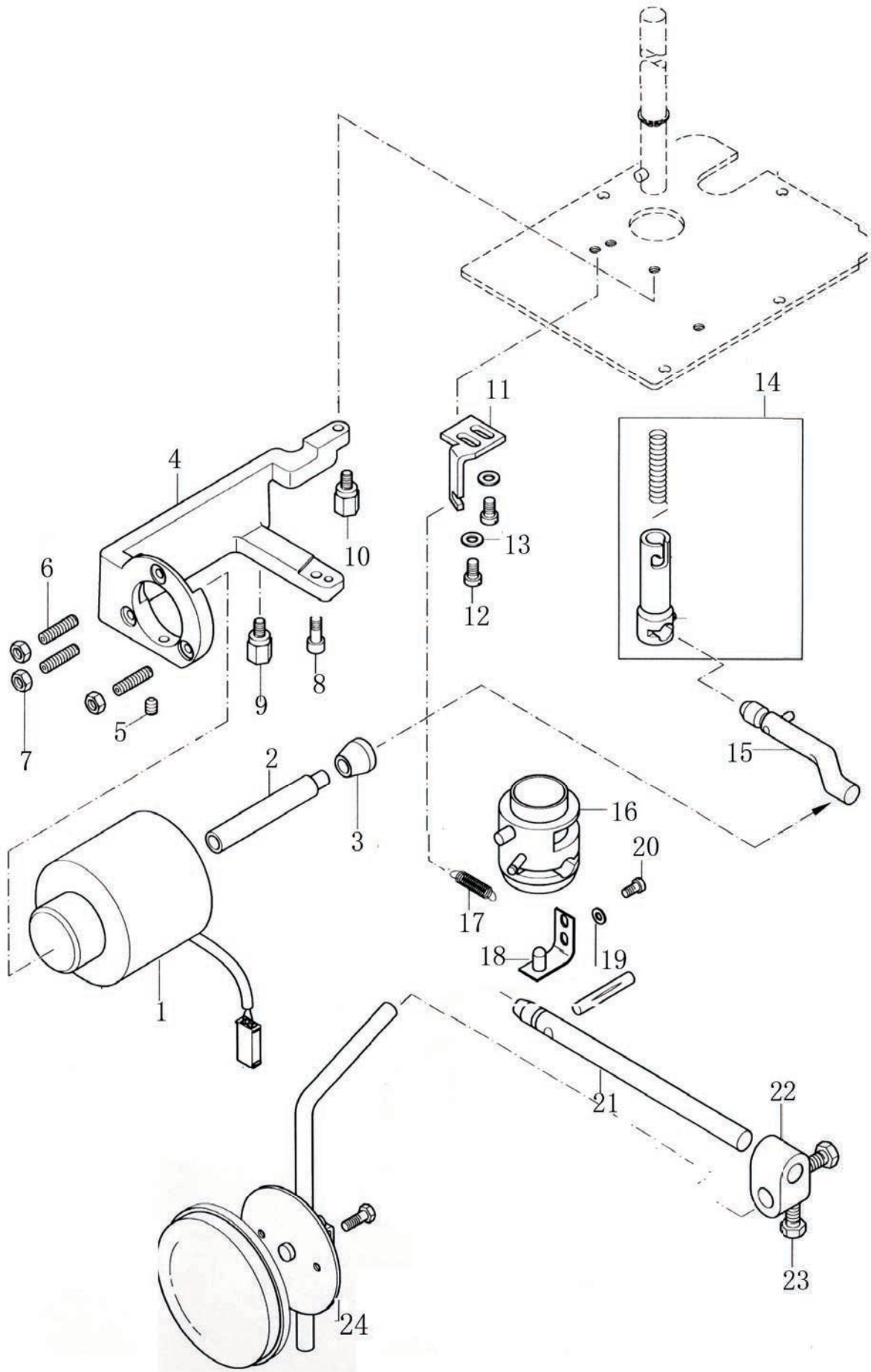

## T. Upper feed and backstitch parts

No.	Part No.	Name	1 Needle	2 Needle
1	7.02.19.347	Backtack solenoid (Upper)	1	1
2	7.02.17.417	Spring	1	1
3	7.02.18.330	Washer	1	1
4	7.02.18.223	Elastic retaining ring	1	1
5	7.02.05.449	Solenoid joint	1	1
6	7.02.10.455	Pin	1	1
7	7.02.13.377	Solenoid bracket	1	1
8	7.02.15.555	Solenoid fixed screw	2	2
9	7.02.10.453	Shaft	1	1
10	7.02.05.444	Crank (Front)	1	1
11	7.02.05.443	Crank (Back)	1	1
12	7.02.15.803	Screw	2	2
13	7.02.08.471	Shaft joint	1	1
14	7.02.10.454	Pin	1	1
15	7.02.04.002	Bearing	1	1
16	7.02.18.025	Elastic retaining ring	2	2
17	7.02.15.445	Screw	2	2
18	7.02.08.006	Connecting holder	1	1
19	7.02.15.017	Screw	1	1
20	7.02.08.005	Crank	1	1
21	7.02.15.053	Screw	1	1
22	7.02.05.001	Link	2	2
23	7.02.15.010	Screw	4	4
24	7.02.16.010	Oil felt	4	4
25	7.02.09.116	Washer	1	1
26	7.02.17.321	Spring	1	1
27	7.02.18.005	Washer	4	4
28	7.02.18.028	E type ring	4	4
29	7.02.04.001	Needle bearing	2	2
30	7.02.08.001	Free-wheeling seat	2	2
31	7.02.10.262	Pin	1	1
32	7.02.03.423	Shaft	1	1
33	7.02.07.267	Castle wheel (Upper)	1	1
34	7.02.07.268	Castle wheel (Lower)	1	1
35	7.02.15.056	Screw	2	2
36	7.02.02.390	Roller presser foot	1	1
37	7.02.05.002	Connecting holder	1	1
38	7.02.15.011	Screw	1	1
39	7.02.15.011	Washer	1	1

# T. Upper feed and backstitch parts

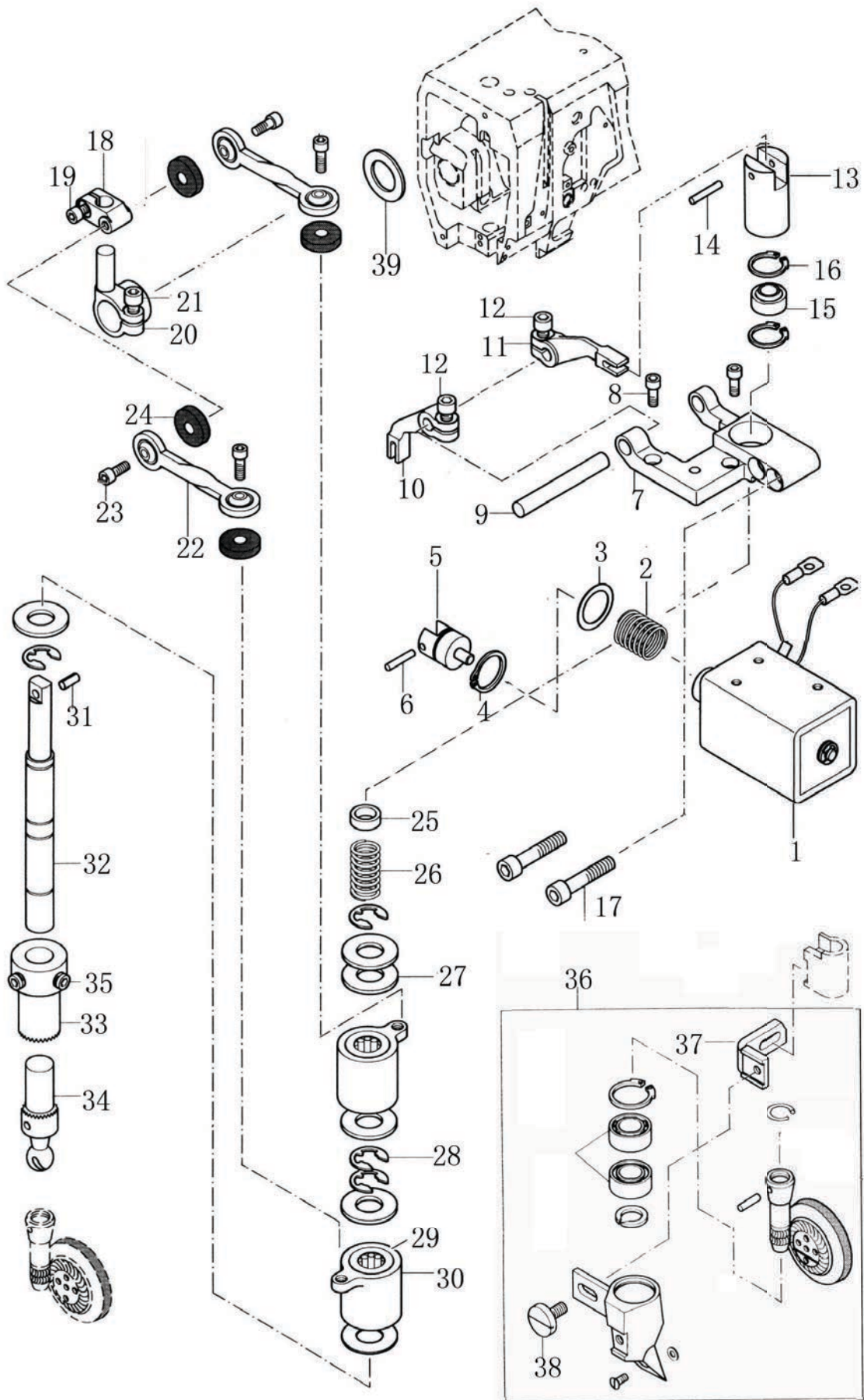





# U.Lower feed and backstitch parts for single needle

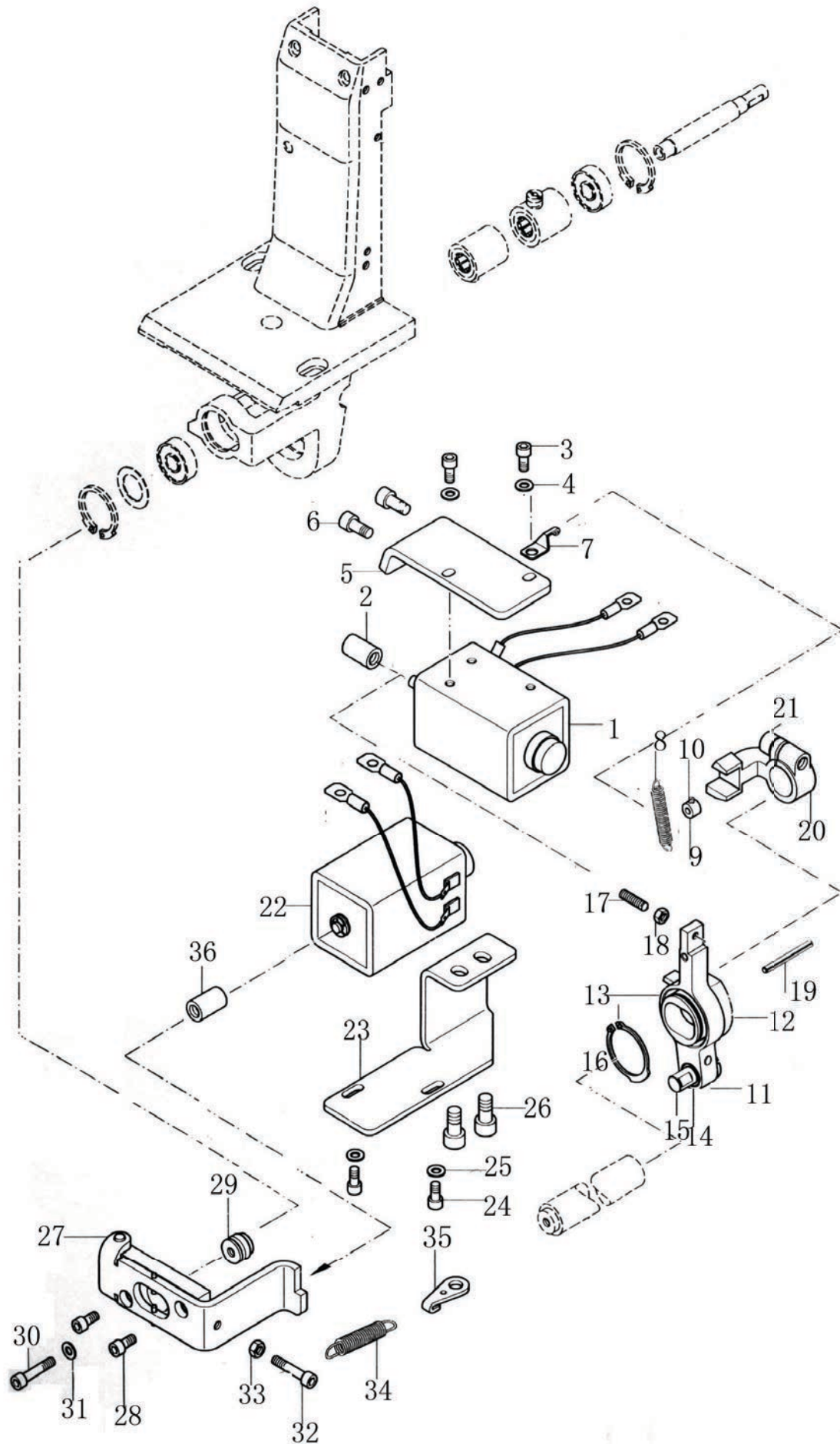

V. Lower feed and backstitch parts for double needle

No.	Part No.	Name	1 Needle	2 Needle
1	7.02.01.355	Gear holder assy.		1
1-1		Fitting bracket		1
1-2	7.02.11.489	Stopper plate		1
1-3	7.02.15.063	Screw		2
1-4		Pin		1
1-5		Spring		2
1-6		Pin		1
1-7		Screw		1
1-8		Screw		1
1-9		Nut		1
1-10		Shaft		1
1-11		Gear seat		1
1-12	7.02.11.505	Connecting plate		1
1-13	7.02.15.432	Screw		2
2	7.02.15.048	Screw		1
3	7.02.03.426	Shaft		1
4	7.02.04.016	Ball bearing		1
5		Washer		1
6	7.02.18.027	Elastic retaining ring		1
7	7.02.08.017	Free-wheeling		2
8	7.02.04.001	Needle bearing		2
9	7.02.05.446	Link		1
10	7.02.15.040	Screw		1
11	7.02.18.071	Washer		1
12	7.02.15.010	Screw		2
13	7.02.16.010	Oil felt		2
14	7.02.15.555	Screw		3
15	7.02.18.071	Washer		4
16	7.02.11.490	Fitting plate		1
17	7.02.15.803	Screw		4
18	7.02.11.491	Fixed plate		1
19	7.02.19.349	Backtack solenoid (Lower)		1
20	7.02.15.978	Screw		1
21	7.02.05.447	Crank		1
22	7.02.13.378	Bracket		1

# V. Lower feed and backstitch parts for double needle

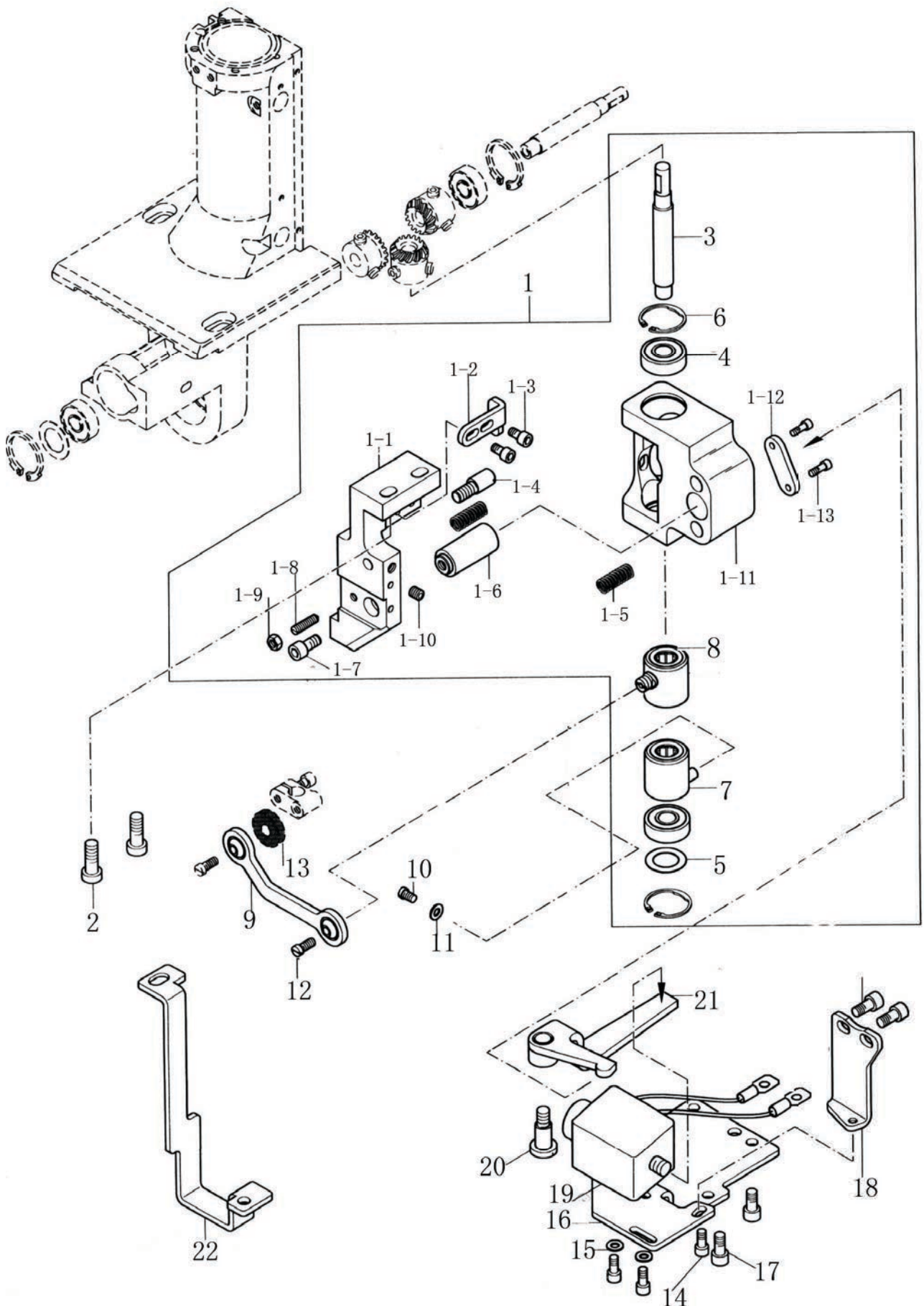



W. Power cable connection

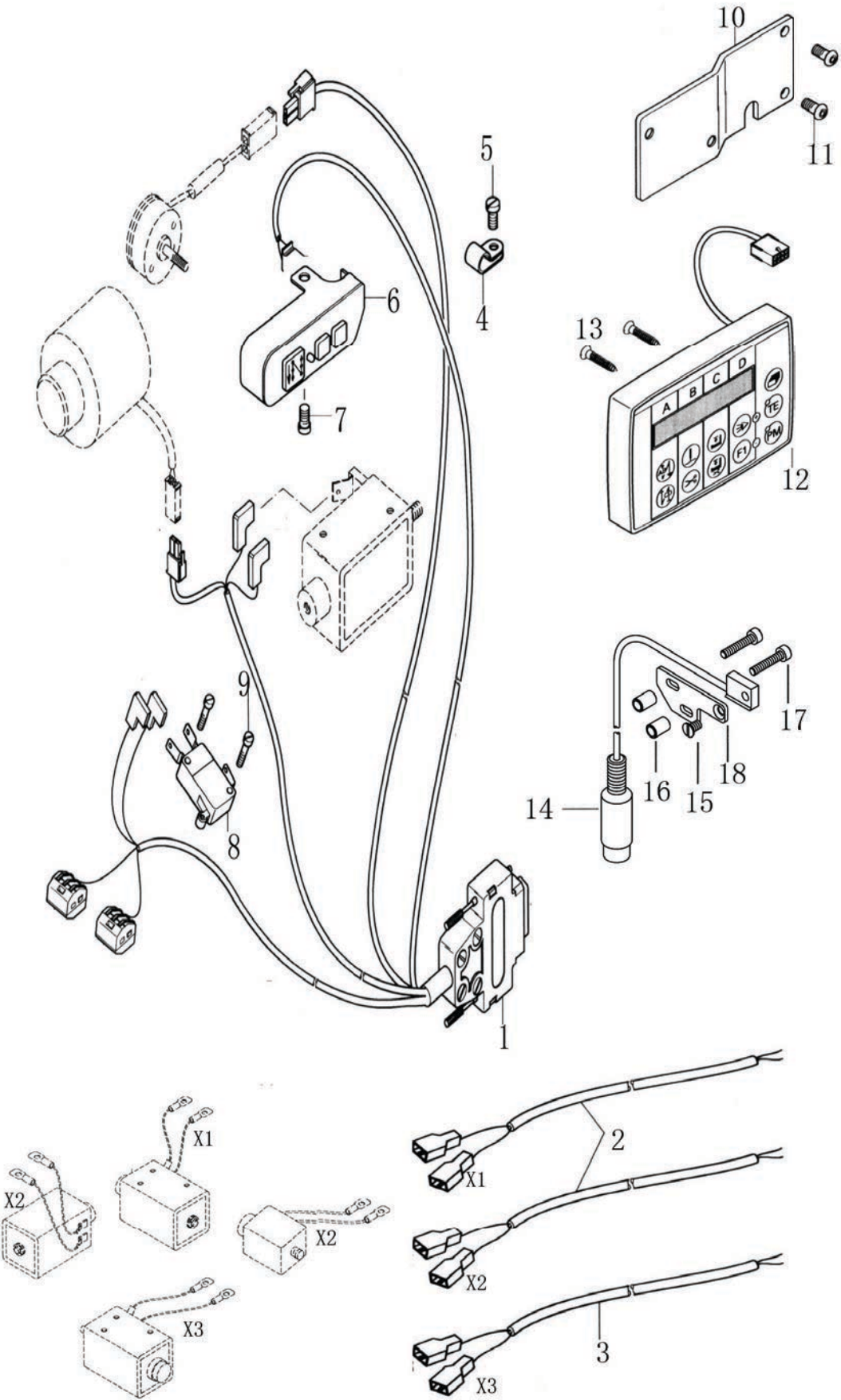



# X. Parts of integrated machine

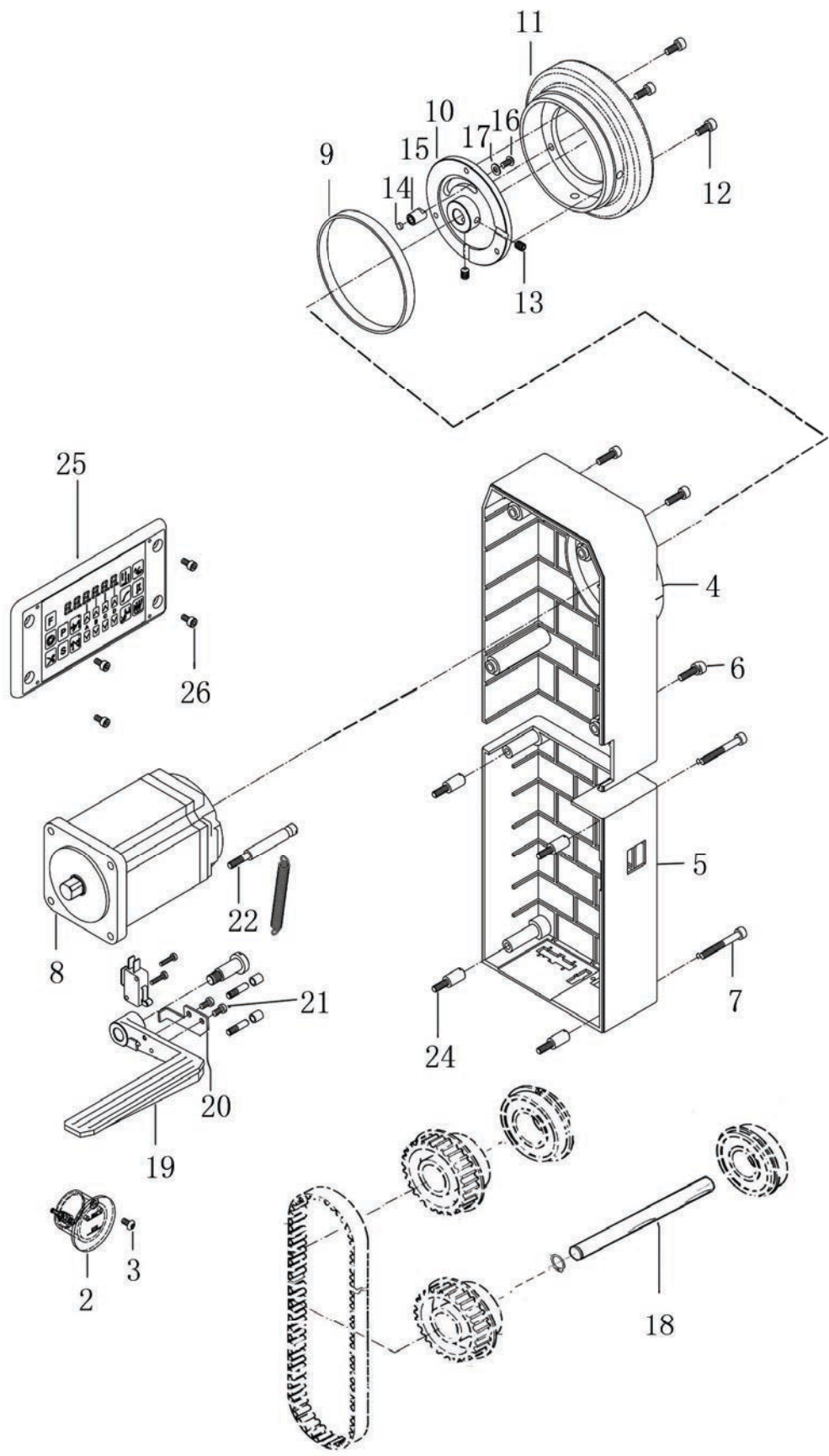





# Y. Accessories

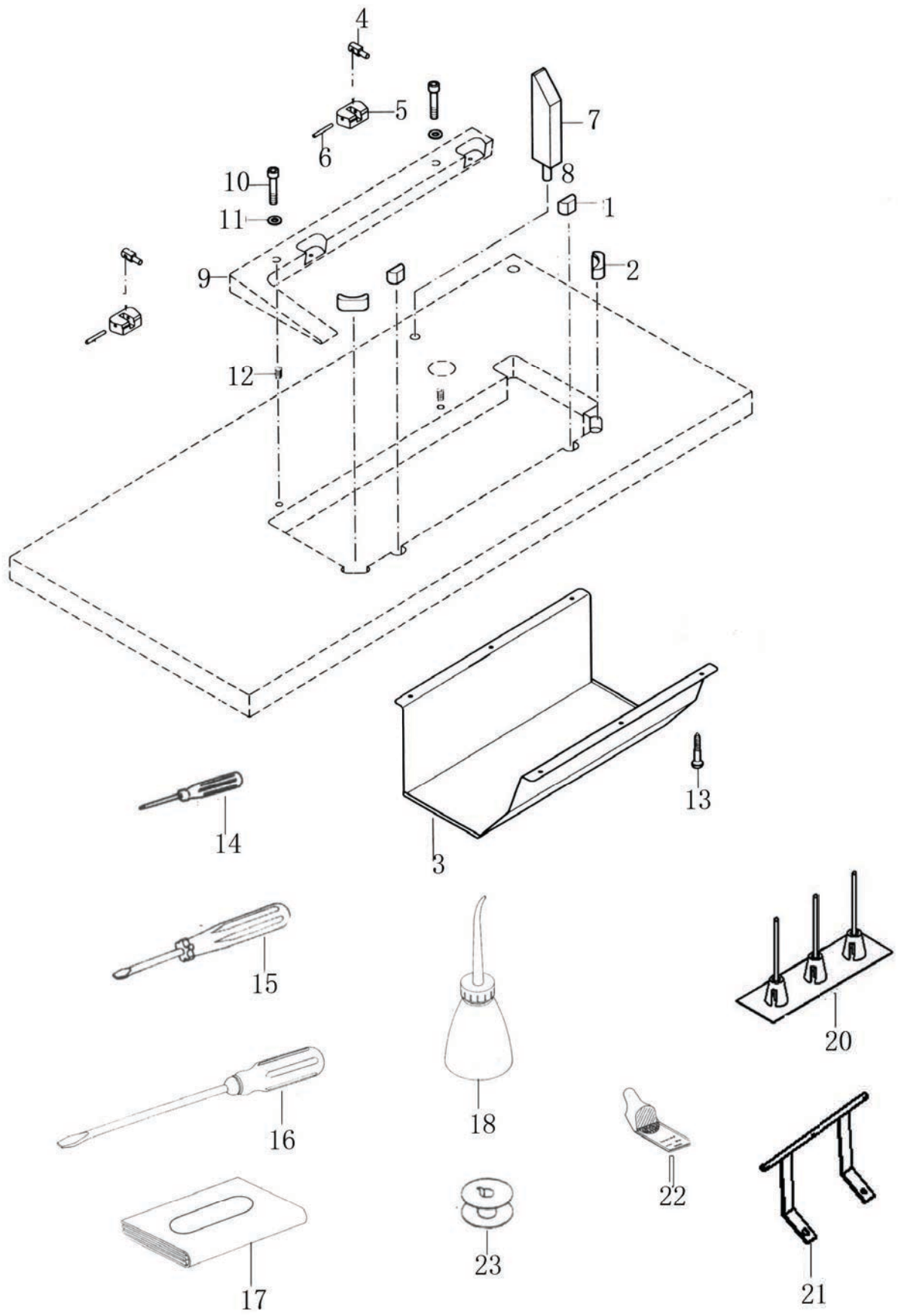



**OPERATION MANUAL**

**AC SERVO MOTOR**



**MODEL : 8900 SERIES**



# EC - Manufacturer Declaration

## EC Declaration of Conformity

We declare herewith that the following equipment :  
NEEDLE POSITIONER

AC SERVO MOTOR---i SERIES  
AC SERVO MOTOR---G SERIES  
AC SERVO MOTOR---GD SERIES  
AC SERVO MOTOR---MD SERIES  
Device---TK SERIES/TC SERIES/MK SERIES/MC SERIES

. is designed to be a driver of a sewing unit or system and must not be put into commission until the sewing unit or system has been declared in conformity with the provision of the EC Machinery Directives.

. complies with the following relevant provisions:  
-EC Low Voltage Directive (2006/95/EC)  
-EC Electromagnetic Compatibility Directive (2004/108/EC)  
-EC Machinery Directive (2006/42/EC)

Applied harmonized standards, especially :

EN 60204-31 Electrical equipment of industrial machines. Particular requirements for sewing machines, sewing units and sewing system.  
EN 292-1 Safety of machines.  
EN 292-2 Safety of machines, technical guidelines and specifications.  
EN 61000-6-2 EMS for industrial environment.  
EN 61000-6-3 EMI for residential environment.

## EG Konformitätserklärung

Hiermit erklären wir, dass die Bauart des Nähmaschinenantriebes :  
MOTOR TYP

AC SERVO MOTOR---i SERIES  
AC SERVO MOTOR---G SERIES  
AC SERVO MOTOR---GD SERIES  
AC SERVO MOTOR---MD SERIES  
Device---TK SERIES/TC SERIES/MK SERIES/MC SERIES.

zum Einbau in eine Näheinheit oder Nähanlage sind und dass Inbetriebnahme so lange untersagt ist, bis festgestellt wurde, dass die Näheinheit oder Nähanlage, in die dieser Nähmaschinenantrieb eingebaut werden soll, den Bestimmungen der EG-Maschinenrichtlinie entspricht.

. folgenden einschlägigen Bestimmungen entspricht :  
- EG Niederspannungsrichtlinie (2006/95/EWG)  
- EG EMV Richtlinie (2004/108/EWG)  
- EG Maschinenrichtlinie (2006/42/EWG)

Angewendete harmonisierte Normen, insbesondere :

EN 60204-31 Elektrische Ausrüstung von Industriemaschinen. Besondere Anforderungen für Nähmaschinen, Nähmaschinen und Nähanlagen.  
EN 292-1 Sicherheit von Maschinen, Grundsätzliche Terminologie und Methodik.  
EN 292-2 Sicherheit von Maschinen, Technische Leitsätze und Spezifikationen.  
EN 61000-6-2 EMS für Industrie Gebrauch.  
EN 61000-6-3 EMI für häuslich Gebrauch.

## Dichiarazione CE di conformità

Con la presente dichiariamo che la costruzione del motore per macchine per cucire :  
TIPO DI MOTORE

AC SERVO MOTOR---i SERIES  
AC SERVO MOTOR---G SERIES  
AC SERVO MOTOR---GD SERIES  
AC SERVO MOTOR---MD SERIES  
Device---TK SERIES/TC SERIES/MK SERIES/MC SERIES

. è destinata per essere incorporata in una unità di cucitura oppure in un impianto di cucitura. E vietata la sua messa in servizio prima che l'unità o l'impianto di cucitura in cui sarà incorporata sia stato dichiarato conforme alle disposizioni della direttiva CE per macchinari.

. è conforme alle seguenti disposizioni pertinenti :  
-Direttiva CE per bassa tensione (2006/95/CEE)  
-Direttiva CE per compatibilità elettromagnetica (2004/108/CEE)  
-Direttiva CE per macchinari (2006/42/CE)

Norme armonizzate utilizzate, in particolare :

EN 60204-31 Equipaggiamento elettrico di macchine industriali. Esigenze speciali per macchine per cucire, unità ed impianti di cucitura.  
EN 292-1 Sicurezza di macchinari, terminologia di base e metodica.  
EN 292-2 Sicurezza di macchinari, direttive tecniche e specifiche.  
EN 61000-6-2 EMS per l'ambiente industriale.  
EN 61000-6-3 EMI per l'ambiente residenziale.

## Déclaration CE de conformité

Par la présente, nous déclarons que le type de fabrication du moteur pour machines à coudre :  
TYPE DE MOTEUR

AC SERVO MOTOR---i SERIES  
AC SERVO MOTOR---G SERIES  
AC SERVO MOTOR---GD SERIES  
AC SERVO MOTOR---MD SERIES  
Device---TK SERIES/TC SERIES/MK SERIES/MC SERIES

. est destiné à être intégré à une unité ou un système de couture et que sa mise en service est interdite tant que l'unité ou le système de couture auquel il sera intégré n'ait été déclaré conforme aux dispositions de la directive CE sur les machines.

. répond aux suivantes dispositions pertinentes :  
- Directive CE sur la basse tension (2006/95/CEE)  
- Directive CE sur la compatibilité électromagnétique (2004/108/CEE)  
- Directive CE sur les machines (2006/42/CE)

Normes appliquées après harmonisation, en particulier :

EN 60204-31 Équipement électrique des machines industrielles. Règles particulières pour machines à coudre, unités et systèmes couture.  
EN 292-1 Sécurité des machines, terminologie de base, méthodologie.  
EN 292-2 Sécurité des machines, principes et spécifications techniques.  
EN 61000-6-2 EMS pour utilisation industrielle.  
EN 61000-6-3 EMI pour utilisation résidentiel.

## Declaração CE de Conformidade

Declaramos, pelo presente instrumento, que a construção do motor da máquina de costura :  
TIPO DO MOTOR

AC SERVO MOTOR---i SERIES  
AC SERVO MOTOR---G SERIES  
AC SERVO MOTOR---GD SERIES  
AC SERVO MOTOR---MD SERIES  
Device---TK SERIES/TC SERIES/MK SERIES/MC SERIES

. está destinada a ser incorporada numa unidade ou instalação de costura. Nunca colocar em serviço antes de a unidade de costura ou a instalação de costura em que este motor vai ser incorporado ser declarada em conformidade com o disposto na diretiva da CE sobre máquinas.

. corresponde às seguintes normas pertinentes :  
-Diretiva CE sobre baixa tensão (2006/95/CEE)  
-Diretiva CE sobre compatibilidade eletromagnética (2004/108/CEE)  
-Diretiva da CE sobre máquinas (2006/42/CE)

Normas harmonizadas aplicadas, em particular :

EN 60204-31 Equipamento eléctrico de máquinas industriais. Requisitos especiais para máquinas de costura, Unidades de costura e instalações de costura.  
EN 292-1 Segurança das máquinas, terminologia básica, metodologia.  
EN 292-2 Segurança das máquinas, normas básicas técnicas e especificações.  
EN 61000-6-2 EMS para ambiente industriais.  
EN 61000-6-3 EMI para ambiente residencial.

## EC Declaración de Conformidad

Declaramos junto con esto que el siguiente equipo :  
MOTOR SINCRONIZADOR

AC SERVO MOTOR---i SERIES  
AC SERVO MOTOR---G SERIES  
AC SERVO MOTOR---GD SERIES  
AC SERVO MOTOR---MD SERIES  
Device---TK SERIES/TC SERIES/MK SERIES/MC SERIES

. está diseñado para ser un controlador de una unidad de costura o sistema y no hay que ser puesto en servicio activo hasta que la unidad de costura o sistema se ha declarado conforme a la provisión de EC Directivas Maquinarias.

. Se conforma con las siguientes provisiones pertinentes :  
-EC Directiva Voltaje Bajo ( 2006/95/EEC )  
-EC Directiva Compatibilidad Electromagnética ( 2004/108/EEC )  
-EC Directiva Maquinaria ( 2006/42/EC )

Aplicado normas armonizadas, especialmente :

EN 60204-31 Equipo electrico de máquinas industrials. Requisito particular para máquinas de coser, Unidades de costura y sistema de costura.  
EN 292-1 Seguridad de máquinas.  
EN 292-2 Seguridad de máquinas, directrices técnicos y especificaciones.  
EN 61000-6-2 EMS para ambiente industrial.  
EN 61000-6-3 EMI para ambiente residencial.

H. S. Machinery. Co., Ltd

Mr. C. C. Lee Plant Manager

# Declaration of Conformity for Concentration Limits for Certain Hazardous Substances

We declare herewith that the following AC servo motor series products list below :

**AC Servo Motor --- i Series / G Series / GD Series / MD Series**

**Devrice---TK Series / TC Series / MK Series / MC Series**

Are complies with the following directives and requirements :

- 1. European Union RoHS Directive (2002/95/EC) and the concentration limits for certain hazardous substances (2005/618/EC)**
- 2. People's Republic of China Electronic Business Standard : Requirements for concentration limits for certain hazardous substances in electronic information products (SJ/T 11363-2006)**

Our product itself (motor, control box) or its packing materials and accessories (box, screws package, user manual, sticker, label, print...etc.) or the suppliers of parts and raw materials are all in conformity with the provision of the European Union RoHS Directive and People's Republic of China Electronic Business Standard to conform the following concentration limits for the six hazardous substances :

<b>Hazardous Substance</b>	<b>Permissible Values</b>
Lead (Pb)	240 ppm / Less than 240 ppm
Mercury (Hg)	800 ppm / Less than 800 ppm
Cadmium (Cd)	80 ppm / Less than 80 ppm
Hexavalent chromium (Cr VI)	800 ppm / Less than 800 ppm
Polybrominated Biphenyl (PBB)	800 ppm / Less than 800 ppm
Polybrominated Diphenyl ether (PBDE)	800 ppm / Less than 800 ppm

- \* The concentration of lead in the lead-free process for PCB shall be less than 800 ppm.
- \* For packing materials shipped with our products or parts, the hazardous substances shall be 80 ppm or less in sum of Pb+Hg+Cd+Cr VI.

H. S. Machinery. Co., Ltd



-----  
Mr. C. C. Lee      Plant Manager

# Content

I.	Safety instruction.....	1
II.	Wiring & earthing .....	4
III.	Function description for standby .....	5
IV.	Multi-function description .....	8
V.	Parameter selection description.....	9
VI.	Parameter value description.....	10
VII.	Parameter table.....	11
VIII.	.....	14
IX.	Point code & Error code.....	15

# I. Safety instruction

**User are asked to read this operation manual completely and carefully before installation or operation**

When install and operate TF control box, precaution must be taken as the following.  
This product is designed for specify sewing machines and must not be used for other purposes.

## 1.1 Work Environment

(1). Power voltage

Only use Power Voltage indicated on the name plate of the Feeder in  $\pm 10\%$  ranges.

(2). Electromagnetic pulse interference

To avoid the false operate, please keep the product away from the high electromagnetic machinery or electro pulse generator.

(3). Temperature:

a. Please don't operate in room temperature is above  $45^{\circ}\text{C}$  or under  $5^{\circ}\text{C}$

b. Avoid operating in direct sun light or outdoors area.

c. Avoid operating near the heater.

d. Avoid operating in the area which humidity is  $30\%$  or less and  $95\%$  or more, also keep away dew area.

(4). Atmosphere:

a. Avoid operating in dusty area, and stay away from corrosive material.

b. Avoid operating in evaporate or combustible gas area.

## 1.2 Safety In Installation :

(1). Control box: Follow the instruction in this manual for correct installation.

(2). Accessories: Turn off the power and unplug the cord before mounting any accessories.

- (3). Power cord:
- Avoid power cord being applied by heavy objects or excessive force, or over bend.
  - Power cord must not set to be near the V-belt and the pulley, keep 3 cm space or above.
  - Check the outlet voltage before plugging the cord, make sure it match the voltage shown on the name plate of the Feeder in  $\pm 10\%$  ranges.



**Attention : If the control box is AC 220V system, please don't connect to the AC 380V power outlet. If that happened, please turn off the power switch immediately and check the power voltage. Continue supply the 380V power over 5 minutes might damage the fuses (F1,F2) and burst the electrolytic capacitors (C3,C4) of the main board and even might endanger the person safety.**

(4). Grounding:

- To avoid the static interference and current leakage, all grounding must be done.
- Use the correct connector and extension wire when connecting ground wire to Earth and secure it tightly.

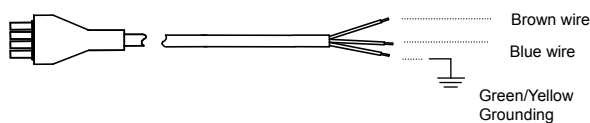

Ground Wire (Green/Yellow) must be grounding. Properly current leakage cause uncomfortable Even hurt the body if not grounding.

### 1.3 Safety In Operating :

- When turn on the machine in the first time, use low speed to operate and check the correct rotation direction.
- During machine operation, don't touch any moving parts.
- All moving parts must use the protective device to avoid the body contact and objects insertion.

#### **1.4 Safety in Maintenance and Repairs :**

Power must be turned off first, when :

- (1).Uninstall the motor or the control box, or plug and unplug any connector.
- (2).Turn off the power and wait 10 minutes before opening box cover.
- (3).Repairing or doing any mechanical adjustment.
- (4). Machines rest.

#### **1.5 Regulation in Maintenance and Repairs :**

- (1). Maintenance and Repairs must be done by specially trained personnel.
- (2). Don't use any objects or force to hit or ram the product.
- (3). All spare parts for repair must be approved or supplied by the manufacturer.

#### **1.6 Danger and Caution Signs :**



Risks that may cause personal injury or risk to the machine are marked with this symbol in the instruction manual.



This symbol indicates electrical risks and warnings.

#### **1.7 Warranty Information:**

Manufacturer provide a warranty in respect of the products covered for a period of 1 year use or 1 year and 6 months after the shipping date of the products for any defects arising in the normal course of use of the products by customers.



## II. Power Connection and Grounding

### (1). Single phase and three phase connection :

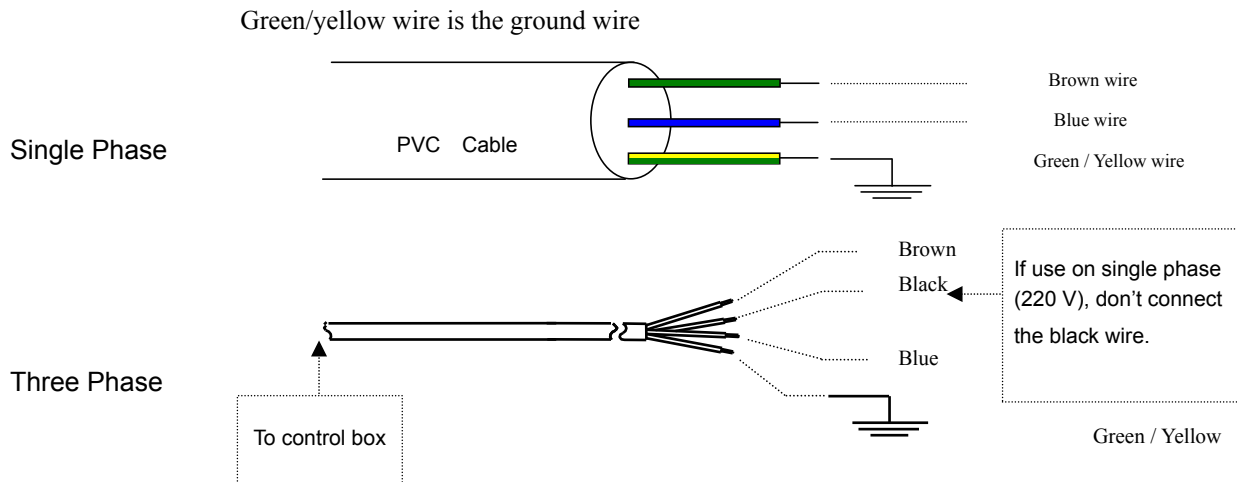

1. When a control box used on single phase 200 ~ 240 V power, only connect brown and blue wires. Use insulating tape to wrap up the black wire, in order to prevent the current leakage.
2. Green / Yellow wire must do the grounding.

### (2). How to connect a 1 $\Phi$ / 220 V power from a 3 $\Phi$ / 380 V power source



**Caution :** If the power source does not have the neutral point, then this control box is not suitable for this connection.

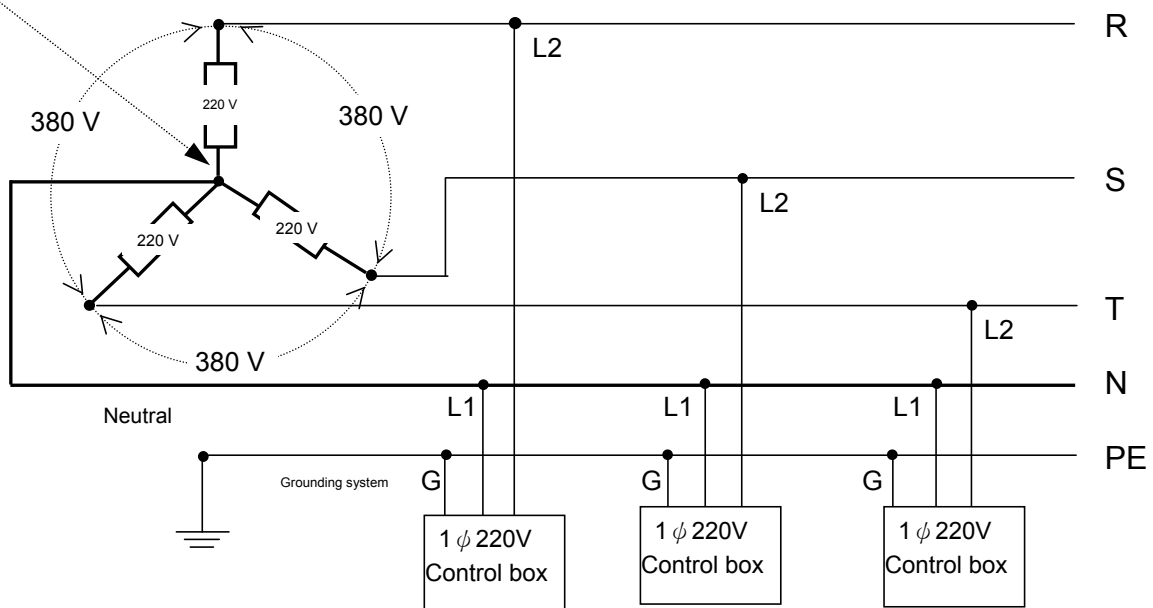

Caution: Must have a Neutral point





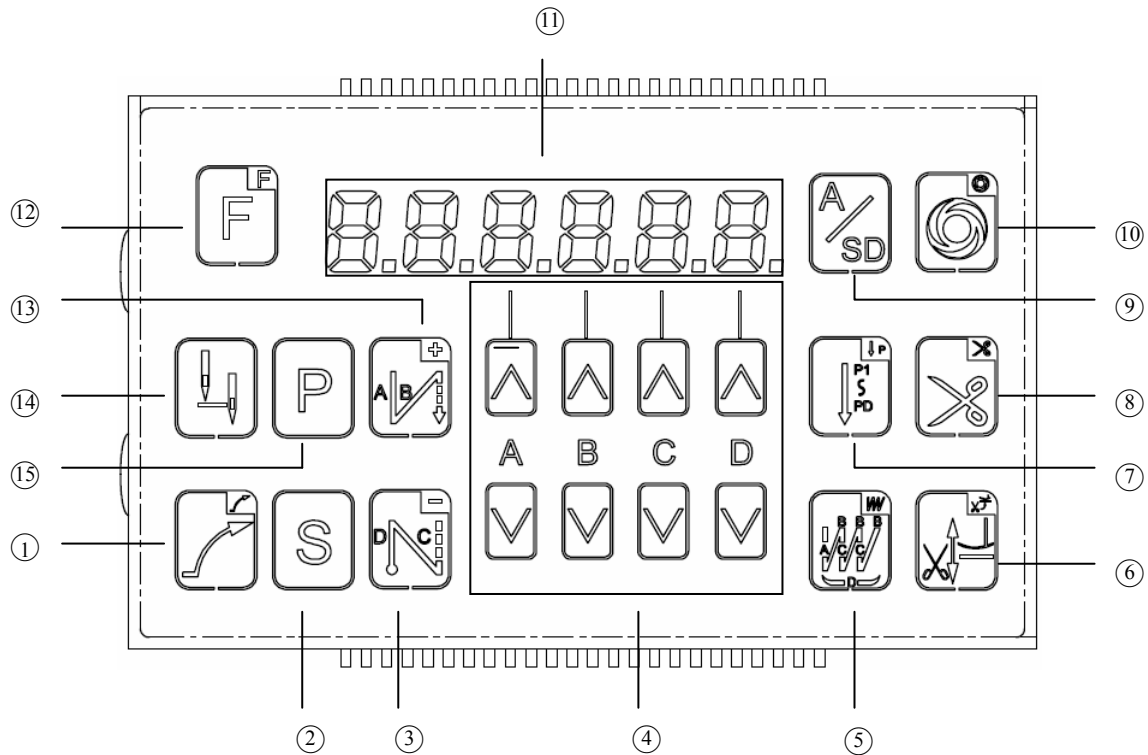





(3). Please consider R.S.T balance when connecting to several sewing machine.

### III. Function description at standby

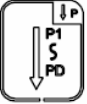

- ①  **Slow start**  
Motor run at slow speed when sewn start.
  
- ②  **Parameter setting**  
Press key and hold 2 second to enter parameter setting mode, set value you need after entered.
  
- ③  **End tacking**  
Press key, led light up, end tacking be performed, adjust C D to get stitch, maximum 15 stitches.

- ④  Value adjustment  
 = Increment /       = Decreasing
- ⑤  Bar tacking  
 Press key, led light up, bar tacking be performed, ABC maximum 15 stitches, D maximum 15 times .
- ⑥  Presser foot lifting automatically selection after trimmed.  
 Press key to perform this function.
- ⑦  Constant stitch  
 Press key to perform function, maximum 13 steps. Maximum 250 stitches each step.
- ⑧  Trimming  
 Press key to perform this function.
- ⑨  A/SD Function  
 Press key to perform this function.
- ⑩  Perform automatically  
 Press key to perform constant stitch function automatically.
- ⑪  Monitor  
 Press key to display value of A 、 B 、 C 、 D.

⑫ Multi function

You can choose, thread clamp, wiper, needle up/down, slow start, needle raising, counter through this key.



Start tacking

Press key to perform function, , adjust stitch of AB step, maximum 15 stitches each step.















Needle up/down selection

Needle up/down selection when motor stopped.



P Key

Press key and hold 2 seconds to change to parameter adjustment mode, set A ~ F group for fast parameter setting.

Mode	How to operation	Monitor	Range
Mode A	Press P &  together and hold  2 seconds.	001. H	001 ~ 046
Mode B	Press P &  together and hold  2 seconds.	047.MAC	001 ~ 122
Mode C	Press P &  together and hold  2 seconds.	123.FAS	001 ~ 251
Mode D	Press P &  together and hold  2 seconds.	176.UDN	001 ~ 251
Mode E	Press P &  together and hold  2 seconds.	208.UER	001 ~ 251
Mode F	Press P &  together and hold  2 seconds	252.CTP	252 ~ 254

## IV. Multi-function

 Press S at standby 2 seconds to change to multi-function.

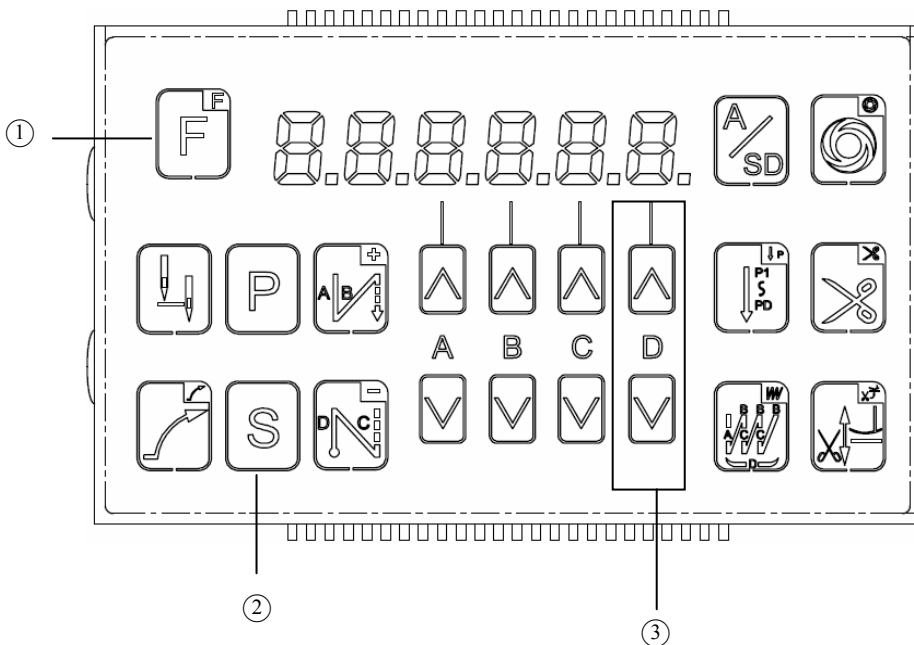

①  F Multi-function  
Press to perform/close function.

②  Return to standby

③ F Selection key for multi-function  
Select F0 ~ F6 function.

NO.	NAME	Definition
F0	NOP	No function
F1	FK	Thread clamp
F2	WON	Wiper
F3	NUD	Needle up/Down
F4	SLOW	Slow start
F5	USW	Needle raising
F6	CRS	Counter

# V. Parameter selection



Press P 2 seconds to change to parameter selection.

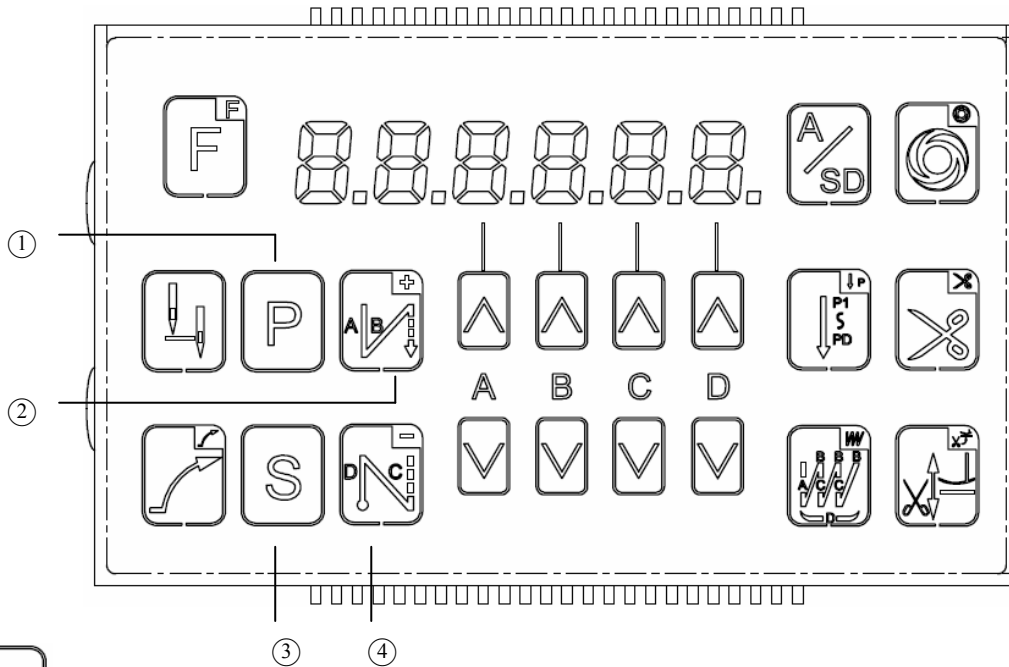

①



P Key

Increment of parameter.

②



Start tacking

Decreasing of parameter.

③



S Key

Enter parameter value mode.

④



End tacking

Parameter decreasing.

## VI. Parameter value setting



Press S at parameter selection mode to change to parameter value setting mode.

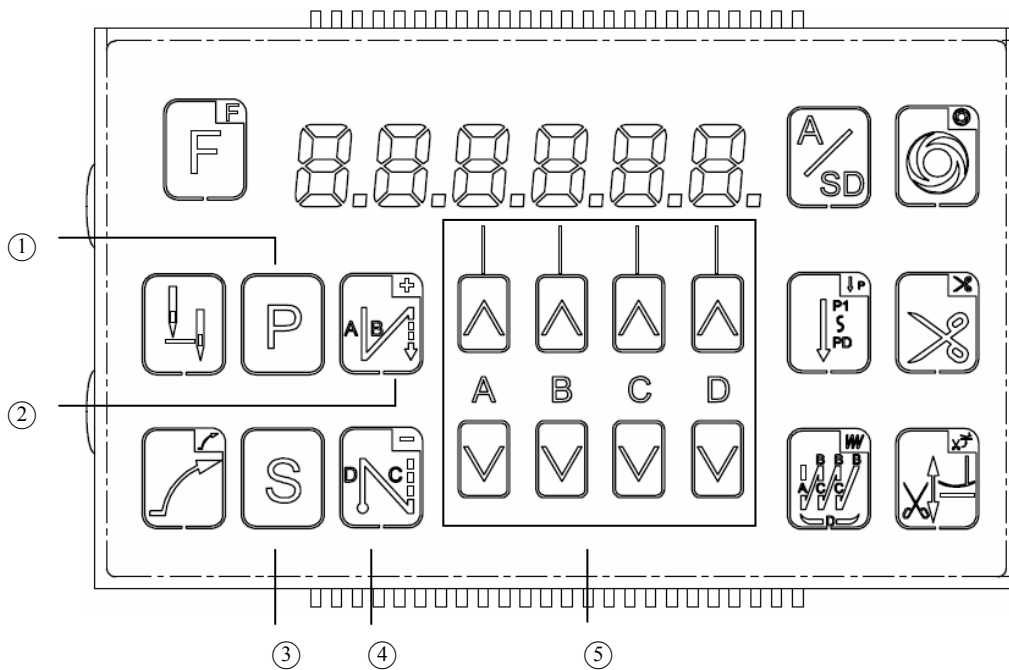

①



P Key

Return to parameter selection mode, parameter increment.

②



Start tacking

Return to parameter selection mode, parameter increment.

③



S Key

Return to standby.

④



End tacking

Return to parameter selection mode, parameter decreasing.

⑤   Value adjustment

 = Increment       = Decreasing

You must press S key to save adjusted value

## VII. Parameter table

Code	Function	Range	Description
001. H	( spm ) Maximum sewing speed	50~9999	Maximum speed adjustment
004. N	( spm ) Start tacking speed ( spm ) Constant stitch speed for interlock	50~ 8000	Start tacking speed Constant stitch speed for interlock adjustment
005. V	( spm ) End tacking speed	50~ 8000	Start tacking speed Constant stitch speed for interlock adjustment
006. B	( spm ) Bar tacking speed	50~ 8000	Bar tacking speed adjustment
007. S	( spm ) Slow start speed	50~ 2000	Slow start speed adjustment
008. SLS	Slow start stitch	0~99	Slow start stitch adjustment
009. A	( spm ) Auto constant stitch speed or Auto bar tacking speed	50~ 8000	Auto constant stitch speed Perform at 007 SMP=A



010. ACD	Perform end tacking automatically when constant stitch performed  Correction cancel setting too)	ON / OFF	ON : Perform end tacking when constant stitch be performed at last step  Correction can not be perform  OFF : Cannot perform end tacking when constant stitch be performed at last step  Correction can be perform at continuous stitch but must 011 RVM=B
011.RVM	Manual tacking function selection	J / B	J : JUKI Perform at sewing or sewing stop  B : BROTHER Perform at sewing
040.WON	Wiper(blow)	ON / OFF	ON Perform  OFF : Can not be perform
041. T M	Trimming	ON / OFF	ON : Perform OFF : Can not perform
045. S P	Sewing speed	0~8000	Sewing speed value
046. DIR	Rotation of motor	CW/ CCW	CW : Clockwise CCW : Counter clockwise
060. L	( spm ) Low speed	50~ 500	Low speed adjustment

B	061. T	( spm )Trimming speed	50~500	Trimming speed adjustment
	064. FO	( ms )	0~990	Presser foot lifting full on time setting
	065. FC	Duty circle for presser foot lifting	10~90	Presser foot lifter output duty circle to avoid getting heat
	066. FD	Motor start delay time to protect presser foot release	0~990	Pedal toe down motor delay to start , presser foot release
	070. HHC	Half heel to cancel presser foot lifting	ON / OFF	ON : Half heeling, presser foot no function OFF : Half heeling presser foot perform
	075. SFM	Safety switch	NC/NO	NO : Safety switch input normal open NC : Safety switch input normal close
	083. T 2	Trimming time (ms)	0~990	Trimming time
	087. L 2	Thread release (ms)	0~1500	
	093. W 2	Wiper (blow) (ms)	0~9990	
	119. DD	Motor drive type	ON / OFF	ON : Direct drive OFF : Belt drive
	121. ANU	Power on, presser foot at top position automatically	ON / OFF	ON : Power on, presser foot at top position automatically. OFF : No function
	122. HL	Maximum speed limitation	50~9999	Maximum speed limitation

## **VIII. Operation precaution**











1. please check JP1 must at 0V before power ON.
2. Pleases reboot if touches panel, PIN electronic components or circuit when power ON.
3. Do not touch panel, PIN electronic components or circuit.
4. Do not press to hard or used sharp article when operates panel.
5. Only uses finger to operate touch panel.
6. Do not operate touch panel by wet hand.
7. Do not operate touch panel by gloves.
8. Pleases keep clean on touch panel to get good sensitive of panel, dust or splotch will cause damage of panel.

## IX. Point code & error code

Error code	Cause	Description
ER0. 7	<ol style="list-style-type: none"> <li>1. Motor connector connect un-properly.</li> <li>2. Synchronizer out of order.</li> <li>3. Sewing machine locked or belt stuck by article.</li> <li>4. Material too thick.</li> </ol>	<p>Power shut down.</p> <p>Plases check motor or connector is normal or abnormal.</p> <p>Plases check the synchronizer.</p> <p>Plases check sewing machine stuck or hard to turn.</p>
ER0. 12	No synchronizer when power ON.	<p>Enter no synchronizer mode automatically.</p> <p>Plases check synchronizer plug in properly or not.</p>
ER0.16	<ol style="list-style-type: none"> <li>1. Safety switch out of order or connecting failed.</li> <li>2. Parameter value of 075 SFM is different to sewing machine.</li> </ol>	<p>Motor stop running.</p> <p>Plases check safety switch.</p> <p>Plases check parameter value of 075 SFM correct or not.</p>

## 7-Segment Display Characters Compare Table

### (Arabic Numerals)

Actual	0	1	2	3	4	5	6	7	8	9
Display										

### (English Alphabet)

(Actual)	A	B	C	D	E	F	G	H	I	J
(Display)										
(Actual)	K	L	M	N	O	P	Q	R	S	T
(Display)										
(Actual)	U	V	W	X	Y	Z				
(Display)										

Violators will be prosecuted