



使用說明書  
OPERATION MANUAL

AC 伺 服 馬 達  
AC SERVO MOTOR



MODEL :  $\epsilon$  70M SERIES

MINI-MOTOR TYPE



中 文 版

ENGLISH

賀欣全球售服網 / H. S. ELETRIC (SHANGHAI) CO., LTD  
服務專線 / SERVICE HOTLINE : +886-2-2676-5203  
傳真 / FAX : +886-2-2689-6600, 2689-3657  
電子郵件 / E-MAIL : service@hohsing.com.tw  
網址 / WEBSITE : http://www.hohsing.com

中國地區 (CHINA)  
服務專線 : +86-21-64908325  
傳真 : +86-21-54570064  
網址 : http://www.hohsing.com

HSVP7MU01 - 1  
2011.01

# EC - Manufacturer Declaration

## EC Declaration of Conformity

We declare herewith that the following equipment :  
NEEDLE POSITIONER

AC SERVO MOTOR---HVP-70 SERIES  
AC SERVO MOTOR---HVP-90 SERIES  
AC SERVO MOTOR---HVP-20 SERIES  
AC SERVO MOTOR---i SERIES

. is designed to be a driver of a sewing unit or system and must not be put into commission until the sewing unit or system has been declared in conformity with the provision of the EC Machinery Directives.

. complies with the following relevant provisions:

- EC Low Voltage Directive (2006/95/EC)
- EC Electromagnetic Compatibility Directive (2004/108/EC)
- EC Machinery Directive (2006/42/EC)

Applied harmonized standards, especially :

EN 60204-31	Electrical equipment of industrial machines. Particular requirements for sewing machines, sewing units and sewing system.
EN 292-1	Safety of machines.
EN 292-2	Safety of machines, technical guidelines and specifications.
EN 61000-6-2	EMS for industrial environment.
EN 61000-6-3	EMI for residential environment.

## EG Konformitätserklärung

Hiermit erklären wir, dass die Bauart des Nähmaschinenantriebes :  
MOTOR TYP

AC SERVO MOTOR---HVP-70 SERIEN  
AC SERVO MOTOR---HVP-90 SERIEN  
AC SERVO MOTOR---HVP-20 SERIEN  
AC SERVO MOTOR---i SERIEN

. zum Einbau in eine Näheinheit oder Nähanlage sind und dass Inbetriebnahme so lange untersagt ist, bis festgestellt wurde, dass die Näheinheit oder Nähanlage, in die dieser Nähmaschinenantrieb eingebaut werden soll, den Bestimmungen der EG-Maschinenrichtlinie entspricht.

. folgenden einschlägigen Bestimmungen entspricht :

- EG Niederspannungsrichtlinie (2006/95/EWG)
- EG EMV Richtlinie (2004/108/EWG)
- EG Maschinenrichtlinie (2006/42/EWG)

Angewendete harmonisierte Normen, insbesondere :

EN 60204-31	Elektrische Ausrüstung von Industriemaschinen. Besondere Anforderungen für Nähmaschinen, Nähmaschinen und Nähanlagen.
EN 292-1	Sicherheit von Maschinen, Grundsätzliche Terminologie und Methodik.
EN 292-2	Sicherheit von Maschinen, Technische Leitsätze und Spezifikationen.
EN 61000-6-2	EMS für Industrie Gebrauch.
EN 61000-6-3	EMI für häuslich Gebrauch.

## Dichiarazione CE di conformità

Con la presente dichiaro che la costruzione del motore per macchine per cucire :  
TIPO DI MOTORE

AC SERVO MOTORE---HVP-70 SERIE  
AC SERVO MOTORE---HVP-90 SERIE  
AC SERVO MOTORE---HVP-20 SERIE  
AC SERVO MOTORE---i SERIE

. è destinata per essere incorporata in una unità di cucitura oppure in un impianto di cucitura. E vietata la sua messa in servizio prima che l'unità o l'impianto di cucitura in cui sarà incorporata sia stato dichiarato conforme alle disposizioni della direttiva CE per macchinari.

. è conforme alle seguenti disposizioni pertinenti :

- Direttiva CE per bassa tensione (2006/95/CEE)
- Direttiva CE per compatibilità elettromagnetica (2004/108/CEE)
- Direttiva CE per macchinari (2006/42/CE)

Norme armonizzate utilizzate, in particolare :

EN 60204-31	Equipaggiamento elettrico di macchine industriali. Esigenze speciali per macchine per cucire, unità ed impianti di cucitura.
EN 292-1	Sicurezza di macchinari, terminologia di base e metodica.
EN 292-2	Sicurezza di macchinari, direttive tecniche e specifiche.
EN 61000-6-2	EMS per l'ambiente industriale.
EN 61000-6-3	EMI per l'ambiente residenziale.

## Déclaration CE de conformité

Par la présente, nous déclarons que le type de fabrication du moteur pour machines à coudre :  
TYPE DE MOTEUR

AC SERVO MOTEUR---HVP-70  
AC SERVO MOTEUR---HVP-90  
AC SERVO MOTEUR---HVP-20  
AC SERVO MOTEUR---i

. est destiné à être intégré à une unité ou un système de couture et que sa mise en service est interdite tant que l'unité ou le système de couture auquel il sera intégré n'ait été déclaré conforme aux dispositions de la directive CE sur les machines.

. répond aux suivantes dispositions pertinentes :

- Directive CE sur la basse tension (2006/95/CEE)
- Directive CE sur la compatibilité électromagnétique (2004/108/CEE)
- Directive CE sur les machines (2006/42/CE)

Normes appliquées après harmonisation, en particulier :

EN 60204-31	Équipement électrique des machines industrielles. Règles particulières pour machines à coudre, unités et systèmes couture.
EN 292-1	Sécurité des machines, terminologie de base, méthodologie.
EN 292-2	Sécurité des machines, principes et spécifications techniques.
EN 61000-6-2	EMS pour utilisation industrielle.
EN 61000-6-3	EMI pour utilisation résidentiel.

## Declaração CE de Conformidade

Declaramos, pelo presente instrumento, que a construção do motor da máquina de costura :  
TIPO DO MOTOR

AC SERVO MOTOR---HVP-70 SÉRIE  
AC SERVO MOTOR---HVP-90 SÉRIE  
AC SERVO MOTOR---HVP-20 SÉRIE  
AC SERVO MOTOR---i SÉRIE

. está destinada a ser incorporada numa unidade ou instalação de costura. Nunca colocar em serviço antes de a unidade de costura ou a instalação de costura em que este motor vai ser incorporado ser declarada em conformidade com o disposto na directiva da CE sobre máquinas.

. corresponde às seguintes normas pertinentes :

- Directiva CE sobre baixa tensão (2006/95/CEE)
- Directiva CE sobre compatibilidade electromagnética (2004/108/CEE)
- Directiva da CE sobre máquinas (2006/42/CE)

Normas harmonizadas aplicadas, em particular :

EN 60204-31	Equipamento eléctrico de máquinas industriais. Requisitos especiais para máquinas de costura, Unidades de costura e instalações de costura.
EN 292-1	Segurança das máquinas, terminologia básica, metodologia.
EN 292-2	Segurança das máquinas, normas básicas técnicas e especificações.
EN 61000-6-2	EMS para ambiente industriais.
EN 61000-6-3	EMI para ambiente residencial.

## EC Declaración de Conformidad

Declaramos junto con esto que el siguiente equipo :  
MOTOR SINCRONIZADOR

AC MOTOR SERVO---HVP-70 SERIE  
AC MOTOR SERVO---HVP-90 SERIE  
AC MOTOR SERVO---HVP-20 SERIE  
AC MOTOR SERVO---i SERIE

. está diseñado para ser un controlador de una unidad de costura o sistema y no hay que ser puesto en servicio activo hasta que la unidad de costura o sistema se ha declarado conforme a la provisión de EC Directivas Maquinarias.

. Se conforma con las siguientes provisiones pertinentes :

- EC Directiva Voltaje Bajo ( 2006/95/EEC )
- EC Directiva Compatibilidad Electromagnética ( 2004/108/EEC )
- EC Directiva Maquinaria ( 2006/42/EC )

Aplicado normas armonizadas, especialmente :

EN 60204-31	Equipo eléctrico de máquinas industriales. Requisito particular para máquinas de coser, Unidades de costura y sistema de costura.
EN 292-1	Seguridad de máquinas.
EN 292-2	Seguridad de máquinas, directrices técnicas y especificaciones.
EN 61000-6-2	EMS para ambiente industrial.
EN 61000-6-3	EMI para ambiente residencial.

H. S. Machinery. Co., Ltd

Mr. C. C. Lee Plant Manager

# 有毒物質限量指令自我宣告書

## Declaration of Conformity for Concentration Limits for Certain Hazardous Substances

本公司所生產之伺服馬達產品系列如下所列：

We declare herewith that the following AC servo motor series products list below：

**AC 伺服馬達--- HVP-70 系列/ HVP-90 系列/ HVP-20 系列/ M 系列 / i 系列**

**AC Servo Motor --- HVP-70 Series / HVP-90 Series / HVP-20 Series / M Series/ i Series**

皆符合以下指令及要求：

Are complies with the following directives and requirements：

1. 歐盟 RoHS 指令 (2002/95/EC) 及有毒物質的限量要求 (2005/618/EC)
2. 中華人民共和國電子行業標準：電子信息產品中有毒有害物質的限量要求 (SJ/T 11363-2006)

1. European Union RoHS Directive (2002/95/EC) and the concentration limits for certain hazardous substances (2005/618/EC)
2. People's Republic of China Electronic Business Standard : Requirements for concentration limits for certain hazardous substances in electronic information products (SJ/T 11363-2006)

本公司產品本身(馬達,控制箱)或其包裝材料及附件(紙箱,螺絲配件包,說明書,貼紙,標籤,印刷品...等等)或其元件與原材料供應商皆依照歐盟 RoHS 指令及中華人民共和國電子行業標準的限量規定而符合以下所列之六種有毒物質的限量要求：

Our product itself (motor, control box) or its packing materials and accessories (box, screws package, user manual, sticker, label, print...etc.) or the suppliers of parts and raw materials are all in conformity with the provision of the European Union RoHS Directive and People's Republic of China Electronic Business Standard to conform the following concentration limits for the six hazardous substances：

有毒物質 / Hazardous Substance	限量要求 / Permissible Values
鉛 Lead (Pb)	低於 240 ppm / Less than 240 ppm
汞 Mercury (Hg)	低於 800 ppm / Less than 800 ppm
鎘 Cadmium (Cd)	低於 80 ppm / Less than 80 ppm
六價鉻 Hexavalent chromium (Cr VI)	低於 800 ppm / Less than 800 ppm
多溴聯苯 Polybrominated Biphenyl (PBB)	低於 800 ppm / Less than 800 ppm
多溴二苯醚 Polybrominated Diphenyl ether (PBDE)	低於 800 ppm / Less than 800 ppm

- \* 基板的無鉛製程：總鉛含有濃度基準量 800 ppm 以下。
- \* The concentration of lead in the lead-free process for PCB shall be less than 800 ppm.
- \* 包裝材料：Pb+Hg+Cd+Cr VI 含有濃度基準總共合計 80 ppm 以下。
- \* For packing materials shipped with our products or parts, the hazardous substances shall be 80 ppm or less in sum of Pb+Hg+Cd+Cr VI.

H. S. Machinery. Co., Ltd



-----  
Mr. C. C. Lee Plant Manager

## ❧ 70M EMI SHIELD CONNECTION WIRE OF MOTOR POWER CABLE INSTALLATION

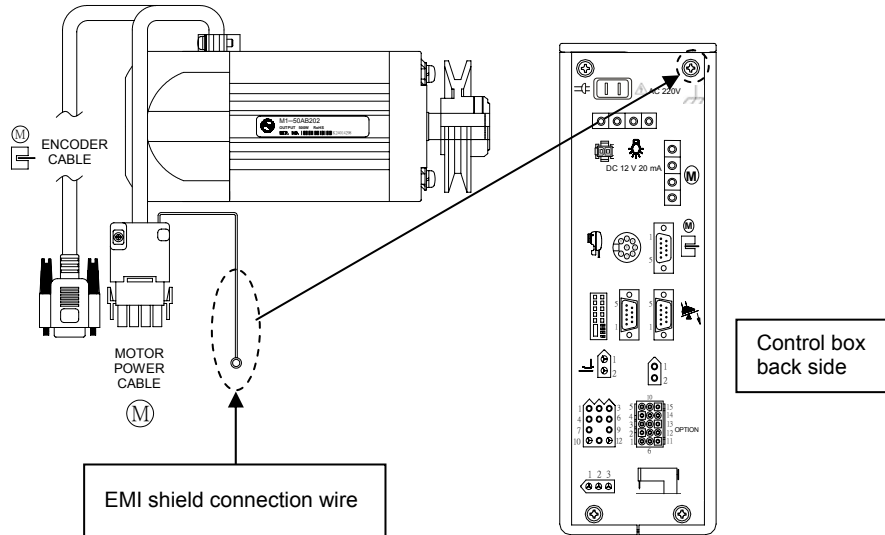

When connecting the motor power cable to the control box, also securing the EMI shield connection wire to the grounding screw hole in the back side of the control box. (see the diagram for securing location)

# Model : *ε* 70M Series Contents

---

---

	Page
<b>1. Safety Precaution</b>	
1.1 Work environment	1
1.2 Safety in installation	1
1.3 Safety in operating	2
1.4 Safety in maintenance and repairs	2
1.5 Regulation in maintenance and repairs	2
1.6 Danger and caution signs	2
1.7 Warranty information	2
<b>2. Installation and Adjustment</b>	
(1). Motor installation	3
(2). Control box installation	3
(3). Speed control unit installation	3
(4). Components of belt cover adjustment	4
(5). Install the belt cover	4
(6). Install and adjust the synchronizer	5
(7). Adjust the speed control unit	5
<b>3. Power Connection and Grounding</b>	
(1). Single phase and three phase connection	6
(2). How to connect a 1Φ / 220 V power from a 3 Φ / 380 V power source	6
(3). The usage of AC 220V Lamp Connector	6
(4). The load balance when use a 1Φ / 220 V motor used on a 3 Φ / 220 V power source	7
(5). How to change solenoid supply voltage (DC 24 V or 30 V)	7
<b>4. Diagrams of Control Box</b>	
(1). Front side of the control box	8
(2). Rear side of the control box	8
<b>5. Programmable 7-segment Display</b>	
(1). How to access the 【Normal Mode】	9
(2). Key functions in the 【Normal Mode】 for a lockstitch machine	9
(3). Key functions in the 【Normal Mode】 for a interlock machine	10
(4). How to perform 『BAR Tacking』 and 『Constant-Stitch Sewing』 in the 【Normal Mode】	10
(5). How to access 【Parameter Mode A】	11
(6). How to access 【Parameter Mode B】	11
(7). Key functions in the 【Parameter Mode A and B】	12
(8). How to adjust the parameter setting	12
(9). Setting values for A、 B、 C、 D keys	13

	<b>Page</b>
<b>6. General Parameter Table</b>	14
<b>7. Basic Troubleshooting</b>	
(1). Error code and measurement	15
(2). Instruction of fuse replacement	16
(3). 70M parts list	17
<b>9. Basic Diagrams of Connector Panel</b>	
(1). 70M-4-66 (V7)	18
(2). 70M -4-46 (T2)	19

**Appendix : 7-Segment Display Characters Compare Chart**

## 1. Safety Precaution :

**Please read this manual carefully , also with related manual for the machine head before use. For perfect operation and safety, installing and operating this product by trained personnel is required.**

When install and operate  $\epsilon$  70L Servo Motor, precaution must be taken as the following.  
This product is designed for specify sewing machines and must not be used for other purposes.

### 1.1 Work Environment :

(1). Power voltage:

Only use Power Voltage indicated on the name plate of the  $\epsilon$  70L in  $\pm 10\%$  ranges.

(2). Electromagnetic pulse interference:

To avoid the false operate, please keep the product away from the high electromagnetic machinery or electro pulse generator.



(3). Temperature:

a. Please don't operate in room temperature is above  $45^{\circ}\text{C}$  or under  $5^{\circ}\text{C}$

b. Avoid operating in direct sun light or outdoors area.

c. Avoid operating near the heater.

d. Avoid operating in the area which humidity is  $30\%$  or less and  $95\%$  or more, also keep away dew area.

(4). Atmosphere:

a. Avoid operating in dusty area, and stay away from corrosive material.

b. Avoid operating in evaporate or combustible gas area.

### 1.2 Safety In Installation :

(1). Motor and control box: Follow the instruction in this manual for correct installation.

(2). Accessories: Turn off the power and unplug the cord before mounting any accessories.

(3). Power cord:

a. Avoid power cord being applied by heavy objects or excessive force, or over bend.

b. Power cord must not set to be near the V-belt and the pulley, keep 3 cm space or above.

c. Check the outlet voltage before plugging the cord, make sure it match the voltage shown on the name plate of the  $\epsilon$  70L in  $\pm 10\%$  ranges.

**Attention : If the control box is AC 220V system, please don't connect to the AC 380V power outlet, otherwise the error code E r 0 . 4 will occur. If that happened, please turn off the power switch immediately and check the power voltage. Continue supply the 380V power over 5 minutes might damage the fuses (F1,F2) and burst the electrolytic capacitors (C3,C4) of the main board and even might endanger the person safety.**



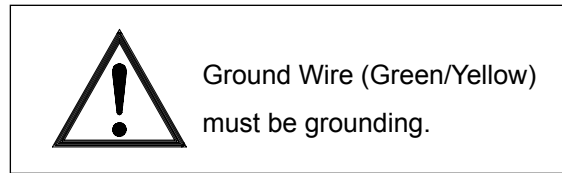
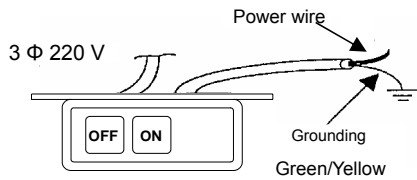

(4). Grounding:

- a. To avoid the static interference and current leakage, all grounding must be done.
- b. Use the correct connector and extension wire when connecting ground wire to Earth and secure it tightly.

**1.3 Safety In Operating :**

- (1). When turn on the machine in the first time, use low speed to operate and check the correct rotation direction.
- (2). During machine operation, don't touch any moving parts.
- (3). All moving parts must use the protective device to avoid the body contact and objects insertion.

**1.4 Safety in Maintenance and Repairs :**

Power must be turned off first, when:

- (1).Uninstall the motor or the control box, or plug and unplug any connector.
- (2).Turn off the power and wait 10 minutes before opening box cover.

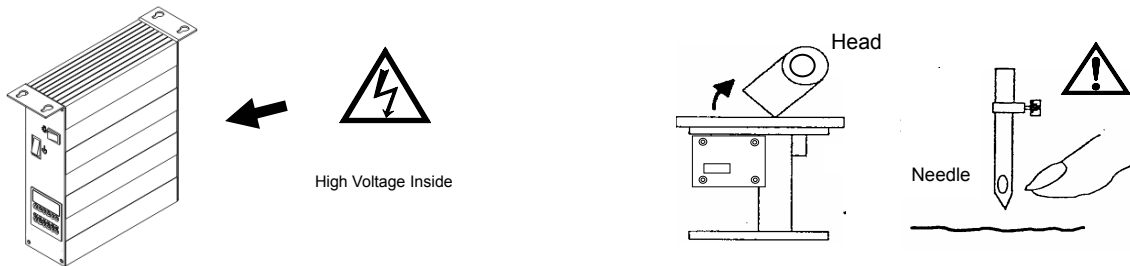

- (3).Raising the machine arms or changing needle, or threading needle.(show as above)
- (4).Repairing or doing any mechanical adjustment.
- (5).Machines rest.

**1.5 Regulation in Maintenance and Repairs :**

- (1).Maintenance and Repairs must be done by specially trained personnel.
- (2).Don't cover up motor's ventilation, it can cause motor over heated.
- (3).Don't use any objects or force to hit or ram the product.
- (4).All spare parts for repair must be approved or supplied by the manufacturer.

**1.6 Danger and Caution Signs :**



Risks that may cause personal injury or risk to the machine are marked with this symbol in the instruction manual.



This symbol indicates electrical risks and warnings.

**1.7 Warranty Information :**

Manufacturer provide a warranty in respect of the products covered for a period of 1 year use or 1 year and 6 months after the shipping date of the products for any defects arising in the normal course of use of the products by customers.





## 2. Installation and Adjustment:

### (1). Motor installation:

A). When motor and machine installed together, refer to the machine head's instruction.

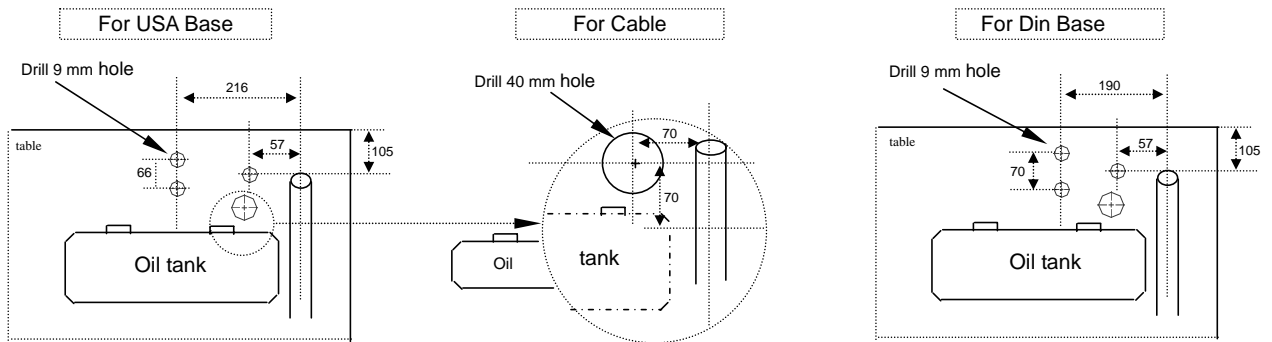
B). When motor installed under the working table, drill holes in the table as the following diagram for the installation.





- 1). Pulleys of motor and machine must properly align.
- 2). Cable pass through under the working table must be secured to avoid the V-belt to be rubbed.
- 3). Use the motor base arm to adjust belt's tensions.

### (2). Control Box Installation:

a). Leave 100 mm space at right

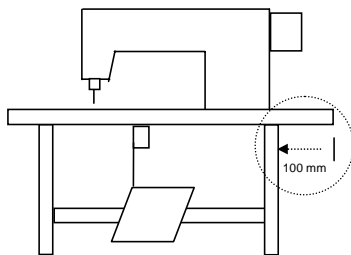

b). Mounting  $\sphericalangle$  70L under the working table

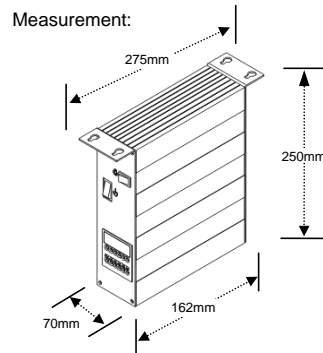

c). Installation layout

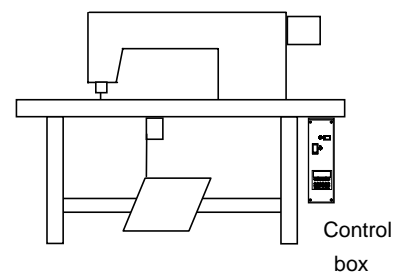

### (3). Speed Control Unit Installation:

a). Speed Control Unit

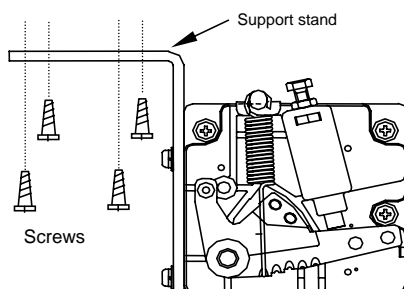

Always use screwdriver to tightly secure screws

b). Keep rod in vertical, secure the unit under the table

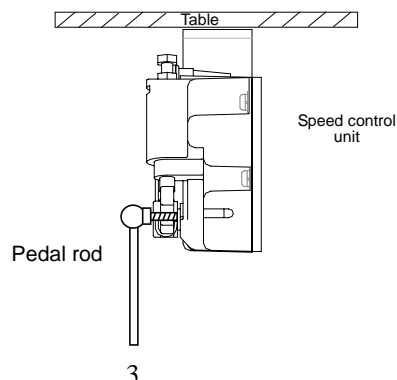

c). Installation layout

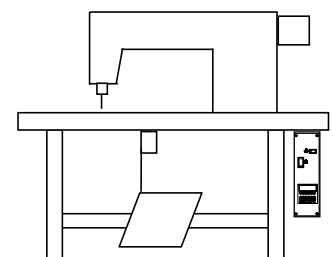

#### (4). Components of Belt Cover Adjustment:

##### A. Finger Guard Adjustment : ( For CE type only )

- 1). Factory default, Finger guard is set at ( B ). (for lockstitch machine rotation direction)
- 2). When use Interlock stitch machine, Finger guard is set at (C).

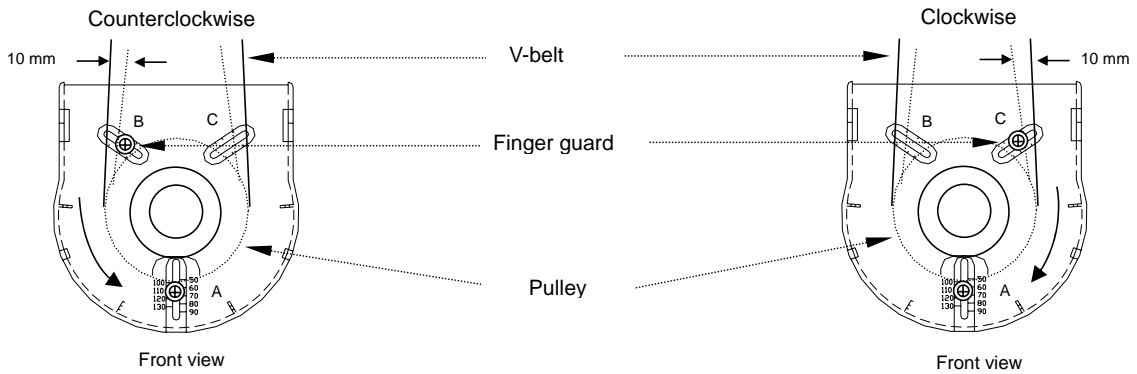

##### B. Belt Stopper Adjustment :

- a. Factory default Belt stopper is mount at pulley scale about 100 mm's position (Fig. A ), if pulley size change, follow the Fig. B.
- b. Adjustment tips: Move stopper pointer aligned with any position at pulley diameter scale that matches the pulley diameter size, if didn't know the pulley diameter size, please push the stopper until to touch the pulley then return back 5-10mm position.

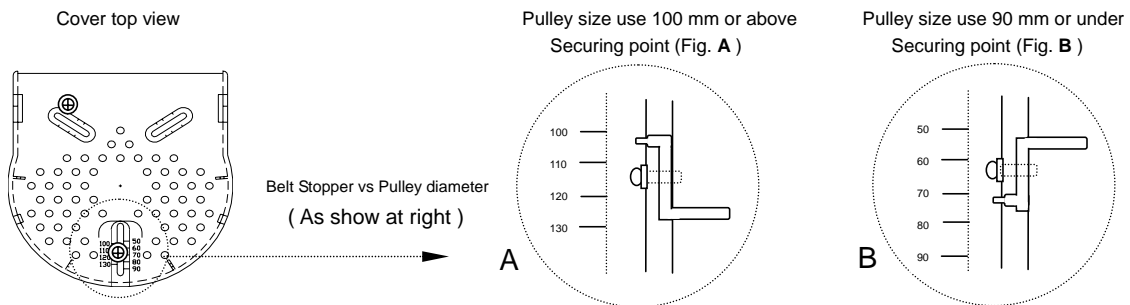

#### (5). Install the Belt Cover:

- a). Install the belt cover bracket at motor front cover.(screw hole face motor)

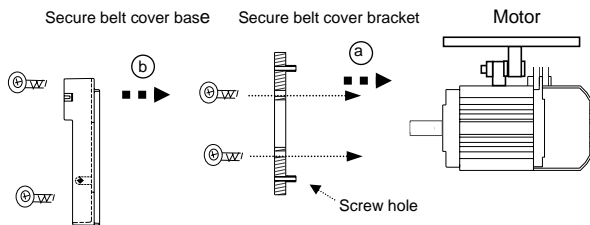

- b). Then secure base to the belt cover bracket, let the opening face machine pulley.

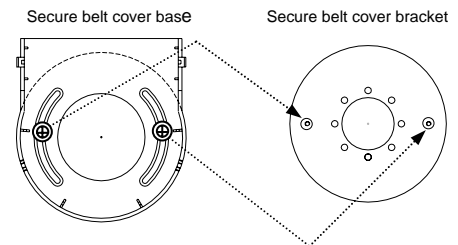

- c). After install base, mount with the motor pulley and secure it.

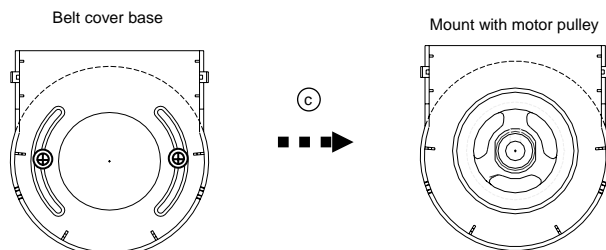

- d). Finally put the belt cover and secure screw A, B

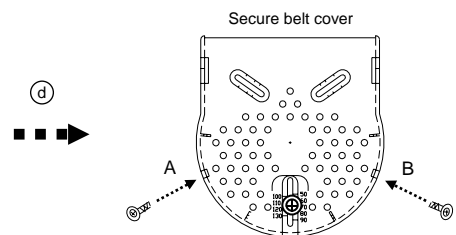

## (6). Install and Adjust the Synchronizer (sensor):

- a). Synchronizer installation : Mounting the Synchronizer onto the flange of machine pulley and fasten the rotor by setting screws.
- b). Synchronizer adjustment : Before adjustment, unscrew the synchronizer's cover screw, and remove the cover.



Caution :  
Turn OFF the power, before making the adjustment.

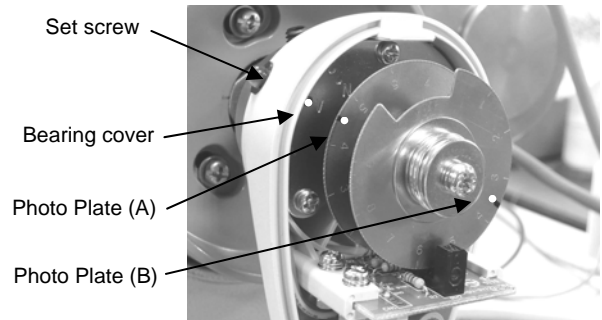

Needle up position : Rotate the machine pulley to reach mechanical needle up position and turn the photo plate (A) until its red mark is aligned with the red mark on the bearing cover plate.

Needle down position : Rotate the machine pulley to reach mechanical needle down position and turn the photo plate (B) until its blue mark is aligned with the red mark on the bearing cover plate.



Note: instruction above is the standard adjustment. If you feel the position wasn't accurate, please do the fine tuning by yourself.

## (7). Adjust the Speed Control Unit

Components of the speed control unit: see figure

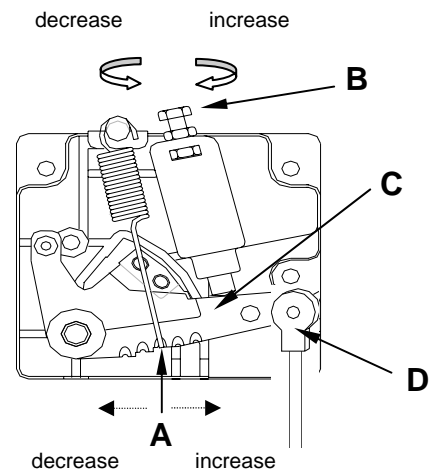
- A : Spring for toeing forward force adjustment
- B : Bolt for heeling backward force adjustment
- C : Treadle / Pedal arm.
- D : Pitman Rod for Treadle / Pedal





Term of adjustment		Adjustment result
1	Toeing forward force adjustment	Spring A move to right = force increased Spring A move to left = force decreased
2	Heeling backward force adjustment	Bolt B turn  = force decreased Bolt B turn  = force increased
3	Treadle stroke adjustment	Rod D secure at right = stroke is longer , Rod D secure at left = stroke is shorter.

### 3. Power Connection and Grounding:

#### (1). Single phase and three phase connection:

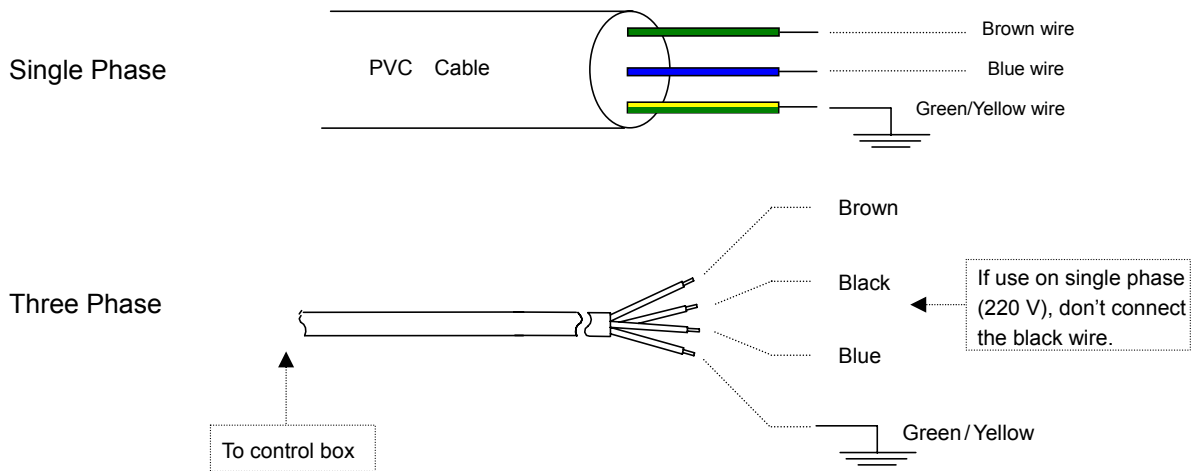
Green/yellow wire is the ground wire.





1. When a three phase 220 V servo motor used on single phase 200 ~ 240 V power, only connect brown and blue wires. Use insulating tape to wrap up the black wire, in order to prevent the current leakage.
2. Green / Yellow wire must do the grounding.

#### (2). How to connect a 1Φ / 220 V power from a 3 Φ / 380 V power source



**Caution :** If the power source does not have the neutral point, then this 1Φ / 220 V servo motor is not suitable for this connection. Please ask supplier to offer our 3Φ / 380 V servo motor.

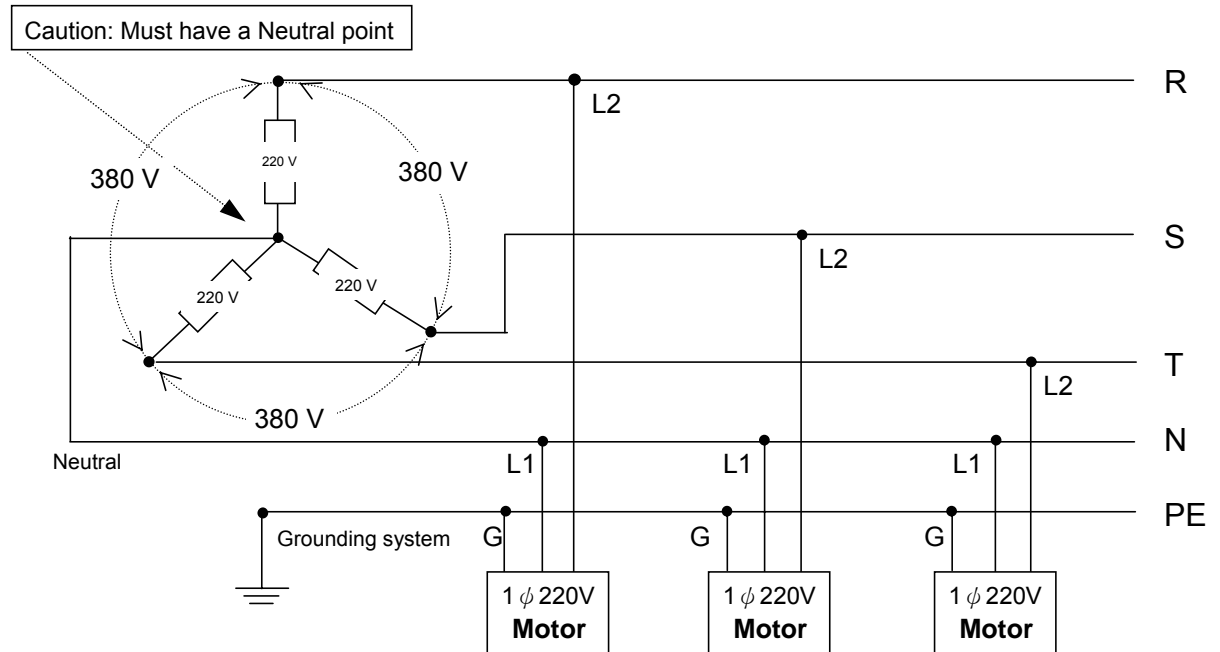

#### (3). The usage of AC 220V Lamp Connector

Industrial sewing machine use only, must not be used for any other purpose.

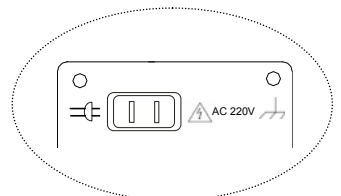

(4). The load balance when use a 1Φ / 220 V motor used on a 3 Φ / 220 V power source.

See the following figure for the load balance.

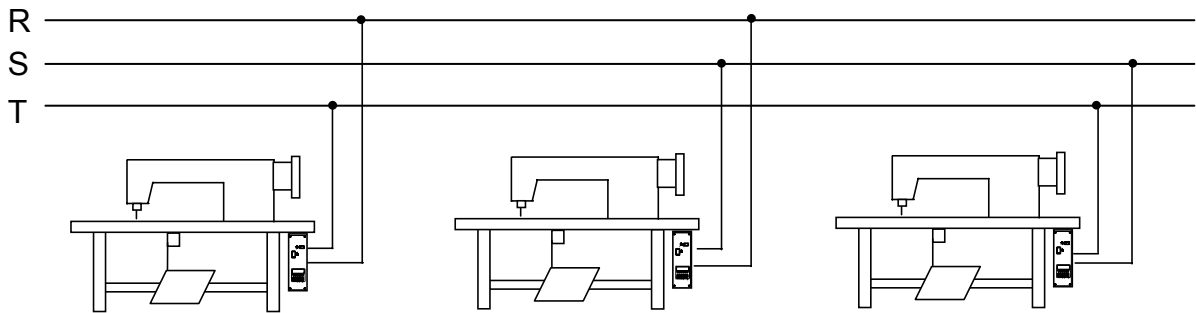



(5). How to change solenoid supply voltage (DC: 24 V OR 30 V) :

The JP1 is for 30 V and JP2 is for 24 V.

 **Caution:** Before making the switch, check the machine head's Solenoid specification.

 **Caution:** Turn off the power wait for 10 min. before open the cover, then make the change.





High Voltage inside

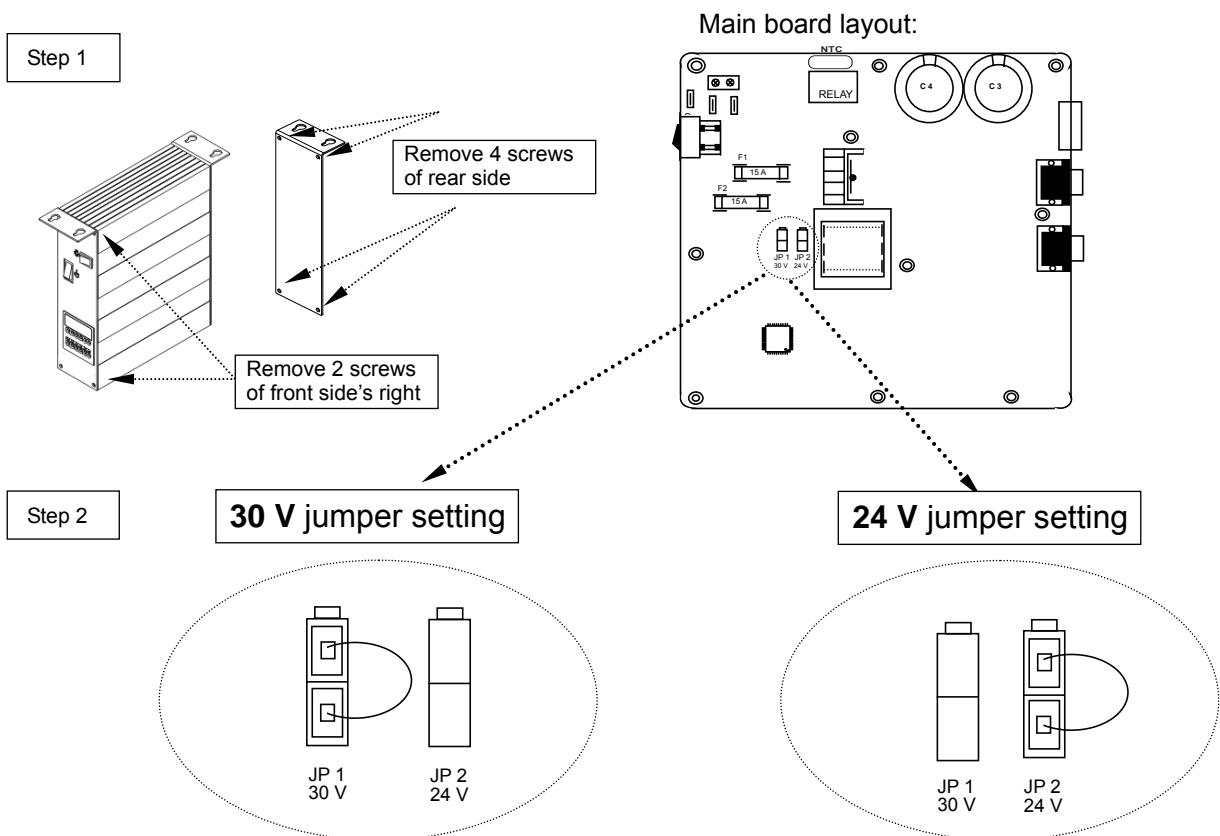

## 4. Diagrams Of Control Box:

(1). Front side:

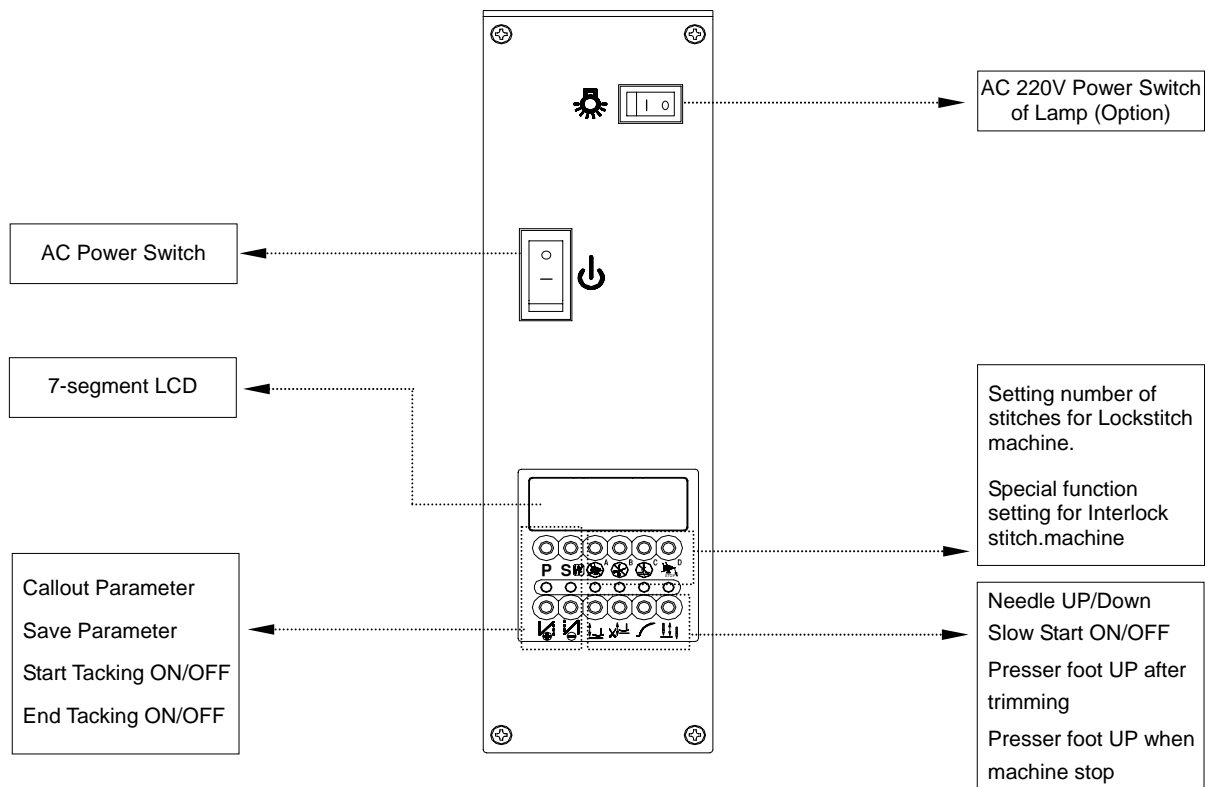

(2). Rear side: Connector Panel (Model sample : 70M-4-66)

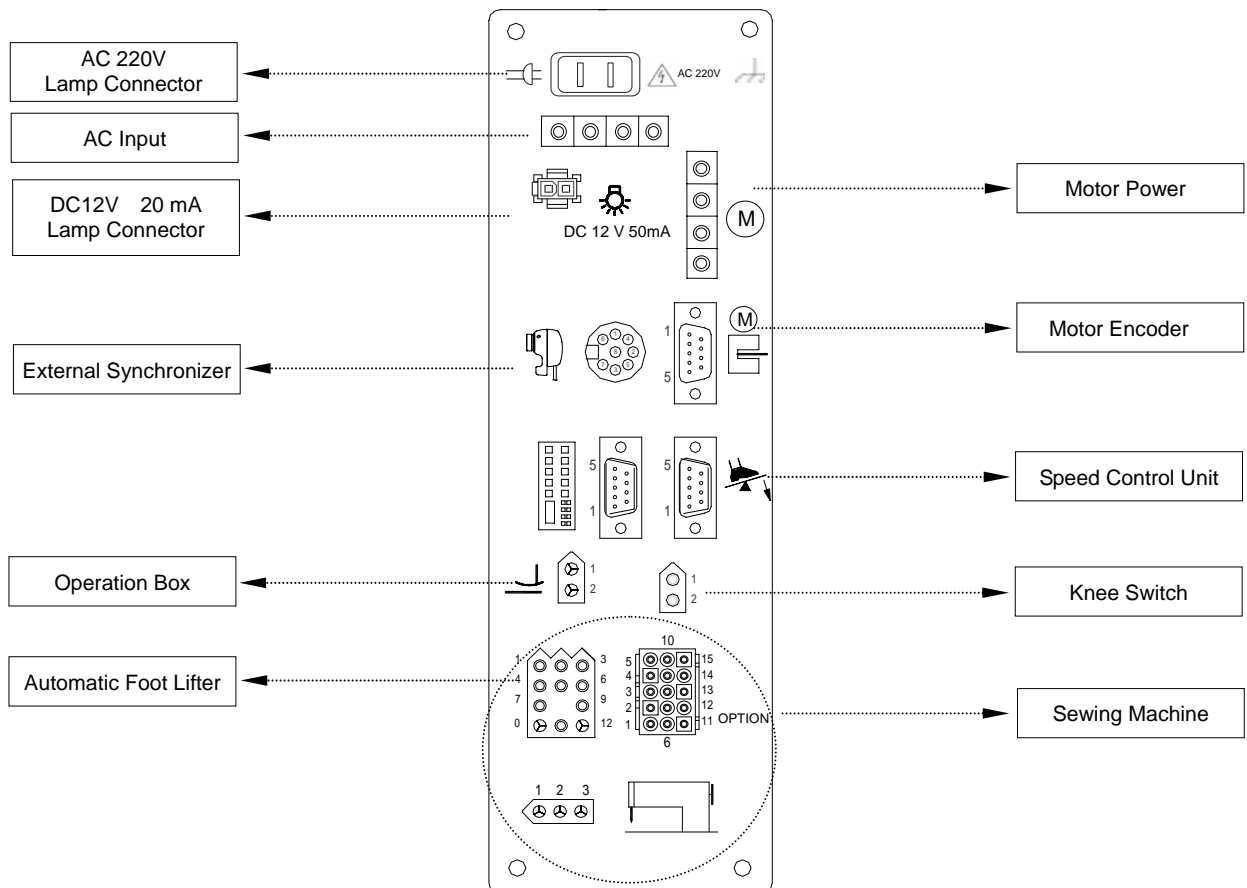

## 5. Programmable 7-segment Display:

(1). How to access the **【Normal Mode】** area:

Turn on the power and you can access the **【Normal Mode】** right away.

※ Under this mode, there are Lockstitch and Interlock stitch type displays different.

single phase voltage

Display showing when use Lockstitch machine.

Display showing when use

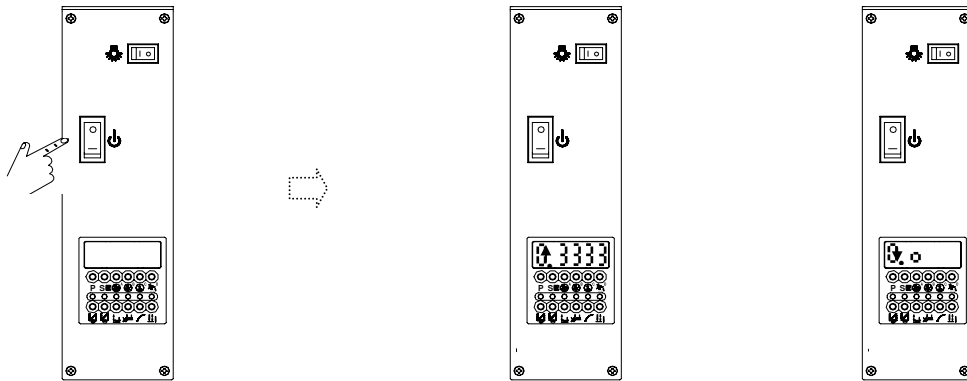

(2). Key functions in the **【Normal Mode】** on a lockstitch machine

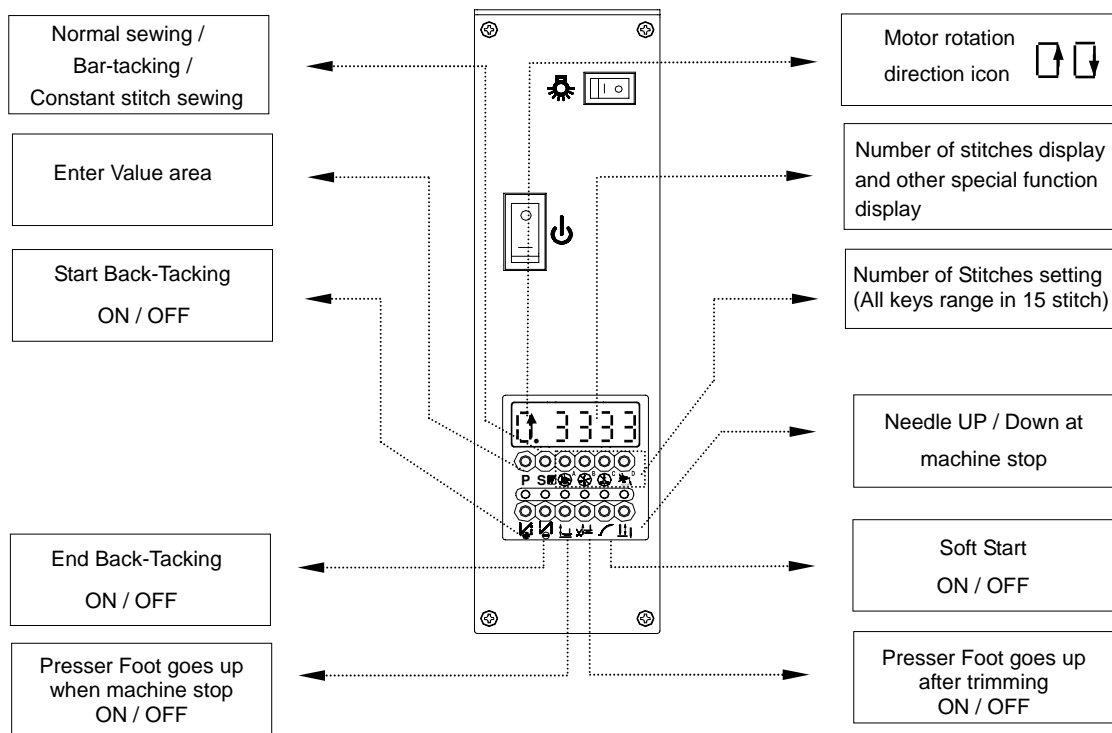

(3). Key functions in the **【Normal Mode】** on a interlock stitch machine

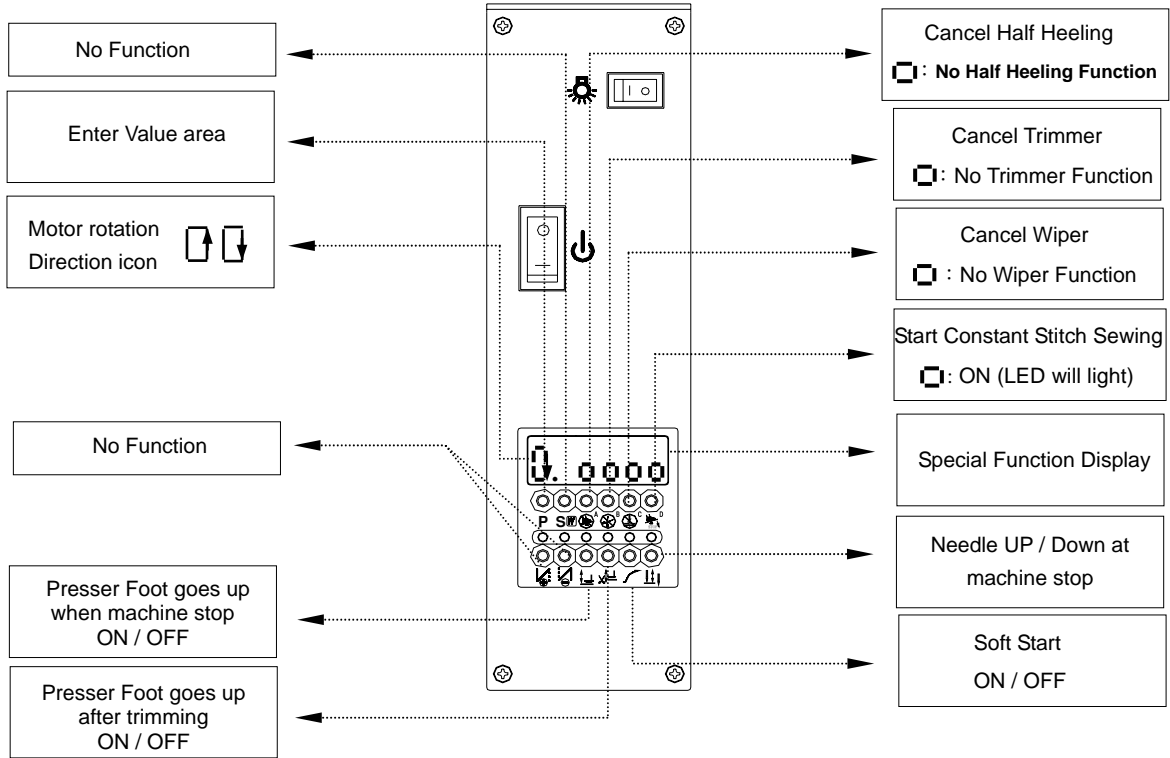

(4). How to perform 『BAR Tacking』 and 『Constant Stitch Sewing』 in the **【Normal Mode】**  
 Under **【Normal Mode】**, press key **[S]** can active and switch back and forth in normal sewing, Bar-tacking, and constant stitch sewing functions.

※ Unlisted keys are the same function as Lockstitch machine in normal mode.

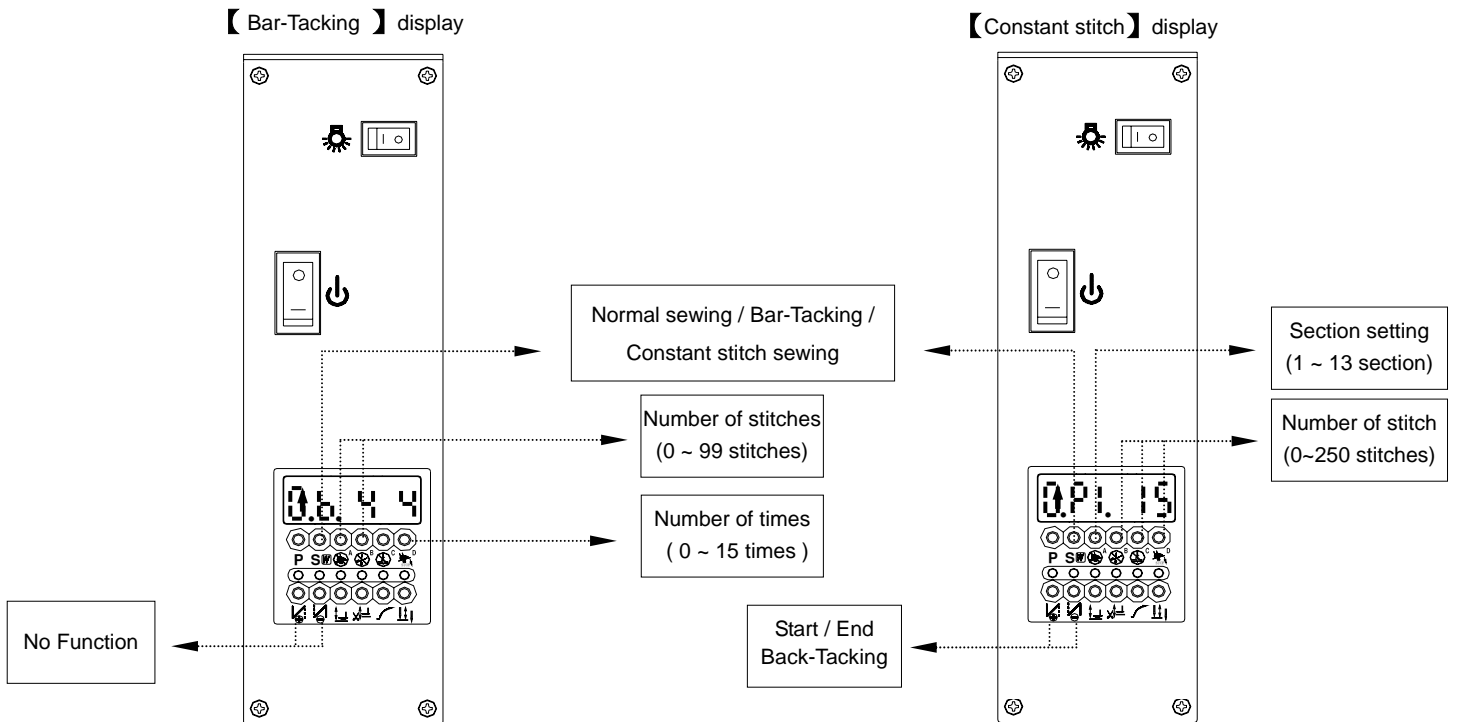



(5). How to access **【Parameter Mode A】** : ( Available parameter codes : 1 ~ 46 )

- a. Under **【Normal mode】** press key **P** will take you into the first parameter code **【 001. H 】** of **【Mode A】**
- b. Press or to get the parameter needed.. e.g.: **【002.SLM】**
- c. Press **S** to enter **【parameter value】**
- d. In this area, press key to make value adjustment.
- e. press **S** key to save the value.

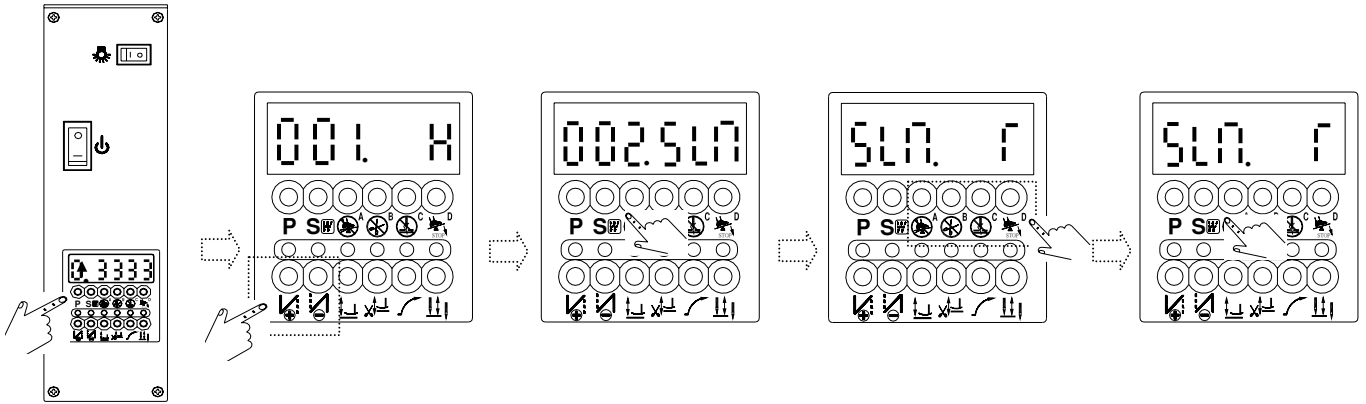

(6). How to access **【Parameter Mode B】** : ( Available parameter codes : 1 ~ 122 )

- a. Turn off the power
- b. Press hold **P** key and turn on the power to access the first parameter code **【 047.MAC】** of **【parameter mode B】**

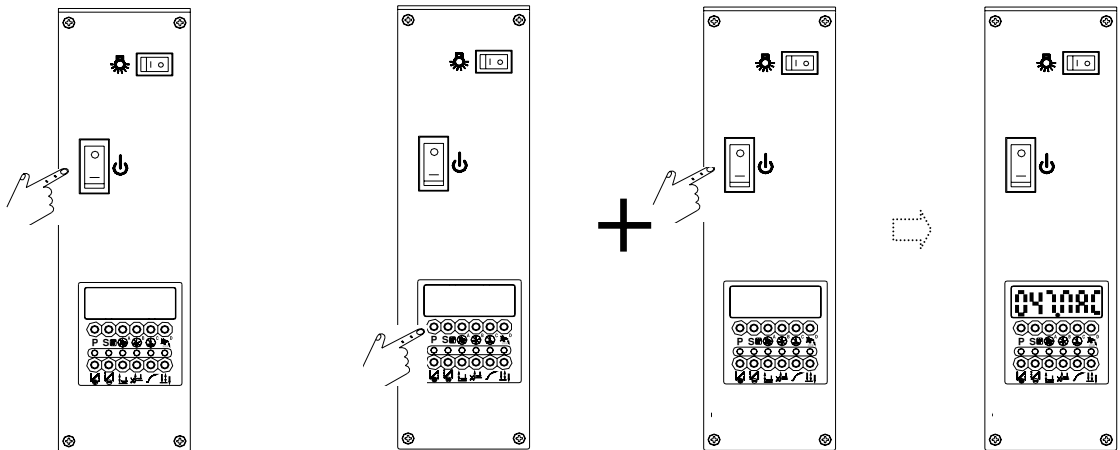

- c. Press or key to get the parameter code **【 048. N12】**
  - d. Use **S** key to enter **【parameter alue】**
  - e. In this area, press those key to make value adjustment.
  - f. Press **S** key to save the value.
- Note 1. After pressing **S** key, it will go back to **【Normal Mode】**  
 Note 2. Example: on Lockstitch machine

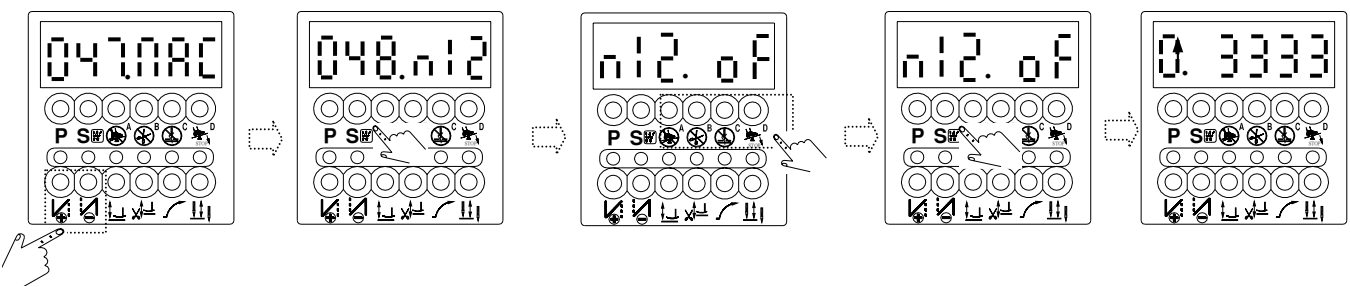

(7). Key functions in the 【Parameter Mode A and B】 : ( example as the following )

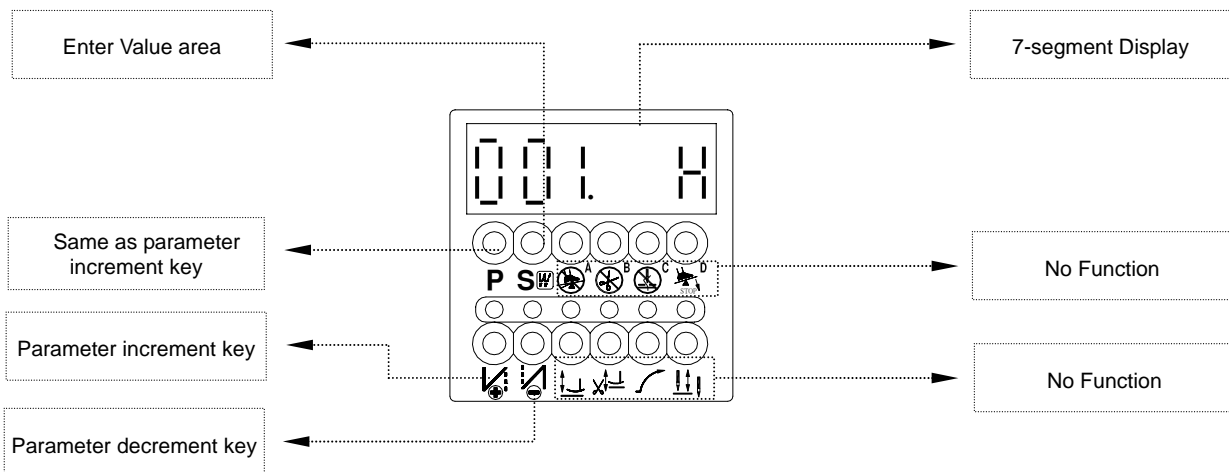

7-segment Display { In 【Mode A】 .First parameter showing is 【 001. H 】 .All available parameters start 1 ~ 46.  
 In 【Mode B】 .First parameter showing is 【 047. MAC 】 .All available parameters start 1 ~ 122.

(8). How to access the 【Parameter Value】 and adjust the setting

Step 1 : Confirm the parameter code you want to make adjust. ( see the parameter table for detail)

Step 2 : Follow the instruction to access parameter area and call out the parameter code.

Step 3 : Start making adjust parameter value. (Function selection use key and to make change. Speed, timing and angle setting can be set as the following : 【001. H】 value setting for your reference)

A). How to increase the default value :

Example : Factory default setting 【 H. 4500 】 increase to 【H. 5000】 .

See chapter 5, section (4) or (5) to learn how to access a - b - c value setting, then do the following step by step.

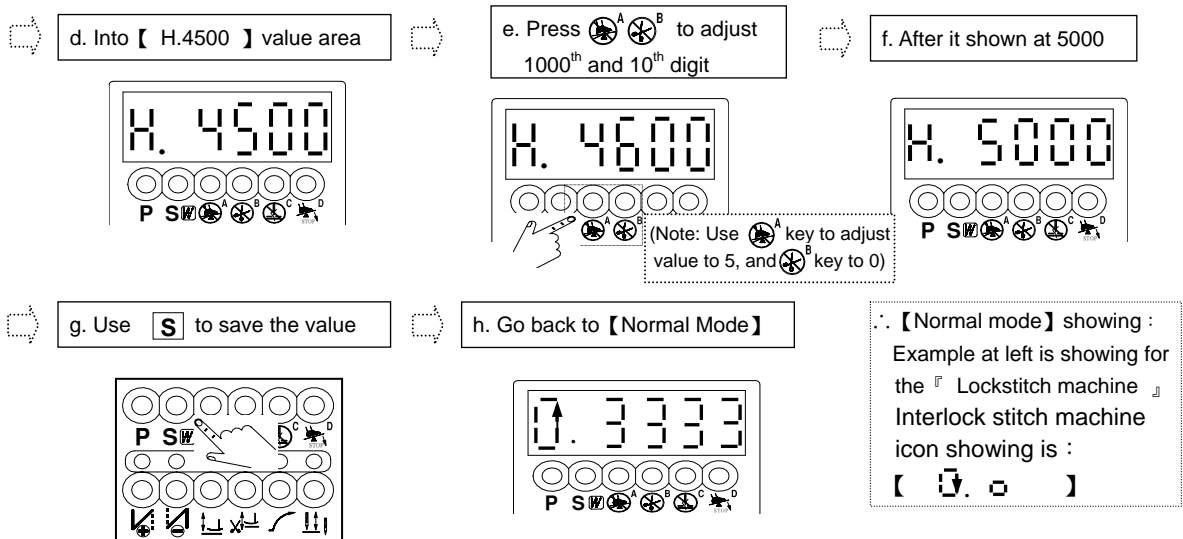

B). How to decrease the default value:

Example : Factory default setting 【H. 4500】 decrease to 【H. 4000】 :

See chapter 5, section (4) or (5) to learn how to access a · b · c value setting, then do the following step by step.



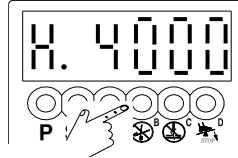
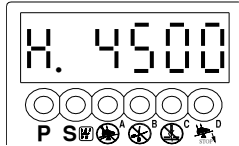

- d. Into 【H.4500】 value area      e. Press  to make return at 0

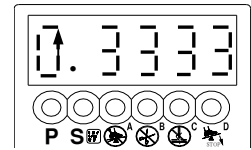
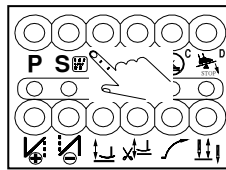
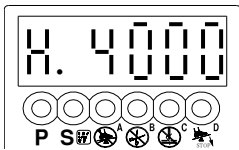

- f. After it shown at 4000 or any desire      g. Use **S** to save the value      h. Go back to 【Normal Mode】



(9). Value setting for A · B · C · D keys in the 【Parameter Value】 :

TERMS	KEY				
	VALUE				
IN TERMS OF SPEED		1000 spm	100 spm	10 spm	1 spm
IN TERMS OF ANGLE		-----	100 °	10 °	1 °
IN TERMS OF TIMING		1000 ms	100 ms	10 ms	10 ms
IN TERMS OF FUNCTION				FUNCTION SWAP	FUNCTION SWAP
∴ Other than the function selection, each press of the key will start change the value from 0 to 9					

**Note** : After value changed, press key **S** to save the value, otherwise they will lost after turning power off

## 6. General Parameter Table :

Mode	Parameter Code	Parameter Function	Range / Selection	Description / Note
A	001. H	Maximum sewing speed (spm)	50 ~ 9999	Maximum speed adjustments.
	004. N	Start Back-Tacking speed or Constant-Stitch speed for the Interlock Stitch machine (spm)	50 ~ 8000	Speed adjustment for Start Back-Tacking or Constant-Stitch sewing in the Interlock Stitch machine.
	005. V	End Back-Tacking speed (spm)	50 ~ 8000	Speed adjustment for End Back-Tacking.
	006. B	Bar-Tacking speed (spm)	50 ~ 8000	Speed adjustment for Bar-Tacking.
	007. S	Slow Start speed (spm)	50 ~ 2000	Speed adjustment for Slow Start.
	008. S L S	Number of Stitches for the Slow Start	0 ~ 99	Number of Stitches setting for Slow Start.
	009. A	Automatic Constant-Stitch sewing speed or Auto-start testing speed (spm)	50 ~ 8000	Speed adjustment for Automatic Constant-Stitch sewing. Note : Valid only when the 【 037. SMP 】 set on 『 A 』
	010. A C D	Automatic End Back-Tacking sewing (Can invalidate the Stitch Correction function)	ON / OFF	O N : After last seam of Constant-Stitch sewing, it will automatic execute the End Back-Tacking sewing function. Note : When turned on, the Stitch-Correction is invalid. OFF : Automatic End Back-Tacking will not execute after last seam, but can be done by pedal manually Note : The Stitch-Correction is valid in Free sewing, but the parameter 【011.RVM】 must set on 『 B 』.
	011. RVM	Back-Tacking Mode selection	J / B	J : JUKI mode ( Press TB switch will activate the reverse solenoid when either machine is stopped or running). B : BROTHER mode (Press TB switch will activate the reverse solenoid only when machine is running).
	040. W O N	Wiper function selection	ON / OFF	O N : Wiper valid. OFF : Wiper invalid.
	041. T M	Trimmer function selection	ON / OFF	O N : Trimmer valid. OFF : Trimmer invalid.
	045. S P	Sewing speed	0~8000	Showing the current sewing speed.
046. D I R	Direction of motor rotation	CW / CCW	C W : Clockwise. CCW : Counterclockwise.	
B	060. L	Low speed (spm)	50 ~ 500	Speed adjustment for Low speed.
	061. T	Trimmer speed (spm)	50 ~ 500	Speed adjustment for Trimmer.
	064. F O	Full-On time setting for Automatic Foot Lifter (ms)	0 ~ 990	Timing adjustment for Full-On time of Automatic Foot Lifter activates.
	065. F C	Duty-Cycle setting for Automatic Foot Lifter (%)	10 ~ 90	Adjustment for Duty-Cycle of AFL. (Fine tuning can reduce the over heating)
	066. F D	Running-Delay time setting (ms)	0 ~ 990	Running-Delay time adjustment for the Automatic Foot Lifter.
	070. H H C	Cancel Automatic Foot Lifting when Half-Heeling the pedal	ON / OFF	O N : Pedal half heeling without foot lifting function. (Only full heeling can activate Foot Lifer.) OFF : Pedal half heeling with foot lifting function.
	075. S F M	Safety switch mode	NC / NO	NO : Means Normal Opened. NC : Means Normal Closed.
	083. T 2	Trimming timing (ms)	0 ~ 990	Adjustment for trimming timing
	087. L 2	Tension release timing (ms)	0 ~ 1500	Adjustment for tension release timing.
	093. W 2	Wiper timing (ms)	0 ~ 9990	Adjustment for wiper timing.
	119. DD	Motor drive mode	ON / OFF	O N : Motor drive machine head directly OFF : Motor drive machine head with belt.
	121. A N U	Needle goes up automatically as power turned on	ON / OFF	O N : Power turned on, needle goes up position automatically. OFF : No Use.
	122. HL	Upper limit of maximum speed	50 - 9999	The motor's maximum speed setting.

## 7. Basic Troubleshooting :

### (1). Error Code and Measurement :

Error Code	Cause of The Problem	Status and Measurement
ER0. 4	<ol style="list-style-type: none"> <li>1. When power on, detected high voltage</li> <li>2. Connect the wrong voltage, too high.</li> </ol>	<p>Motor and machine will be shutting down. Please check the AC power. (Too high)</p> <p><b>* If control box is AC 220V system, don't use the AC 380V power voltage, otherwise the LED will display ER0. 4 after 2 second of power ON. If continue supply the 380V power, the electrolytic capacitors (C3,C4) of main board will burst open over a period of time and cause the fuses (F1,F2) of power input open circuit.</b></p> <p>Please check the main pc board.</p>
ER0. 7	<ol style="list-style-type: none"> <li>1. Bad connection at the motor connector.</li> <li>2. Synchronizer (sensor) signal error.</li> <li>3. Synchronizer is a single position type, and parameter set wrong type.</li> <li>4. Machine locked or object stuck in the motor pulley.</li> <li>5. Sewing material is too thick.</li> </ol>	<p>Motor and machine will be shutting down. Please check the motor or motor connectors' connection. Please check the Synchronizer (sensor) and its signal. Please check machine head to see if objects stuck in the motor pulley, or rotate not smoothly.</p>
ER0. 8	Operation Box linked to CPU interface had communication error	<p>Motor and machine will be shutting down. Please check the Operation Box.</p>
ER0. 9	<ol style="list-style-type: none"> <li>1. Machine solenoid shorted.</li> <li>2. Main board's power transistor is faulty.</li> </ol>	<p>Motor still can run, but all output signals and Operation box's pattern sewing function will be invalid.. Please check machine's solenoids or the resistance value is 2 Ω less. Please check all the power transistors which related to solenoid.</p>
ER0. 11	<ol style="list-style-type: none"> <li>1. If parameter 【121.ANU】 is set ON, but Auto Needle Up is malfunction when the power turned on.</li> <li>2. Machine locked or motor pulley have object stuck in it.</li> </ol>	<p>Motor still can run, but it automatic starts the clutch mode. All Constant-stitch sewing pattern and trimmer wiper function will be invalid. Please check Synchronizer's up position's signal. Please check main board's Synchronizer circuitry. Please check machine head to see if objects stuck in motor pulley, or rotate not smoothly.</p>
	<p>Motor rotation icon in LCD is halting and not moving.</p> <ol style="list-style-type: none"> <li>1. Safety switch is either faulty or bad connection. (For interlock stitch or blind stitch machine).</li> <li>2. Parameter 【075. SFM】 setting not match the machine head model.</li> </ol>	<p>Motor stops. Please check the safety switch. Please check parameter table on 【075. SFM】 setting, make sure it match machine head safety switch</p>

## (2). Instruction of Fuse Replacement

Fuse Type and Location : When fuse fused, find out the cause and fix it before replace the new one

Main Board Top View

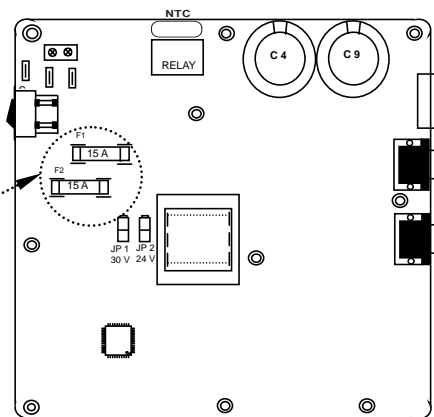

F1 / F2 Fuse is 15 A / 250V  
( For AC Power Protection )



**Caution :** Turn off the power and wait 10 minutes before opening box cover

(4) ε 70M Parts List :

**Motor Set Assembly**

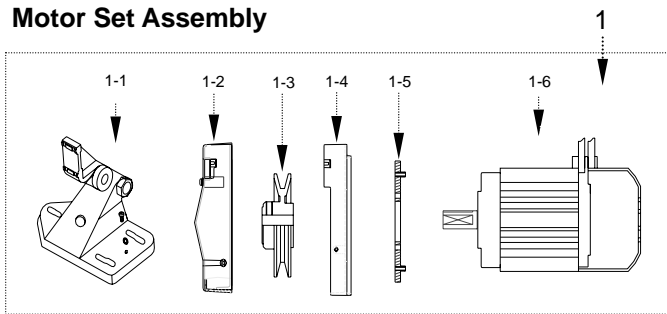

**Accessories**

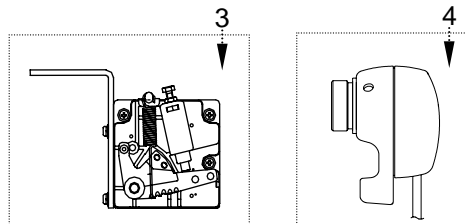

**Control Box Assembly**

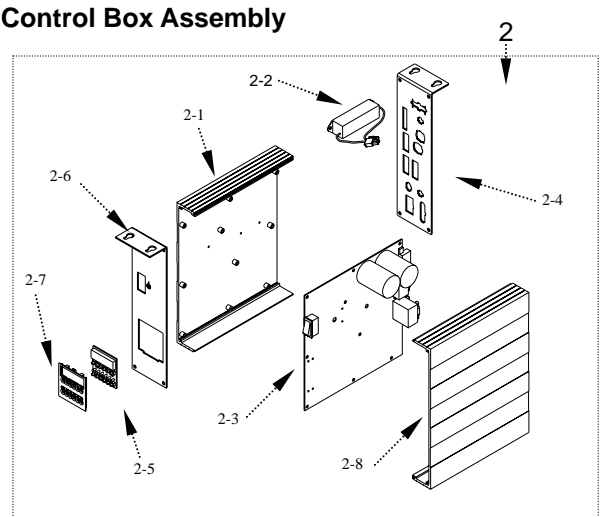

NO.	Order Code	Parts Name	Description	NO.	Order Code	Parts Name	Description
1	2VP34XX209XXX	Motor Set	Option	2- 2	2VP70304201	Cement Resistor	For ε 70M
				2- 3	2VP7M402001	Main Board	1 § 20 A
1-1	2VPBTV020	Motor Base	For V-Belt Type	2-4	2VP7M408BR001	Connector Panel	ε 70M -4-BR
1- 2	315BGV080	Belt Cover Top	For V-Belt Type		2VP7M4087W001	Connector Panel	ε 70M -4-7W
1-3	2VP2PY40XXX	Pulley	Option	2- 5	2VPPCB600	LED Panel Board	For ε 70M
1- 4	315BGV070	Belt Cover Base	For V-Belt Type	2- 6	312SMV320	Control Panel	For ε 70M
1- 5	313BGE030	Cover Bracket	For V-Belt Type	2- 7	2VP15MPB83001	LED Panel Plate	For ε 70M
1- 6	2VP34XX209XXX	Motor Body	Option	2- 8	2VP12MPB29102	Cover	For ε 70M
2	2VP7M400BR201	Control Box	200 ~ 240 V	3	2VP70306001	Speed Control Unit	For ε 70M
	2VP7M4007W201	Control Box	200 ~ 240 V	4	2VP11600XXXX	Synchronizer	Option
	2VP7M40066201	Control Box	200 ~ 240 V				
2- 1	2VP12MPB29101	Cover	For ε 70M				

# 8. CONNECTOR DIAGRAM

(1). 70M-4-66 : (V7) (07)

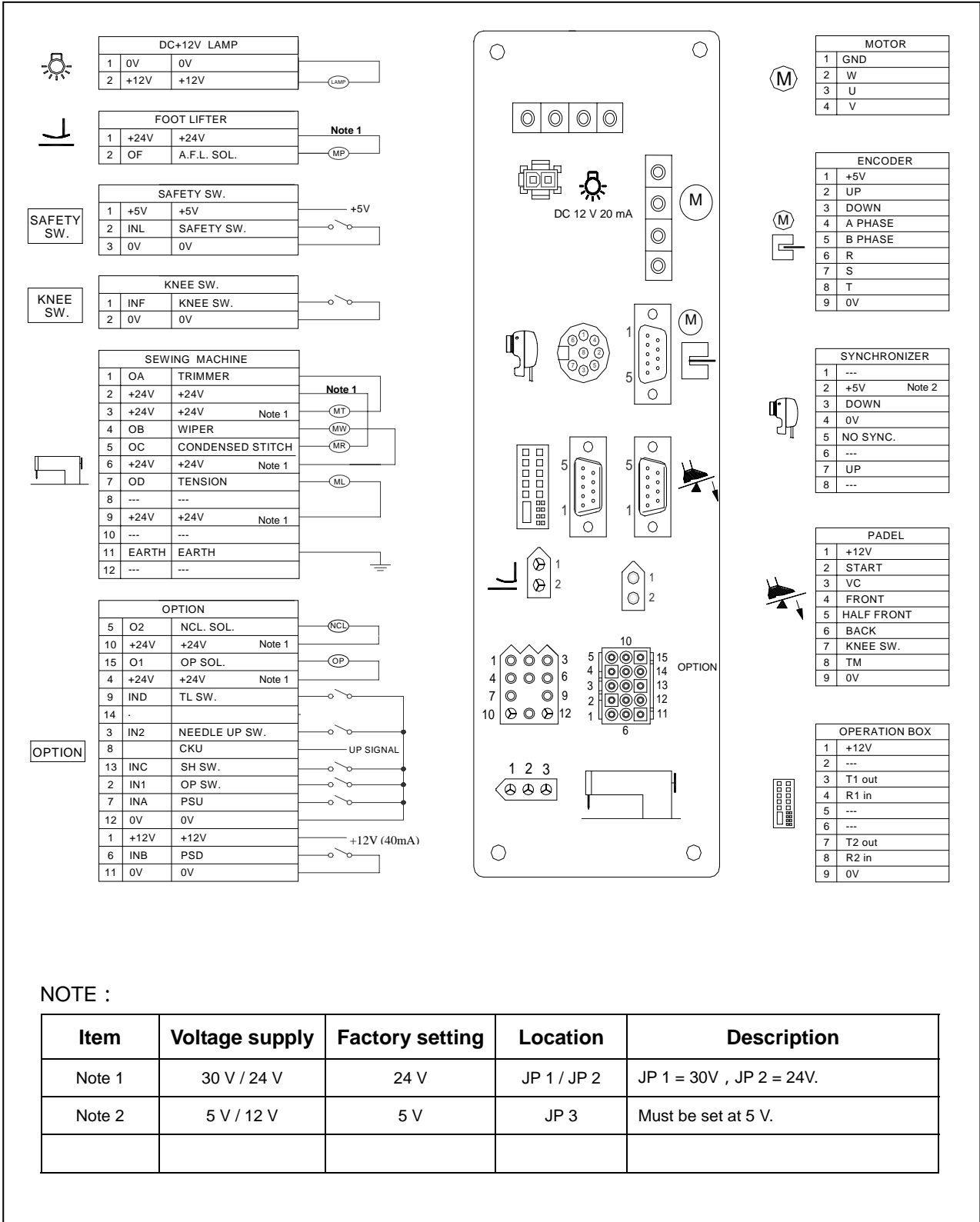

NOTE :

Item	Voltage supply	Factory setting	Location	Description
Note 1	30 V / 24 V	24 V	JP 1 / JP 2	JP 1 = 30V , JP 2 = 24V.
Note 2	5 V / 12 V	5 V	JP 3	Must be set at 5 V.



(2). e 70M-4-46 : (T2) (DW) (CT)

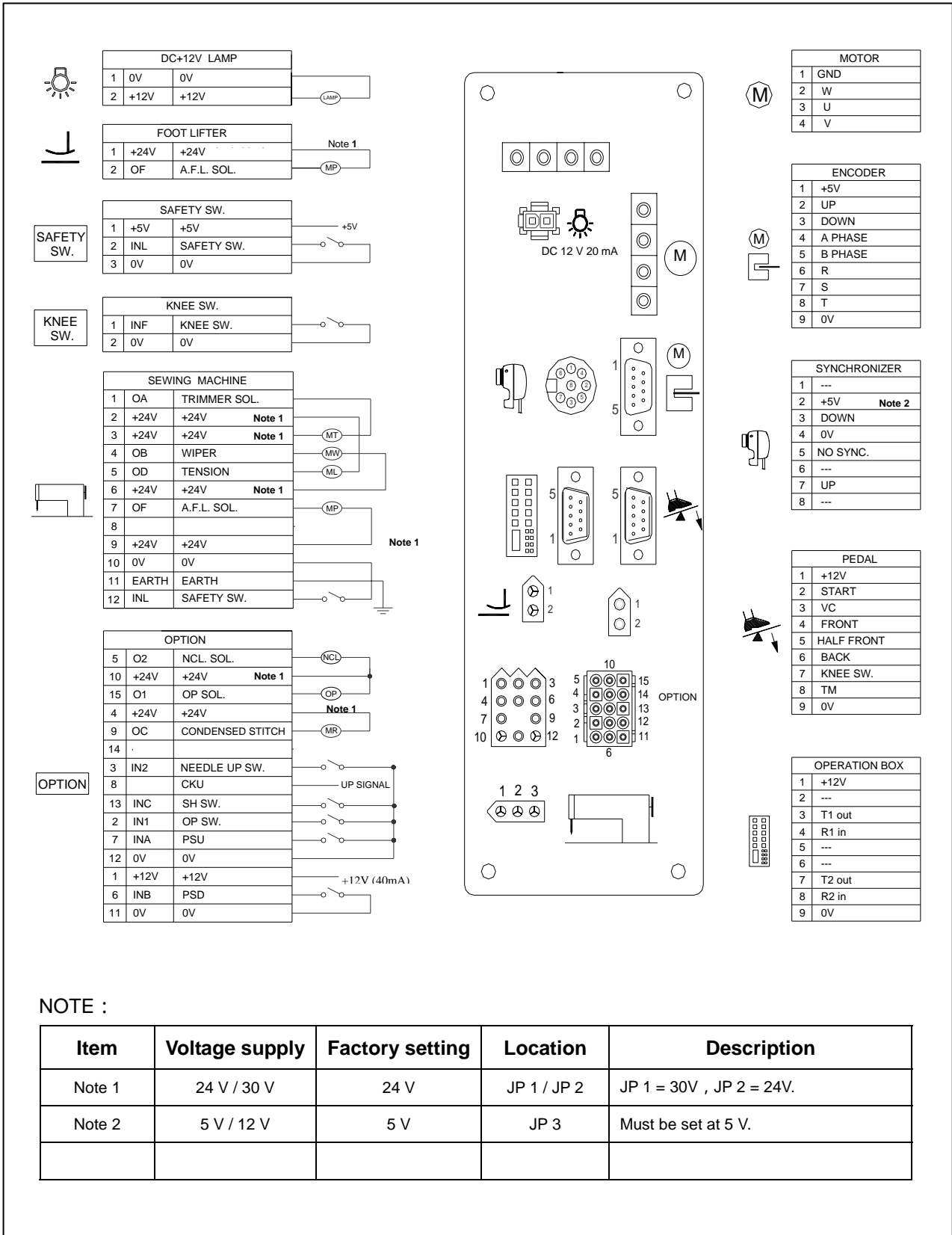























七段顯示器字體與實際數值對照表：

**7-Segment Display Characters Compare Table**

數值字體部份：(Arabic Numerals)

實際數值 (Actual)	0	1	2	3	4	5	6	7	8	9
七段顯示器 字 體 (Display)										

英文字體部份：(English Alphabet)

英文數字 (Actual)	A	B	C	D	E	F	G	H	I	J
七段顯示器 字 體 (Display)										
英文數字 (Actual)	K	L	M	N	O	P	Q	R	S	T
七段顯示器 字 體 (Display)										
英文數字 (Actual)	U	V	W	X	Y	Z				
七段顯示器 字 體 (Display)	