

G SERIES USER MANUAL

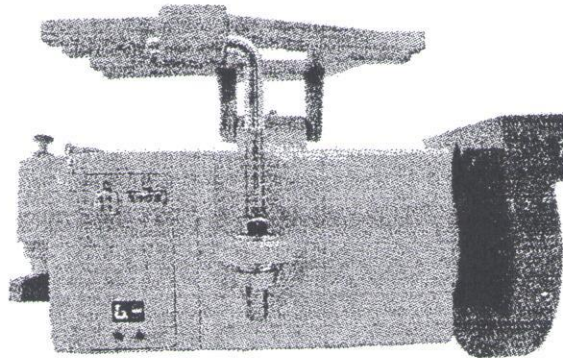

CONTENTS

1. Safety Precaution
2. Installation
3. Panel instructions
4. Parameter settings
5. Error Code List



H. S. Global Service Network
 SERVICE HOTLINE : +886-2-2676-5203
 FAX : +886-2-2689-6600, 2689-3657
 E-MAIL: service@hohsing.com.tw
 WEBSITE: http://www.hohsing.com

China Region
 SERVICE HOTLINE : +86-21-64901024
 FAX : +86-21-54570064
 WEBSITE : http://www.hohsing.com



HSVPG1U01-0

2012.02

EC Declaration of Conformity

We hereby declare that the following products:
 AC servo motor-G series
 are in conformity with the provision of the EC directives
 as following :

- EC Low Voltage Directive (2006/95/EC)
 - EC Electromagnetic Compatibility Directive (2004/108/EC)
 - EC Machinery Directive (2006/42/EC)
- Applied harmonized standards :
 EN 60204-31 : Electrical equipment of industrial machines. Particular requirements for sewing machines, sewing units and sewing system.
 EN 292-1 : Safety of machines.
 EN 292-2 : Safety of machines, technical guidelines and specifications.
 EN 61000-6-2 : EMS for industrial environment.
 EN 61000-6-3 : EMI for residential environment.

Declaration of Conformity for Concentration Limits for Certain Hazardous Substances

We hereby declare that the following products:
 AC servo motor- G series
 are complies with the following directives and requirements :

1. European Union RoHS Directive (2002/95/EC) and the concentration limits for certain hazardous substances (2005/618/EC)
2. People's Republic of China Electronic Business Standard : Requirements for concentration limits for certain hazardous substances in electronic information products (SJ/T 11363-2006)

Our product itself (motor, control box) or its packing materials and accessories (box, screws package, user manual, sticker, label, print... etc.) or the suppliers of parts and raw materials are all in conformity with the provision of the European Union RoHS Directive and People's Republic of China Electronic Business Standard to conform the following concentration limits for the six hazardous substances :

Hazardous Substance	Permissible Values
Lead (Pb)	Less than 240 ppm
Mercury (Hg)	Less than 800 ppm
Cadmium (Cd)	Less than 80 ppm
Hexavalent chromium (Cr VI)	Less than 800 ppm
Polybrominated Biphenyl (PBB)	Less than 800 ppm
Polybrominated Diphenyl ether (PBDE)	Less than 800 ppm

- * The concentration of lead in the lead-free process for PCB shall be less than 800 ppm.
- * For packing materials shipped with our products or parts, the hazardous substances shall be 80 ppm or less in sum of Pb+Hg+Cd+Cr VI.

H. S. Machinery. Co., Ltd.

Mr. C. C. Lee
 Plant Manager

1. Safety Precaution :

Please read this manual with sewing machine manual thoroughly and pay attention for the following safety precaution.

- Installation and operation must be done by the trained personnel, also turn off the power switch and remove the plug from outlet and wait for 5 minutes before any installation.
- This product is designed for the specific sewing machines and must not be used for other purposes.
- Only use the power voltage as described on the name plate of the motor and control box in $\pm 10\%$ ranges.

⚠ Attention : If the control box is AC 220V system, please don't connect to the AC 380V power outlet, otherwise the error will occur and motor is not functional. If that happened, please turn off the power switch immediately and check the power voltage. Continue supply the 380V power over 5 minutes might damage the fuses and burst the electrolytic capacitors and even might endanger the person safety.



- In order to prevent abnormal operation, keep the product away from the high frequency machines.
- Don't operate in direct sun light - outdoors area and the room temperature is 45°C above or 5°C under.
- Don't operate near the heater - dew area and the humidity is 30 % less or 95% more.
- Don't operate in dusty - evaporate - combustible gas area, and stay away from corrosive material.
- Don't apply heavy objects or excessive force on the power cord, also don't bend or pull the power cord.
- Power cord must keep 3 cm or above distance away from the V-belt and the pulley.
- In order to prevent the static interference and current leakage, all grounding works must be done properly.
- After power on the machine for the first time, use low speed to operate and check the correct rotation direction.
- During machine operation, don't touch any moving parts.
- All moving parts must have protective device to avoid the body contact and objects insertion.
- Maintenance and repair must be done by the properly trained technician, also all the spare parts for repair must be approved or supplied by the manufacturer.
- Don't use any objects or force to hit or ram the product.

Danger and caution signs



Risks that may cause personal injury or risk to the machine are marked with this symbol in the instruction manual.



This symbol indicates electrical risks and warnings.

Limited Warranty

Warranty period of this product is 1 year from purchasing, or 18 months from our manufacturing date.

Warranty Detail

Any trouble found within warranty period under normal use condition in conformance with this manual, it will be repaired free of charge. Repair will be chargeable in the following cases even if within warranty period :

1. Inappropriate use include: wrong connecting high voltage, wrong application, disassemble, repair, modification by incompetent personnel, or operate the product without the precaution, or operate the products out of its specification range. Insert odd objects or liquids into the product.
2. Damage by fire, Earth quake, lightning, wind, flood, salt corrosive, moisture, abnormal power voltage and any other damage cause by the natural disaster or by the inappropriate environments.
3. Dropping after purchase, or damage in transportation by customer himself. (or by customer's shipping agency)

Note : We put our best effort and mind in testing and manufacturing for assuring the quality and reliable of this product. But it is possible this product can still be damaged due to external magnetic interference and electronic static or noise or unstable power source more than expected; therefore the grounding system of operate area must be well-connected to this product and it's also recommended to install a failsafe device.

2. Installation :

a). Install the motor and control box under the table

G installation

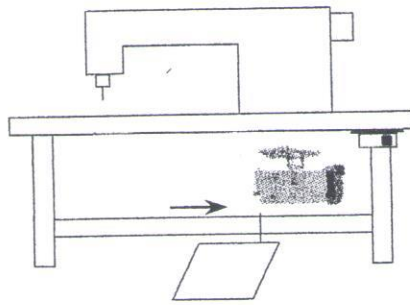
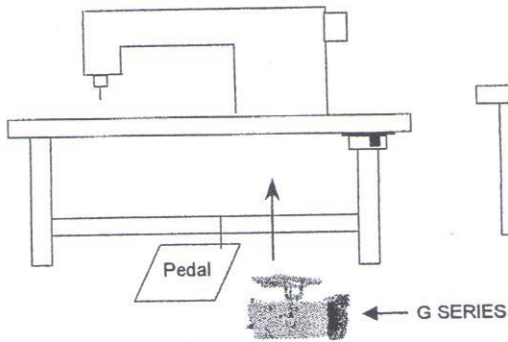

c). Install the V-Belt on the motor and machine pulley, then adjust the belt to its appropriate tension.

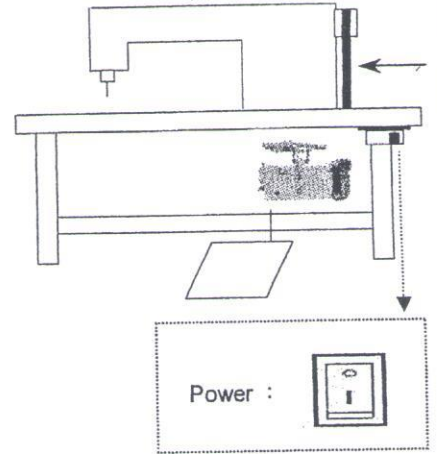

Synchronizer installation



Caution :
For person safety, turn off the power switch and remove the power plug from outlet before any adjustment.

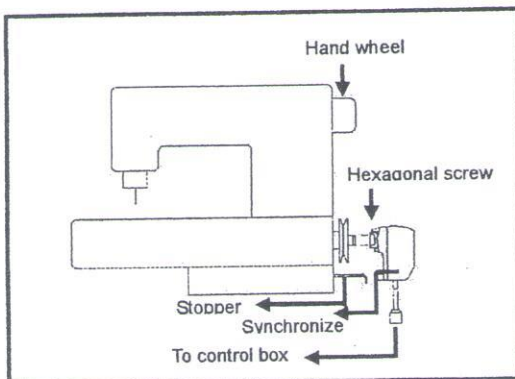

Synchronizer Adjustment (Please open the top cover first)

Needle up position : Rotate the machine pulley to reach mechanical needle up position and turn the photo disc (A) until its red mark is aligned with the red mark on the bearing cover plate.

Note: Instruction above is the standard adjustment. If you feel the position wasn't accurate, please do the fine tuning by yourself.

Mounting the Synchronizer onto the flange of hand wheel and match the stop groove of the synchronizer with the stopper of the machine head then tighten and secure 2 hexagonal screws of the synchronizer rotor, then connect the synchronizer cable to the control box.

Note : Stopper type and location might be varied, depend by the machine model.

Setting screw
Bearing cover plate
Photo disc (A)

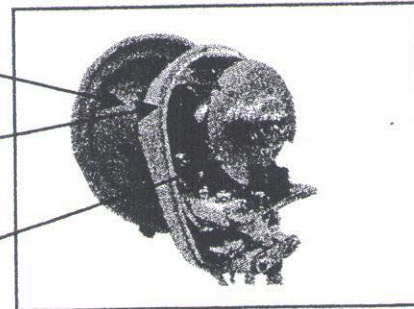

Speed control unit adjustment



Caution :

For person safety, turn off the power switch and remove the power plug from outlet before any adjustment.

Components of speed control unit : see figure

- A : Spring for toeing forward force adjustment
- B : Bolt for heeling backward force adjustment
- C : Pedal arm
- D : Pitman rod for pedal

	Term of adjustment	Adjustment result
1	Toeing forward force adjustment	Spring A move to right = force increased Spring A move to left = force decreased
	Heeling backward force adjustment	Bolt B turn = force decreased Bolt B turn = force increased
3	Pedal stroke adjustment	Rod D secure at right = stroke is longer Rod D secure at left = stroke is shorter

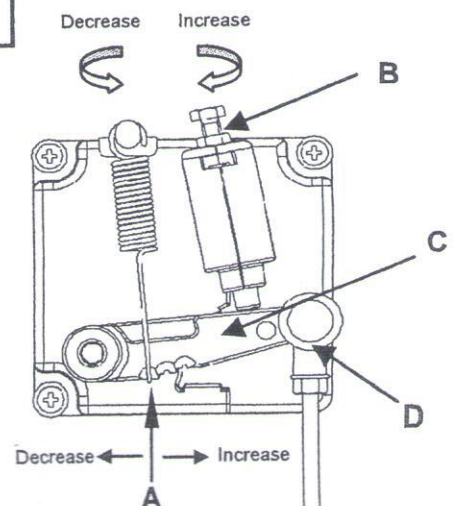

3. Panel instructions

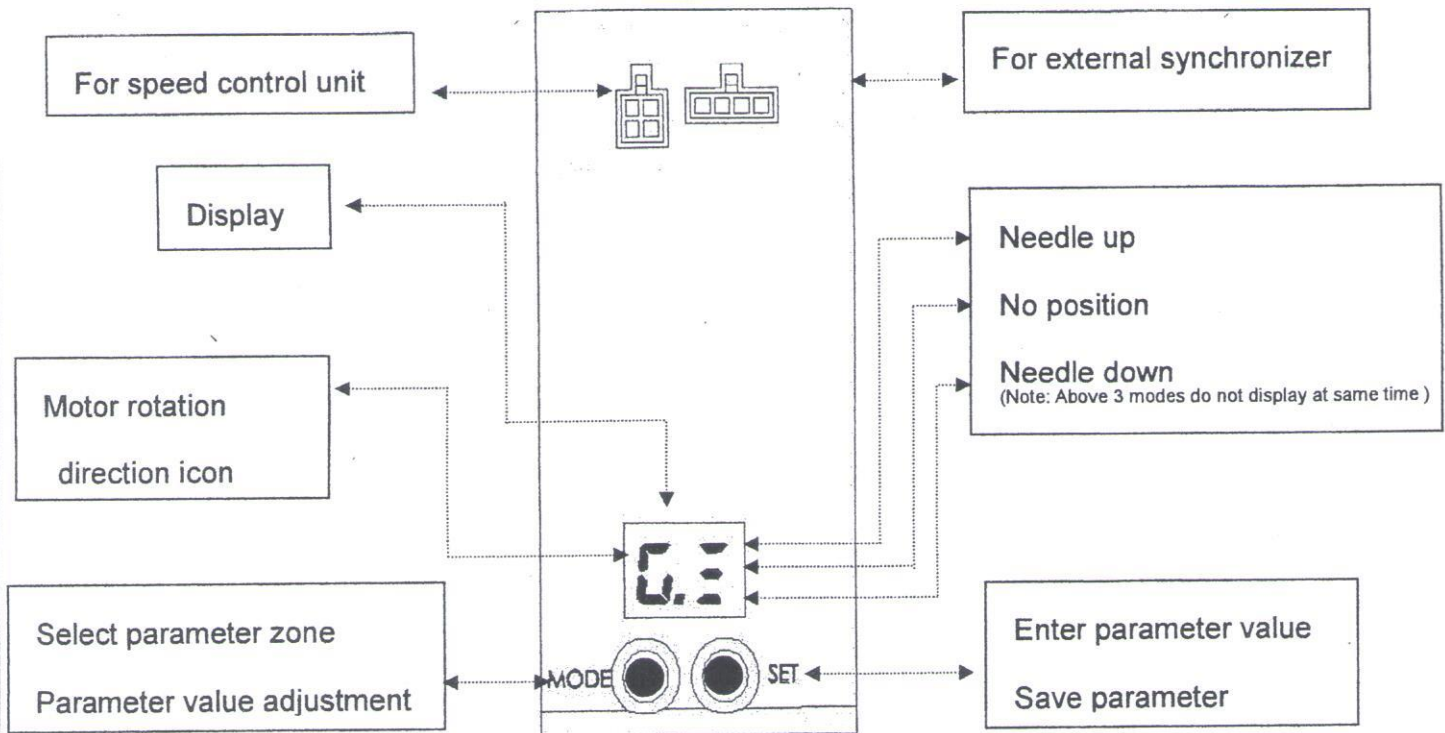

3.1 Motor direction setting:

Press the " MODE ● " and turn on the power  at same time . Enter the setting mode , press "MODE ● " key to select C(CW) / CC(CCW). Press " ● SET" key to save.

3.2 How to set needle position while fixed the synchronizer :

Press the " ● SET " key and turn on the power  at same time. Enter the setting mode , press "MODE ●" key To select UP / DOWN , press " ● SET" key to save.

3.3 Adjust step at parameter zone:

Step1: Press "MODE" key to enter setting mode.

Step2: Press "MODE" key select the parameter you want to adjust.

Step3: Press "SET" key enter the parameter value adjustment.

Step4: Press "MODE" key increase the value.

Step5: Press "SET" key to save.

4. Parameter settings

Parameter NO.	Function Name	Range	Value	Lockstitch	Over lock	High Post	Twin needle	Cover stitch
P0	Maximum sewing speed	1~65	*100spm	40	60	15	20	40
P1	Low speed	10~50	*10spm	23	25	23	23	25
P2	Motor's pulley dimension	50~G0	*1m/m	90	90	65	75	A0
P3	Machine's pulley dimension	50~G0	50 ~ 160	75	55	65	80	65
P4	Pulley's ratio setting mode selection	ON/OFF	ON: Refer to P2.P3 OFF: Calculate Automatically	OFF	OFF	OFF	OFF	OFF
P5	Sewing speed	-----	-----	---	---	---	---	---
P6	Virtual down A position edge angle	9~30	*10 ⁰	18	18	18	18	18
P7	Slow start operation mode	ON/OFF	ON: Valid OFF: Invalid	OFF	OFF	OFF	OFF	OFF
P8	Soft start speed	10~50	*10spm	40	40	20	40	40
P9	Stitch numbers for soft start	1~9	*1 Stitch	2	2	2	2	2
PA	Soft start at the first cycle of power ON	ON/OFF	ON: Slow speed at first stitch OFF: Refer to P7	OFF	OFF	OFF	OFF	OFF
PB	Motor braked at normal stop	ON/OFF	ON: Locked OFF: Unlocked	OFF	OFF	OFF	OFF	OFF
PC	Weak braking torque scale	0.1~5.0	Ampere value	2.0	2.0	2.0	2.0	2.0
PD	Acceleration time	10~50	*10ms	40	30	30	40	30
PE	Deceleration time	10~50	*10ms	22	26	26	22	26
FL	Recovery to factory setting	Y/N	Y: Recover factory presetting N:-----	---	---	---	---	---
FS	Save factory setting	Y/N	Y: Saves factory presetting N:-----	---	---	---	---	---

5. Error Code List :

Error code	Cause of the problem	Condition and solution
E.4	1. When power on, higher power voltage has been detected. 2. Connect to a wrong AC power source.	Motor and machine will be shutting down. Please check the AC power source.
E.7	1. Bad connection to the motor connector. 2. Synchronizer (sensor) signal error. 3. Machine locked or object stuck in the motor pulley. 4. Sewing material is too thick.	Motor and machine will be shutting down. Please check the synchronizer (sensor) and its signal. Please check machine head to see if any objects stuck in the motor pulley, or machine does not rotate smoothly.
E.P	Power on, speed control unit is not at neutral position.	Speed control unit return to neutral.