

GLOBAL

Our experience. Your success

GLOBAL

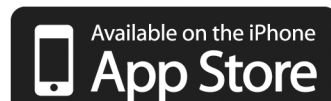

- 1). The mechanical fullness control by operating the knuckle switch at the needle-bar end of the machine, the two amounts of fullness set on the scales can be alternated at
- 2). High-speed seamer with differential feed and variable top feed , and with automatic presser foot lifter & edge guide & tape guide & tape reel bracket.
- 3). Stay tape and sewing threads are cut manually on a hook knife fitted to the presser foot.
- 4). Breakdown of an intricate operation simple ones, absolute dimensional accuracy and consistently high quality.

SPECIFICATION:

- MAX. SEWING SPEED:2,000 S.P.M.
- BASIC STITCH LENGTH:2mm
- MAX. GATHERING STITCH LENGTH:8mm
- NEEDLE SYSTEM: DPX17#16~#19
- HOOK SIZE: LARGE FULL ROTATION

***CAUTION:**

In-rush operation (In-rush operation is required for a new sewing machine, or when the sewing machine left out of operation for considerable length of time is used

- 1). Recoil through the holes instructed by arrow in Fig 3.
- 2). Lift the presser foot.
- 3). Run the sewing machine at a low speed (1,500~2,000rpm) for 30 minutes.

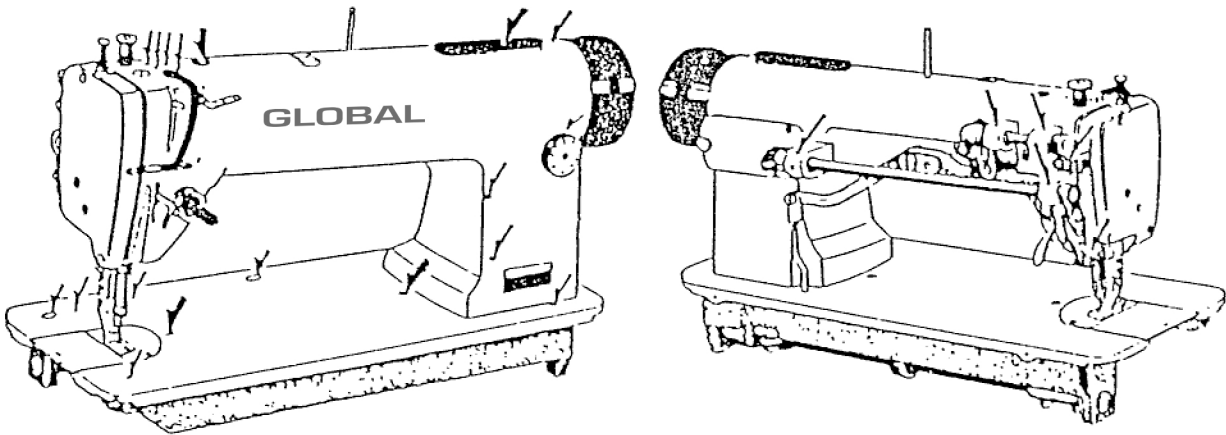
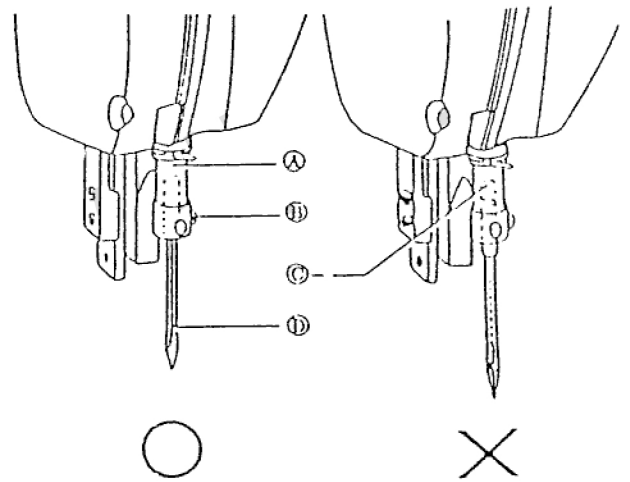

Fig 1

—). OPERATION

1-1. Replacing the needle

- 1) Lift Needle Bar (A) to the upper end Of its stroke.
- 2) Directing Prime Groove (longer groove) (D) of the needle leftward, fully insert the needle shank into Needle Socket (C).



- 3) Tighten Needle Set Screw (B)

1-2. Winding the bobbin thread

- 1) Install Bobbin (A) to Bobbin Winder Spindle (B)
- 2) Pass Thread (C) in the order (1, 2) indicated in Fig 3 and wind it upwardly 2 or 3 turns on the bobbin.
- 3) Push Bobbin Winder Stop Latch Lever (D) ahead to lock the bobbin.
- 4) Start the sewing machine
- 5) When the thread is fully wound, the bobbin winder- stop-latch automatically release the bobbin ,thus stopping the winding motion

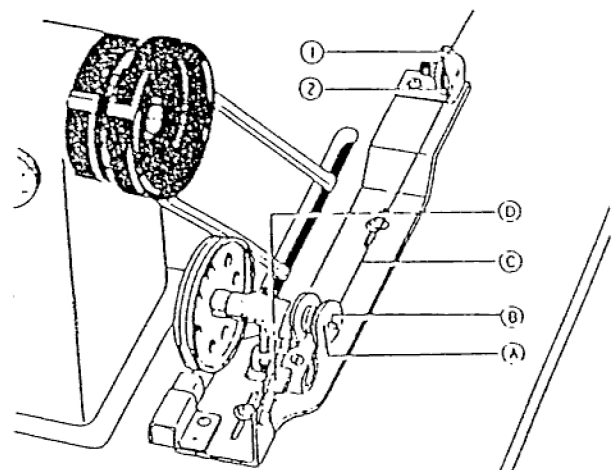

1-3. Cautions on handing the bobbin winder

1) Thread winding tension can be adjusted by turning Adjust Screw (A) of the bobbin winder tension bracket.

2) Length of thread wound on the bobbin can be adjusted by Bobbin Winder Stop latch Adjust Screw (E).

3) When the wound thread layer does not present a cylindrical shape (A) in Fig 5, loosen Bobbin Winder Tension Bracket Mounting Screw (B) and slide Bracket (C) leftward or rightward to locate the bracket in line with the thread.

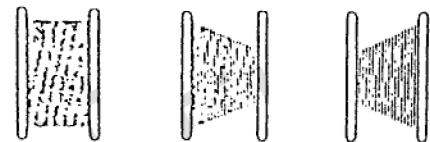
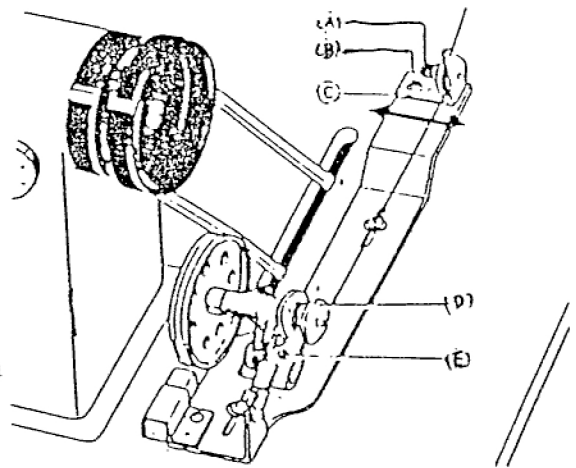

3) If thread is wound as show by (B) in Fig 5, move the bracket rightward. If thread is wound as show by (C) in Fig 5, move the bracket leftward.

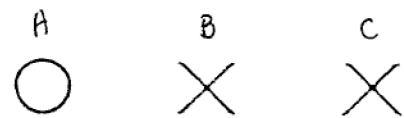

1-4. Setting the bobbin

1) Put Bobbin (B) into Bobbin Case (A)

2) Pass the thread through Slit (C) to lead it out From outlet (D).

3) Make sure that the bobbin rotates clockwise when the thread is drawn. If the bobbin rotates counter-clockwise, reverse Bobbin (B).

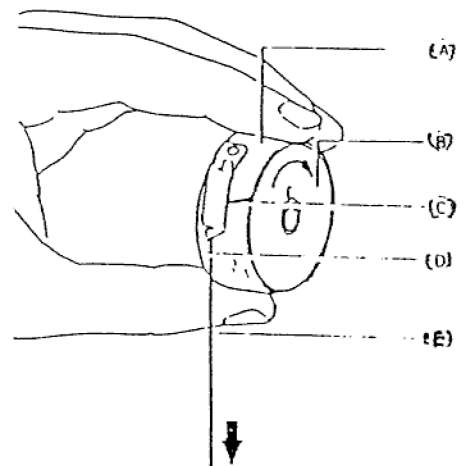

1-5. Installing the bobbin case

1) Lift the needle bar to the upper end of its stroke and open the slide plate.

2) Fully lift Bobbin Case Latch Lever (A) and holding the lever by finger, securely install the bobbin case into the rotating hook (B)

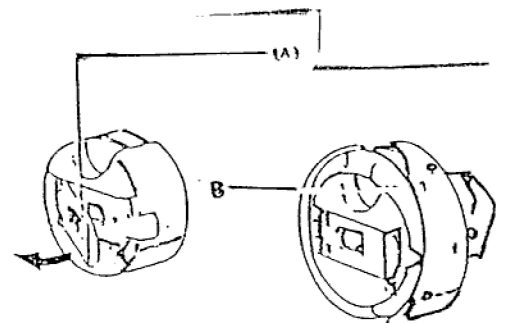

1-6. Threading the needle thread

- 1) Raise the thread take-up lever to the upper end of its stroke.
- 2) Pass the thread in the order numerically instructed in Fig 8.

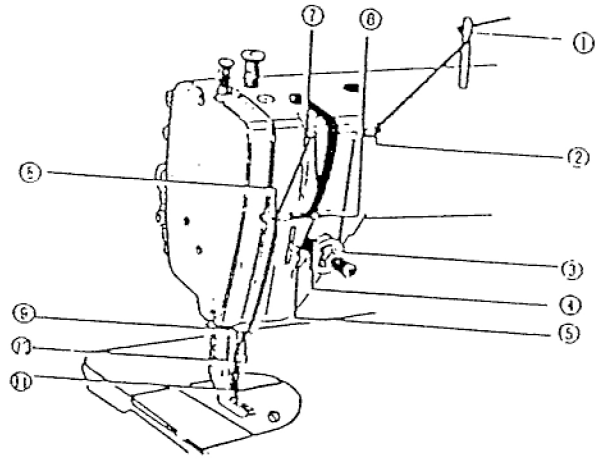

1-7. Adjusting needle thread tension

To adjust tension of the needle thread,
Turn tension regulating thumb (A)
By turning the nut clockwise, needle
thread tension increases.
By turning the nut counter-clockwise
needle thread tension decreases.

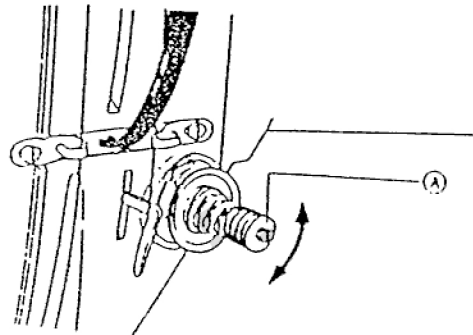

1-8. Adjusting bobbin thread tension

To adjust tension of bobbin thread,
Turn tension regulating screw (A)
By turning the screw clockwise, the
bobbin thread tension increases.
By turning the screw counter-clockwise,
the bobbin thread tension decreases.

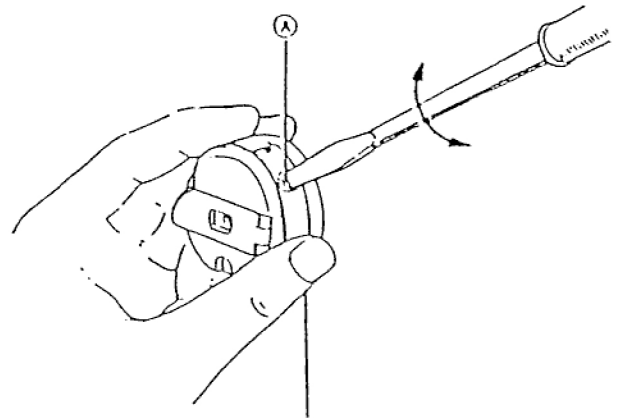

1-9. Setting the stitch length

- 1) Stitch length can be set by turning
Dial for Stitch Length Regulator (B)
- 2) The number figures (B) on the dial
show the stitch length in mm.

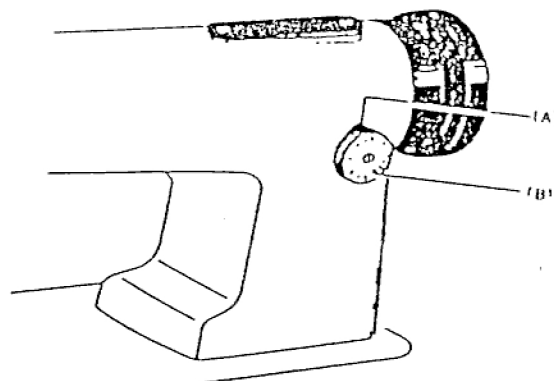

1-10. Threading the stabilizing tape

Thread the stabilizing tape according to Fig12.

1).Regulating the tension of the stabilizing tape

To increase the tension turn milled nut (A) clockwise, to decrease it turn the nut anti-clockwise.

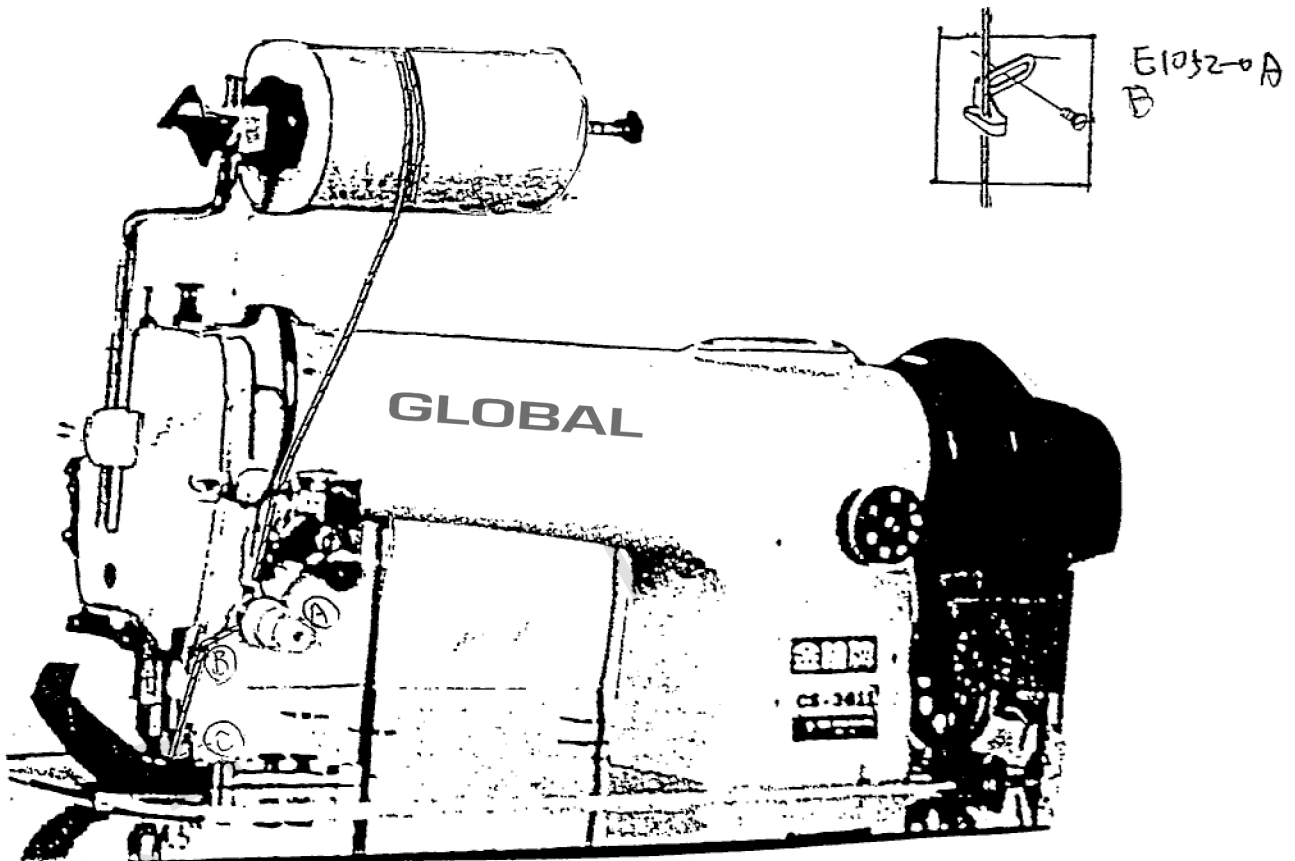
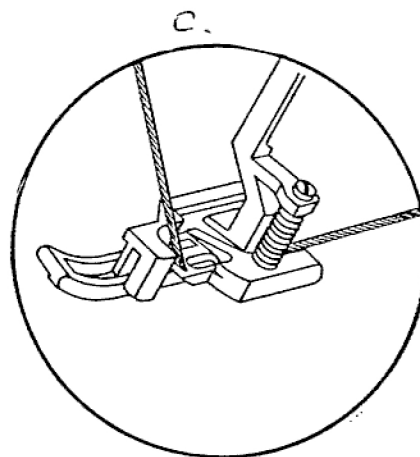
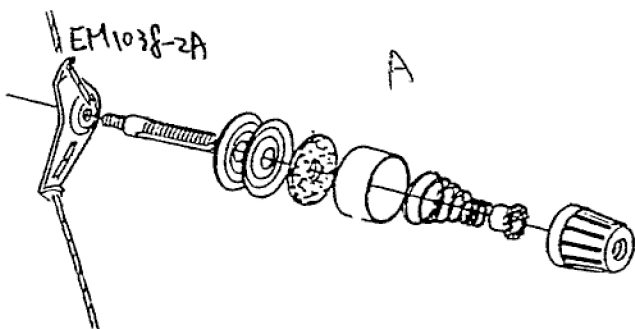

Fig 12



二) Working in fullness

Various degrees of fullness can be set by adjusting the dial plate (Fig13).

The higher the figure set the greater the amount of fullness.

The settings have to be worked out individually.

Working in two amounts of fullness alternately by operating the push bottom

GL 3811. When the bottom light is on the two amounts of fullness are working, the bottom light is off the two amounts of fullness are closed.

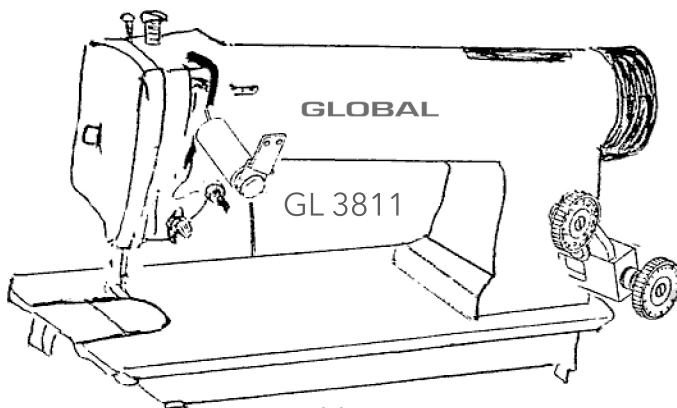
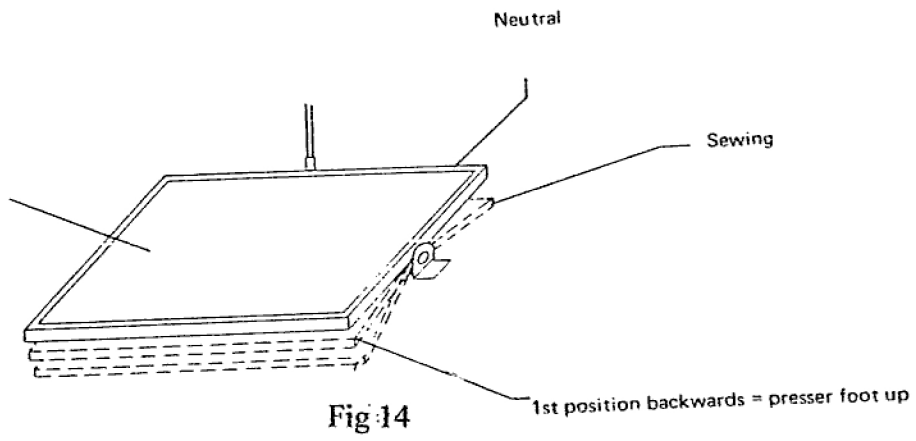

Fig13

三). Sewing

- 1). Switch on the machine
- 2). To raise the presser foot, press pedal back to the first position (Fig14)
- 3). Place the workpiece under the needle and push it to the right as far as it will go.
- 4). To lower the presser foot again, release the pedal (neutral)
- 5). To start the sewing action press the pedal forwards. The sewing speed is determined by the position of the pedal.
- 6). During the sewing action, fullness can now be applied as described in section
- 7). At the end of the seam press the pedal fully backwards, the sewing machine stops, the presser foot is raised.
- 8). Switch off the machine



- **CLEANING THE MACHINE**

Clean the entire machine regularly & oiling the sewing machine