



# GLOBAL

## CB SERIES

### Instruction & Parts manual

[www.globalsew.com](http://www.globalsew.com)

[info@globalsew.com](mailto:info@globalsew.com)





**BEFORE  
OPERATING**

## Lubrication

After filling the oil pen, the oil surface should lie between (H) and (L) lines. Add oil, when the oil surface reaches or goes below (L).

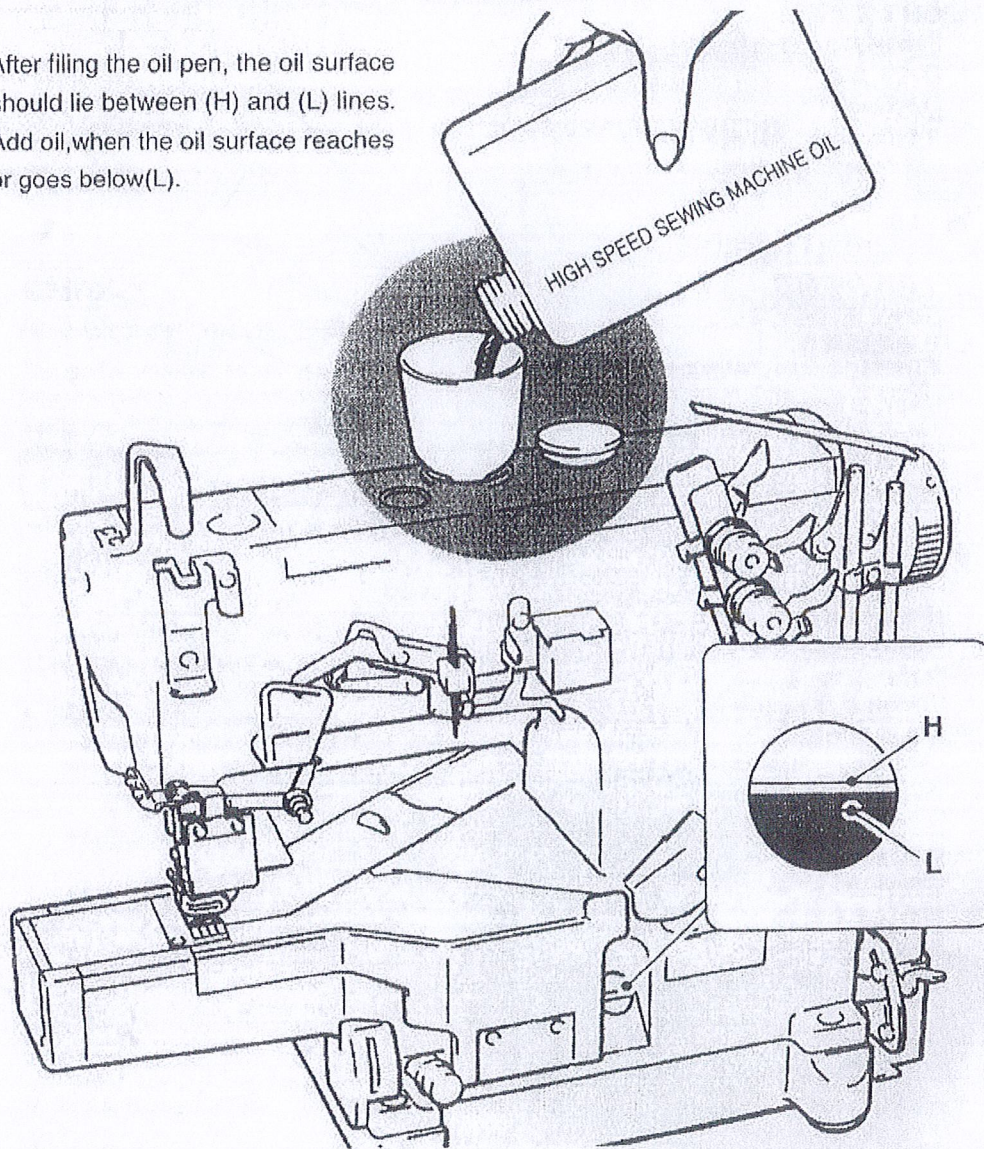



在使用之前  
BEFORE  
OPERATING

## 手动给油 Manual lubrication

手动给油是在缝纫机最初开始使用时，或停用一段时间重新开始使用时，请供给2-3滴油。

Apply 2 or 3 drops of oil by hand when the machine is used for the first time or has been left unused for some time.

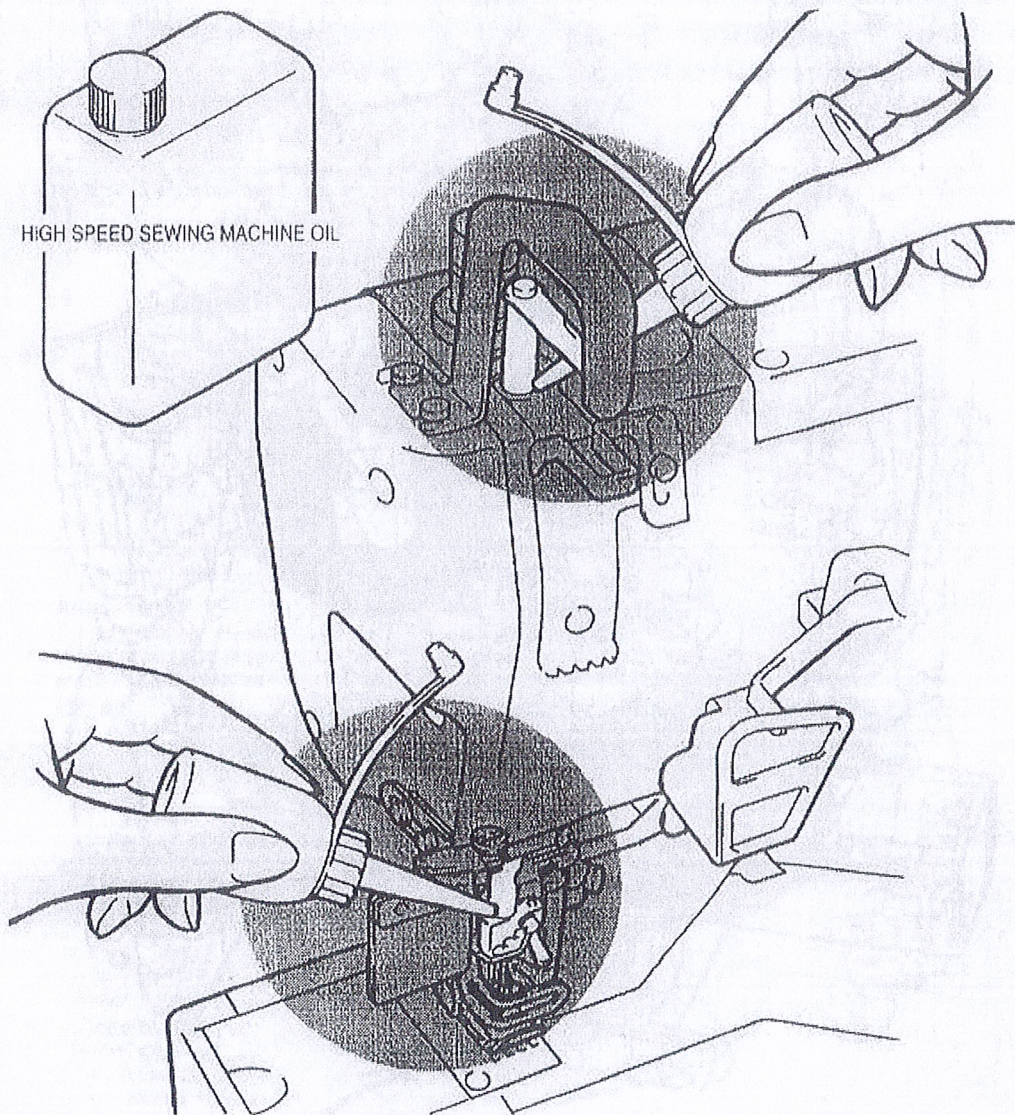



**BEFORE  
OPERATING**

### Filling the HR device with silicon oil

Fill the device with oil before it is too low in order to prevent needle thread breakage and fabric damage

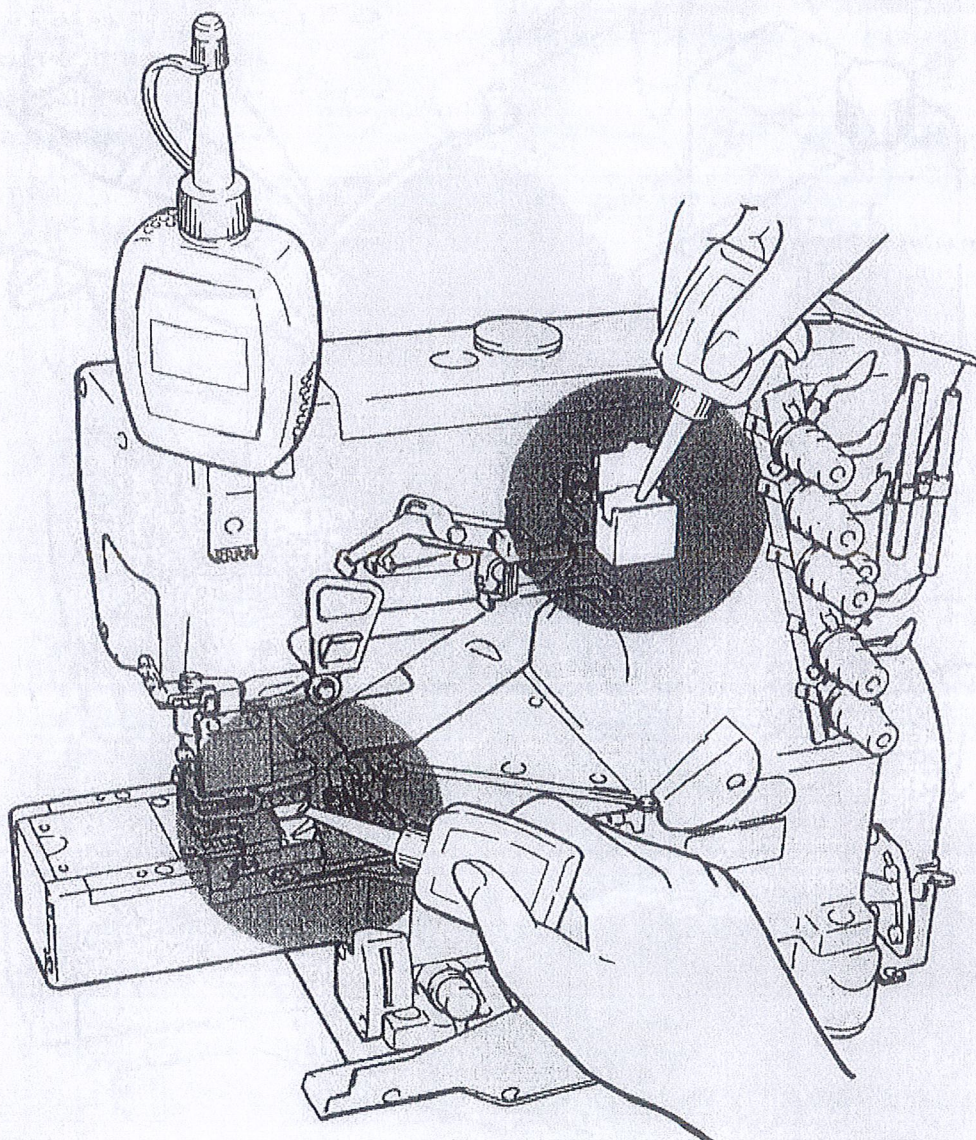



**BEFORE  
OPERATING**

**Lubrication**

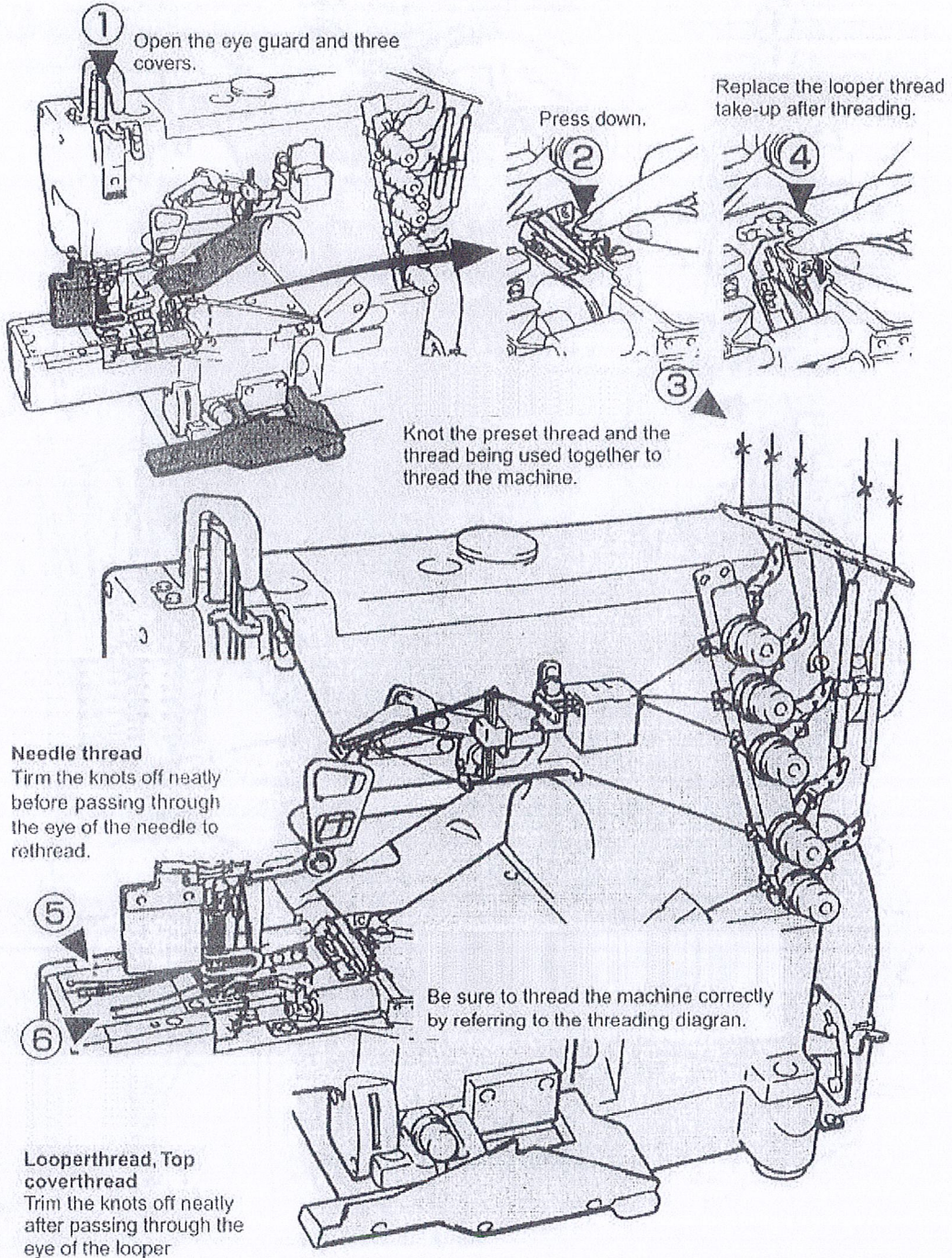



**BEFORE  
OPERATING**

## Threading diagram

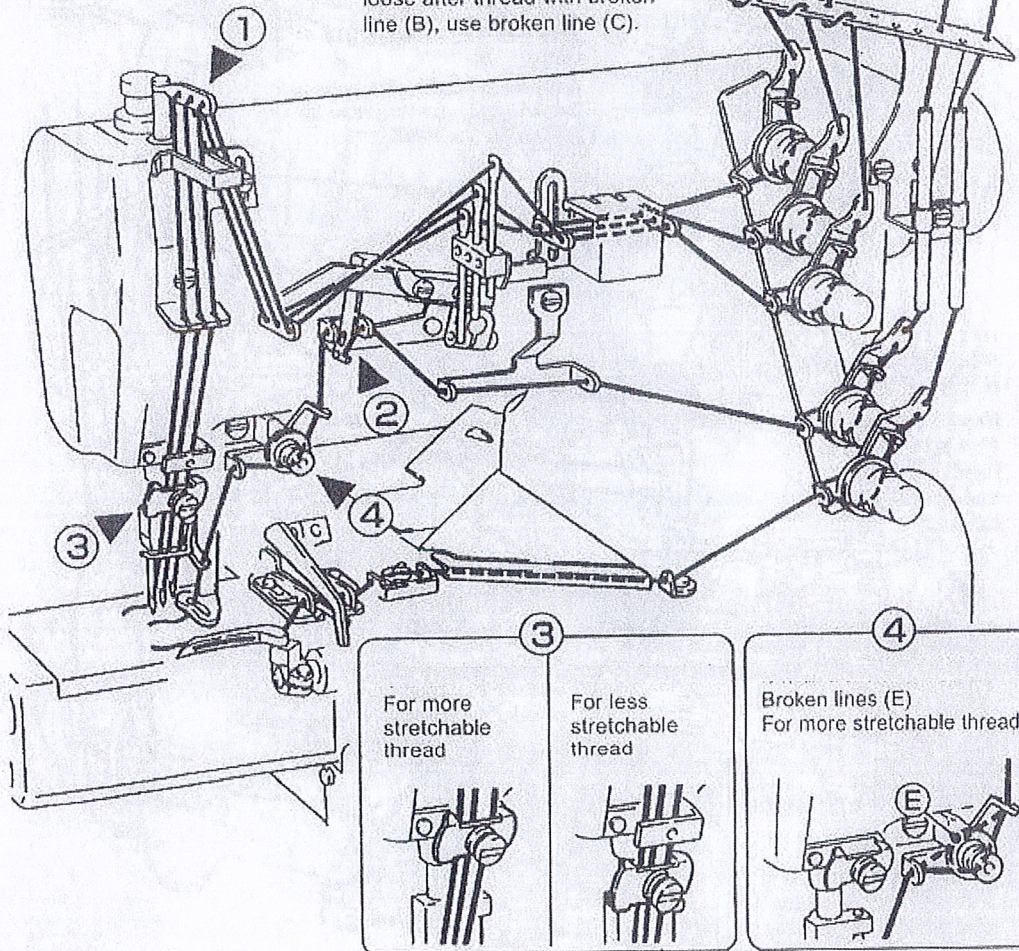
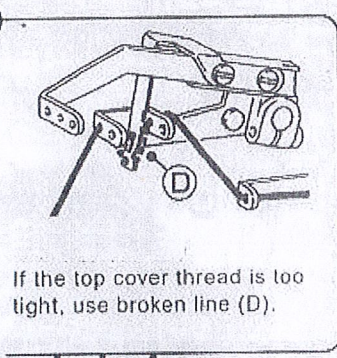
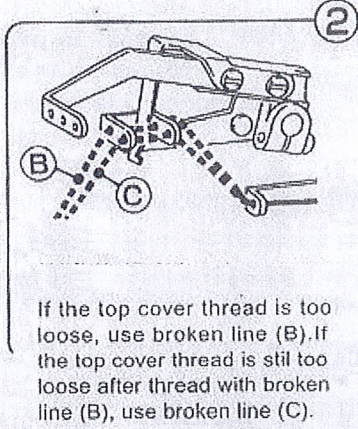
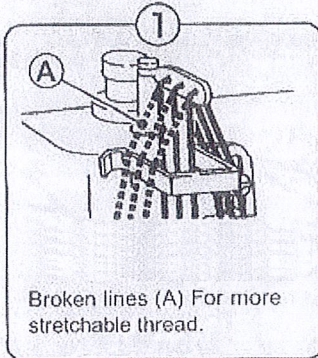



TEST SEWING

## Presser foot pressure

Loosen adjusting (1) nut and turn adjusting screw (2) to adjust the presser foot pressure. It should be as light as possible, yet be sufficient to obtain the proper stitch formation.

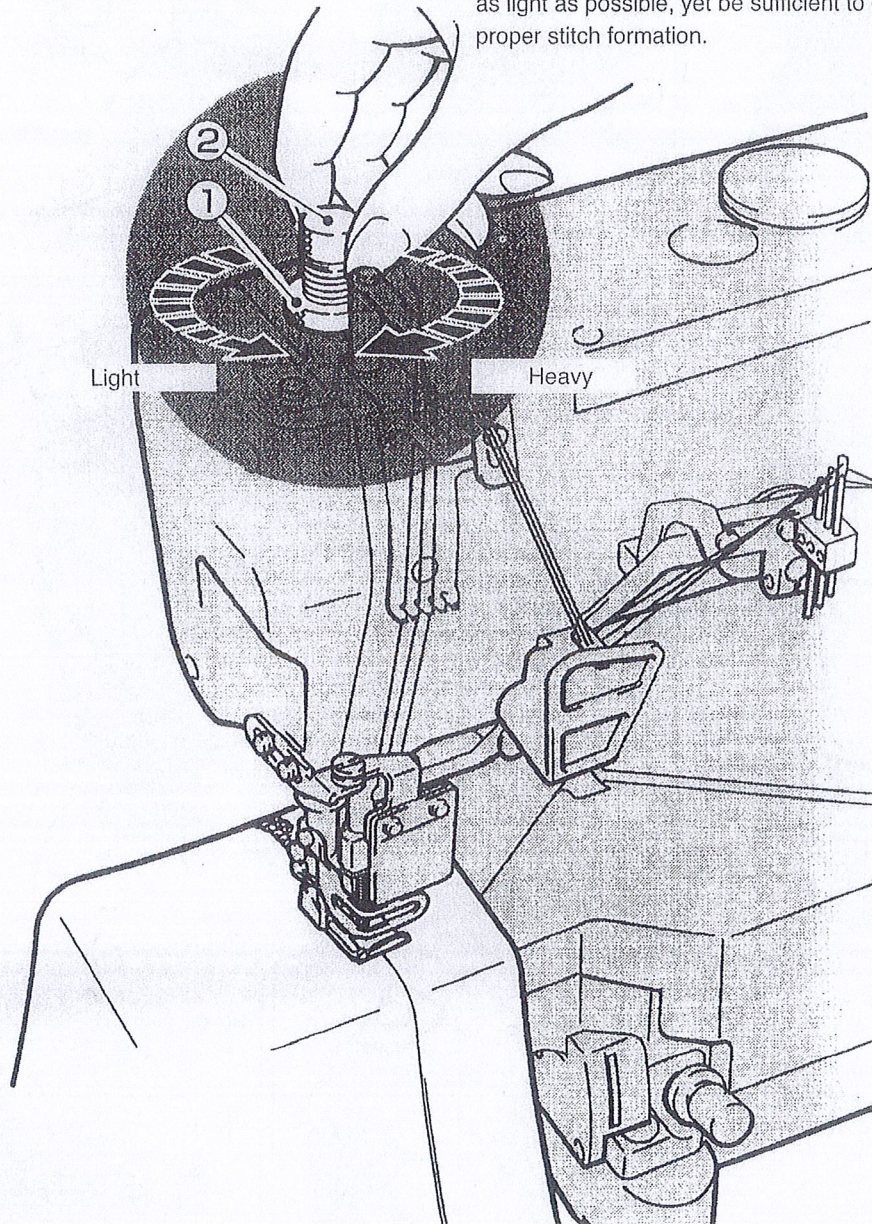



## Diff. feed ratio adjustment

Loosen nut (1) and move the lever up (2) and down to obtain the correct differential feed ratio. then tighten nut (1).

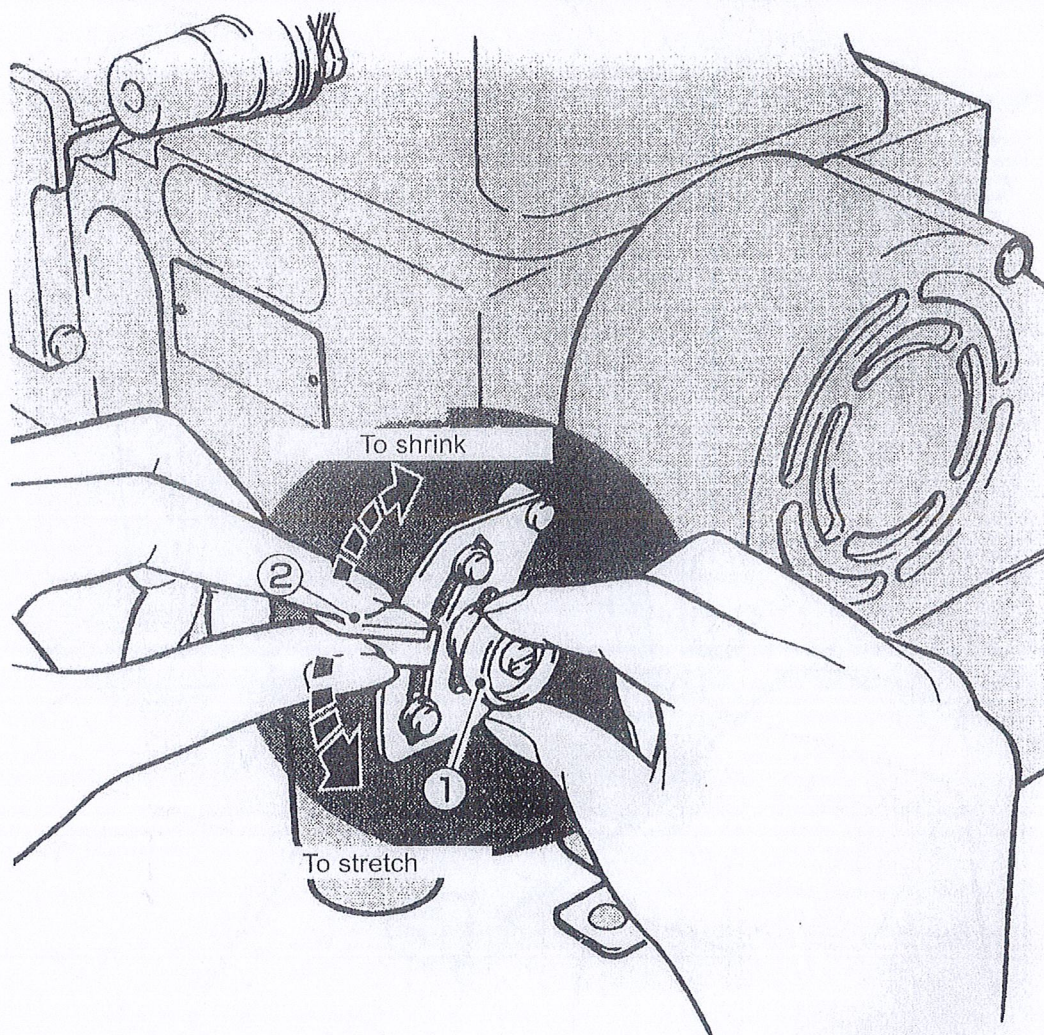



## Stitch length adjustment

Loosen adjusting nut (1) and turn adjusting screw (2) to adjust the stitch length.

Note: Stitch length adjustment must only be made after the differential feed ratio has been changed.

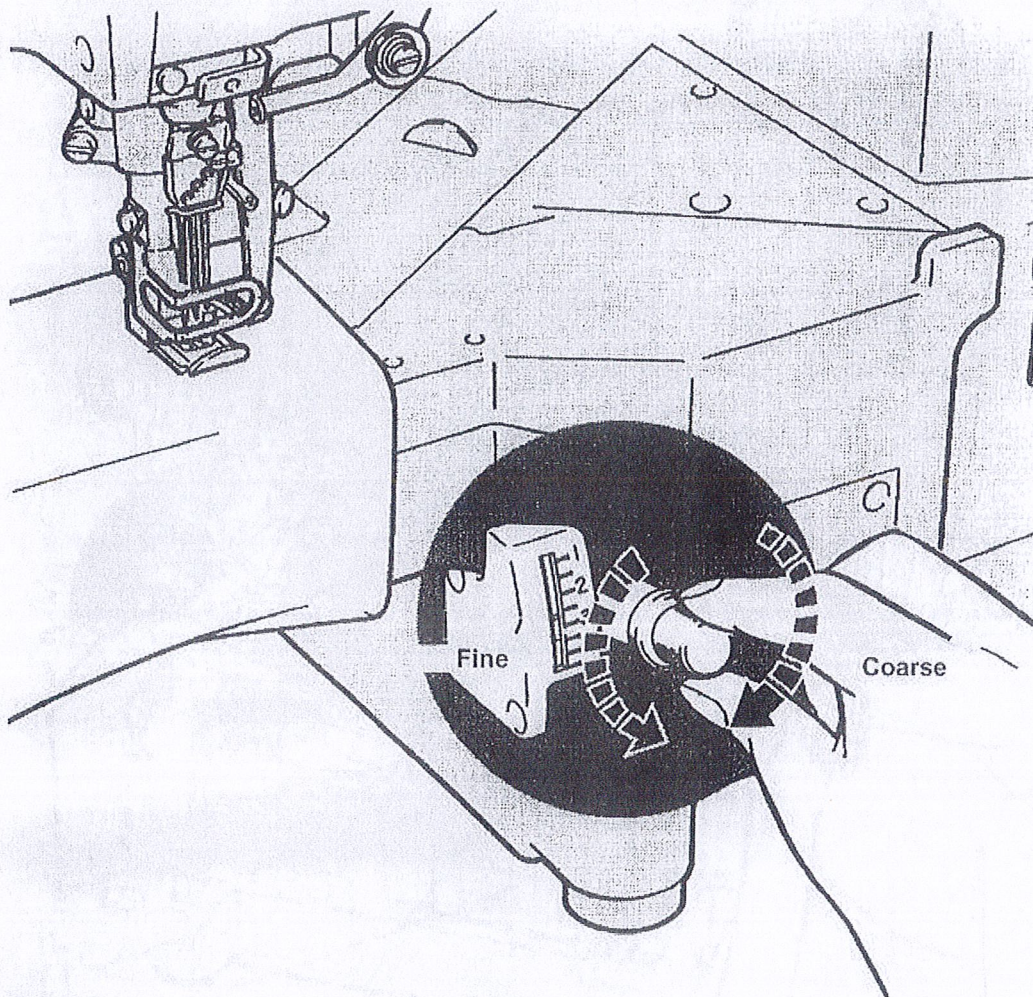



**TEST SEWING**

**Thread tension**

Make tension adjustments with the needle thread knob (1), top cover thread knob (2), and looper thread knob (3).

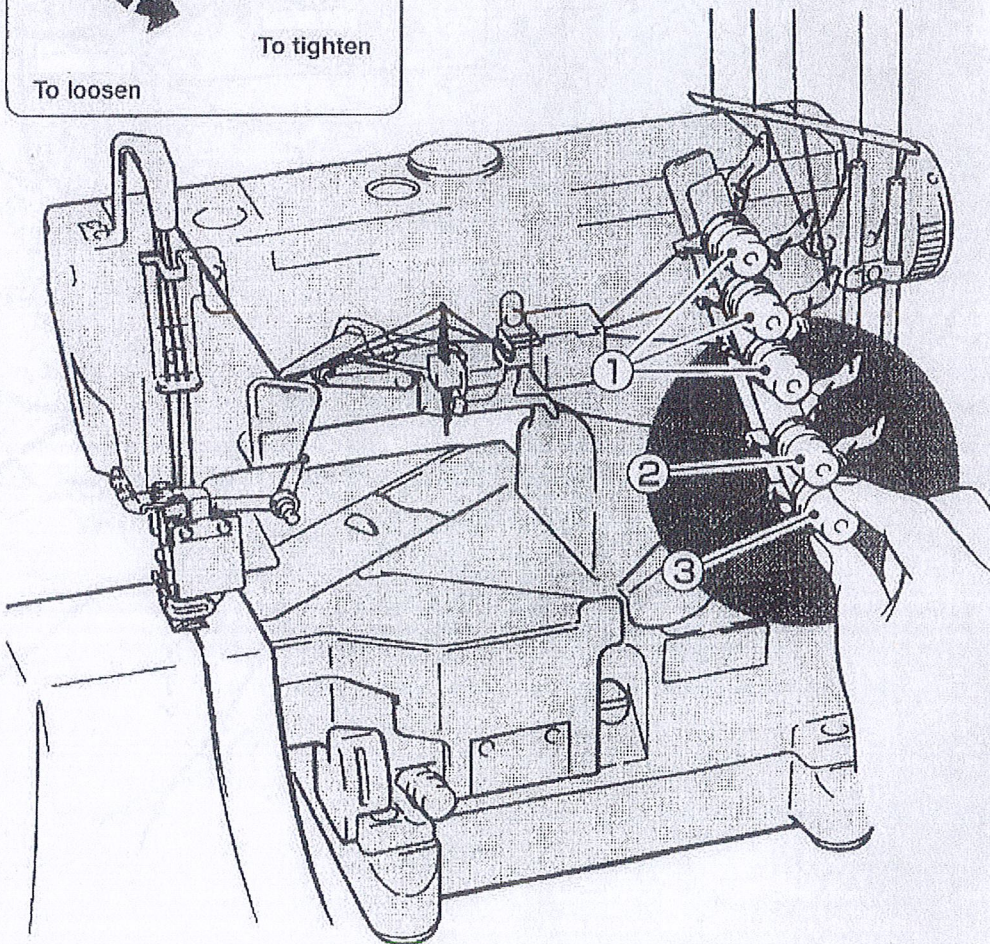
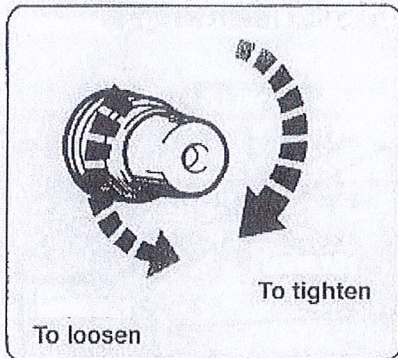



**MAINTENANCE  
DURING USE**

## Cleaning the machine

Mainly the slots of the needle plate and the feed rows should be cleaned.

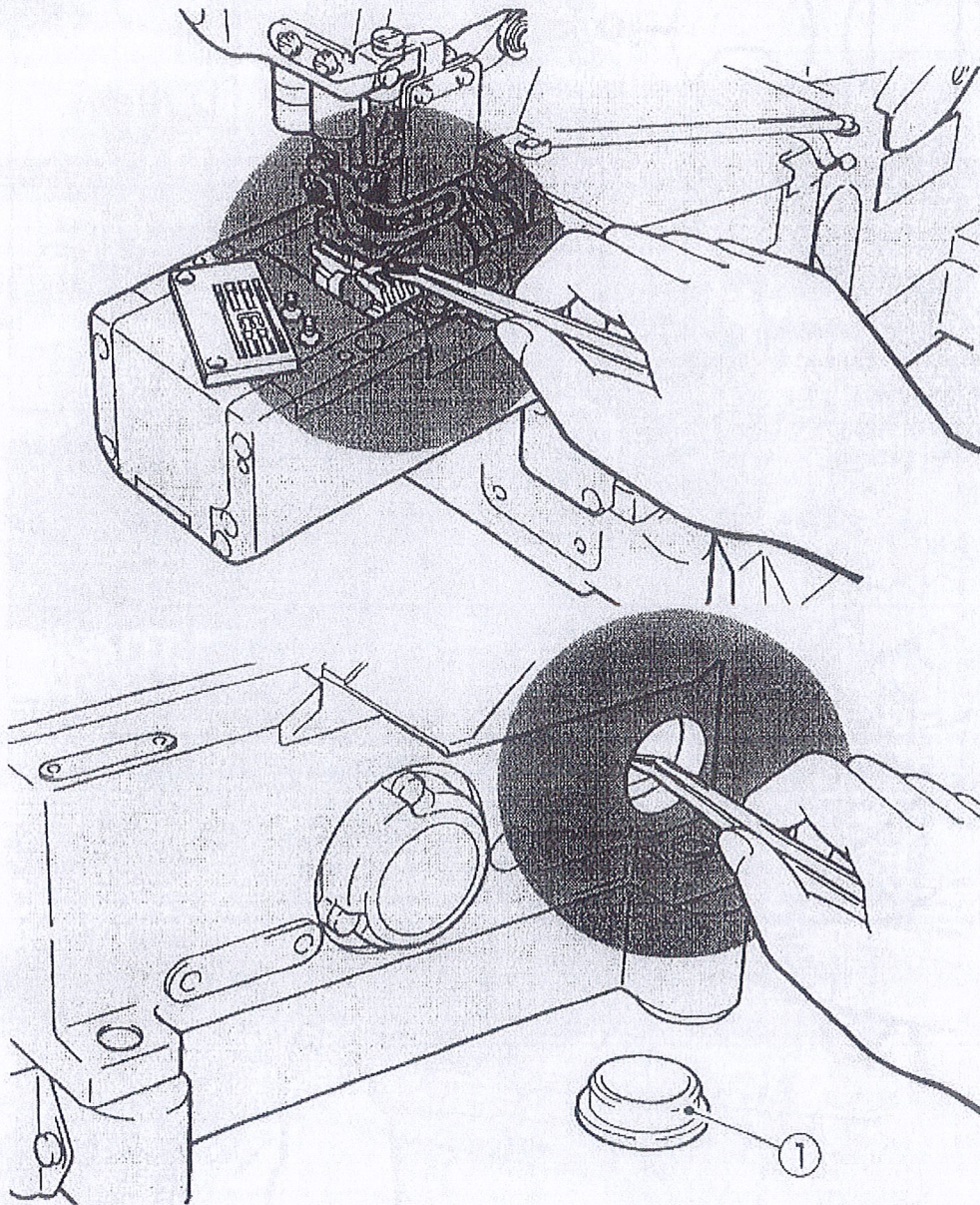



**MAINTENANCE  
DURING USE**

**Replacing the needle**

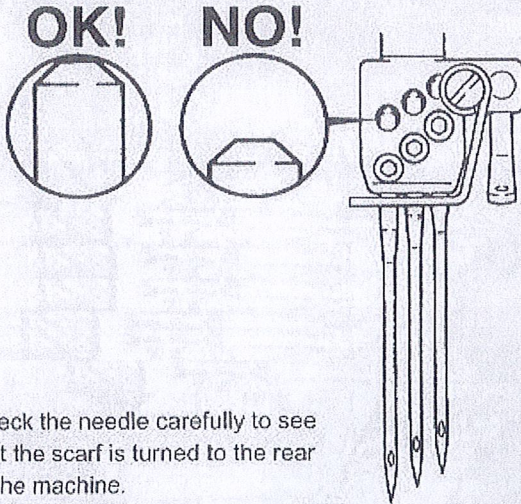

Check the needle carefully to see that the scarf is turned to the rear of the machine. Insert the needle to the proper depth, and fasten securely.

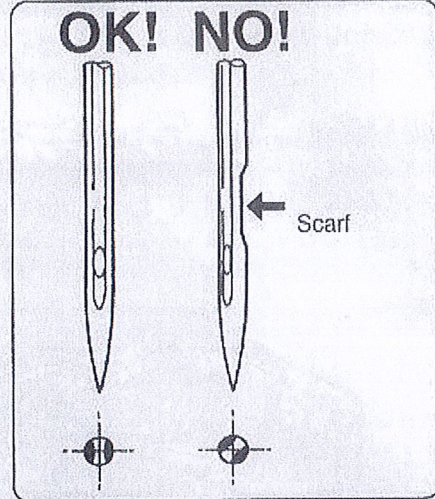

Be sure to use the red-handled allen key wrench packaged in the accessory box.

**[Note]** Do not remove the screw.

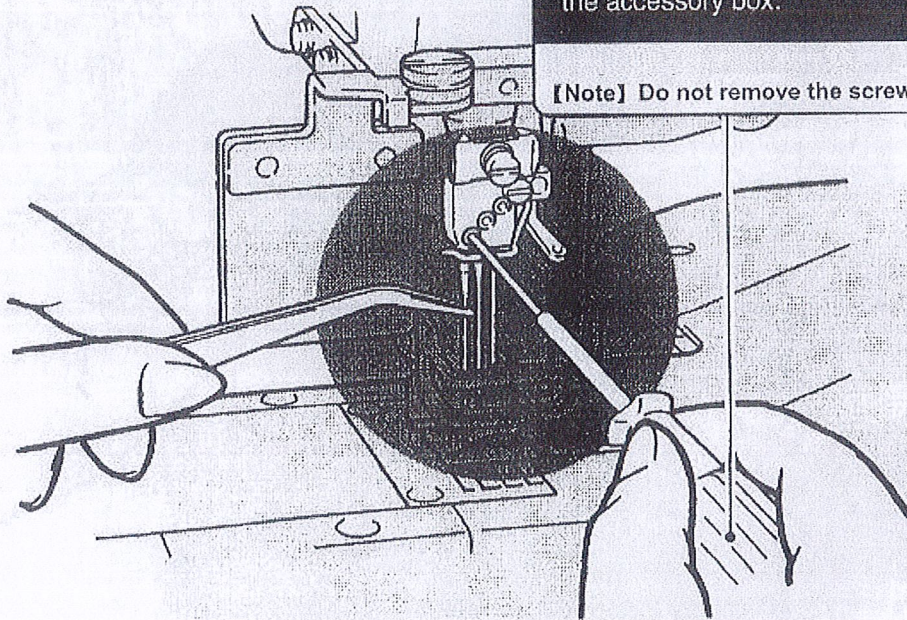



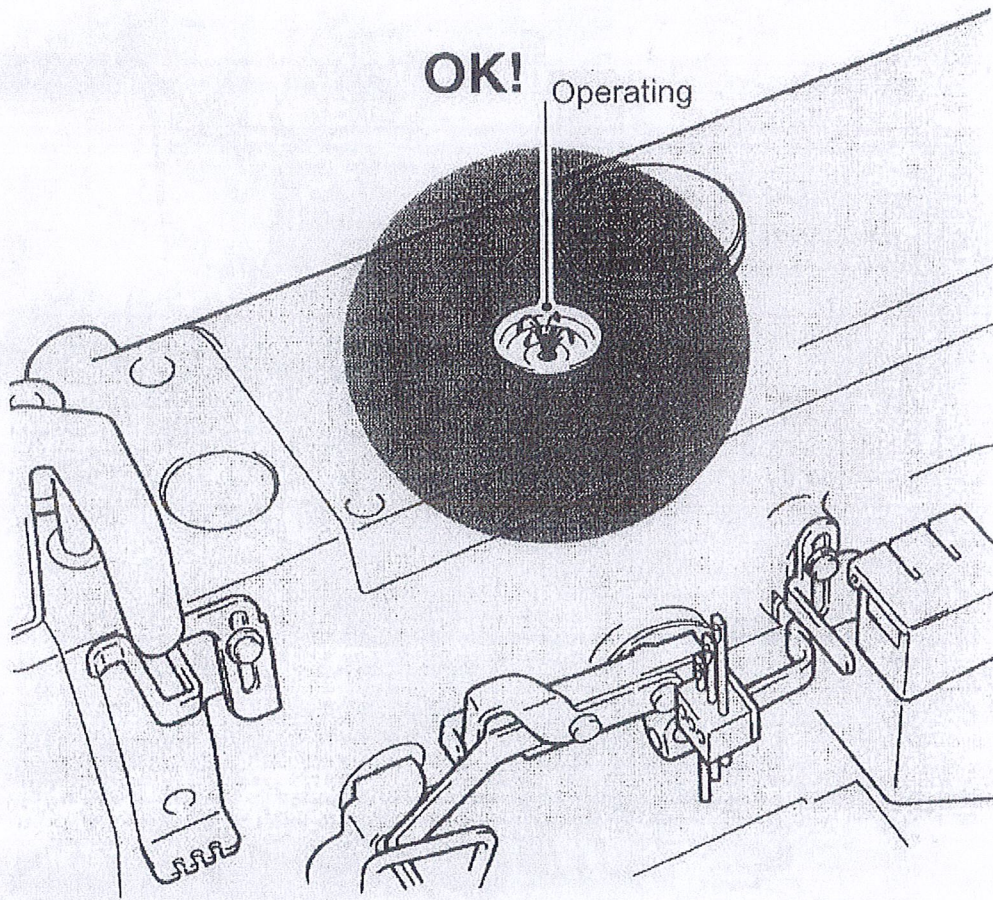



**MAINTENANCE  
DURING USE**

**Checking and replacing the oil filter**

Check and replace the oil filter every six months.

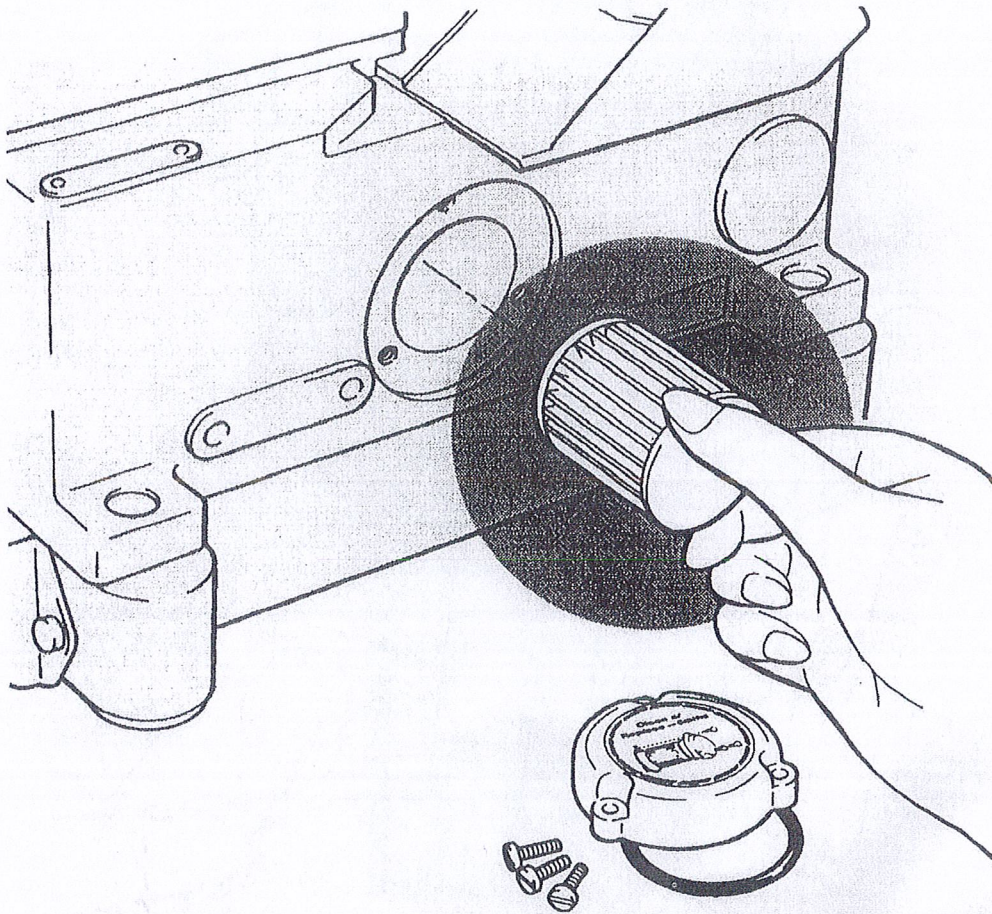

**CHECK AND REPLACE  
EVERY 6 MONTHS!**



**MAINTENANCE  
DURING USE**

## Replacing the oil

Replace the oil one month after the first use and every six months thereafter.

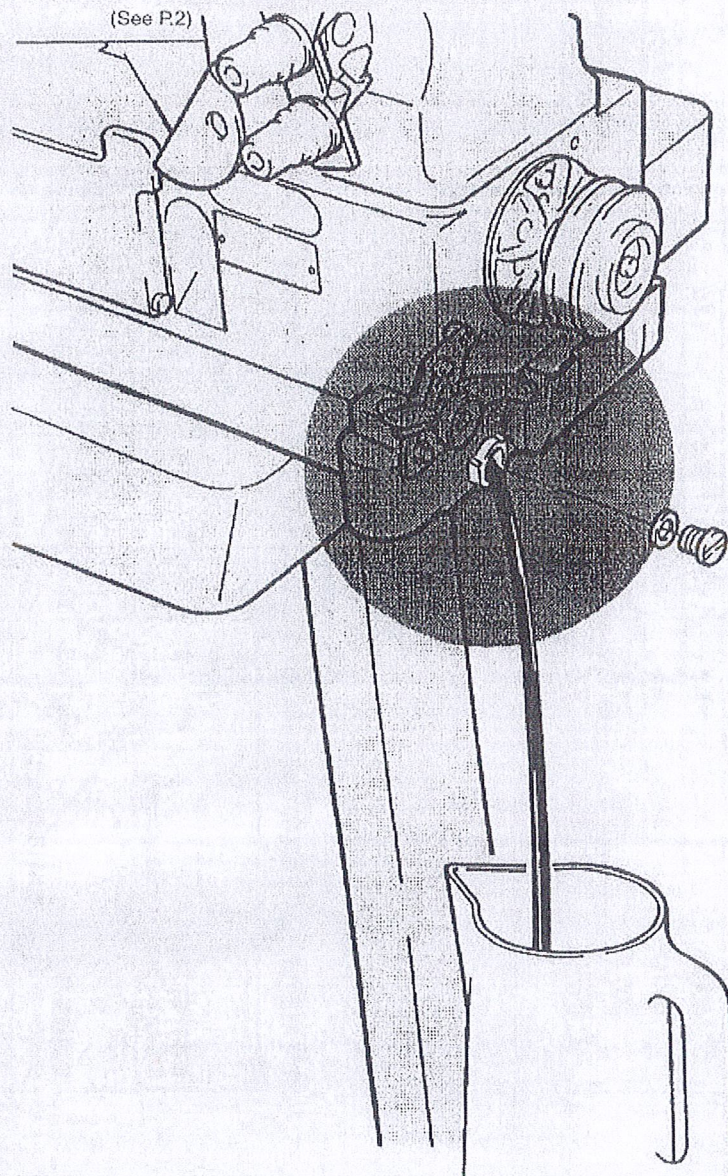



VALORES DE AJUSTE

(mm)







|        |  |  |  |  |  |  |  |  |
|--------|---|---|---|---|--|---|---|--|
| 600-01 | 232   | 8.8   | 4.7~5.0   | 7.5~7.9   | 17.0   | 0.8~1.2   |   |  |
| 600-02 | 240   | 8.3   | 4.3~4.6   | 7.5~7.9   | 17.0   | 0.8~1.2   |   |  |
| 600-03 | 248   | 7.9   | 3.9~4.2   | 7.5~7.9   | 17.0   | 0.8~1.2   |   |  |
| 600-08 | 256   | 7.5   | 3.5~3.8   | 7.5~7.9   | 17.0   | 0.8~1.2   |   |  |
|        | 264   | 7.1   | 3.1~3.4   | 7.5~7.9   | 17.0   | 0.8~1.2   |   |  |
|        | 356   | 7.5   | 3.5~3.8   | 7.5~7.9   | 17.0   | 0.8~1.2   |   |  |
|        | 364   | 7.1   | 3.1~3.4   | 7.5~7.9   | 17.0   | 0.8~1.2   |   |  |

Tabla de comparación de grosores de aguja epuivalentes

|  | #  | 9  | 10 | 11 | 14 | 16  | 18  | 21  |
|--|----|----|----|----|----|-----|-----|-----|
| (Organ)<br>Grosor de aguja japonés(Organ)      |    |    |    |    |    |     |     |     |
| (Schmetz)<br>Grosor de aguja metrico (Schmetz) | Nm | 65 | 70 | 75 | 90 | 100 | 110 | 130 |

Aguja estándar

|        | X□□□□ | DCx27 |
|--------|-------|-------|
| 600-01 | 232   | 9S    |
| 600-02 | 240   | 9S    |
| 600-03 | 248   | 9S    |
| 600-08 | 256   | 9S    |
|        | 356   | 10S   |
|        | 364   | 10S   |



1

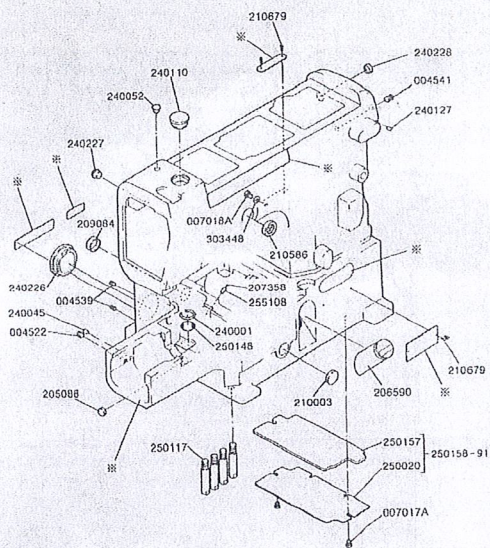

2

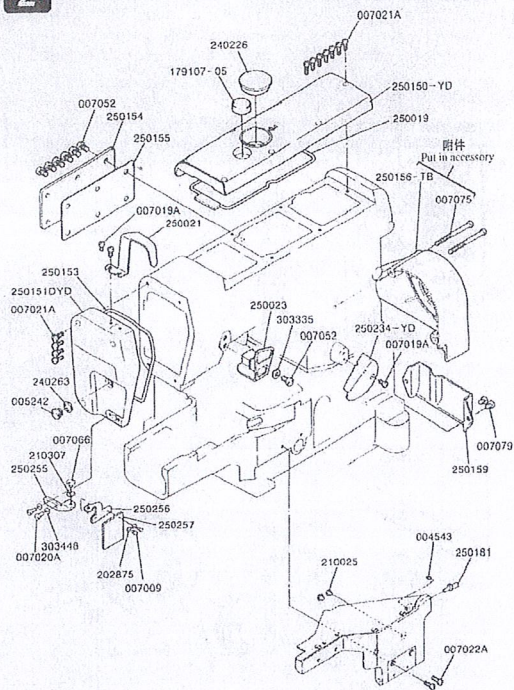

3

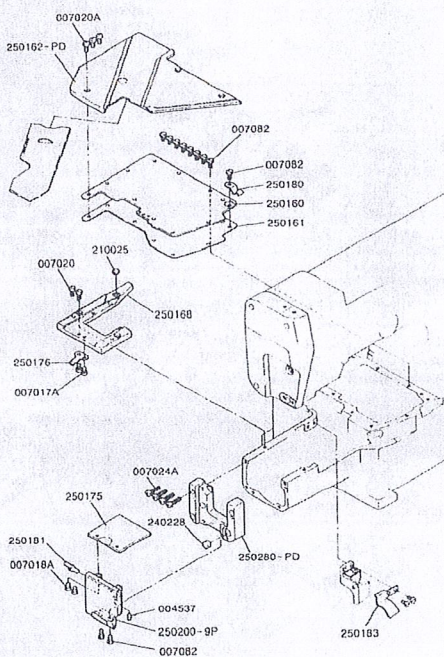

4

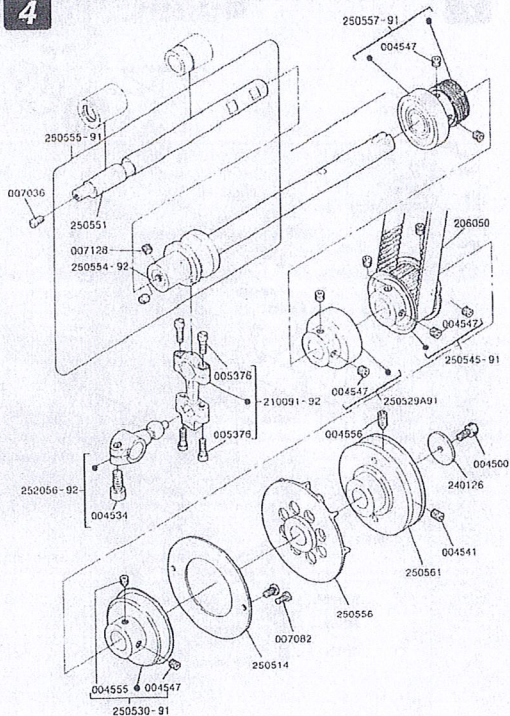



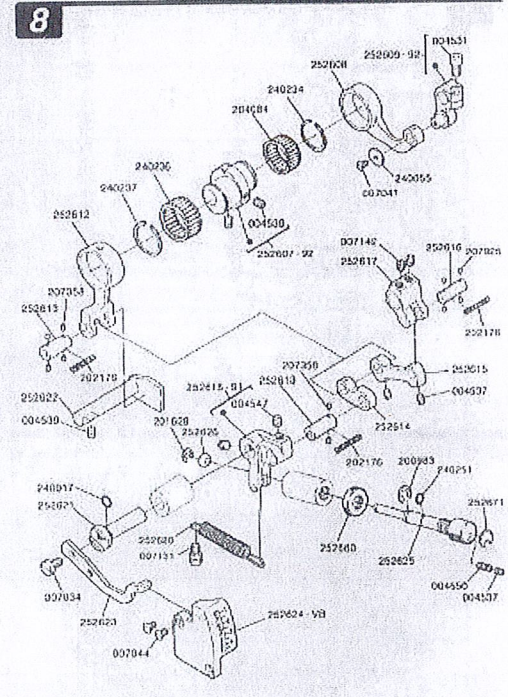
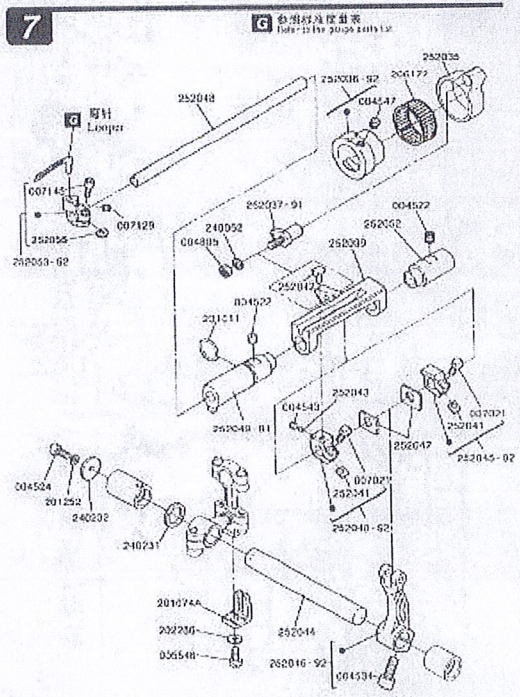
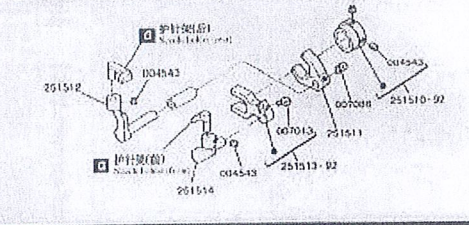
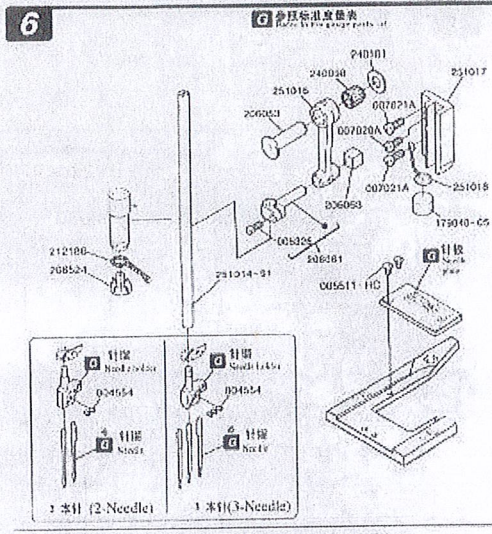
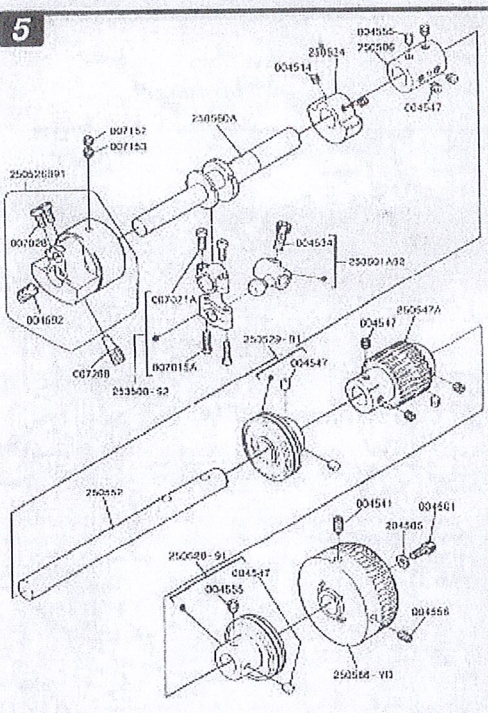



9

参照标准度量表  
Refer to the gauge parts list.

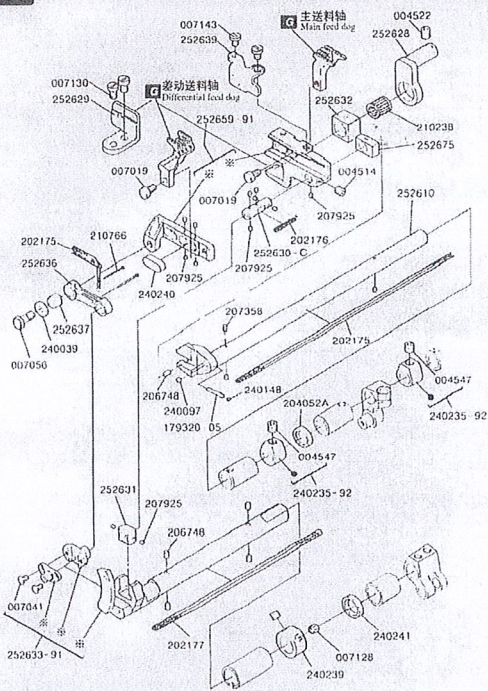

10

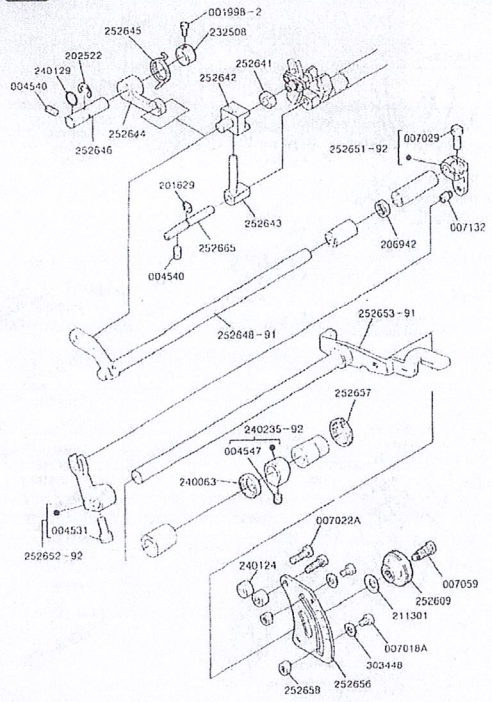

11

参照标准度量表  
Refer to the gauge parts list.

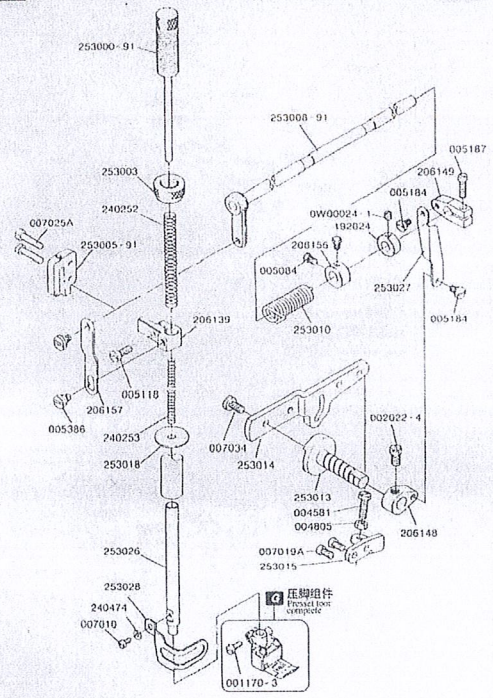

12

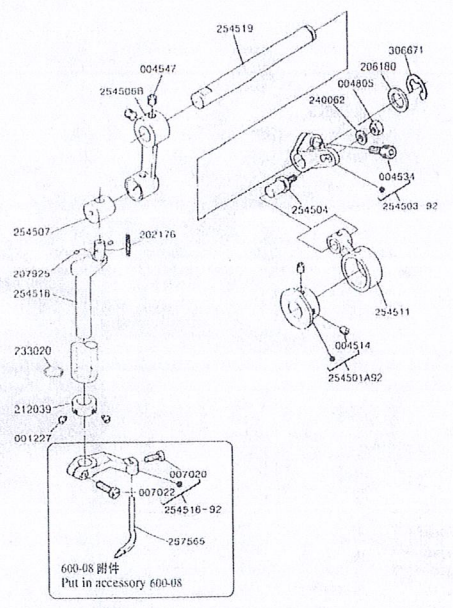

600-08 附件  
Put in accessory 600-08



13

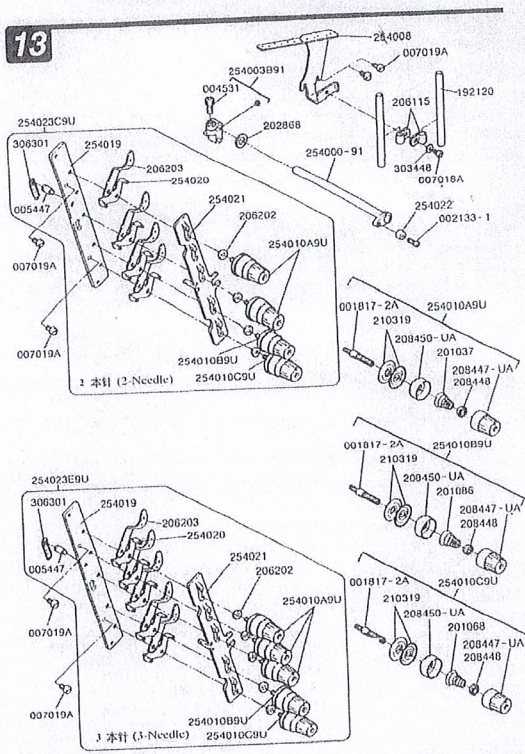

14

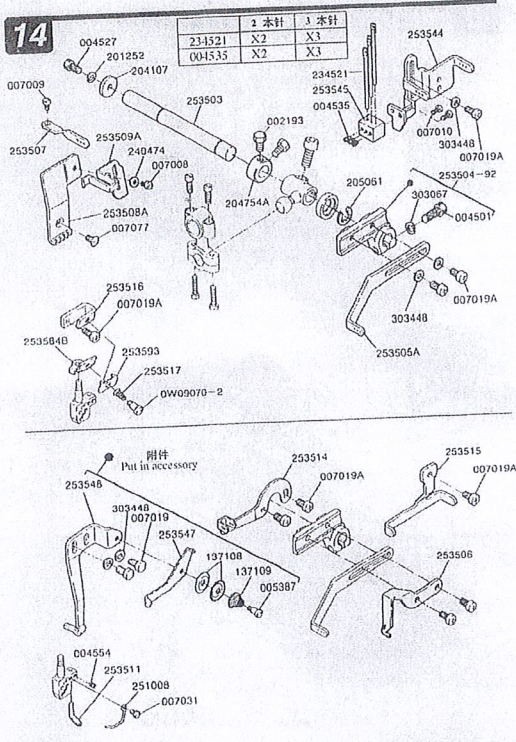

15

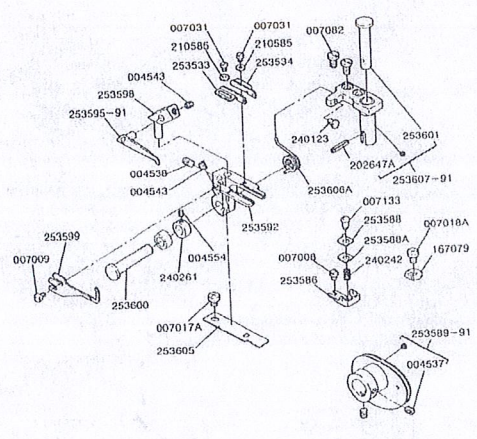

16

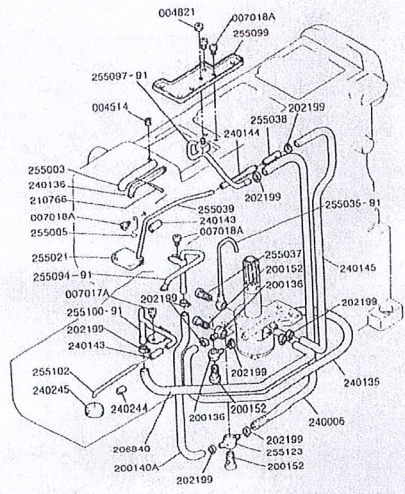



17

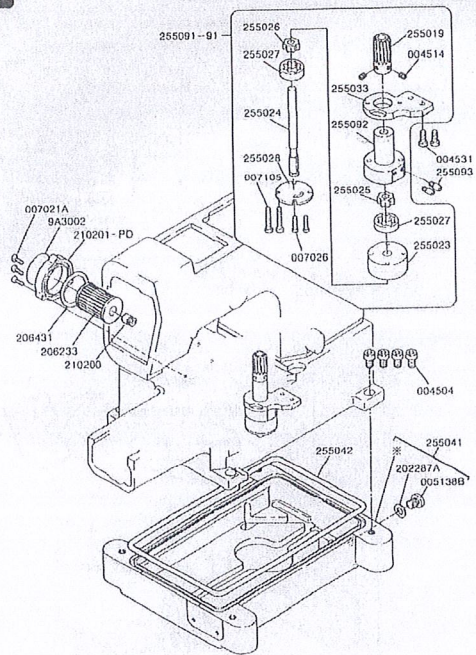

18

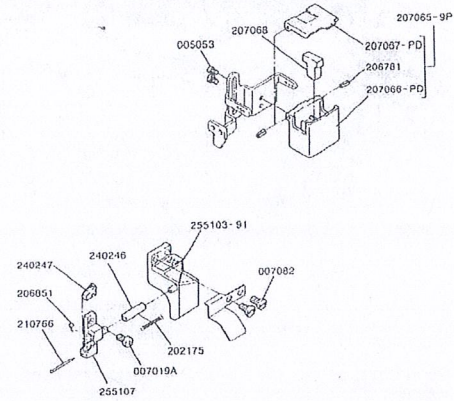

19

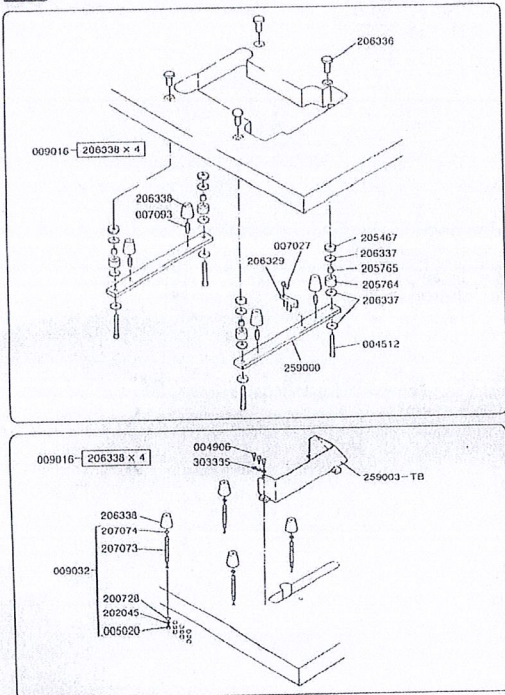

20

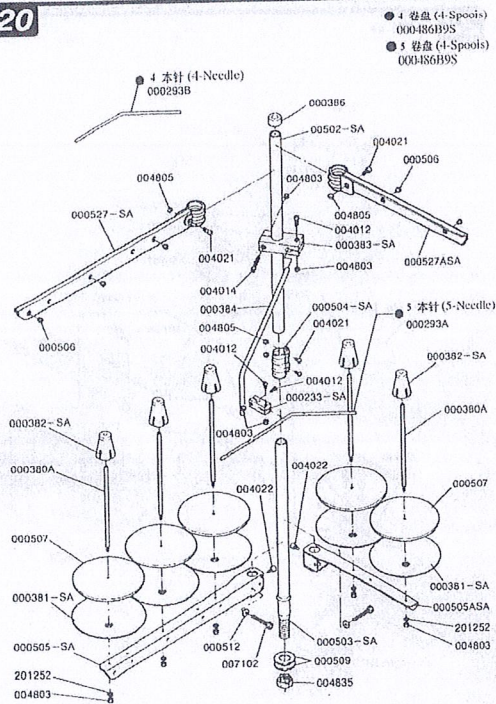



21

600-01

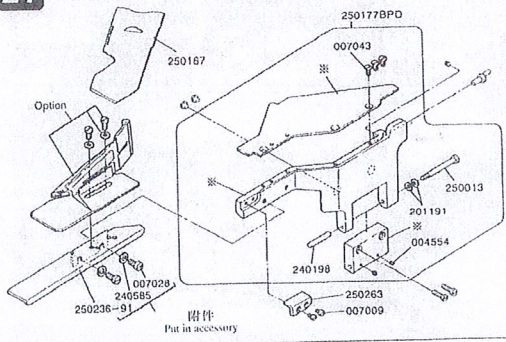

600-03

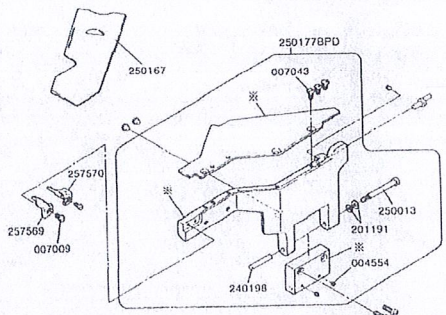

22

600-02

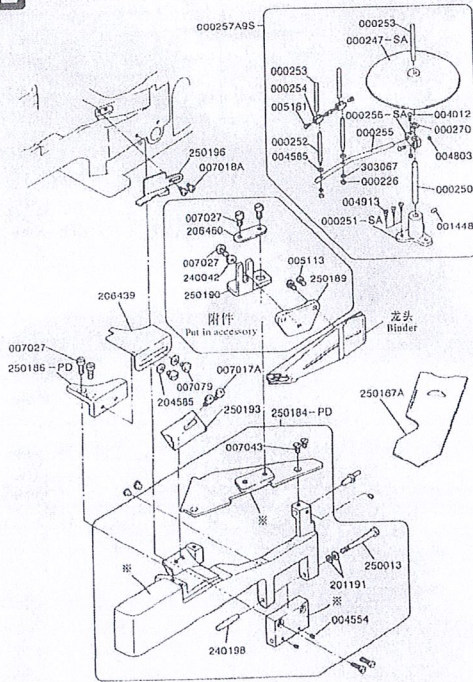

23

600-08

