

GLOBAL

BH 783 DD Buttonhole machine

Instruction manual

Always switch off the electricity when working on
the machine.

零件册

PARTS BOOK

目次

1. 机壳部件
2. 安全板部件
3. 上轴部件
4. 下轴部件
5. 压棒及送料部件
6. 针杆架部件
7. 针摆幅度调节部件
8. 剪面线器部件
9. 剪底线器部件
10. 刀杆部件
11. 送布凸轮及离合器部件
12. 止动部件
13. 运转脱离部件
14. 压脚提升架和绕线器部件
15. 夹线器部件
16. 润滑机构部件
17. 电器控制部件

CONTENTS

- FRAME & MISCELLANEOUS COVER COMPONENTS (1)
- FRAME & MISCELLANEOUS COVER COMPONENTS (2)
- MAIN SHAFT COMPONENTS
- HOOK DRIVING SHAFT COMPONENTS
- PRESSER BAR WORK CLAMP CARRIER COMPONENTS
- NEEDLE BAR FRAME COMPONENTS
- OVEREDGING WIDTH ADJUSTING COMPONENTS
- NEEDLE THREAD TRIMMER COMPONENTS
- BOBBIN THREAD TRIMMER COMPONENTS
- KNIFE BAR COMPONENTS
- FEED CAM & TRIPPING SEGMENT COMPONENTS
- STOP-MOTION COMPONENTS
- TRIPPING LEVER COMPONENTS
- LIFTING LEVER & BOBBIN WINDER COMPONENTS
- THREAD TENSION COMPONENTS
- LUBRICATION MECHANISM COMPONENTS
- ELECTRICAL CONTROL COMPONENTS

1. 机壳部件 FRAME & MISCELLANEOUS COVER COMPONENTS

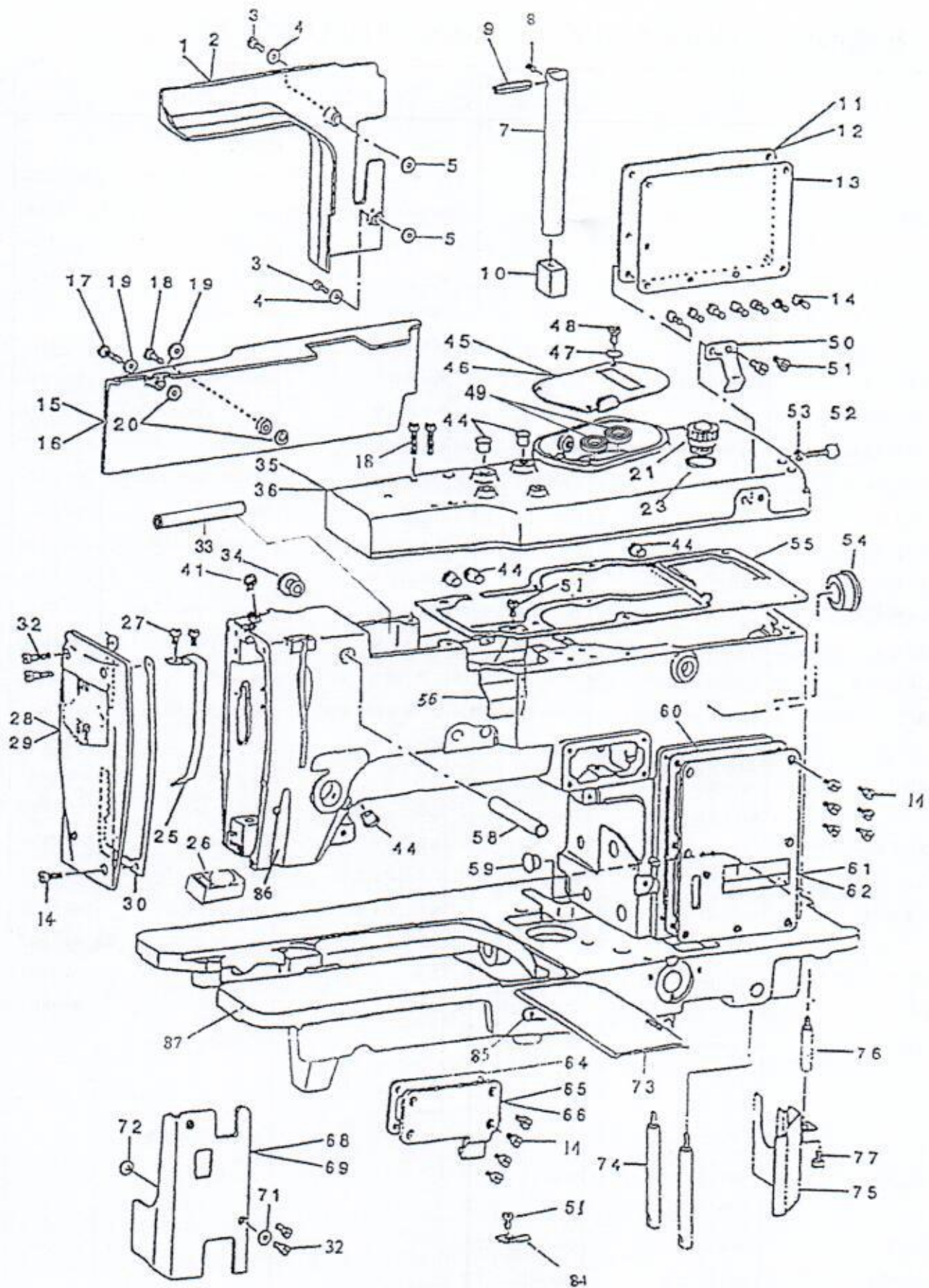

1. 机壳部件

FRAME & MISCELLANEOUS COVER COMPONENTS (1)

序号	零件名称	Description	制造件号 (标准件规格)	数量	序号	零件名称	Description	制造件号 (标准件规格)	数量
1	左侧下侧盖	FRAME SIDE COVER B	780-10106	1	47	弹簧垫6	DISK SPRING	GB/T960-1986	1
3	螺钉11/64-40, L=12	SCREW 11/64-40 L=12	780-10107	2	48	箱盖螺钉D=3.65, H=2.6	HINGE SCREW D=3.65 H=2.6	780-10137	1
4	垫圈4.5×8×0.5	WASHER 4.5×8×0.5	780-10108	2	49	旋转轴球形密封圈 EB022035	RUBBER RING $\phi 2 \times \phi 35 \times 7$	GB/T13871-1992	2
5	缓冲垫圈	CUSHION	780-10109	2	50	手柄限位簧	HAND STOP LATCH	780-10139	1
7	机头支承臂	MACHINE ARM SUPPORT ROD	780-10110	1	51	螺钉11/64-40, L=7	SCREW 11/64-40 L=7	780-10140	4
8	螺钉11/64-40, L=5	SCREW 11/64-40 L=5	780-10111	1	52	球形锁紧螺钉	BALL SCREW	780-10141	1
9	弹性圆柱销6×30	PIN	GBS79-76	1	53	螺母3/16-28	NUT 3/16-28	780-10142	1
10	橡胶缓冲垫	RUBBER CUSHION	780-10112	1	54	橡胶插塞	RUBBER PLUG	780-10143	1
11	左侧后侧盖	SIDE COVER (C)	780-10113	1	55	顶盖后衬垫	TOP COVER GASKET REAR	780A-10144	1
13	左侧后侧盖衬垫	SIDE COVER GASKET (C)	780-10114	1	56	偏心凸轮挡油罩	ARM OIL SHIELD	780-10145	1
14	螺钉11/64-40, L=9	SCREW 11/64-40 L=9	780-10115	20	58	停刀杆轴轴套	KNIFE STOP LEVER SHAFT GUIDE	780-10146	1
15	左侧上侧盖	FRAME SIDE COVER C	780A-10116	1	59	橡胶插塞	RUBBER PLUG	780-10147	1
17	螺钉11/64-40, L=22	SCREW 11/64-40 L=22	780-10117	1	60	右侧后侧盖衬垫	SIDE COVER (A) GASKET	780-10148	1
18	螺钉11/64-40, L=18	SCREW 11/64-40 L=18	780-10118	7	61	右侧后侧盖	SIDE COVER (A)	780-10149	1
19	缓冲垫圈	CUSHION	780-10109	2	64	油窗盖衬垫	OIL SIGHT WINDOW GASKET	780-10150	1
20	缓冲垫圈	FRAME SIDE COVER GASKET (C)	780-10119	2	65	右侧上侧盖	SIDE COVER B	780A-10151	1
21	示油镜M26×1.5	OIL SIGHT WINDOW		1	68	右侧下侧盖	SIDE COVER A	780-10152	1
23	O形橡胶密封圈 $\phi 23.6$	OIL SIGHT WINDOW GASKET	GB/T3452.1-1992	1	71	垫圈4.5×8×0.5	WASHER 4.5×8×0.5	780-10108	2
					72	缓冲垫圈	CUSHION	780-10109	2
25	挑线杆护罩	THREAD TAKE-UP LEVER OIL GUARD	780-10122	1	73	推板	BED SLIDE	780-10153	1
26	挡油器	BLOCK OIL PLANK	780A-10126	1	74	底板支承螺钉	BED SCREW STD A	780A-10155	2
27	螺钉9/64-40, L=5	SCREW 9/64-40 L=5	780-10123	2	75	底板挡油罩	BED OIL SHIELD	780-10156	1
28	面板	FACE COVER COMPLETE	780A-10124	1	76	底板挡油罩螺钉	LOWER COVER OIL SHIELD STUD	780-10157	1
30	面盖板衬垫	FACE PLATE GASKET	780A-10125	1	77	螺钉11/64-40, L=5	SCREW 11/64-40 L=5	780-10158	1
					84	推簧板	BED SLIDE SPRING	780-10154	1
32	螺钉11/64-40, L=14	SCREW 11/64-40 L=14	780-10127	4	86	机头	MACHINE HEAD	780-10101	1
33	钢管		780A-10128	4	87	底板	SCALEBOARD	780-10102	1
35	顶盖	TOP COVER	780A-10129	1					
41	橡胶塞	RUBBER PLUG	780A-10133	1					
44	橡胶塞	RUBBER PLUG	780-10135	7					
45	齿轮箱盖	GEAR CASE COVER	780-10136	1					

2. 安全板部件 PRAME & MISCELLANEOUS COVER COMPONENTS (2)

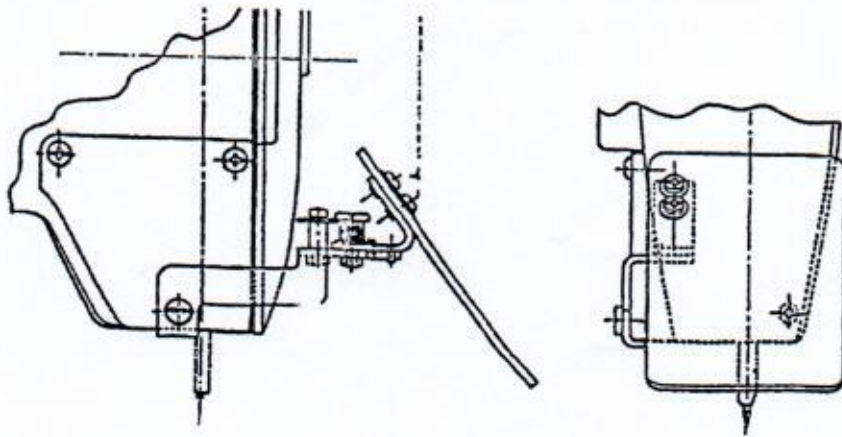
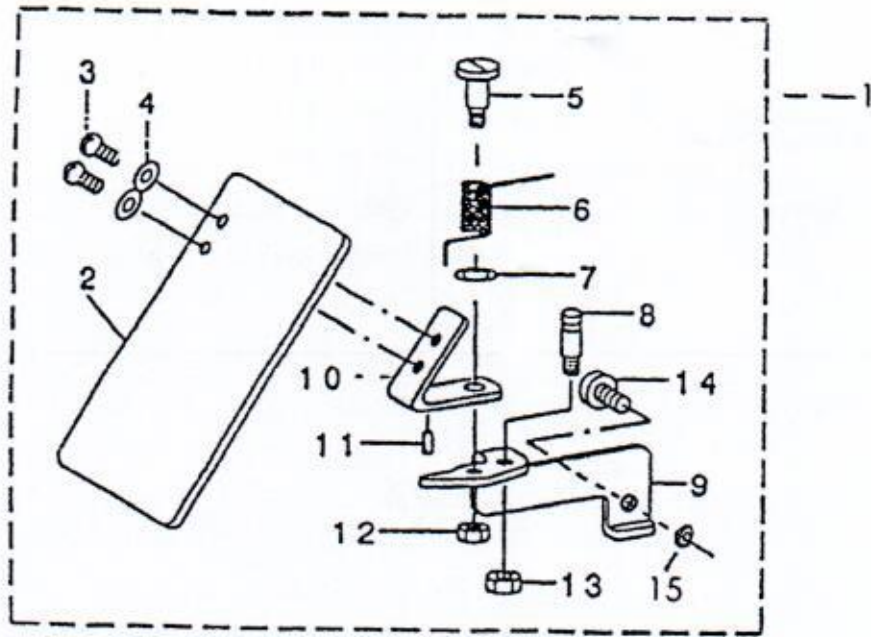

2. 安全板部件 FRAME & MISCELLANEOUS COVER COMPONENTS

序号	零件名称	Description	制造件号 (标准件规格)	数量	序号	零件名称	Description	制造件号 (标准件规格)	数量
1	安全板组件	SAFETY PLATE ASM	780-10201	1	8	螺柱	TENSION SPRING RACK B	780-10208	1
2	安全板	SAFETY PLATE	780-10202	1	9	安全板连接架座	SAFETY PLATE INSTALLING BASE	780-10209	1
3	螺钉11/64-40, L=7	SCREW 11/64-40 L=7	780-10203	2	10	安全板连接架	SAFETY PLATE INSTALLING PLATE	780-10210	1
4	垫圈4.5×10×0.8	WASHER 4.5×10×0.8	780-10204	2	11	弹性圆柱销2×6	SPRING PIN 2×6	GB879-76	1
5	连接架座连接螺钉	HINGE SCREW	780-10205	1	12	螺母11/64-40	NUT 11/64-40	780-10211	1
6	扭矩弹簧	SAFETY PLATE RETURN SPRING	780-10206	1	13	螺母3/16-28	NUT 3/16-28	780-10142	1
7	垫圈7.4×11.8×0.5	WASHER 7.4×11.8×0.5	780-10207	1	14	螺钉11/64-40, L=8	SCREW 11/64-40 L=8	780A-10529	1
					15	垫圈6.5×11×1	WASHER 6.5×11×1	780A-11432	1

3. 上轴部件 MAIN SHAFT COMPONENTS

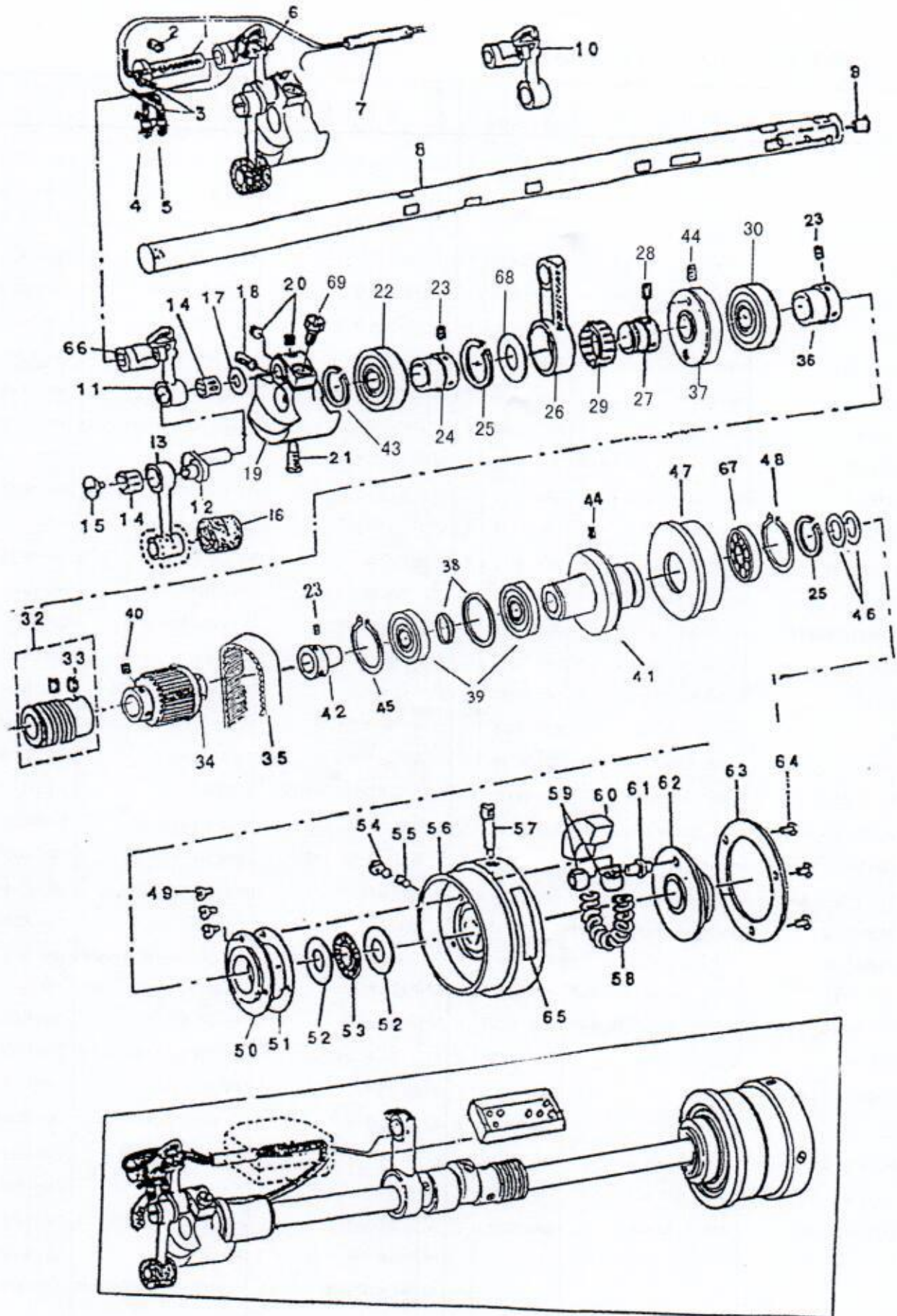

3. 上轴部件 MAIN SHAFT COMPONENTS

序号	零件名称	Description	制造件号 (标准件规格)	数量	序号	零件名称	Description	制造件号 (标准件规格)	数量
1	挑线连杆销	HINGE STUD	780-10301	1	34	上轴同步带轮	UPPER SHAFT SPROCKET	780A-10332	1
2	螺钉15/64-28, L=10.5	SCREW 15/64-28 L=10.5	780-10302	1	35	同步带	TIMING BELT	780A-10336	1
3	油芯	OIL WICK	780-10303	1	36	上轴中轴承定位套	BUSHING CENTER POSITION SET	780A-10334	1
4	油芯	OIL WICK	780A-10304	1	37	上轴中轴承套	BUSHING CENTER SET	780A-10333	1
5	油芯	OIL WICK	780A-10305	1	38	后轴承隔圈	BUSHING BEHIND RING	780A-10335	2
6	油芯环	OIL WICK SNAP RING	780-10306	1	39	上轴后轴承	BUSHING BEHIND	61904-Z	2
7	套管(白色)	VINYL PIPE	780-10307	1	40	螺钉 M6×7	SCREW M6×7	GB/T77-2000	2
8	上轴	MAIN SHAFT	780A-10308	1	41	上轴后轴承座	BUSHING BEHIND BASE	780A-10337	1
9	橡胶堵塞	RUBBER PLUG	780-10309	1	42	后轴承定位套	BUSHING BEHIND POSITION SET	780A-10338	1
10	挑线杆组件	THREAD TAKE-UP LEVER ASM CER	780-10310	1	43	轴用挡圈φ20	RETAINING RING 20	GB/T894.1-1986	1
11	挑线杆组件	THREAD TAKE-UP LEVER ASM	780-10312	1	44	螺钉15/64-28, L=7	SCREW 15/64-28 L=7	780-10323	2
12	针杆曲柄	NEEDLE BAR CRANK	780-10313	1	45	孔用挡圈φ37	RETAINING RING 37	GB/T893.1-1986	1
13	针杆曲柄连杆	NEEDLE BAR CRANK CONNECTING ROD	780-10314	1	46	调整垫圈	WASHER B	780-10341	1
14	滚针轴承1924/8	NEEDLE BEARING	GB2581-76	2	47	空转带轮	LOOSE PULLEY ASM	780-10342	1
15	针杆曲柄左旋螺钉	LEFT SCREW	780-10315	1	48	轴用弹性挡圈30	RETAINING RING 30	GB894-76	1
16	油毡圈	OIL FELT WASHER	780-10316	1	49	螺钉9/64-40, L=3.5	SCREW 9/64-40 L=3.5	780-10343	3
17	止推垫圈	NEEDLE ROD CRANK WASHER	780-10317	1	50	带轮轴承盖	MAIN SHAFT THRUST SEAL	780-10344	1
18	螺钉	SCREW 9/32-28 L=16	780-10318	1	51	带轮轴承盖衬垫	GASKET	780-10345	1
19	平衡块	COUNTERWEIGHT	780-10319	1	52	滚针轴承前后盖	THRUST WASHER A	780-10346	2
20	螺钉1/4-40, L=5	SCREW 1/4-40 L=5	780-10320	2	53	推力滚针轴承589102	BEARING	JB2581-76	1
21	螺钉9/32-28, L=15.8	SCREW 9/32-28 L=15.8	780-10321	1	54	螺钉1/4-40, L=5.0	SCREW 1/4-40 L=5.0	780-10348	1
22	上轴前轴承	BUSHING FRONT	6204-2Z	1	55	螺钉1/4-40, L=5.0	SCREW 1/4-40 L=5	780-10320	1
23	螺钉1/4-40 L=6	SCREW 1/4-40 L=6	780-10331	6	56	传动带轮	DRIVING PULLEY	780-10349	1
24	上轴前轴承定位套	BUSHING FRONT POSITION SET	780A-10324	1	57	螺钉	SCREW (C)	780-10350	1
25	轴用挡圈φ25	RETAINING RING 25	GB/T894.1-1986	1	58	止动凸轮压簧	STOP CAM PRESSURE SPRING	780-10351	1
26	刀杆传动连杆	KNIFE BAR DRIVING CONNECTING ROD	780A-10326	1	59	止动凸轮压滑块	STOP MOTION CAM PIN SLIDE BLOCK	780-10352	2
27	刀杆传动偏心凸轮	KNIFE BAR DRIVING ECCENTRIC	780A-10327	1	60	扇形止动块	BAKE ITE SEGMENT	780-10353	1
28	螺钉1/4-40, L=8	SCREW 1/4-40 L=8	780-10328	2	61	止动凸轮定位销	STOP MOTION CAM POSITION PIN	780-10354	1
29	无套圈有保持架滚针轴承	NEEDLE BEARING	GB228-76	1	62	止动凸轮	STOP MOTION CAM	780-10355	1
30	轴承	BEARING	61904-Z	1	63	止动凸轮压圈	STOP MOTION CAM PRESSER PLATE	780-10356	1
31	螺钉15/64-28, L=10.5	SCREW 15/64-28 L=10.5	780-10302	1	64	螺钉11/64-40, L=7	SCREW 11/64-40 L=7	780-10140	3
32	WORM ASM	TENSTON POST NO.3	780-10330	1	65	带轮旋转方向标识贴	DIRECTION LABEL	780-10357	1
33	螺钉1/4-40, L=6	SCREW 1/4-40 L=6	780-10331	2	66	挑线杆曲柄	HINGE CRANK	780-10311	1
					67	轴承80106	BEARING	GB278-76	1
					68	偏心凸轮挡圈	ECCENTRIC CAM RETAINING RING	780A-10358	1

4. 下轴部件 HOOK DRIVING SHAFT COMPONENTS

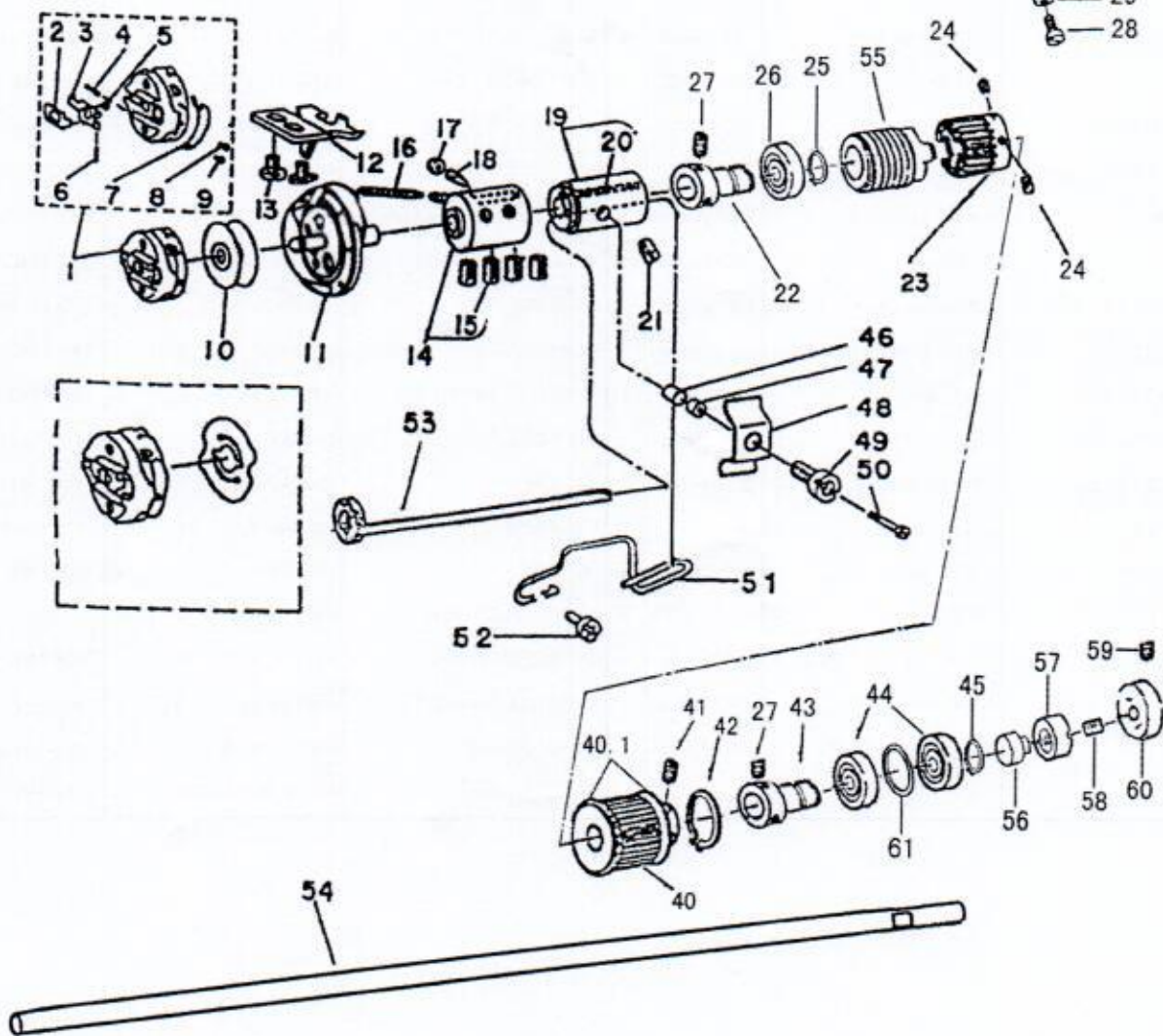
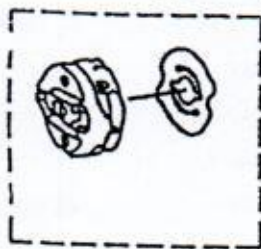
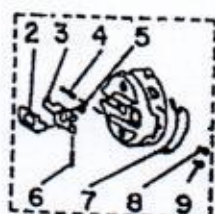
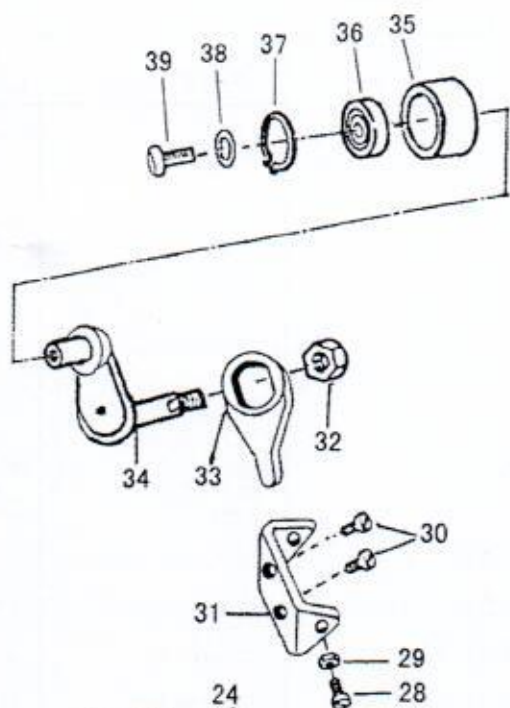
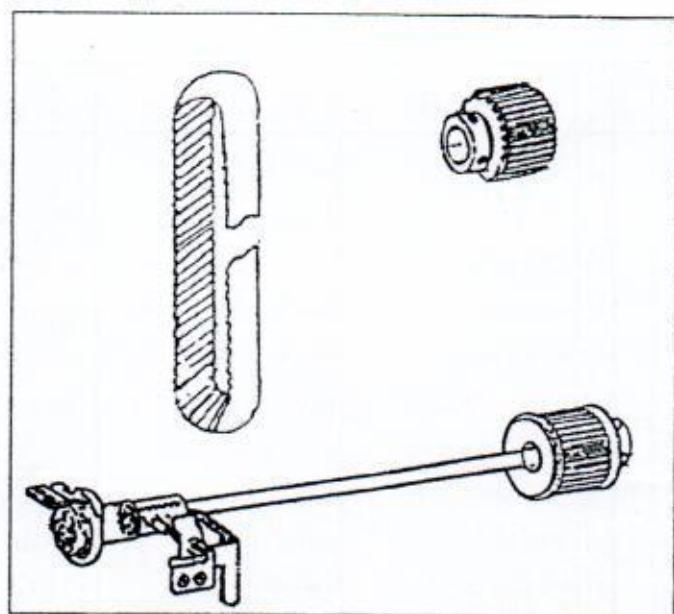

4. 下轴部件 HOOK DRIVING SHAFT COMPONENTS

序号	零件名称	Description	制造件号 (标准件规格)	数量	序号	零件名称	Description	制造件号 (标准件规格)	数量
1	梭壳组件	BOBBIN CASE ASM	佐文SC70-771	1	32	张紧轮连杆螺母	NUT 5/16-20	780A-10412	1
					33	调节配件	REGULATE ACCESSORIES	780A-10413	1
					34	张紧轴连杆	CONNECT A POLE BRDG TO THE SPROCKET SHAFT	780A-10414	1
					35	皮带张紧轮	BRING TO THE STRETCH A BEND	780A-10415	1
					36	轴承26×10×8	BEARING	6000	1
					37	孔用挡圈 φ26	RETAINING RING 26	GB893-76	1
					38	垫圈 4.8×11.5×2	WASHER 4.8×11.5×2	9-2-185	1
10	梭心	BOBBIN	780-10401	1	39	螺钉3/16-32 L=9.5	SCREW 3/16-32 L=9.5	780-11512	1
11	旋梭	HOOK ASM	佐文B088-771-060	1	40	下轴同步带轮	HOOK DRIVING SHAFT SPROCKET	780A-10417	1
12	定位钩	BOBBIN CASE POSITIONING PLATE	780-10402	1	41	无头螺钉 M6×7	SCREW M6×7	GB/T77-2000	2
13	螺钉11/64-40, L=5	SCREW 11/64-40 L=5	780-10158	2	42	孔用挡圈 φ32	RETAINING RING 32	GB893-76	1
14	旋梭轴接套组件	HOOK SLEEVE ASM	780-10403	1	43	后轴承定位套	BEARING BUSH REAR	780A-10418	1
15	螺钉1/4-40, L=6	SCREW 1/4-40 L=6	780-10404	4	44	轴承32×15×9	BEARING	6002	2
16	油芯	OIL WICK	780-10405	1	45	轴用挡圈 φ15	RETAINING RING 15	GB894-76	1
17	螺母9/64-40	NUT 9/64-40	780-10406	1	46	油量调节橡胶塞	HOOK OIL SUPPLY RUBBER ASM	780-10426	1
18	油量调节螺母	ADJUSTING SCREW	780-10407	1	47	油量调节橡胶嵌件	BUSHING	780-10427	1
19	下轴前轴承	BUSHLING ASM FRONT	780-10408	1	48	油量调节橡胶嵌钉座	PLATE SPRING	780-10428	1
20	油芯	OIL WICK	780-10405	1	49	旋梭油量调节螺钉	HOOK OIL ADJUSTING SCREW	780-10429	1
21	螺钉15/64-28, L=7	SCREW 15/64-28 L=7	780-10323	3	50	定位螺钉	POSITIONING SCREW	780-10430	1
22	中轴承定位套	BEARING BUSH INTERMEDIATE	780A-10409	1	51	油毡夹	OIL SUPPLY FELT HOLDER	780-10431	1
23	针杆摆动小齿轮	PINION ASM	780A-10410	1	52	螺钉15/64-28, L=7	SCREW 15/64-28 L=7	780-10432	1
24	螺钉1/4-40, L=6	SCREW 1/4-40 L=6	780-10331	2	53	下轴前轴承长油毡	OIL SUPPLY FELT	780-10434	1
25	轴用挡圈 φ12	RETAINING RING 12	GB894-76	1	54	下轴	HOOK DRIVING SHAFT	780A-10435	1
26	轴承28×12×8	BEARING	6001	1	55	油泵蜗杆	OIL PUMP WORM ASM	780A-10436	1
27	螺钉 3/16-32 L=5	SCREW 3/16-32 L=5	780-11117	4	56	垫块	MAT PIECE	780A-10437	1
28	螺钉 M4×14	SCREW M4×14	GB/T76.1-2000	2	57	后轴承调节螺母	BEARING REGULATE NUT, REAR	780A-10438	1
29	螺母 M4	NUT M4	GB52-76	2	58	紧定螺钉9/16-24 L=8	SCREW 9/16-24 L=8	780A-10439	1
30	螺钉9/64-40, L=8	SCREW 9/64-40 L=8	780-10631	2	59	螺钉11/64-40 L=7	SCREW 11/64-40 L=7	780-10111	1
31	调节杆座	REGULATE A POLE SHELF	780A-10411	1	60	后轴承固定套	BEARING PEG, REAR	780A-10440	1
					61	后轴承隔圈	BUSHING BEHIND RING	780A-10441	1

5. 压棒及送料部件 PRESSER BAR. WORK CLAMP CARRIER COMPONENTS

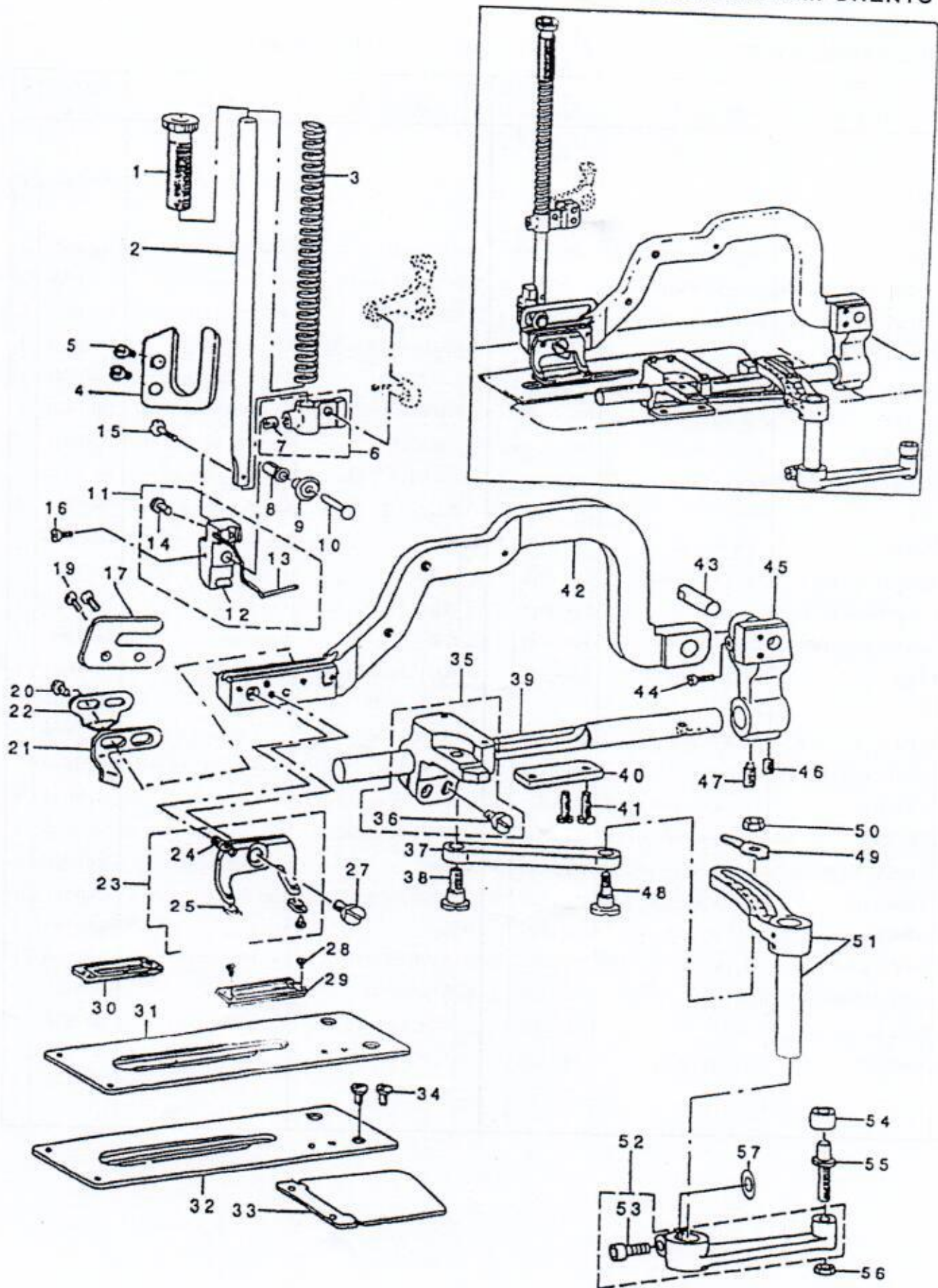

5. 压棒及送料部件 PRESSER BAR WORK CLAMP CARRIER COMPONENTS

序号	零件名称	Description	制造件号 (标准件规格)	数量	序号	零件名称	Description	制造件号 (标准件规格)	数量
1	压簧调节螺钉	PRESSER SPRING REGULATOR	780-10501	1					
2	压棒	PRESSER BAR	780A-10502	1	31	送布拖板	WORK CLAMP CARRIER	780-10527	1
3	压簧	PRESSER SPRING	780-10503	1					
4	压棒导向支架	PRESSER BAR GUIDE BRACKET	780A-10504	1	33	支架盖板组件	BRACKET COVER	780-10528	1
5	导架螺钉9/64-40 L=6.8	SCREW 9/64-40 L=6.8	780-10512	2	34	螺钉11/64-40, L=8	SCREW 11/64-40 L=8	780-10529	2
6	压棒定位架	PRESSER BAR POSITION BRACKET A	780A-10506	1	35	送料支架	WORK CLAMP ARM BRACKET ASM	780-10530	1
7	螺钉1/4-40, L=8	SCREW 1/4-40 L=8	780-10328	1	36	螺钉15/64-28, L=14	SCREW 15/64-28 L=14	780-10531	1
8	轴承	COLLAR	780-10507	1	37	送料支架连杆	WORK CLAMP CARRIER BRACKET PIN	780-10532	1
9	滑动滚轮	SLIDE ROLLER	780-10508	1	38	铰链销螺钉D=8, 73 H=6.0	HINGE SCREW D=8, 73 H=6.0	780-10533	1
10	滑动滚轮销	CONNECTING PIN	780-10509	1	39	压脚臂滑杆	WORK CLAMP ARM SLIDE ROD	780-10534	1
11	支架组件	BRACKET ASM	780-10510	1	40	送布拖板支架导板	WORK CLAMP CARRIER BRACKET GUIDE	780-10535	1
12	支架	BRACKET	780-10510	1	41	螺钉9/64-40, L=9.5	SCREW 9/64-40 L=9.5	780-10536	2
13	保险架	FINGER GUARD	780-10511	1	42	布料夹	WORK CLAMP	780A-10537	1
14	螺钉9/64-40, L=6.8	SCREW 9/64-40 L=6.8	780-10512	1	43	连接销	CONNECTING PIN	780-10538	1
15	压棒螺钉9/64-40, L=15	SCREW 9/64-40 L=15	780-10513	1	44	螺钉15/64-40, L=8.5	SCREW 15/64-40 L=8.5	780-10539	1
16	螺钉11/64-40, L=7	SCREW 11/64-40 L=7	780-10140	1	45	托架	BEARING ARM	780-10540	1
17	压脚架	WORK CLAMP BRACKET	780A-10514	1	46	螺钉15/64-28, L=7	SCREW 15/64-28 L=7	780-10323	1
					47	螺钉15/64-28, L=11	SET-SCREW	780-10541	1
19	螺钉9/64-40, L=8.5	SCREW 9/64-40 L=8.5	780-10631	2	48	调节送料长度铰链销螺钉	LENGTH REGULATING HINGE STUD	780-10542	1
20	螺钉11/64-40, L=7.8	SCREW 11/64-40 L=7.8	780-10516	2	49	调节送料长度轴导板	LENGTH REGULATING SHAFT GUIDE	780-10543	1
21	闭剪控制板	NEEDLE THREAD TRIMMER GUIDE A	780-10517	1	50	螺母15/64-28	NUT 15/64-28	780-10544	1
22	开剪控制板	NEEDLE THREAD TRIMMER GUIDE B	780-10518	1	51	调节送料长度刻度盘	LENGTH REGULATING SCALE ASM	780-10545	1
23	压脚板座	WORK CLAMP CHECK HOLDER ASM	780-10519	1	52	曲柄	CLOTH FEED ARM ASM	780-10546	1
24	压脚板座弹簧销	WORK CLAMP CHECK HOLDER SPRING	780-10520	1	53	圆柱内六角螺钉6×16	SCREW M6 L=16	GB70-76	1
25	压脚弹簧板	WORK CLAMP CHECK SPRING	780-10521	2	54	滚子	ROLLER	780A-10547	1
26	压脚弹簧定位销	WORK CLAMP CHECK SPRING SET PIN	780-10522	2	55	曲柄滚子销螺钉	BELL CRANK ROLLER STUD	780-10548	1
27	压脚板座轴位螺钉	HINGE SCREW	780-10523	1	56	螺母15/64-28	NUT 15/64-28	780-10544	1
28	螺钉3/32-56, L=1.9	SCREW 3/32-56 L=1.9	780-10524	2	57	垫圈6.5×13×0.8	WASHER 6.5×13×0.8	780-10549	1
29	压脚板组件	WORK CLAMP CHECK	780-10525	1					

6. 针杆架部件 NEEDLE BAR FRAME COMPONENTS

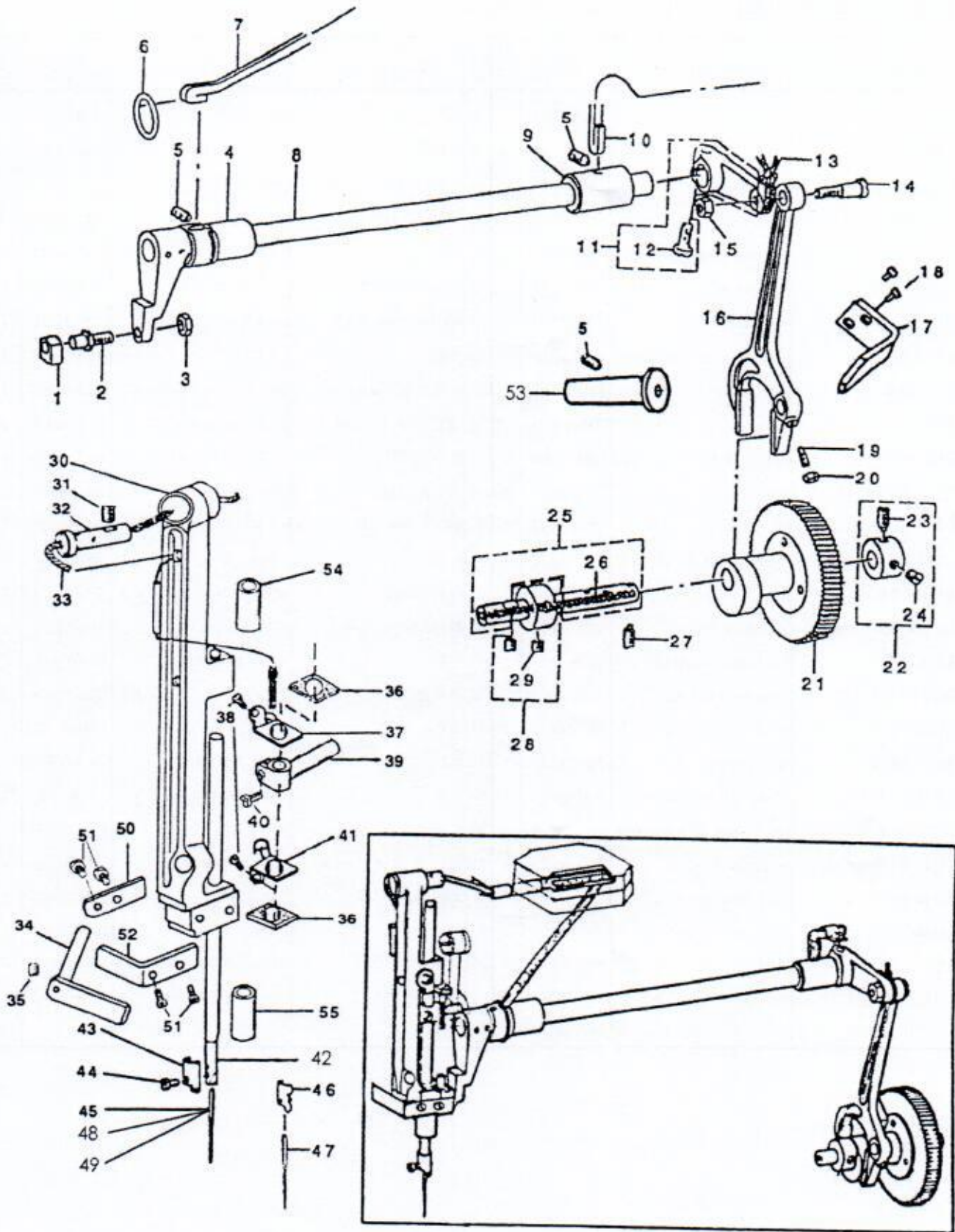

6. 针杆架部件 NEEDLE BAR FRAME COMPONENTS

序号	零件名称	Description	制造件号 (标准件规格)	数量	序号	零件名称	Description	制造件号 (标准件规格)	数量
1	针杆架传动滑块	SQUARE BLOCK	780A-10601	1	29	螺钉15/64-28, L=7	SCREW 15/64-28 L=7	780-10323	1
2	滑块销螺钉	STUD	780A-10602	1	30	针杆摆架	NEEDLE BAR FRAME	780A-10622	1
3	螺母15/64-28	NUT 15/64-28	780-10544	1	31	螺钉15/64-28, L=8	SCREW 15/64-28 L=8	5-41-185	1
4	摆杆前轴承	BUSHING	780A-10603	1	32	针杆摆架铰链销	HINGE STUD	780A-10624	2
5	螺钉15/64-28, L=10.5	SCREW 15/64-28 L=10.5	780-10302	3	33	油芯	OIL WICK	780-10611	1
6	油毡夹紧环20×2.4	RUBBER RING	GB1235-76	1	34	针杆摆动架定位架	POSITION BRACKET	780A-10625	1
7	油毡	OIL WICK	780-10605	1	35	螺钉15/64-28, L=4.7	SCREW 15/64-28 L=4.7	780-11116	1
8	摆杆前曲柄	FRAME ROCK SHAFT CRANK ASM F	780A-10606	1	36	油毡	OIL FELT	780-10626	1
9	摆杆后轴承	BUSHING REAR	780-10607	1	37	油绳高端固定架	ROCK SHAFT CONNECTION GUIDE	780A-10627	1
10	油毡	OIL FELT	780-10608	1	38	螺钉9/64-40, L=4.5	SCREW 9/64-40 L=4.5	780-10628	2
11	摆杆后曲柄	FRAME ROCK SHAFT CRANK ASM R	780A-10609	1	39	针杆连接杆	NEEDLE BAR CONNECTION	780A-10629	1
12	螺钉15/64-28, L=12	SCREW 15/64-28 L=12	780-10610	1	40	螺钉9/64-40, L=8.5	SCREW 9/64-40 L=8.5	780-10631	1
13	油芯	OIL WICK	780-10611	1	41	油绳低端固定架	OIL FELT RETAINER LOWER	780A-10632	2
14	摆动叉铰链销螺钉D=7.94H=8	HINGE SCREW D=7.94 H=8	780-10612	1	42	针杆	NEEDLE BAR	780-10633	1
15	螺母1/4-24	NUT 1/4-24	780-10613	1	43	针杆导线架	NEEDLE BAR BOBBIN THREAD GUIDE	780-10634	1
16	针杆摆动叉	NEEDLE BAR PITMAN	780-10614	1	44	螺钉1/8-44, L=4.5	SCREW 1/8-44 L=4.5	780-10635	1
17	摆动叉导板	ROCK SHAFT CONNECTION GUIDE	780A-10615	1	45	机针	NEEDLE DP×5 #11J	DP×5 #11J	1
18	螺钉9/64-40, L=8.5	SCREW 9/64-40 L=8.5	780A-10616	2	46	针杆导线架	NEEDLE BAR BOBBIN THREAD GUIDE	780-10636	1
19	螺钉11/64-40, L=12	SCREW 11/64-40 L=12	780-10617	1	47	机针	NEEDLE 134SES 75	134ES 75	1
20	螺母11/64-40	NUT 11/64-40	780-10211	1	48	机针	NEEDLE DP×5 #14J	DP×5 #14	1
21	机针摆凸轮组件	NEEDLE DRIVING GEAR ASM	780-10618	1	49	机针	NEEDLE 134 75	134 75	1
22	机针摆凸轮挡圈D=9.53W=10	THRUST COLLAR ASM D=9.53 W=10	780-10619	1	50	左固定片	LEFT STATOR	780A-10637	1
23	螺钉15/64-28, L=11	SET-SCREW	780-10541	1	51	螺钉 9/64-40 L=6.8	SCREW 9/64-40 L=6.8	780-10512	4
24	螺钉15/64-28, L=7	SCREW 15/64-28 L=7	780-10323	1	52	右固定片	RIGHT STATOR	780A-10638	1
25	机针摆凸轮轴	KNIFE DRIVING SHAFT ASM	780-10620	1	53	轴心	AXIS	780A-10639	1
26	油芯	OIL WICK	780-10621	/	54	针杆衬套管(上)	NEEDLE BAR BUSH (HIGH)	780A-10640	1
27	螺钉15/64-28, L=11	SET-SCREW	780-10541	/	55	针杆衬套管(下)	NEEDLE BAR BUSH (LOW)	780A-10641	1
28	机针摆凸轮挡圈D=9.53W=10	THRUST COLLAR ASM D=9.53 W=10	780-10619	/					

7. 针摆幅度调节部件 OVEREDGING WIDTH ADJUSTING COMPONENTS

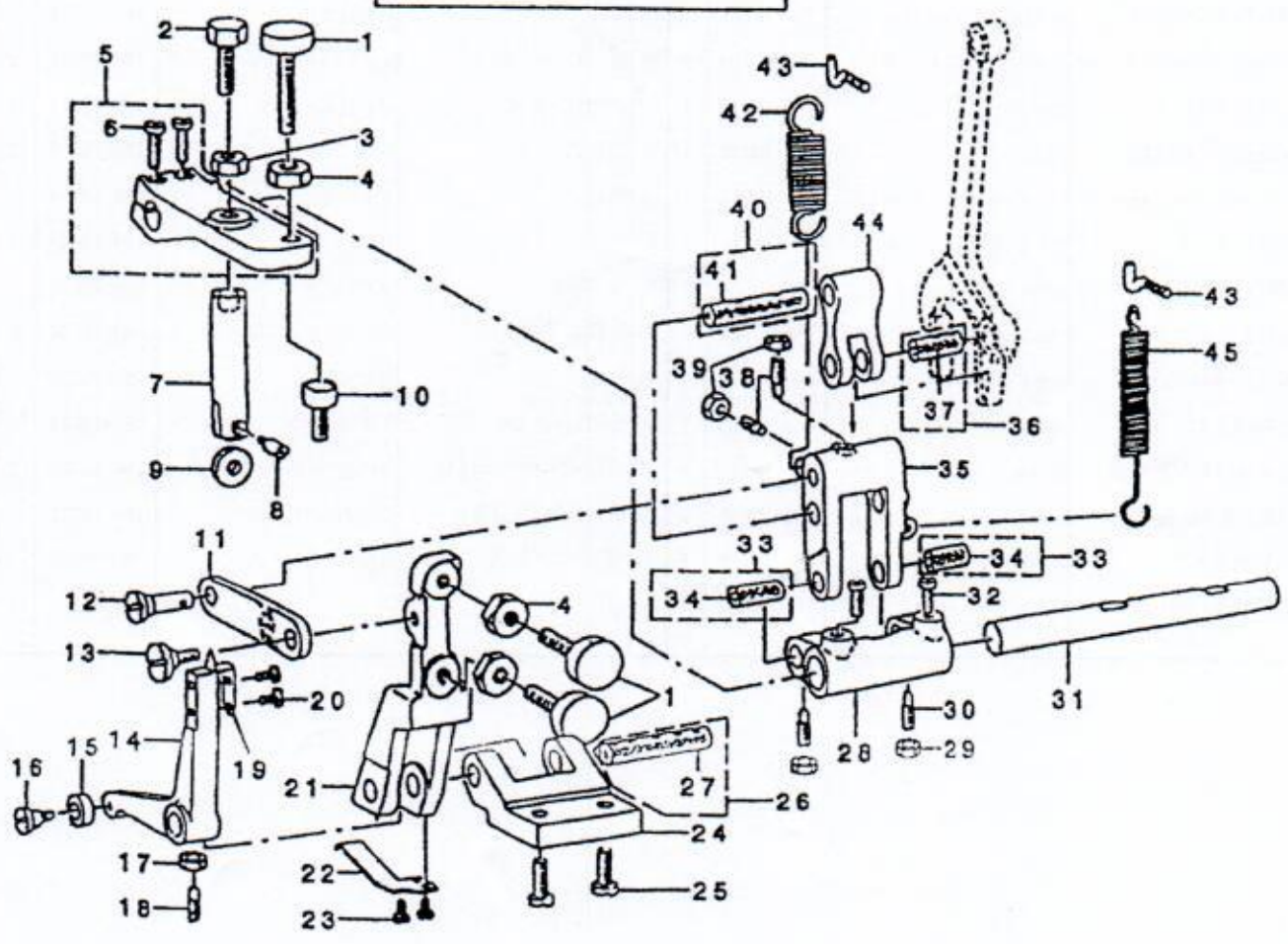
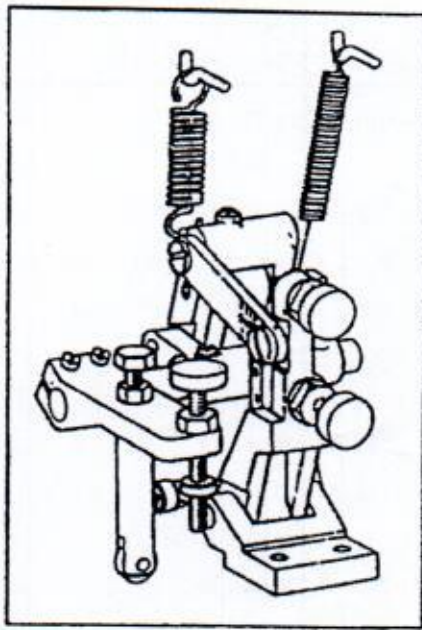

7. 针摆幅度调节部件 OVEREDGING WIDTH ADJUSTING COMPONENTS

序号	零件名称	Description	制造件号 (标准件规格)	数量	序号	零件名称	Description	制造件号 (标准件规格)	数量
1	基线调节螺钉	STICH WIDTH REGULATING SCREW	780-10701	3	26	调节架轴	REGULATING LEVER SHAFT ASM	780-10718	1
2	调节螺钉 MS, L=20	SCREW MS L=20	780-10733	1	27	油芯	OIL WICK	780-10736	1
3	左基线调节螺母	NUT M8	780-10732	1	28	基线变换架	BEARING BRACKET	780-10719	1
4	螺母 MS	NUT M8	GB41-76	3	29	螺母11/64-40	NUT 11/64-40	780-10211	1
5	基线调节柄	REPOSITIONING LEVER ASM	780-10702	1	30	螺钉11/64-40, L=12	SCREW 11/64-40 L=12	780-10617	1
6	螺钉	SCREW 3/16-28 L=12	780-10703	2	31	基线变换架轴	NEEDLE THROW REPOSITIONING SHA	780-10720	1
7	基线变换顶杆	TRIPPING ROD ASM	780-10704	1	32	螺钉15/64-28, L=9	SCREW 15/64-28 L=9	780-10721	2
8	滚轮销轴螺钉	PIN	780-10705	1	33	连接销	BEARING BRACKET ASM	780-10722	2
9	滚轮	ROLLER	780-10706	1	34	油芯	OIL WICK	780-10737	2
10	基线调节柄限位螺钉	REGULATING LEVER STOPPER ASM	780-10707	1	35	振幅变换架	REPOSITIONING LIVER LINK	780-10723	1
11	振幅调节连杆	REGULATING LEVER CONNECTION	780-10708	1	36	连接销	CONNECTING FORKED LINK PIN ASM	780-10724	1
12	振幅调节连杆铰链销	REGULATING HINGE PIN	780-10709	1	37	油芯	OIL WICK	780-10734	1
13	振幅连杆铰链螺钉 D=7.94 H=4.3	HINGE SCREW D=7.94 H=4.3	780-10710	1	38	螺钉11/64-40, L=12	SCREW 11/64-40 L=12	780-10617	2
14	加固变换顶杆	BELL CRANK	780-10711	1	39	螺母11/64-40	NUT 11/64-40	780-10211	2
15	加固变换顶杆滚轮	ROLLER	780-10712	1	40	连接销	CONNECTING STUD ASM	780-10725	1
16	滚轮铰链螺钉 D=6.35 H=4.7	HINGE SCREW D=6.35 H=4.7	780-10713	1	41	油芯	OIL WICK	780-10735	1
17	螺母11/64-40	NUT 11/64-40	780-10211	1	42	拉簧	SPRING	780-10726	1
18	螺钉11/64-40, L=12	SCREW 11/64-40 L=12	780-10617	1	43	悬挂螺钉	SUSPENSION SCREW	780-10727	2
19	加固振幅宽度指针	BARRED WIDTH INDICATOR	780-10714	1	44	针杆架摆动螺钉	CONNECTING FORKED LINK	780-10728	1
20	螺钉1/8-44, L=4.5	SCREW 1/8-44 L=4.5	780-10635	2	45	拉簧	SPRING	780-10729	1
21	振幅调节架	REGULATING LEVER	780-10715	1	46	螺母15/64-28	NUT 15/64-28	780-10544	1
22	变换顶杆复位弹簧板	SPRING	780-10716	1	47	基线调节柄限位螺钉	REGULATING LEVER STOPPER ASM	780-10707	1
23	螺钉1/8-44, L=4.5	SCREW 1/8-44 L=4.5	780-10635	2	48	横列振幅宽度指针	SEAM WIDTH INDICATOR	780-10731	1
24	振幅调节架座	REGULATING LEVER BRACKET	780-10717	1	49	螺钉1/8-44, L=4.5	SCREW 1/8-44 L=4.5	780-10635	2
25	螺钉15/64-28, L=12	SCREW 15/64-28 L=12	780-10610	2					

8. 剪面线器部件 NEEDLE THREAD TRIMMER COMPONENTS

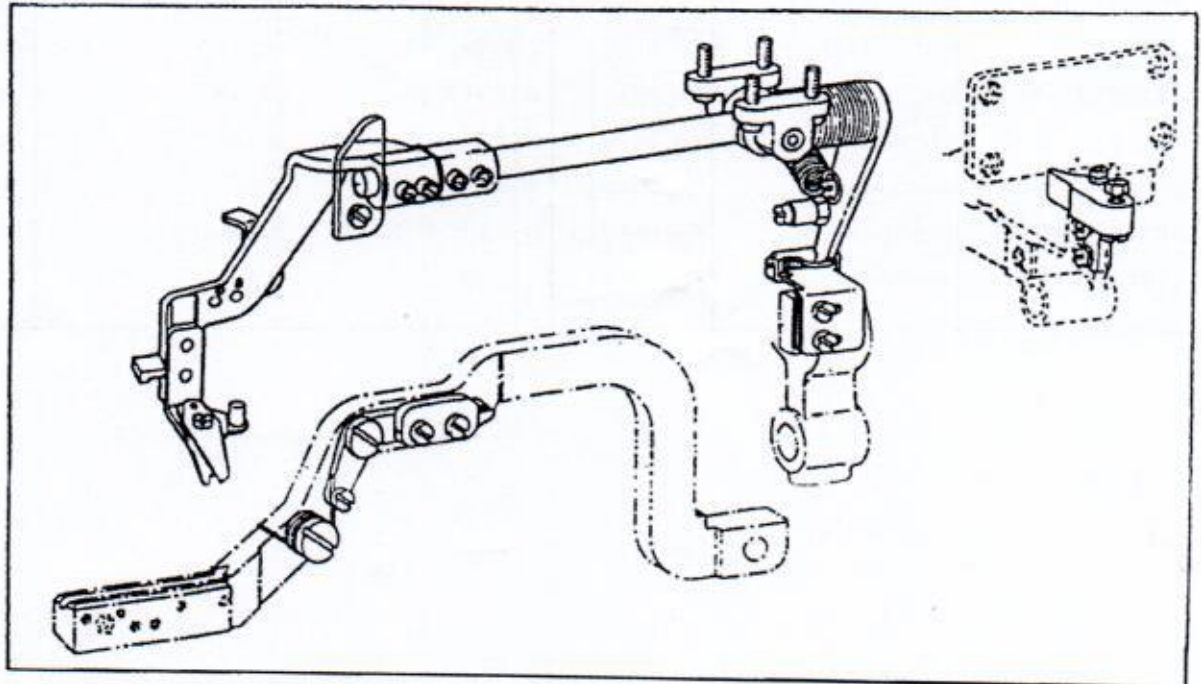
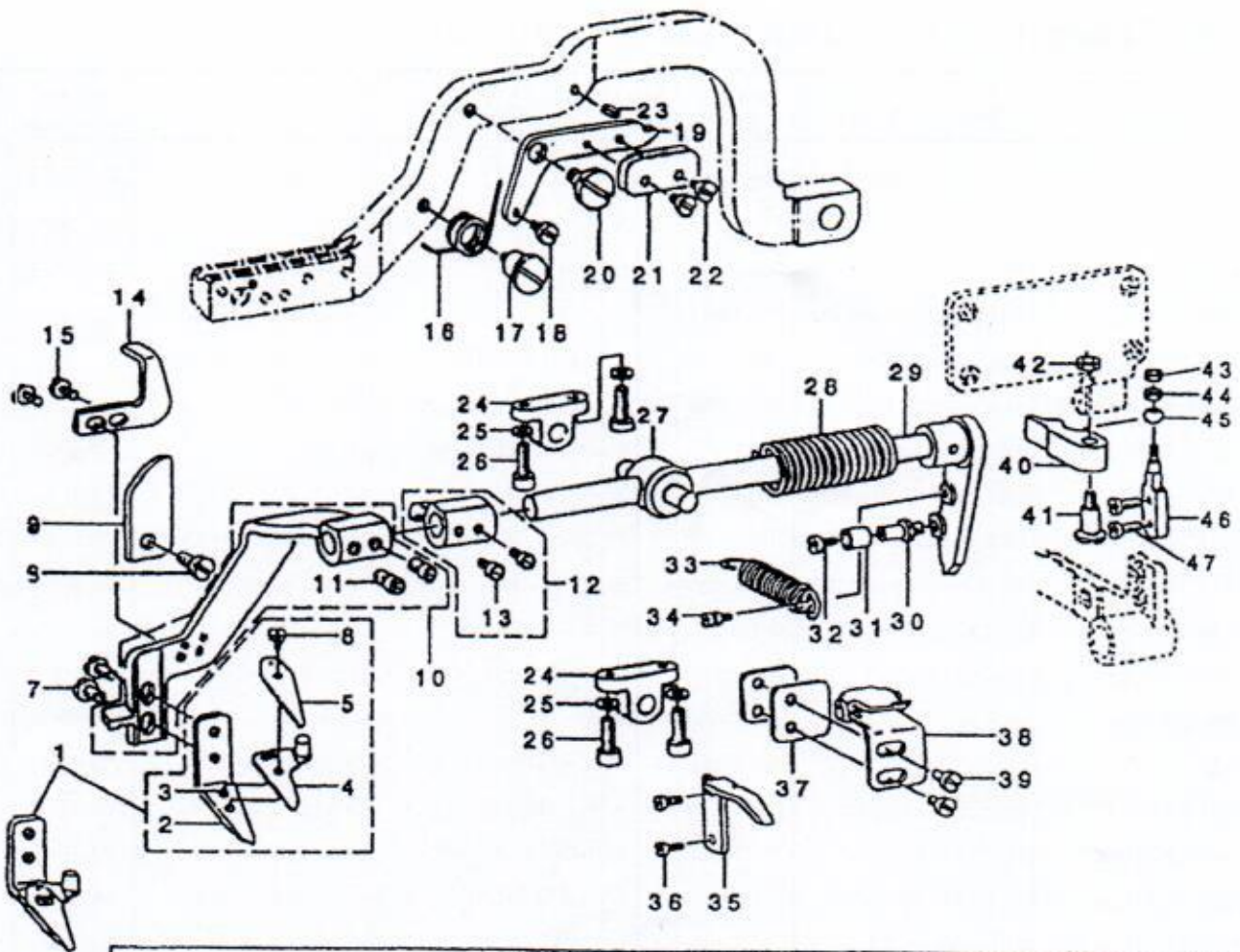

8. 剪面线器部件 NEEDLE THREAD TRIMMER COMPONENTS

序号	零件名称	Description	制造件号 (标准件规格)	数量	序号	零件名称	Description	制造件号 (标准件规格)	数量
1	面线修正器组件	NEEDLE THREAD TRIMMER ASM	780-10801	1	25	垫圈5.2×8.2×1	SPRING WASHER 5.2×8.2×1	780-10820	4
2	面线剪刀下刀片	NEEDLE THREAD TRIMMER LOWER	780-10802	1	26	圆柱头内六角螺钉3/16-32, L=12	SCREW 3/16-32 L=12.0	780-10821	4
3	定位销	POSITION PIN	780-10803	1	27	万向接头	UNIVERSAL JOINT	780-10822	1
4	面线剪刀上刀片	NEEDLE THREAD TRIMMER UPPER	780-10804	1	28	弹簧	THREAD TRIMMER SPRING B	780-10823	1
5	面线剪刀压簧板	NEEDLE THREAD PRESSER SPRNG	780-10805	1	29	剪面线器轴组件	NEEDLE THREAD TRIMMER SHAFT ASM	780-10824	1
6	铰链销螺钉D=4, H=1.8	HINGE SCREW D=4 H=1.8	780-10806	1	30	面线剪刀起动滚轮销	STUD	780-10825	1
7	螺钉11/64-40, L=5	SCREW 11/64-40 L=5	780-10158	2	31	面线剪刀起动滚轮	CAM ROLL	780-10826	1
8	剪面线器轴导板	NEEDLE THREAD TRIMMER SHAFT GD	780-10807	1	32	螺钉1/8-44, L=6	SCREW 1/8-44 L=6	780-10827	1
9	螺钉15/64-28, L=7	SCREW 15/64-28 L=7	780-10808	1	33	面线剪刀复位拉簧	THREAD TRIMMER SPRING A	780-10828	1
10	面线剪刀摆动架	THREAD TRIMMER HOLDER ASM	780A-10809	1	34	拉簧悬挂螺钉	SUSPENSION SCREW	780-10829	1
11	支头螺钉M6×10	SCREW M6 L=10	GB-T78-1985	2	35	线头控制器压板	LATCH PRESSER ARM	780-10830	1
12	面线剪刀安全曲柄	DIFFERENTIAL HOLDER ASM	780-10811	1	36	螺钉9/64-40, L=6.8	SCREW 9/64-40 L=6.8	780-10512	2
13	支头螺钉M6×10	SCREW M6 L=10	GB-T78-1985	2	37	垫片	SPACER	780-10831	1
14	限位板	LIMITING PLATE	780A-10812	1	38	锁架组件	LOCKING BRACKET LATCH ASM	780-10832	1
15	螺钉11/64-40, L=7.8	SCREW 11/64-40 L=7.8	780-10516	2	39	螺钉11/64-40, L=7.8	SCREW 11/64-40 L=7.8	780-10516	2
16	安全凸轮转矩弹簧	DRIVING CAM SPRING	780-10813	1	40	剪线轴运动量顶块	THREAD TRIMMING SHAFT SEGMENT	780-10833	1
17	安全凸轮转矩弹簧轴	DRIVING CAM SPRING AXLE	780-10814	1	41	铰链销螺钉D=6.35, H=10	HINGE SCREW D=6.35 H=10	780-10834	1
18	铰链销螺钉D=4.5, H=4	HINGE SCREW D=4.5 H=4	780-10815	1	42	螺母11/64-40	NUT 11/64-40	780-10211	1
19	安全凸轮安装板	DRIVING CAM INSTALLING PLATE	780-10816	1	43	螺母1/8-44	NUT 1/8-44	780-10836	1
20	铰链销螺钉D=7.94, H=3.0	HINGE SCREW D=7.94 H=3.0	780-10817	1	44	螺母1/8-44	NUT 1/8-44	780-10835	1
21	安全凸轮板	DRIVING CAM	780-10818	1	45	滚柱	ROLLER	780-10837	1
22	螺钉9/64-40, L=6.8	SCREW 9/64-40 L=6.8	780-10512	2	46	滚柱轴	STUD	780-10838	1
23	弹性圆柱销3×10	SPRING PIN 3.0×10	GB/T879-1986	1	47	螺钉11/64-40, L=7.8	SCREW 11/64-40 L=7.8	780-10516	2
24	万向接头座	BRACKET	780-10819	1					

9. 剪底线器部件 BOBBIN THREAD TRIMMER COMPONENTS

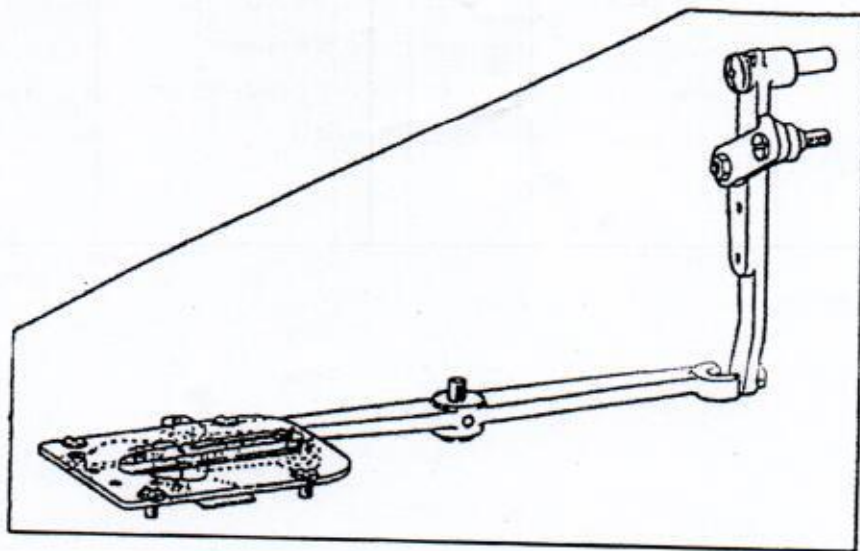
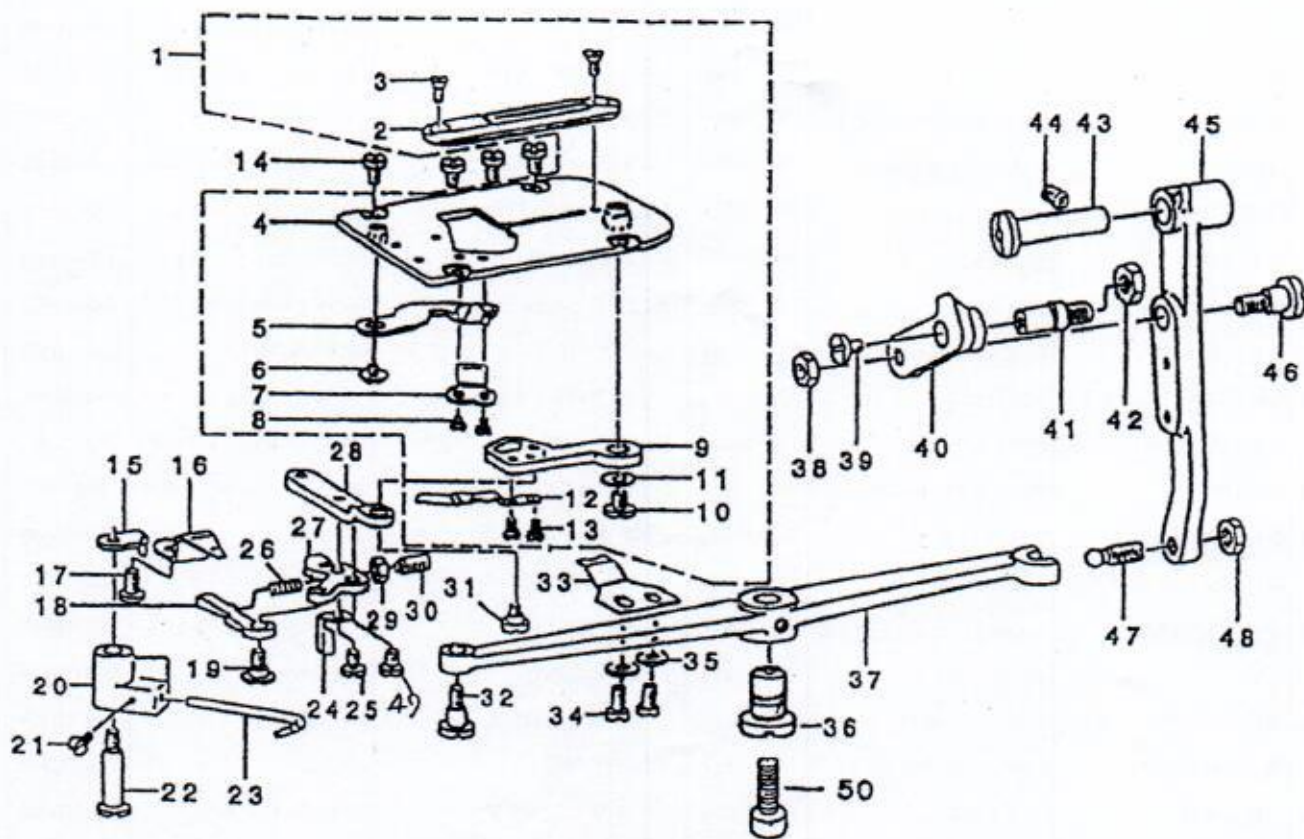

9. 剪底线器部件 BOBBIN THREAD TRIMMER COMPONENTS

序号	零件名称	Description	制造件号 (标准件规格)	数量	序号	零件名称	Description	制造件号 (标准件规格)	数量
1	剪底线器组件	NEEDLE PLATE ASM	780-10901	1	26	压板调节弹簧	PRESSER PLATE ADJUSTING SPRING	780-10925	1
2	针板	NEEDLE PLATE	780-10902	1	27	顶杆座	PRESSER PLATE MOUNTING BASE	780-10926	1
3	螺钉9/64-40, L=5	SCREW 9/64-40 L=5	780-10903	2	28	剪底线连杆	BOBBIN THREAD TRIMMER LINK	780-10927	1
4	针板座组件	THROAT PLATE BASE ASM	780-10904	1	29	螺母	NUT 3/16-28	780-10928	1
5	剪底线动力刀	BOBBIN THREAD TRIMMER BEADE AS	780-10905	1	30	压板调节螺钉	PRESSER PLATE ADJUSTING SCREW	780-10929	1
6	螺钉9/64-40, L=3.2	SCREW 9/64-40 L=3.2	780-10906	1	31	铰链销螺钉D=6.35 H=3.2	HINGE SCREW D=6.35 H=3.2	780-10930	1
7	剪底线定刀	COUNTER KNIFE	780-10907	1	32	铰链销螺钉D=6.35 H=6	HINGE SCREW D=6.35 H=6	780-10931	1
8	螺钉1/8-44, L=3.4	SCREW 1/8-44 L=3.4	780-10908	2	33	梭芯导线架	BOBBIN THREAD GUIDE	780-10932	1
9	剪底线杆	BOBBIN THREAD TRIMMER LEVER	780-10909	1	34	螺钉9/64-40, L=5	SCREW 9/64-40 L=5.0	780-10933	2
10	螺钉11/64-40, L=4.8	SCREW 11/64-40 L=4.8	780-10910	1	35	垫圈4.5×8×0.5	WASHER 4.5×8×0.5	780-10108	2
11	垫圈4.5×20×1	WASHER 4.5×20×1	780-10911	1	36	偏心套	LACK OF IMPARTIALITY THE SET	780A-10934	1
12	底线拉杆	BOBBIN THREAD PULLER	780-10912	1	37	剪底线传动连杆	BOBBIN THREAD TRIMMER DRIVING	780A-10935	1
13	螺钉9/64-40, L=4	SCREW 9/64-40 L=4	780-10913	2	38	螺母15/64-28	NUT 15/64-28	780-10544	1
14	螺钉9/64-40, L=6	SCREW 9/64-40 L=6	780-10914	4	39	螺钉11/64-40, L=4.8	SCREW 11/64-40 L=4.8	780-10936	1
15	旋梭线压力挡板	HOOK THREAD PRESSER STOPPER	780-10915	1	40	凸轮连杆	CONNECTING LINK	780-10937	1
16	压板	PRESSER PLATE	780-10916	1	41	轴位螺钉	STOP SCREW	780-10938	1
17	螺钉11/64-40, L=7.8	SCREW 11/64-40 L=7.8	780-10516	1	42	螺母9/32-28	NUT 9/32-28	780-10939	1
18	梭芯压杆顶杆	BOBBIN PICKER PRESSER PLATE	780-10917	1	43	铰链销	HINGE STED	780-10940	1
19	铰链销螺钉	HINGE SCREW	780-10918	1	44	螺钉15/64-28, L=7	SCREW 15/64-28 L=7	780-10323	1
20	梭芯压杆架	BOBBIN PICKER BRACKET	780-10919	1	45	剪底线器传动销	BOBBIN THREAD TRIMMER DRIVING	780-10941	1
21	螺钉9/64-40, L=6.1	SCREW 9/64-40 L=6.1	780-10920	1	46	铰链销螺钉D=7.94 H=6.4	HINGE SCREW D=7.94 H=6.4	780-10942	1
22	梭芯压杆架轴	BOBBIN PICKER BRACKET SHFT	780-10921	1	47	球形螺钉	BALL SCREW	780-10943	1
23	梭芯压杆	BOBBIN WINDER TRIP LATCH	780-10922	1	48	螺母15/64-28	NUT 15/64-28	780-10544	1
24	安全限位板	SAFETY STOPPE	780-10923	1	49	螺钉11/64-40, L=7	SCREW 11/64-40, L=7	780-10203	1
25	螺钉11/64-40, L=6	SCREW 11/64-40 L=6	780-10924	1	50	螺钉	SCREW	780A-10944	1

10. 刀杆部件 KNIFE BAR COMPONENTS

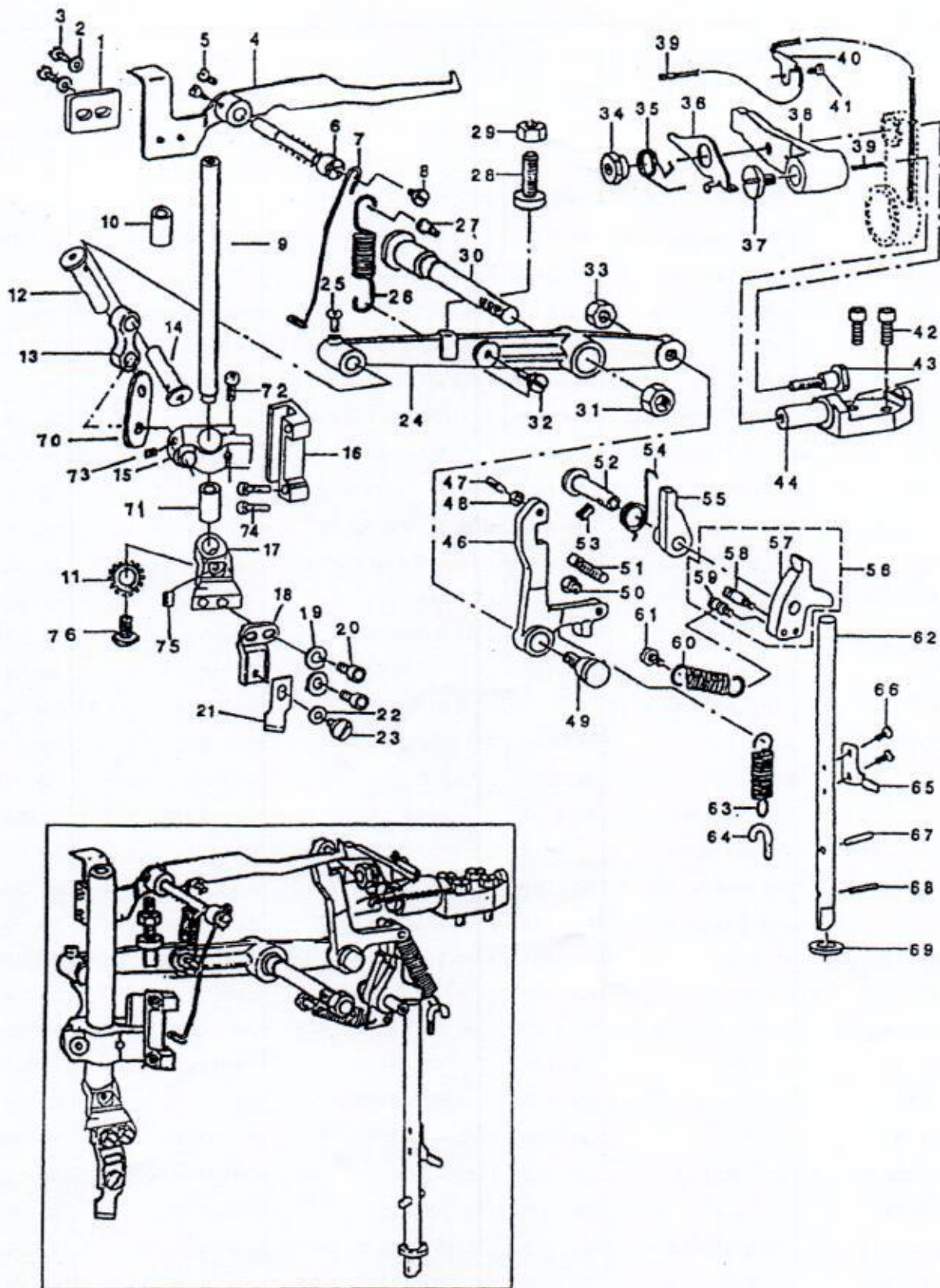

10. 刀杆部件 KNIFE BAR COMPONENTS

序号	零件名称	Description	制造件号 (标准件规格)	数量	序号	零件名称	Description	制造件号 (标准件规格)	数量
1	停刀杆平衡块	KNIFE STOP LEVER BRACKET	780-11001	1	39	油芯	OIL WICK	780-11041	1
2	垫圈4.8×8.4×0.8	WASHER 4.8×8.4×0.8	780-11002	2	40	油芯保持架	OIL WICK HOLDER	780-11034	1
3	螺钉11/64-40, L=7.8	SCREW 11/64-40 L=7.8	780-10516	2	41	螺钉9/64-40, L=6	SCREW 9/64-40 L=6	780-10123	1
4	停刀杆	KNIFE STOP LEVER	780-11004	1	42	圆柱内六角螺钉 6×20	SCREW M6 L=20	GB 70-76	2
5	螺钉11/64-40, L=7	SCREW 11/64-40 L=4.8	780-11005	2	43	驱动杆铰链销螺钉	HINGE SCREW D=11.11 H=9.0	780-11036	1
6	停刀杆铰链销	KNIFE STOP LEVER HINGE STUD	780-11006	1	44	切刀驱动杆轴座	KNIFE BAR DRIVING CRANK SHAFT	780A-11037	1
7	线检测钢丝	THREAD CHECK WIRE	780-11007	1					
8	螺钉11/64-40, L=7.8	SCREW 11/64-40 L=7.8	780-10516	1	46	切刀动作勾	KNIFE BAR DRIVING LEVER BELL C	780-11039	1
9	刀杆	KNIFE BAR	780A-11008A	1	47	螺钉11/64-40, L=15.5	SCREW 11/64-40 L=15.5	780-11040	1
10	刀杆上套	KNIFE BAR SET	780A-11009A	1	48	螺母11/64-40	NUT 11/64-40	780-10211	1
11	外齿锁紧垫圈φ6	LOCK TIGHT WASHER φ6	GB/T802.1-1987	1	49	驱动杆铰链销螺钉	HINGE SCREW D=11.11 H=9.0	780-11036	1
12	销轴	SELL THE STALK	780A-11010	1	50	螺母15/64-28	NUT	780-11042	1
13	刀杆连杆	KNIFE BAR CONNECTING LINK	780A-11011	1	51	切刀动作勾偏芯螺钉	PIN	780-11043	1
14	销轴	SELL THE STALK	780A-11012	1	52	切刀驱动爪铰链销	HINGE STUD	780-10940	1
15	刀杆定位架	KNIFE STUD RETAINER (B)	780A-11013A	1	53	螺钉15/64-28, L=7	SCREW 15/64-28 L=7	780-10323	1
16	刀杆导引	KNIFE BAR DIRECTION	780A-11014A	1	54	转矩弹簧	TENSION SPRING	780-11045	1
17	刀杆固定架	KNIFE BAR HOLDER	780A-11058A	2	55	切刀驱动爪轴块	RATCHET PAWL (B)	780-11046	1
18	刀固定架	KNIFE HOLDER	780-11015	1	56	切刀驱动爪主块组件	HOOK DIFFERENTIAL CLICK A ASM	780-11047	1
19	弹簧垫圈	SPRING WASHER 6.5×11×1.3	GB 93-76	2	57	切刀驱动爪主块	HOOK DIFFERENTIAL CLICK A	780-11048	1
20	圆柱内六角螺钉 6×12	SCREW M6 L=12	GB 70-76	2	58	弹簧挂钩	SPRING SUSPENSION	780-11049	1
21	1/2 切刀	KNIFE 1/2	780-11016	1	59	挂钩	THREAD CUTTING LINK SPRING HAC	780-11050	1
22	垫圈	WASHER 5×10.5×1	780-11017	1	60	切刀驱动爪拉簧	TENSION SPRING	780-11051	1
23	螺钉3/16-32, L=6.5	SCREW 3/16-32 L=6.5	780-11018	1	61	切刀驱动爪拉簧悬挂螺钉	HINGE SCREW D=5.30 H=2.2	780-11052	1
24	刀杆传动杆	KNIFE BAR DRIVING LEVER	780A-11019	1	62	切刀顶杆	DRIVING ROD	780-11053	1
25	螺钉11/64-40, L=8	SCREW 11/64-40 L=8	780-11020	1	63	切刀动作勾拉簧	TENSION SPRING	780-11054	1
26	刀杆传动杆复位拉簧	SPRING	780-11021	1	64	切刀动作勾拉簧螺钉	SUSPENSION SCREW	780-11055	1
27	复位拉簧悬挂螺钉(上)	HINGE SCREW D=5.5 H=5	780-11022	1	65	线头控制器轴杆	FINGER	780-11056	1
28	切刀动作勾调节螺钉	KNIFE BAR DRIVING LEVER ASM	780-11023	1	66	螺钉9/64-40, L=6.8	SCREW 9/64-40 L=6.8	780-10512	2
29	螺母5/16-18	NUT 5/16-18	780-11024	1	67	圆柱销4×18	POSITIONING PIN (B)	GB 119-76	1
30	刀杆传动杆轴	KNIFE BAR DRIVING LEVER SHAFT	780-11025	1	68	弹性圆柱销3×18	SPRING PIN 3×18	GB 879-76	1
31	螺母3/8-28	NUT 3/8-28	780-11026	1	69	切刀顶杆缓冲垫圈	THRUST WASHER	780-11057	1
32	复位拉簧悬挂螺钉(下)	HINGE SCREW D=7.9 H=2.0	780-11027	1	70	防油板	DEFEND OIL PLANK	780A-11059A	1
33	螺母5/16-24	NUT 5/16-24	780-11028	1	71	刀杆下套	KNIFE BAR NEXT	780A-11160A	1
34	切刀驱动杆螺母	KNIFE BAR DRIVING CRANK NUT	780-11029	1	72	螺钉3/16-32, L=9	SCREW 3/16-32 L=9	780A-11061A	1
35	锁紧板转矩弹簧	TENSION SPRING	780-11030	1	73	螺钉3/16-32, L=6.2	SCREW 3/16-32 L=6.2	780-10824.3	1
36	切刀驱动杆锁紧板	LATCH	780-11031	1	74	螺钉11/64-40, L=18	SCREW 11/64-40 L=18	780A-11063A	2
37	螺钉1/4-24, L=9.5	SCREW 1/4-24, L=9.5	780-11032	1	75	螺钉15/64-28, L=8	SCREW 15/64-28 L=8	185-5/31-1067060	1
38	切刀驱动杆	KNIFE BAR DRIVING CRANK	780-11033	1	76	螺钉15/64-28, L=15	SCREW 15/64-28 L=15	780A-11065A	1

11. 送布凸轮及离合器部件 FEED CAM & TRIPPING SEGMENT COMPONENTS

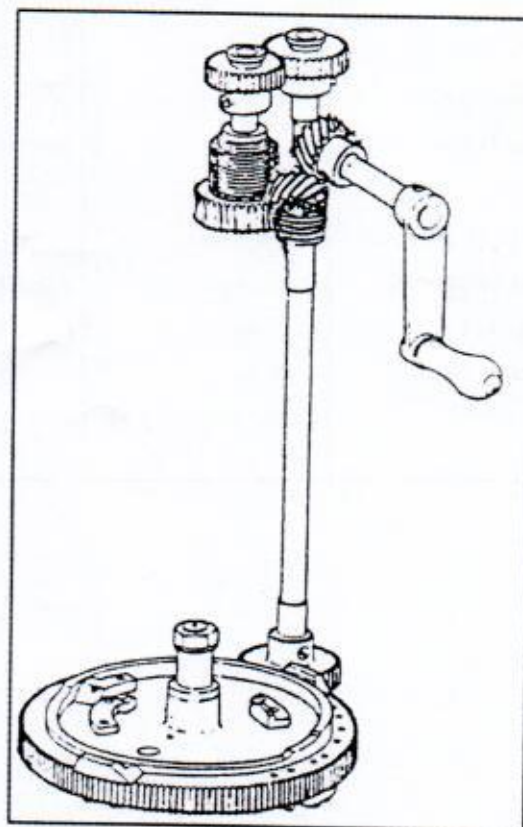
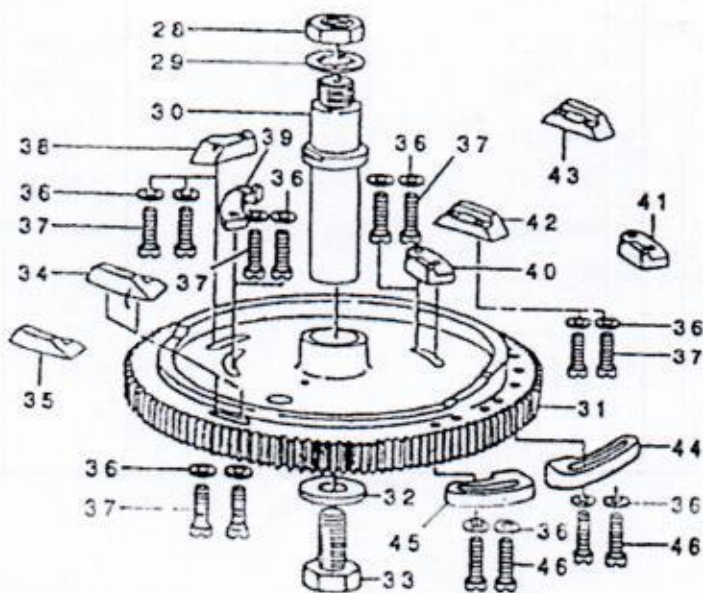
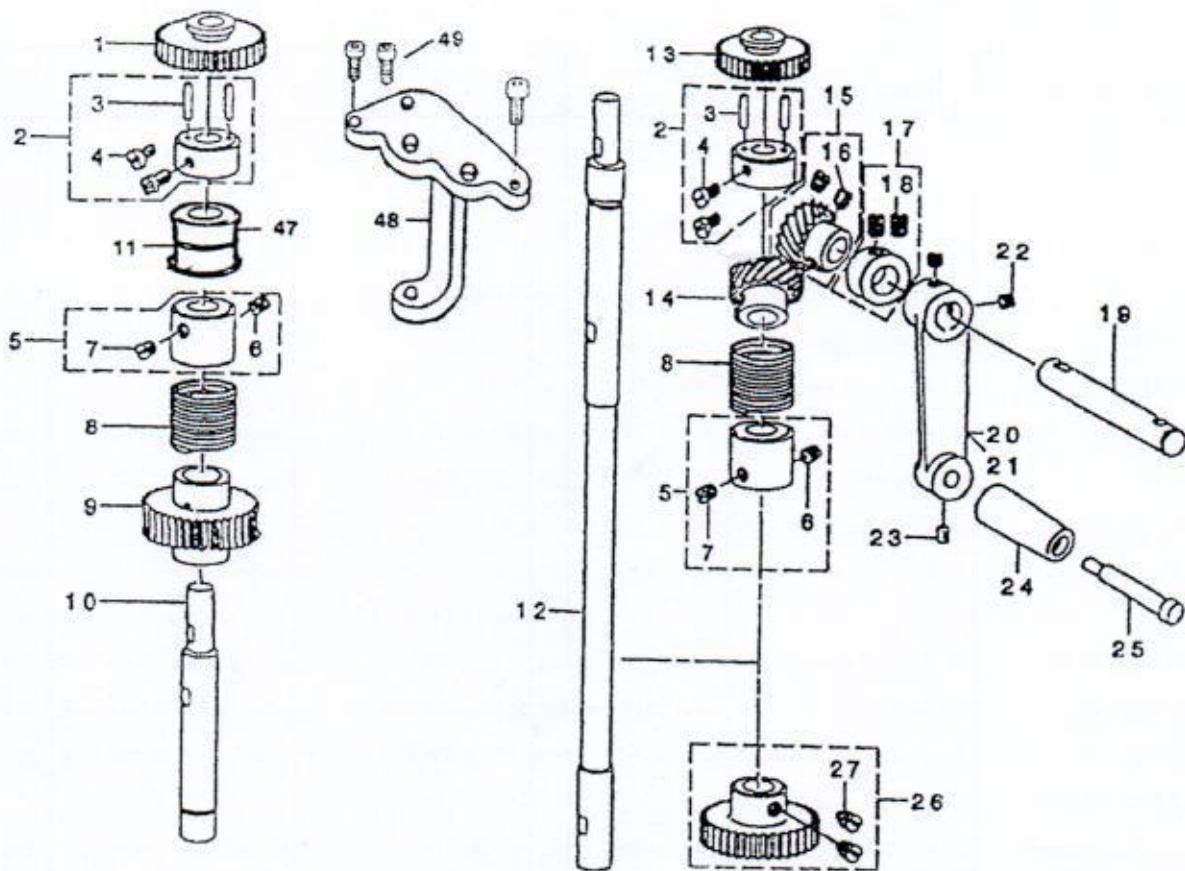

11. 送布凸轮及离合器部件 FEED CAM & TRIPPING SEGMENT COMPONENTS

序号	零件名称	Description	制造件号 (标准件规格)	数量	序号	零件名称	Description	制造件号 (标准件规格)	数量
1	针数变换齿轮	SPUR GEAR (152)	780-11128	1	27	螺钉15/64-28, L=6.5	SCREW 15/64-28 L=6.5	8-53-185	2
2	针数变换齿轮座	SPUR GEAR BUSHING ASM	780-11101	2	28	螺母M12×1.25	NUT M12	780-11132	1
3	针数变换齿轮定位销	SPUR GEAR BUSHING PIN	780-11102	4	29	送料凸轮止推垫圈	THRUST WASHER	780-11121	1
4	无头内六角螺钉3/16-28 L=6	SCREW 3/16-28 L=6	780A-11103	4	30	送料凸轮轴	FEED CAM SHAFT	780-11122	1
5	离合紧圈	CLUTCH COLLAR ASM	780A-11104	2	31	送料凸轮	FEED CAM	780-11123	1
6	螺钉15/64-28, L=5	SCREW 15/64-28 L=5	780A-11105	2	32	垫圈	WASHER 9.8×24.0×2.6	780-11124	1
7	螺钉15/64-28, L=5	SCREW 15/64-28 L=5	780A-11105	2	33	螺钉3/8-18, L=15	SCREW 3/8-18 L=15	780-11125	1
8	离合弹簧	CLUTCH SPRING	780-11106	2	34	加固离合块	BAR TRIPPING SEGMENT	780-11126	1
9	送料凸轮传动蜗轮	FEED CAM DRIVING WORM WHEEL	780A-11107	1					
10	传动蜗轮轴	FEED CAM DRIVING WORM WHEEL SH	780A-11108	1	36	垫圈	WASHER 4.8×8.4×0.8	780-11002	14
11	油毡	OIL FELT	780-11109	1	37	螺钉11/64-40, L=16	SCREW 11/64-40 L=16	780-11128	10
12	送料凸轮传动轴	FEED CAM DRIVING SHAFT	780A-11110	1	38	切刀离合块	KNIFE TRIPPING SEGMENT	780-11129	1
13	针数变换齿轮	SPUR GEAR (123)	780-12127	1	39	加固松线离合块	TENSION RELEASE TRIPPING SEGME	780-11130	1
14	螺旋齿轮(下)	SPIRAL WHEEL GEAR (90°/90)	780A-11111	1	40	停车松线离合块	TENSION RELEASE TRIPPING SEGME	780-11131	1
15	螺旋齿轮(上)	SPIRAL WHEEL GEAR (70°)	780A-11112	1					
16	螺钉15/64-28, L=5	SCREW 15/64-28 L=5	780A-11105	2	42	加固离合块	BAR TRIPPING SEGMENT	780-11126	1
17	挡圈	THRUST COLLAR ASM D=11.11 W=1	780-11113	1					
18	螺钉1/4-40, L=4.5	SCREW 1/4-40 L=4.5	780-10333	2	44	低速凸轮块	LOW-SPEED CAM	780-11134	1
19	手动送料曲柄轴	HANDLE CRANK SHAFT	780A-11114	1	45	止动凸轮块	STOPPER CAM	780-11135	1
20	手动送料曲柄	HANDLE CRANK	780-11115	1	46	螺钉11/64-40, L=14	SCREW 11/64-40 L=14	780-10127	4
					47	固定套管	FASTNESS BUSHING	780A-11136	1
22	螺钉15/64-28, L=4.7	SCREW 15/64-28 L=4.7	780-11116	2	48	齿轮定位架	WHEEL GEAR FIXED POSITION	780A-11137	1
23	螺钉3/16-32, L=6	SCREW 3/16-32 L=6	780-11117	1	49	螺钉	SCREW 15/64-28 L=16	4-26-185	3
24	手动送料手柄	HANDLE SHAFT	780-11118	1					
25	手动送料手柄轴	HANDLE SHAFT	780-11119	1					
26	送料凸轮传动齿轮	FEED CAM DRIVING GEAR ASM	780A-11120	1					

12. 止动部件 STOP-MOTION COMPONENTS

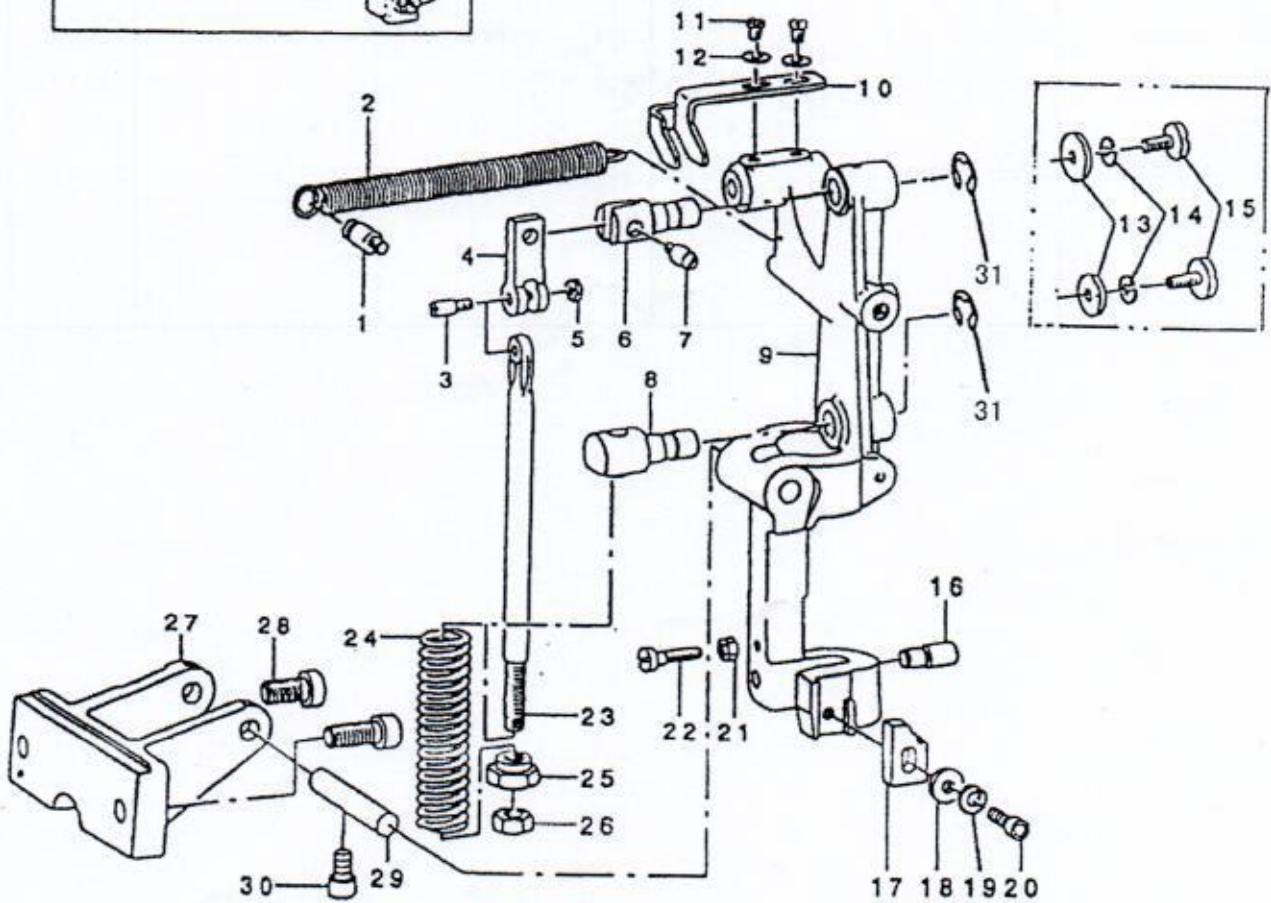
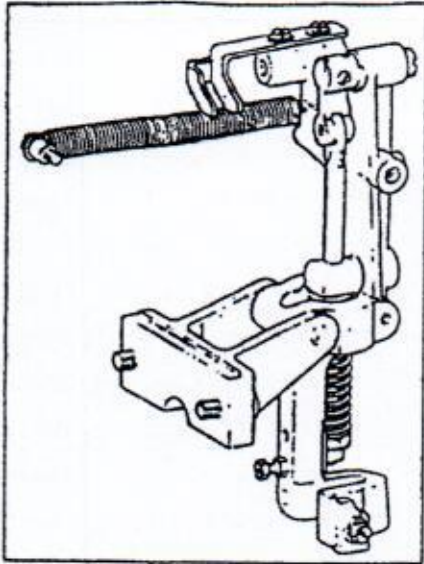

12. 止动部件 STOP-MOTION COMPONENTS

序号	零件名称	Description	制造件号 (标准件规格)	数量	序号	零件名称	Description	制造件号 (标准件规格)	数量
1	拉簧悬挂螺钉	SUSPENSION SCREW(A)	780-11201	1	17	止动分档块	LATCH, A	780-11215	1
2	拉簧	TENSION SPRING	780-11202	1	18	垫圈6.1×15.2×2.5	WASHER 6.1×15.2×2.5	GB97-76	1
3	止动连杆铰链销螺钉	STOP LINK ROD HINGE SCREW	780-11203	1	19	弹簧垫圈6	WASHER	GB93-76	1
4	止动铰接板	STOP LINK	780-11204	1	20	圆柱内六角螺钉6×20	SCREW M6 1-20	GB70-76	1
5	螺母3/16-32	NUT 3/16-32	780-11205	1	21	螺母15/64-28	NUT 15/64-28	780-11217	1
6	止动连杆上接头	STOP LINK HINGE STUD	780-10206	1	22	螺钉15/64-28, L=30	SCREW 15/64-28 L=30	780-11218	1
7	止动铰接板连接螺钉	STOP LINK CONNECTING SCREW	780-11207	1	23	止动缓冲连杆	STOP LINK ROD	780-11219	1
8	止动连杆下接头	STOP LINK ROD HINGE STUD	780-11208	1	24	止动缓冲连杆压簧	STOP LINK ROD PRESSURE SPRING	780-11220	1
9	止动连杆	STOP MOTION LEVER	780A-11209	1	25	压簧调节螺母	NUT FOR STOP LINK ROD	780-11221	1
10	上轴皮带拨叉	BELT SHIFTER	780-11210	1	26	压簧锁紧螺母	NUT 3/8-18	780-11222	1
11	螺钉15/64-28, L=7	SCREW 15/64-28 L=7	780-10808	2	27	止动连杆座	STOP MOTION LEVER BRACKET	780-11223	1
12	垫圈6.5×13×0.8	WASHER 6.5×13×0.8	780-11211	2	28	圆柱内六角螺钉10×20	SCREW M10 1-20	GB70-76	2
13	垫圈6.1×18.5×2	WASHER 6.1×18.5×2	780-11212	2	29	止动连杆销	PIN	780-11224	1
14	弹簧垫圈6	WASHER	GB93-76	2	30	圆柱内六角螺钉6×16	SCREW M6 1-16	GB70-76	1
15	螺钉15/64-28, L=13	SCREW 15/64-28 L=13.0	780-11213	2	31	轴用挡圈φ11	RETAINING RING φ11	GB894-76	1
16	起动顶杆	STOP PIN	780-11214	1					

13. 运转脱离部件 TRIPPING LEVER COMPONENTS

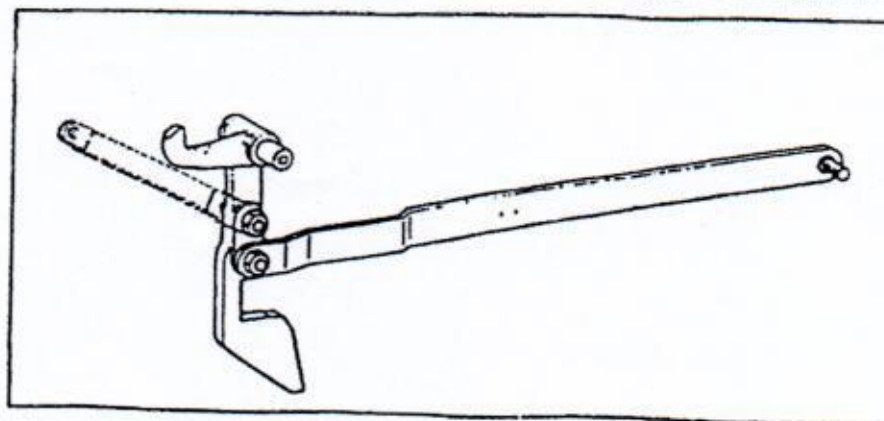
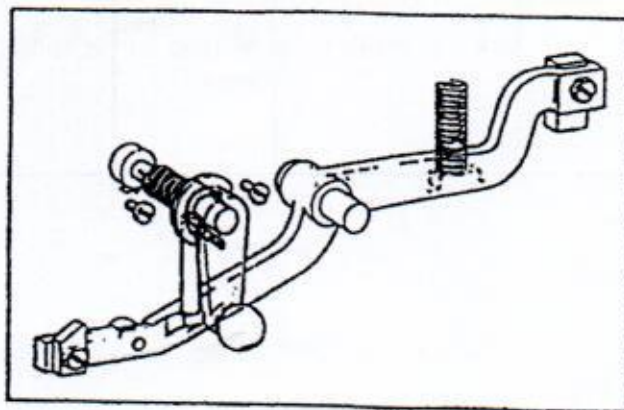
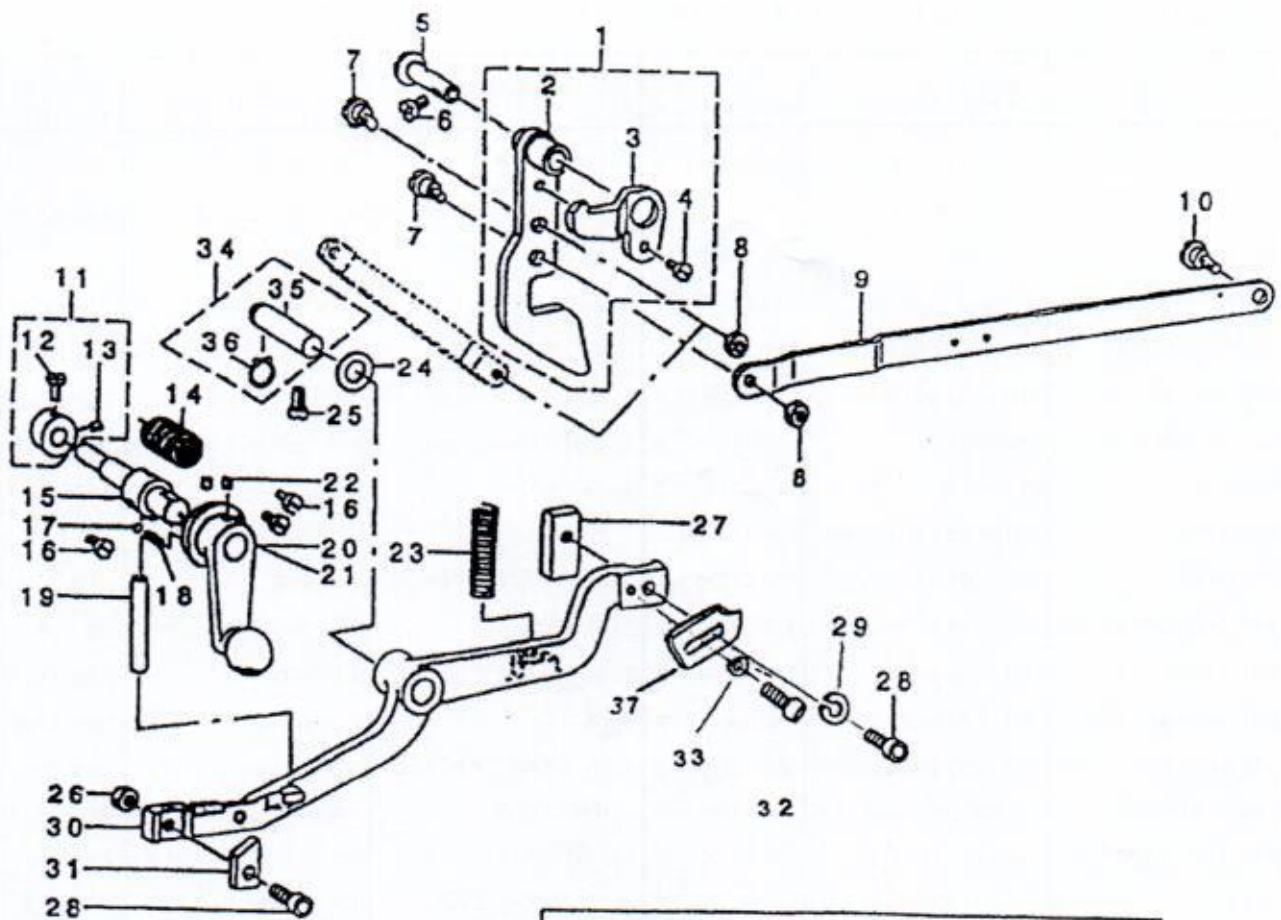

13. 运转脱离部件 TRIPPING LEVER COMPONENTS

序号	零件名称	Description	制造件号 (标准件规格)	数量	序号	零件名称	Description	制造件号 (标准件规格)	数量
1	起动架组件	STARTING LINK ASM	780-11301A	1	19	手制动顶轴	HAND STOP ROD	780-11311	1
2	起动架	STARTING LINK COMPL	780-11301B	1	20	手柄	HAND STOP CRANK ASM	780-11312	1
3	安全钩	SAFETY BASE	780-11302	1					
4	螺钉11/64-40, L=7	SCREW 11/64-40 L=7	780-10140	1	22	螺钉15/64-8, L=4.7	SCREW 15/64-28 L=4.7	780-11116	2
5	起动架组件铰链销	HINGE STUD	780-10940	1	23	运转脱离杆压簧	TRIPPING LEVER TENSION SPRING	780-11313	1
6	螺钉15/64-28, L=9	SCREW 15/64-28 L=9	780-10721	1	24	垫圈	WASHER	780-11314	1
7	偏心铰链销螺钉	HINGE SCREW	780-11304	2	25	螺钉15/64-28, L=9	SCREW 15/64-28 L=9	780-10721	1
8	螺母15/64-28	NUT 15/64-28	780-10544	2	26	螺母M6	NUT M6	GB/T6170-1986	1
9	起动架拉杆	STARTING LINK DRIVING ROD	780-11305	1	27	锁定板	LATCH (B)	780-11315	1
10	铰链销螺钉	HINGE SCREW D=7.94 H=4.5	780-11306	1	28	内六角螺钉 M=6, L=22	SCREW M6 L=22	GB70-76	1
11	手制动曲柄轴挡圈	THRUST COLLAR ASM D=7.94 W=10	780-11307	1	29	弹簧垫圈	SPRING WASHER 6.5×12.5×1.5	GB93-76	1
12	螺钉11/64-40, L=7	SCREW 11/64-40 L=7	780-10140	1	30	运转脱离杆	TRIPPING LEVER	780A-11317	1
13	螺钉11/64-40, L=5	SCREW 11/64-40 L=5	780-10111	1	31	脱离爪	TRIPPING DOG	780-11318	1
14	曲柄轴转矩弹簧	CRANK SHAFT TENSION SPRING	780-11308	1	32	内六角螺钉 M=5, L=12	SCREW M5 L=12	GB70-76	1
15	手制动曲柄轴	HAND STOP CRANK SHAFT	780-11309	1	33	弹簧垫圈φ5	WASHER φ5	GB93-76	1
16	螺钉11/64-40, L=9.5	SCREW 11/64-40 L=9.5	780-10536	2	34	铰链销组件	TRIPPING LEVER HINGE PIN ASM	780-11321	1
17	钢球4	HAND STOP CRANK SHAFT BALL	GB308-77	1	35	运转脱离杆铰链销	TRIPPING LEVER HINGE PIN	780-11322	1
18	曲柄压簧	CRANK SHAFT PRESSURE SPRING	780-11310	1	36	轴用弹性挡圈φ11	RETAINING RING φ11	GB894-76	1
					37	起动块	STARTING PIECE	780A-11323	1

14. 压脚提升架和绕线器部件 LIFTING LEVER & BOBBIN WINDER COMPONENTS

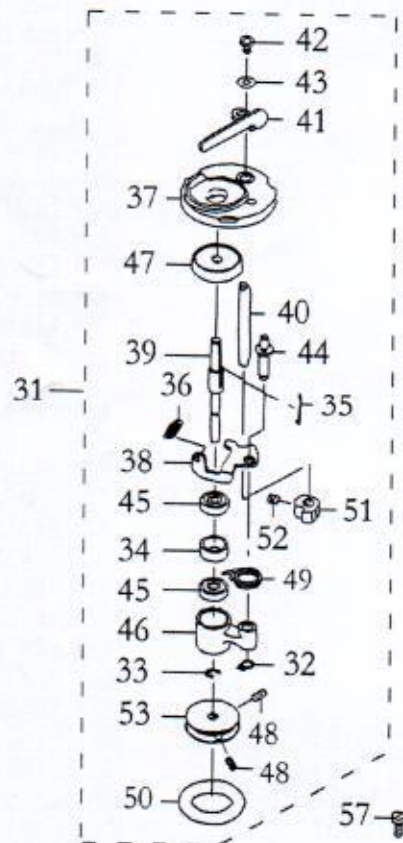
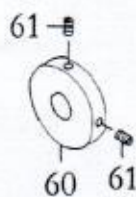
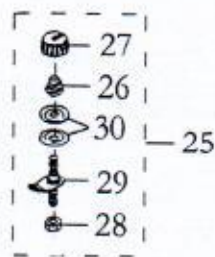
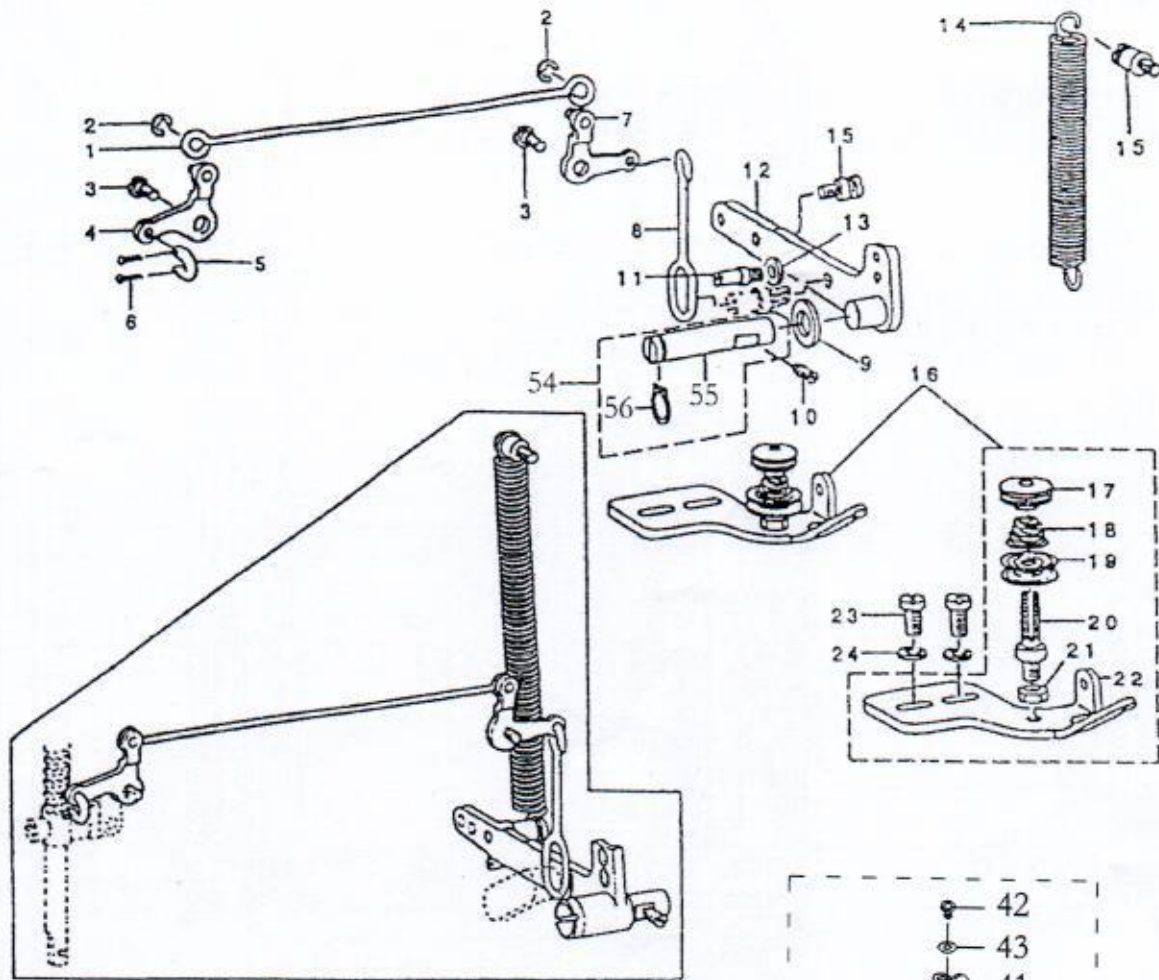

14. 压脚提升架和绕线器部件 LIFTING LEVER & BOBBIN WINDER COMPONENTS

序号	零件名称	Description	制造件号	数量
1	压脚提升长拉杆	PRESSER BAR LIFTING ROD LONG	780-11401	1
2	开口挡圈5	E-RING	GB896-76	2
3	杠杆铰链销螺钉	HINGE SCREW D=7.24 H=3.3	780-11402	2
4	压脚提升前杠杆	LEVER ASM FRONT	780A-11403	1
5	前杠杆连接环	LINK	780-11404	1
6	开口销2×10	SPLIT PIN	GB91-76	2
7	压脚提升后杠杆组件	LEVER ASM REAR	780-11405	1
8	压脚提升拉杆	PRESSER BAR LIFTING ROD	780-11406	1
9	垫圈	WASHER	780-11314	1
10	螺钉15/64-28, L=10.5	SCREW 15/64-28 L=10.5	780-10302	1
11	压棒提升限位螺钉	LIFTING LEVER STOPPER	780-11407	1
12	压棒提升杆	PRESSER BAR LIFTING LEVER ASM	780-11408	1
13	垫圈	WASHER 7.4×11.8×0.5	780-11409	1
14	压脚提升拉杆簧	PRESSER FOOT LIFTING SPRING	780-11410	1
15	拉簧悬挂螺钉	SUSPENSION SCREW(A)	780-11201	1
16	绕线器过线组件	BOBBIN WINDER TENSING ASM	780-11412	1
17	夹线螺母	BOBBIN WINDER TENSION NUT	780-11413	1
18	绕梭心线夹线弹簧	BOBBIN WINDER TENSION SPRING	780-11414	1
19	夹线盘	BOBBIN WINDER TENSION DISC	780-11415	2
20	绕梭心线过线螺钉	BOBBIN WINDER TENSION POST	780-11416	1
21	螺母11/64-40	NUT 11/64-40	780-10211	1
22	绕梭心线过线架	BOBBIN WINDER TENSION BRACKET	780-11417	1
23	螺钉11/64-40, L=7.8	SCREW 11/64-40 L=7.8	780-10516	2
24	垫圈4.8×11.5×2	WASHER 4.8×11.5×2	780-11418	2
25	绕线器组件	BOBBIN THREAD TENSION ASM.	01-74-1900	1
26	压线弹簧	CONNECTING ROD SPRING	11414-780	1
27	夹线螺母	THREAD TENSION NUT	11413-780	1
28	螺母11/64-40	NUT 11/64-40	10211-780	1
29	绕线器过线螺钉	BOBBIN THREAD TENSION ROD ASM.	11416-780	1
30	夹线盘	THREAD TENSION DISK	11415-780	2
31		BOBBIN WINDER UNIT		1
32		RETAINING RING		(1)
33		E-RING 4		(1)
34		BTW BEARING SPACER		(1)
35		BOBBIN SPRING		(1)
36		BTW SPRING		(1)
37		BTW BASE		(1)
38		BTW CAM PLATE		(1)
39		BTW SHAFT		(1)
40		BTW LEVER SHAFT		(1)
41		BTW LEVER		(1)
42	绕线器组件	SCREW	14-31-791	(1)
43		WASHER 4.5X10X0.8		(1)
44		BTW BASE SHAFT		(1)
45		BTW BEARING		(2)
46		BTW SHAFT BASE		(1)
47		BTW SPACER		(1)
48		SCREW M4X8		(2)
49		BTW TORSION SPRING		(1)
50		BTW WHEEL RUBBER		(1)
51		BTW CAM LEVER		(1)
52		SCREW M5 L=5		(1)
53		BTW WHEEL		(1)
54	离合杆铰链销组件	TRIPPING LEVER HINGE PIN ASM	780-11321	1
55	离合杆铰链销	TRIPPING LEVER HINGE PIN	780-11322	1
56	轴用弹性挡圈φ11	RETAINING RING 10.2	GB894-76	1
57	螺钉 M4 L=11	SCREW M4 L=11	02-27-210	3
58	螺钉M3 L=6	SCREW M3 X 6	GB	2
59	断线刀片	THREAD CUTTER	01-047-1900	1
60	摩擦轮		21-791	1
61	螺钉 SM11/64-40	SCREW 11/64-40 L=4.5	05-30-119	2

15. 夹线器部件 THREAD TENSION COMPONENTS

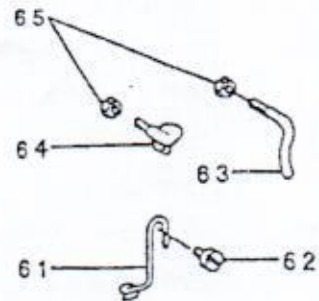
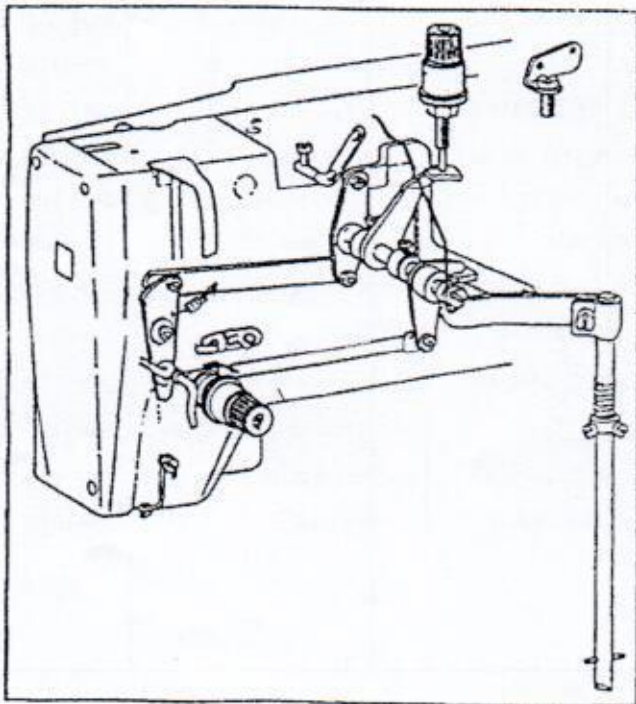
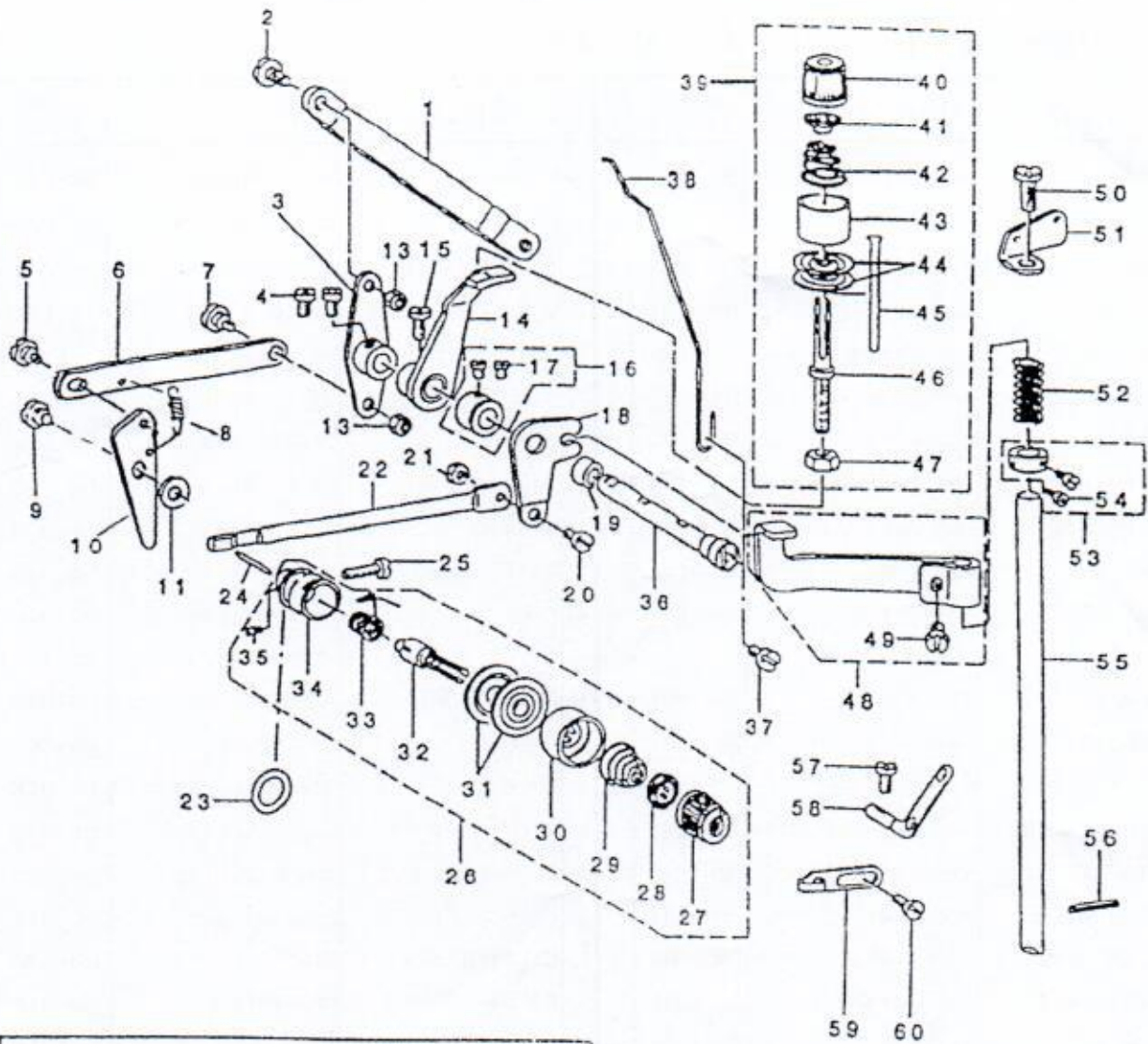

15. 夹线器部件 THREAD TENSION COMPONENTS

序号	零件名称	Description	制造件号 (标准件规格)	数量	序号	零件名称	Description	制造件号 (标准件规格)	数量
1	松线拉杆	TENSION RELEASE LINK	780-11501	1	34	过线螺钉座	TENSION POST SOCKET	780-11527	1
2	铰链销螺钉	HINGE SCREW D=6.35 H=3.9	780-11502	1	35	螺钉9/64-40, L=5.5	SCREW 9/64-40 L=5.5	780-11528	1
3	松线杠杆	TENSION RELEASE LEVER	780-11503	1	36	加固松线杆曲柄轴	TENSION RELEASE LEVER SHAFT	780-11529	1
4	螺钉1/4-40, L=7	SCREW 1/4-40 L=7.0	780-10414	2	37	螺钉11/64-40, L=7.8	SCREW 11/64-40 L=7.8	780-11516	1
5	安全推杆轴位螺钉	HINGE SCREW D=6.35 H=2.4	780A-11504	1	38	拔线钢丝	THREAD PULLING WIRE	780A-11530	1
6	安全推杆	BLOCKING LINK	780A-11505	1	39	夹线控制器1号组件	TENSION CONTROLLER NO.1 ASM	780-11531	1
7	铰链销螺钉	HINGE SCREW D=6.35 H=3.9	780-11502	1	40	夹线螺母	THREAD TENSION PICK-UP (RED)	780-11520	1
8	安全推杆拉簧	BLOCKING ARM SPRING	780A-11507	1	41	夹线螺母定位板	TENSION SPRING BUSHING	780-11521	1
9	安全拔杆轴位螺钉	HINGE SCREW D=7.94 H=3.1	780A-11508	1	42	压线弹簧	TENSION SPRING NO.1	780-11532	1
10	安全拔杆	BLOCKING ARM	780A-11509	1	43	管状夹线板压夹线盘	THREAD TENSION DISK PRESSER	780-11523	1
11	安全拔杆垫圈	BLOCKING ARM BRACKET	780A-11510	1	44	夹线盘	THREAD TENSION DISK	780-11524	2
					45	松线销	TENSION RELEASE PIN NO.2	780A-11533	1
13	螺母3/16-28	NUT 3/16-28	780-10928	2	46	面线第一过线钉	TENSION POST NO.2	780-11534	1
14	止动松线顶杆	TENSION RELEASE LEVER	780-11511	1	47	螺母1/4-24	NUT 1/4-24	780-10613	1
15	螺钉	SCREW 3/16-32 L=9.5	780-11512	1	48	松线臂	TENSION RELEASE ARM ASM	780-11535	1
16	加固松线杆曲柄紧固	THRUST COLLAR ASM D=7.94 W=10	780-11307	1	49	螺钉1/4-40, L=8.5	SCREW 1/4-40 L=8.5	780-11536	1
17	螺钉11/64-40, L=7	SCREW 11/64-40 L=7	780-11140	2	50	螺钉15/64-28, L=12	SCREW 15/64-28 L=12	780-10610	1
18	加固松线杆曲柄	TENSION RELEASE CRANK NO.2	780-11514	1	51	导线板	THREAD GUIDE PLATE	780-11537	1
19	松线杆曲柄轴轴套	TENSION RELEASE LEVER COLLAR N	780-11515	1	52	松线顶杆复位弹簧	SPRING	780-11538	1
20	松线杆铰链销螺钉	HINGE SCREW D=5 H=3	780-11516	1	53	止推紧固	THRUST COLLAR ASM	780-11539	1
21	螺母9/64-40	NUT 9/64-40	780-10406	1	54	螺钉9/64-40, L=4.5	SCREW 9/64-40 L=4.5	780-10628	2
22	加固松线杆	TENSION RELEASE ROD	780-11517	1	55	松线顶杆	TENSION RELEASE ROD	780-11540	1
23	O型密封圈14×1.9	RUBBER RING	GB1235-76	1	56	弹性圆柱销3×20	SPRING PIN 3×18	GB879-76	1
24	松线钉	TENSION RELEASE PIN NO.2	780A-11518	1	57	螺钉11/64-40, L=7	SCREW 11/64-40 L=7	780-11140	1
25	螺钉11/64-40, L=16	SCREW 11/64-40 L=16	780-11128	1	58	二眼线钩	THREAD EYELET	780-11541	1
26	夹线控制器2号组件	TENSION CONTROLLER NO.2 ASM	780-11519	1	59	右线钩	ARM THREAD GUIDE A	780-11542	1
27	夹线螺母	THREAD TENSION PICK-UP (RED)	780-11520	1	60	螺钉9/64-40, L=6.8	SCREW 9/64-40 L=6.8	780-10512	1
28	夹线螺母定位板	TENSION SPRING BUSHING	780-11521	1	61	针杆过线钩	NEEDLE BAR THREAD GUIDE	780-11543	1
29	压线弹簧	TENSION SPRING RED	780-11522	1	62	螺钉11/64-40, L=7.8	SCREW 11/64-40 L=7.8	780-10516	1
30	管状夹线板压板	THREAD TENSION DISK PRESSER	780-11523	1	63	紧线钩	TENSION THREAD GUIDE NO.2	780-11544	1
31	夹线盘	THREAD TENSION DISK	780-10524	2	64	挑线过线勾	THREAD GUIDE	780A-11545	1
32	面线第二过线螺钉	TENSION POST NO.3	780-11525	1	65	螺母9/64-40	NUT 9/64-40	780-10406	2
33	挑线弹簧	THREAD TAKE-UP SPRING	780-11526	1					

16. 润滑机构部件 LUBRICATION MECHANISM COMPONENTS

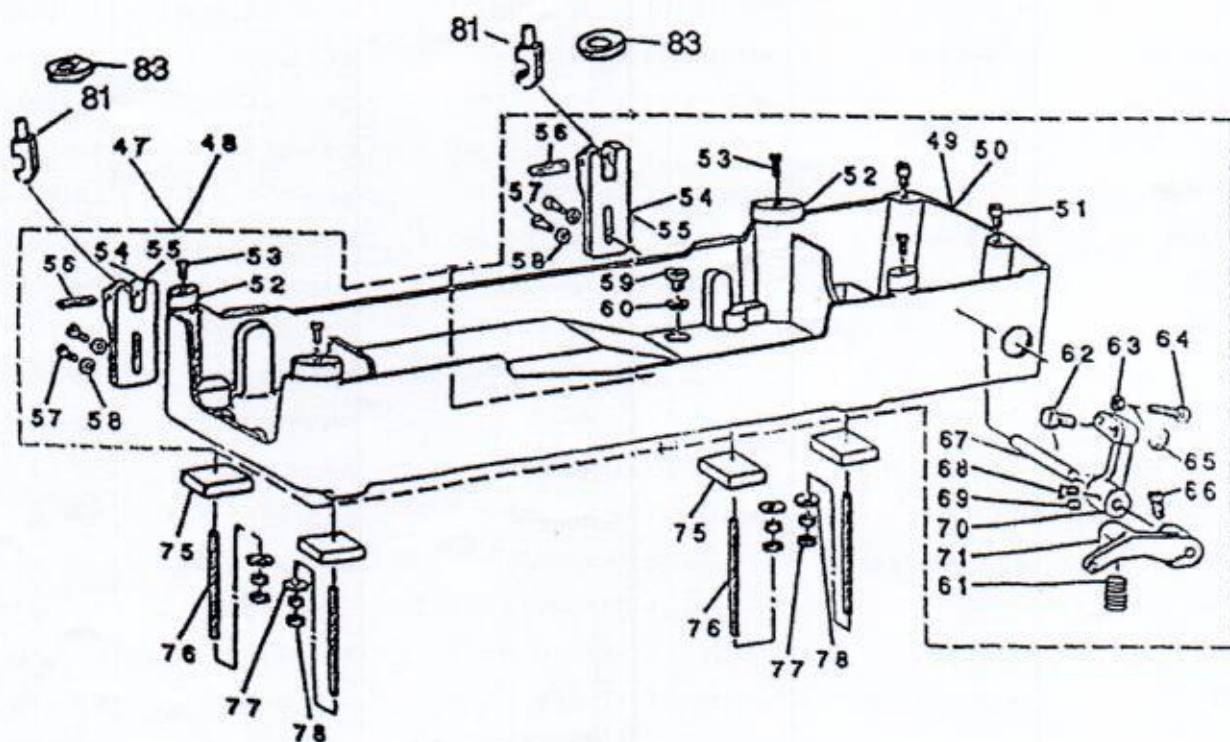
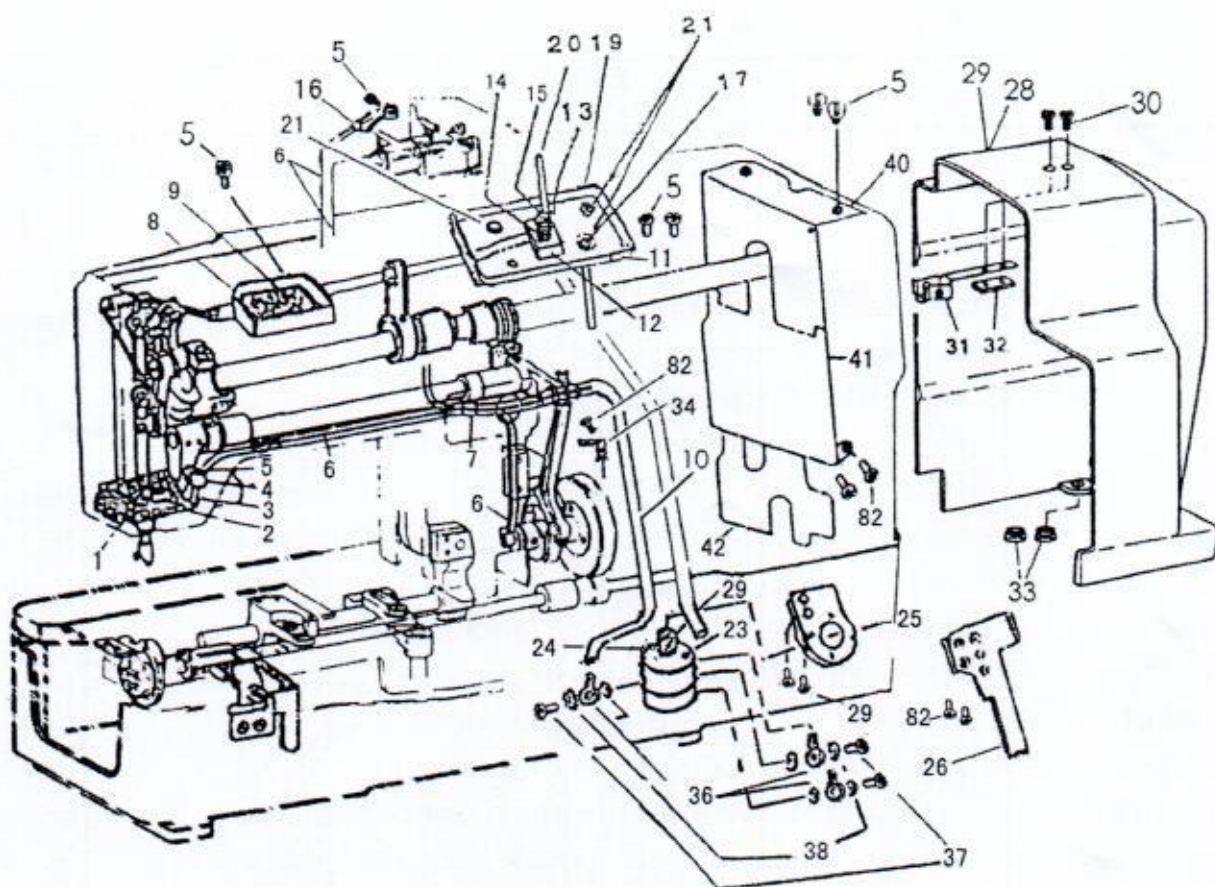

16. 润滑机构部件 LUBRICATION MECHANISM COMPONENTS

序号	零件名称	Description	制造件号 (标准件规格)	数量	序号	零件名称	Description	制造件号 (标准件规格)	数量
1	油毡压簧	OIL FELT PRESSURE SPRING	780A-11601	1	37	油管接头螺钉	VINYL PIPE CONNECTING SCREW	780A-11649	3
2	回油毡	OIL RETURN FELT (A)	780A-11602	1	38	红番柏垫圈 $\phi 6.5 \times \phi 10.5 \times 1$	WASHER $\phi 6.5 \times \phi 10.5 \times 1$	标准件	6
3	回油管	OIL RETURN TUBE	780-11603	1	40	上油罩	OIL COVER (TOP)	780A-11630	1
4	油管压板	CABLE HOLDER	780A-11604	1	41	中油罩	OIL COVER (MIDDLE)	780A-11631	1
5	螺钉11/64-40 L=7	SCREW 11/64-40 L=7	780-10140	6	42	下油罩	OIL COVER (BOTTOM)	780A-11632	1
6	回油毡	OIL RETURN FELT	780-11605	1					
7	油芯	OIL WICK	780A-11606	1					
8	储油器	FOUNT	780A-11607	1	47	底座组件	MACHINE BASE ASM	780-11636	1
9	油毡	OIL FELT	780A-11608	1	49	油池	OIL RESERVOIR	780-11637	1
10	油管	VINYL PIPE	780A-11609	1	51	皮带罩定位螺钉	GUIDE PIN	780-11638	2
11	盛油盘组件	OIL RECEIVER ASM	780A-11610	1	52	机头橡胶座垫	RUBBER CUSHION	780-11639	4
12	调节润滑螺钉座	OIL ADJUSTING SCREW BASE	780A-11611	1	53	螺钉11/64-40, L=10.5	SCREW 11/64-40 L=10.5	780-10338	4
13	调节润滑螺钉	OIL ADJUSTING SCREW	780A-11612	1	54	机头铰链座	HINGE HOLDER	780-11640	2
14	油量调节弹簧	OIL ADJUSTING SPRING	780A-11613	1	56	弹性圆柱销	PIN	GB879-76	2
15	油量调节开关	OIL ADJUSTING SWITCH	780A-11614	1	57	圆柱内六角螺钉6×20	SCREW M6 L=20	GB70-76	4
					58	垫圈M6	WASHER M6	GB93-76	4
17	引油管	VINYL PIPE	780A-11615	1	59	螺钉	SCREW	780-11643	1
					60	密封垫	OIL DRAIN CAP GASKET	780-11644	1
19	油毡	OIL FELT	780A-11616	1	61	起动机杆压簧	STARTING LEVER PRESSURE SPRING	780-11645	1
20	示油窗标油螺钉	OIL MARK SCREW	780A-11617	1	62	调节螺钉M8	SCREW M8 L=20	780-10733	1
21	螺母1/4	NUT 1/4	780-11013	4	63	螺母15/64-28	NUT 15/64-28	780-10544	1
					64	起动机架限位螺钉	STOP SCREW ASM	780-11646	1
23	油泵完全座	OIL PUMP	780A-11619	1	65	螺母M8	NUT M8	GB/T6175-1986	1
24	润滑泵蜗轮	OIL PUMP WORM GEAR	780A-11620	1	66	螺钉15/64-28, L=12	SCREW 15/64-28 L=12	780-10610	1
25	油泵板	OIL PUMP PLANK	780A-11621	1	67	起动机架轴	STARTING LINK SHAFT	780A-11647	1
26	油管导板	VINYL PIPE PLANK	780A-11622	1	68	起动机架定位螺钉	SCREW	780-11648	1
					69	螺钉15/64-28, L=7	SCREW 15/64-28 L=7	780-10323	1
28	皮带罩	BELT GUARD	780-11623	1	70	起动机架	STARTING LINK	780-11649	1
29	螺钉11/64-40, L=12	SCREW 11/64-40 L=12	780-10107	2	71	起动机杆	STARTING LEVER	780-11650	1
30	螺钉11/64-40, L=8.5	SCREW 11/64-40 L=8.5	780-11624	2	75	底座毡垫	MACHINE BASE FELT PAD	780-11653	4
31	皮带罩安装夹	BELT GUARD SET SCREW	780-11625	1	76	底座螺栓	MACHINE BASE SCREW STUD	780-11654	4
32	底部导板	BOTTOM GUIDE	780-11626	1	77	垫圈6.1×18.5×2	WASHER 6.1×18.5×2	780-11655	4
33	橡胶轴套	RUBBER BUSHING	780-11627	2	78	螺母15/64-28	NUT 15/64-28	780-10544	4
34	油管固定夹	VINYL PIPE FIX LATCH	780A-11657	1	81	连接销	CONNECTION STUD	780-11658	2
					82	螺钉9/64-40 L=6.8	SCREW 9/64-40 L=6.8	780-10512	7
36	油管接头	VINYL PIPE CONNECTING	780A-11648	3	83	橡胶垫圈	RUBBER WASHER	780-11660	2

电器控制部分 ELECTRICAL CONTROL COMPONENTS

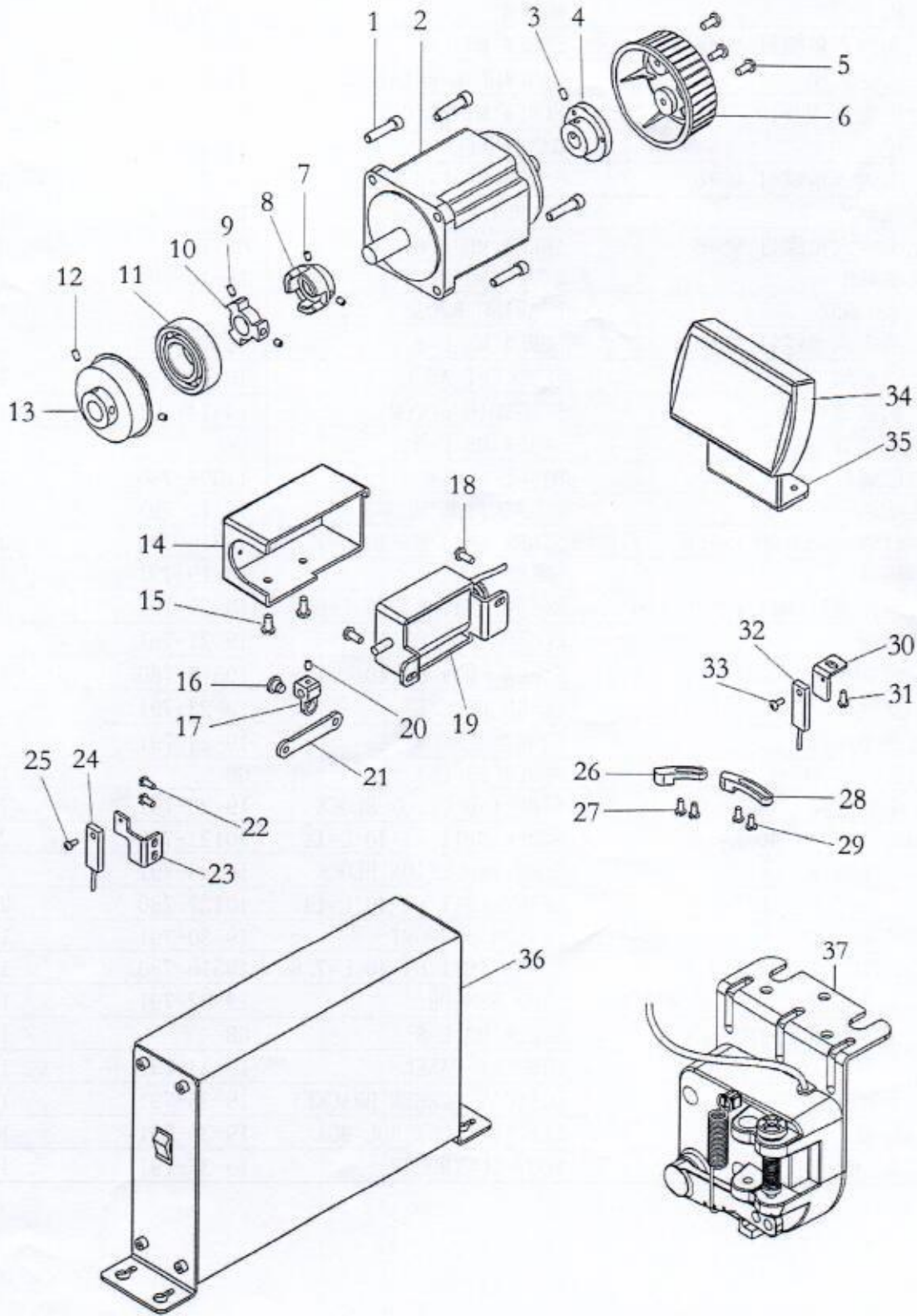

电器控制部分 ELECTRICAL CONTROL COMPONENTS

序号	零部件名称	DESCRIPTION	件号	数量
1	内六角螺钉 M5*30	SCREW M5 L=30	GB70	4
2	电机	MOTOR	19-02-791	1
3	无头内六角螺钉 M5*6	SCREW M5 L=6	GB77	2
4	手轮安装座	HANDWHEEL RETAINER	19-04-791	1
5	盘头螺钉 M4*10	SCREW M4 L=10	GB	3
6	手轮	HANDWHEEL	19-06-791	1
7	无头内六角螺钉 M6*6	SCREW M6 L=6	GB77	3
8	联轴器A	COUPLING A	19-08-791	1
9	无头内六角螺钉 M6*6	SCREW M6 L=6	GB77	3
10	联轴器B	COUPLING B	19-10-791	1
11	轴承6205Z	BEARING 6205Z	GB	1
12	无头内六角螺钉 M5*6	SCREW M5 L=6	GB77	2
13	上轴带轮	SPROCKET WHEEL	19-13-791	1
14	电磁铁罩壳	SOLENOID COVER	19-14-791	1
15	盘头螺钉 M5*6	SCREW M5 L=6	GB	2
16	轴位螺钉	HINGE SEREW	11306-780	2
17	连接块	CONNECTION BLOCK	19-17-791	1
18	螺钉SM11/64-40 L=7.8	SCREW SM11/64-40 L=7.8	10516-780	2
19	电磁铁	SOLENOID	19-19-791	1
20	内六角螺钉SM11/64-40 L=6	SCREW SM11/64-40 L=6	19-20-791	2
21	连接板	CONNECTION PLATE	19-21-791	1
22	螺钉SM11/64-40 L=7.8	SCREW SM11/64-40 L=7.8	10516-780	2
23	小支架	SMALL BRACKET	19-23-791	1
24	启动感应器	START SENSOR	19-24-791	1
25	盘头螺钉 M3*4	SCREW M3 L=4	GB	1
26	停车感应座	STOP INDUCTION BLOCK	19-26-791	1
27	螺钉SM11/64-40 L=14	SCREW SM11/64-40 L=14	10127-780	2
28	慢速感应座	SLOW INDUCTION BLOCK	19-28-791	1
29	螺钉SM11/64-40 L=14	SCREW SM11/64-40 L=14	10127-780	2
30	感应器支架	SENSOR SUPPORT	19-30-791	1
31	螺钉SM11/64-40 L=7.8	SCREW SM11/64-40 L=7.8	10516-780	1
32	停车感应器	STOP SENSOR	19-32-791	1
33	不锈钢盘头螺钉M3*8	SCREW M3 L=8	GB	1
34	显示屏	DISPLAY PANEL	19-34-791	1
35	显示屏支架	DISPLAY SCREEN BRACKET	19-35-791	1
36	电控箱	ELECTRIC CONTROL BOX	19-36-791	1
37	脚踏控制器	FOOT CONTROLER	19-37-791	1