

GLOBAL

BT 13060 H - TB

PARTS / INSTRUCTION MANUAL



Contents

I. Brief instruction	3
II. Features	3
III. Main specifications	3
IV. Operation instruction	3
V. Machine adjustment	4
VI. Winding the bobbin thread	6
VII. Threading the needle thread	7
VIII. Plan view of the complete machine	8
IX. Outside connection of the control box	9
X. Parts cataloge	10
1、 Machine hell parts	10
2、 Arm shaftand thread take-up	12
3、 Needle bar and presser bar	14
4、 Lower shaftand pendulum shaft	16
5、 Presser foot lipt timing	18
6、 Horixontal transmission	20
7、 vertical transmission	22
8、 Thread tension	24
9、 Built-in bobbinwinde	26
10、 Table topand stand	28
XI. Control Box Operation Instruction	30
1 Control box hardware specifications.....	30
1.1 Power specification.....	30
1.2 Replace the fuse.....	30
1.3 X/Y origin detector	30
1.4 Motors installation	30
1.5 Inner structure of the Control Box	31
2 Operation of the Sewing Machine	32
2.1 Keys Description.....	32
2.2 Adjusting zero position.....	34
2.2.1 Adjusting the position of the induction rion for the sensor of the needle upper position...34	
2.3 Basic operation.....	35
2.4 Transferring patterns by a USB disk	38
2.5 Adjusting system parameters	39
3 Pattern Inputing.....	40
3.1 Create a new pattern.....	40
3.2 Modify an existing pattern	47
3.3 Input select key	48
3.4 Pattern input key	49
3.5 Section moving, rotation and copy	50
3.6 Pattern for non-stitch feeding.....	51
3.7 Inserting stitch quickly.....	52
3.8 Translation of the pattern/Change pattern center (F1)	53
3.9 Re-Curve (F2)	

3.10	Inputting symmetrical pattern	54
3.11	Modification of the feed pitch.....	54
3.12	Drawing repeat design	55
3.13	Deleting pattern.....	56
4	Download patterns from PC.....	56
5	Maintainance of IO Devices	59
5.1	Input devices check.....	59
5.2	Output devices check	59
6	Appendix.....	61
	Appendix 1. System parameter list	61
	Appendix 2. Trouble Indication Table	65

Accessories:

1、Accessories of the machine head

1	Thead stand	1Set	7	Hexagon apanner	1Set	13	ScrewM5X12	9Pcs
2	Hinge	2Sets	8	Oil can	1Pc	14	Nut M5	9Pcs
3	Rubber wasger	4Pcs	9	Needle	5Pcs	15	Screw St3X10	6Pcs
4	Oil pan	1Pc	10	Bobbin	5Pcs	16	Silicon oil box	1Pc
5	Big screw driver	1Pc	11	Rubber ring	3Pcs	17		
6	Smsll screw dvtrer	2Pcs	12	Foot pedal support	1Pc	18		

2、Accessories of control box

1	Operation box	1PC	7	Hexagon apanner	1Set	13	Screw St6.3X30	4Pcs
2	Download line	1Pc	8	Oil can	1Pc	14	Screw St4.2X30	4Pcs

I、Brief Instruction

GA204-108(1311) is a new designed and high efficiency computerized pattern sewing machine for sewing heavy duty materials. It use Servo motor to drive, cam thread take-up, single needle, shuttle hook. It controlled by computer programs, so it can sew the special patterns. The lock stitch is beautiful, flat and well combined. It especially used for sewing signs, leather, power maintenance, rock climbing, overhead work, etc all kinds of safety belts.

II、Features

It adopt advanced electromechanical and pneumatic integration technology, its presser foot lifting device and clamp device are finished by computer to control the cylinder, the feeding mechanism is also controlled by computer program, so it can sew different patterns. The large bobbin decreased changing bobbin frequency.

It is easy for operation, even inexpert can make the perfect stitch. Besides, it can store 1000 patterns, these patterns are created by StyleEdit, the user who can download the self-edited patterns from PC for use at any time.

III、Main Specifications

Max. sewing speed: 800S.P.M	Max. stitch thickness: 12mm
Clearance under prsser foot: 18mm	Bed size: 580X320X550
Needle: DYX3 180-250#	Mainn motor power: 750W
Sewing area: 130X110mm	Air compressor working pressure: 0.6Mpa
Thread: polyester 0.3-1mm	

IV、Operation Instruction

Before using, please carefully read Maintemance Manual.

1. The machine has been adjusted before leaving the factory. According to the ichnography, the user can assemble the machine. (Referring to IX)
2. Insert the interfaces. (Referring to X)
3. Checking machine: Turn the handwheel clockwise, the movement of handwheel and needle should be balanced.
4. Checking clamp: Turn the handwheel, make the needle and presser foot at the top position, push the clamp move to front, back, left and right, the movement should be no resistance. Then move the clamp the center and turn on the power.
5. Before working we must process empty sewing. (Referring to XII)
Note: When process empty sewing, it is better to move off the needle to avoid it broken when to reset the needle, it mrst straightly set to the bottom and fasten the screw.

V、Machine adjustment

1. Adjust presser foot and needle

The presser foot and needle should move synchronously. When the needle puncture the workpiece and to its bottom, the presser foot should press the workpiece tightly, as the shuttle draw the loop, the presser foot lifted. (Pic.1)

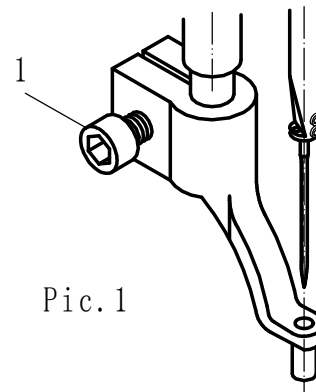

Pic.1

2. Adjust presser foot lift

The height of presser foot should catch the thickness of material. Adjust it upward when to sew the thick material; opposite, adjust it downward. Loosen the screw(1) to move the presser foot upward or downward. (Pic.2)

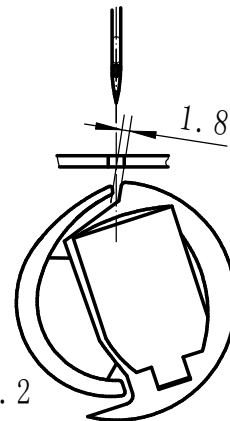

Pic.2

3. Adjust needle and shuttle hook

(1) Thread-off position:

When the needle move to its top position is happen to the needle center the clearance is about 1.8mm. (Pic.2)

(2) Lift needle amount:

When the needle move to its bottom position, the shuttle hook at its max anticlockwise position, at this time the needle moves upward 5.5-6mm, the shuttle tip is at the needle center. The distance between shuttle tip and needle threading hole is 1.5-2mm. (Pic.3)

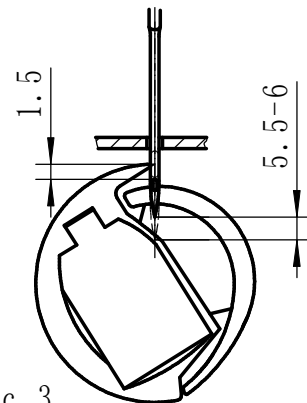

Pic.3

(3) Adjust the clearance of shuttle tip and needle gap:

When the shuttle tip moves to the center of the needle, the clearance between shuttle tip and needle gap is 0.05-0.20mm. (Pic.4)

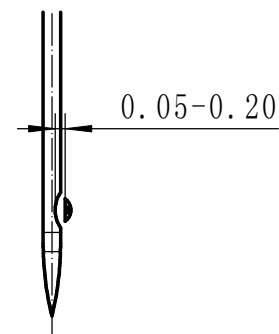

Pic.4

The large clearance, the shuttle tip is hard to draw the thread loop and cause skip thread. The small clearance, the shuttle tip may knock to needle and make the needle broken.

4. Adjust the pressure of presser foot
It is according to the material, light or thick. Turn the screw clockwise to increase the pressure; Opposite to decrease the pressure. (Pic.5)

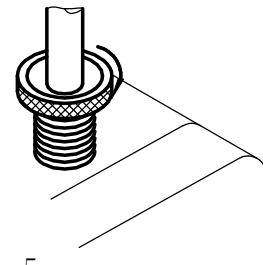

Pic.5

5. Adjust the tension of upper thread and bobbin thread

When normally sewing, the upper thread and bobbin thread should be twisted in the middle of the workpiece. Upper thread loose, it is easy crimpy under the workpiece; Bobbin thread loose, it is easy to loose stitch on the workpiece. Upper thread tension can be adjusted by the thread tension nut. (Pic. 7) And for bobbin thread adjusting, take off the bobbin, loose the screw 2, and adjust the screw 1. (Pic.6)

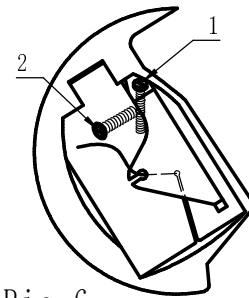

Pic.6

6. Emergency stop operation

When under the condition of thread breaking or run off the bobbin thread, press the emergency stop switch, the machine stops and automatically in the state of empty sewing. After take measure of that, the user can turn the handwheel and make the main shaft to the upper needle position, on the operation panel press "+", "?" to back to the stitch position for continuing sewing. If the user want to stop sewing, press the "Cancel" and quit to empty sewing state.

7. Setup sewing speed

Safety belts require high sewing quality, there are many stitch works and its thickness and pattern are different. The thick place, the stitch is large, and the pattern is complex, so it is need low speed.

Suggestion: New machine should use the low speed.

8. Adjusting the work-piece clamping force

The clamping force must be adjusted when the rope in different floppy range. To realize it by adjusting the button of pressure-reducing valve. Turning clockwise to increase the pressure, counterclockwise to reduce the pressure. The clamping force is directly related to the diameter of the rope. Different ropes should match the different clamp.

VI. Winding the bobbin thread

The machine is equipped with built-in bobbin winder. Place the bobbin onto the bobbin winder shaft 4. Take reference of picture 7, pass the thread through thread tension set 1 and 2. wind the thread several times around the bobbin in direction indicated by arrow, then start the machine to winding the lower thread. Once winding of the bobbin thread is completed, the bobbin set lever 3 will return automatically.

Note: the amount of thread wound onto the bobbin should be a maximum of 80% of the bobbin capacity.

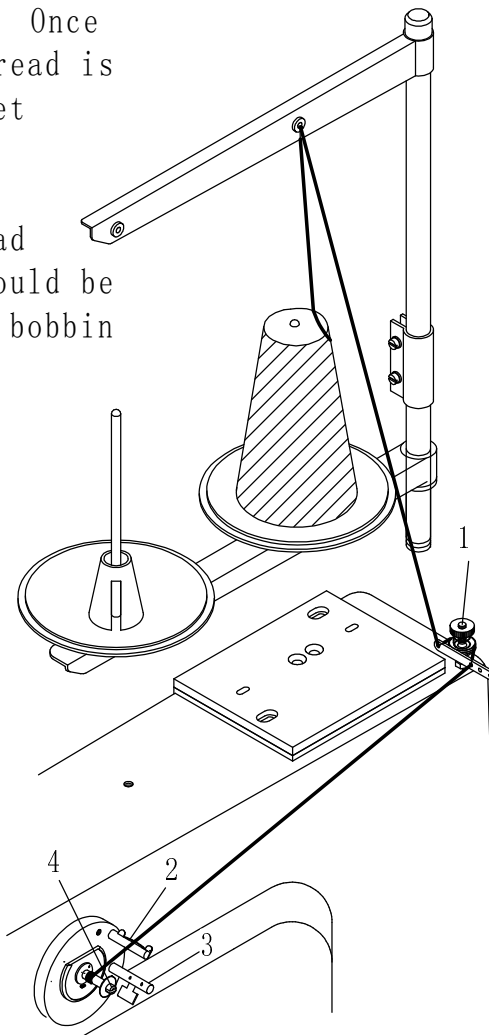

VII、 Threading the upper thread

When threading the upper thread, the needle bar should in top position.

Following the order of 1 to 8 as shown in the illustration given below. (Pic 8)

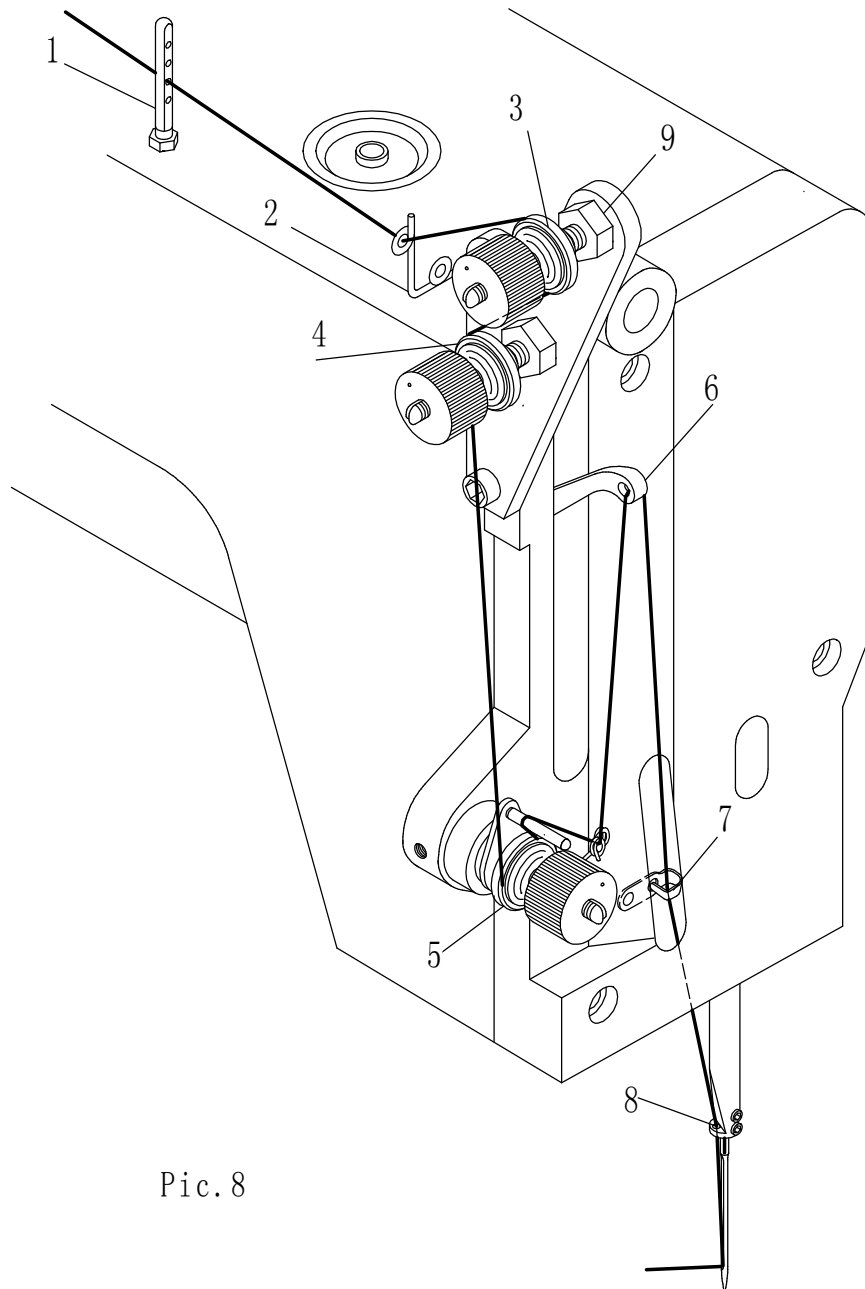

Pic. 8

VIII、Plan view of complete machine

Front view

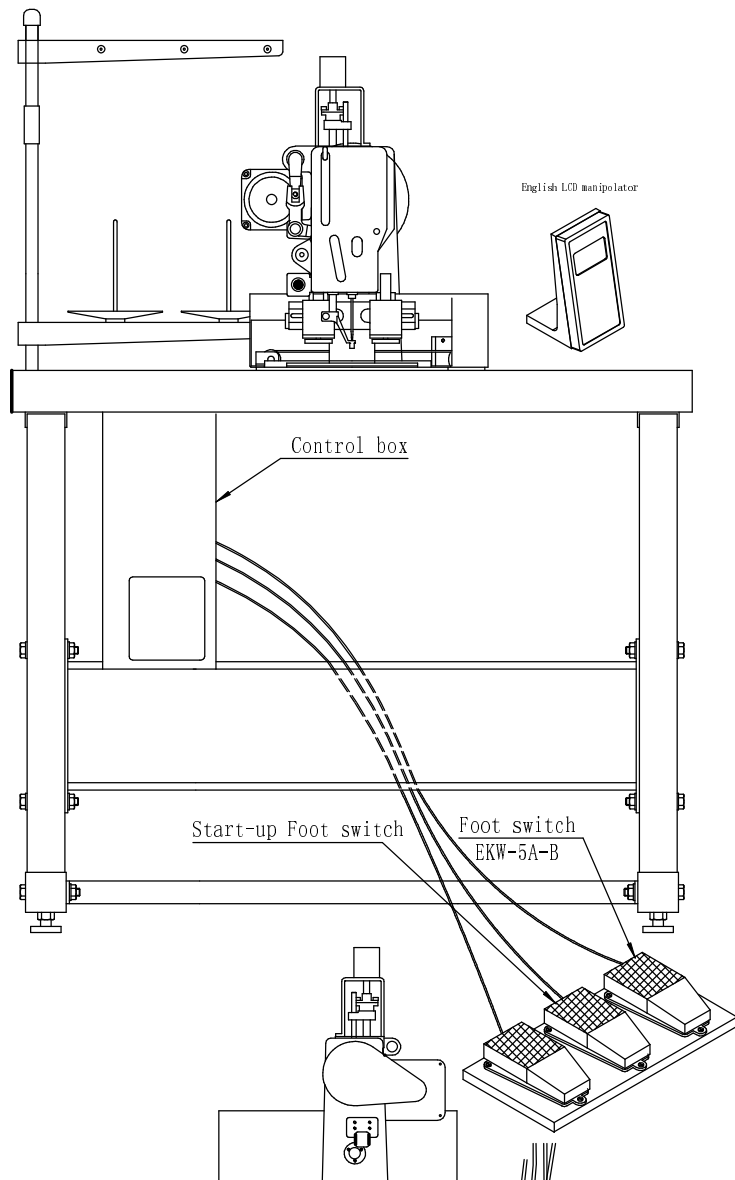

Back view

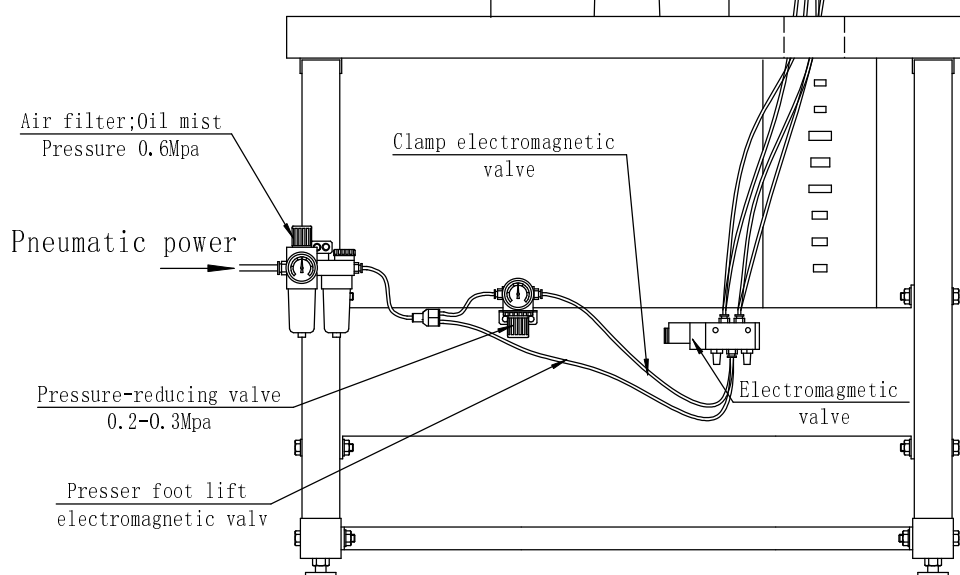

IX、Outside connection



Control box power supply wire

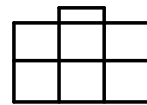
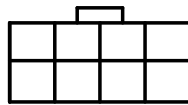
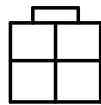

Start-up Foot Witch Y axis stepping motor X axis stepping motor



Principal axis motor

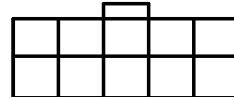

Principal axis motor encoder

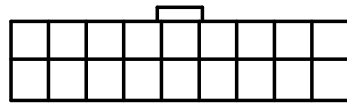

Electromagnetic valve

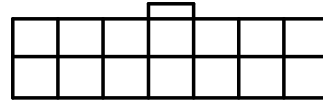

Inductor

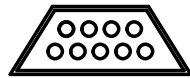

Pattern download wire

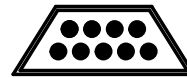

Operation panel

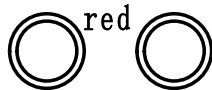

up burn thread

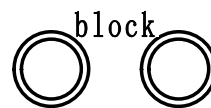

below burn thread

十、零件样本(Parts catalogue)

(一)、机壳组件(Machine hull parts)

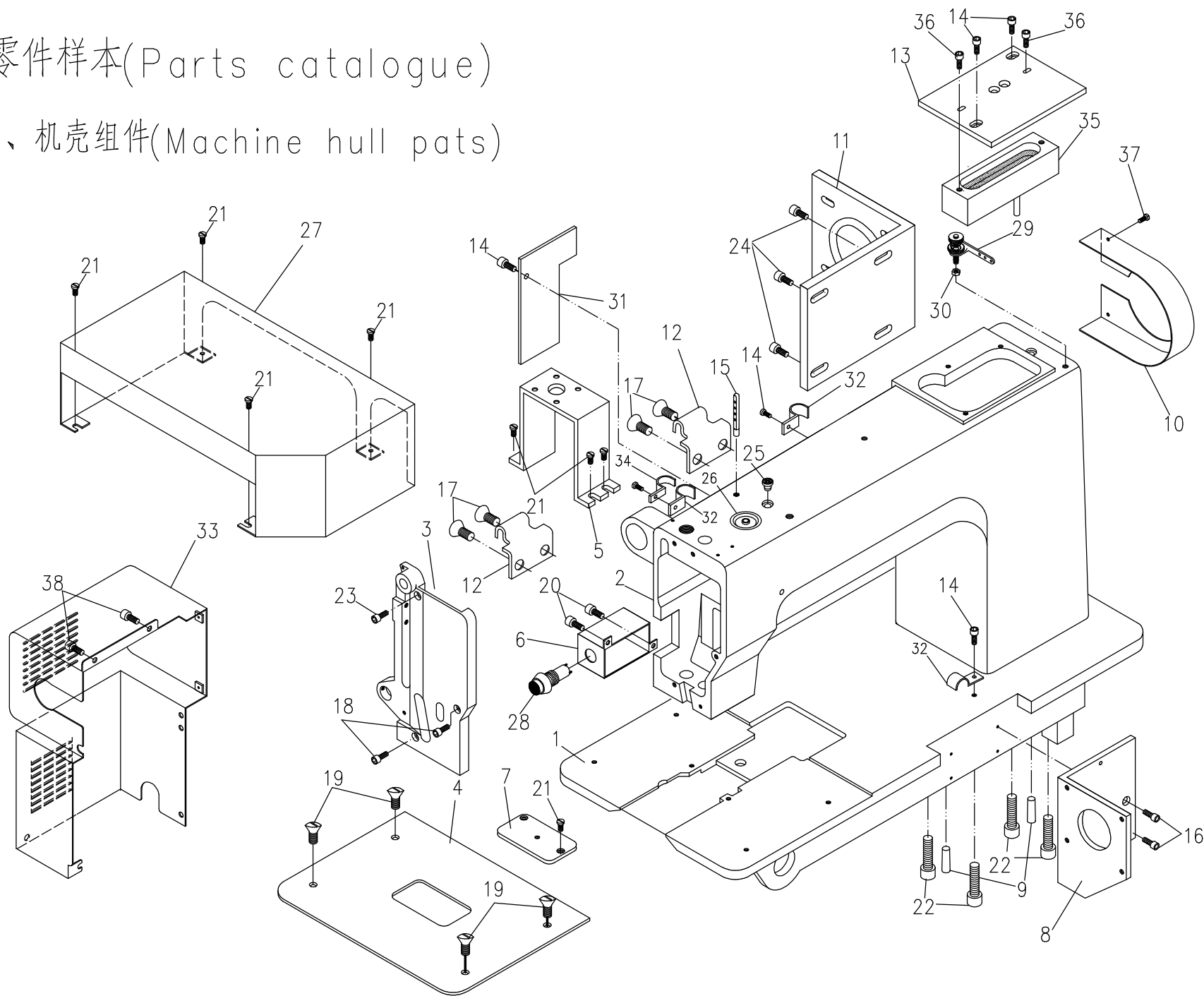

(一)、机壳组件(Machine hull parts)

序号	零件件号	零件名称	Description	件数	备注
1	1070101	底板	bottom plate	1	毛坯同204-370
2	1070102	机壳	head case	1	
3	SF0104	前盖	face plate	1	
4	1070104	缝台板	sewing board	1	
5	1070105	抬压脚汽缸支座	cylinder support	1	
6	1070106	急停开关防护罩	shield cap	1	
7	1070107	针板	needle plate	1	
8	1070108	纵向电机座	electromotor support	1	
9	GS105	机壳销	pin	2	
10	1070110	皮带罩	belt hood	1	
11	1070111	主轴电机支承板	electromotor support	1	
12	GXR222	合页2	hinge 2	2	
13	GK201	上盖板	upper cover plate	1	
14	GS13310	上盖板螺钉	screw	4	
15	GS101	穿线钉	threading screw	1	
16	GS13320	纵向电机座螺钉	screw	4	
17	GS17520	合页2螺钉	screw	4	
18	GS13325	前盖板螺钉	screw	2	
19	GS16212	缝台板螺钉	screw	4	
20	GS13212	开关防护罩螺钉	screw	2	
21	GS172	针板螺钉	screw	11	
22	GS13635	机壳螺钉	screw	4	
23	GS13318	前盖板螺钉	screw	1	
24	GS13416	电机支承板螺钉	screw	4	
25	GK209A	小油堵	small oil seal	4	
26	GK208	大油堵	big oil seal	1	
27	1080127	防尘罩	shield cap	1	
28	1070128	急停开关	switch	1	
29	1070131	绕线器夹线组件	tensin threed stand	1	
30	GL203	螺母	nut	1	
31	1070133	小窗口盖板	cover plate	1	
32	1070134	电线压板	press plate	3	
33	1070139	电机罩	electromotor shield cap	1	
34	1070136	电线压板	press plate	1	
35	GK203	油盒	oil box	1	
36	GS12212	油盒螺钉	screw	2	
37	GS12104	护针板螺钉	screw	2	借用204
38	GS12310	电机罩螺钉	screw	4	
39					
40					
41					
42					
43					
44					

(二)、上轴、挑线组件(Arm shaft and thread take-up)

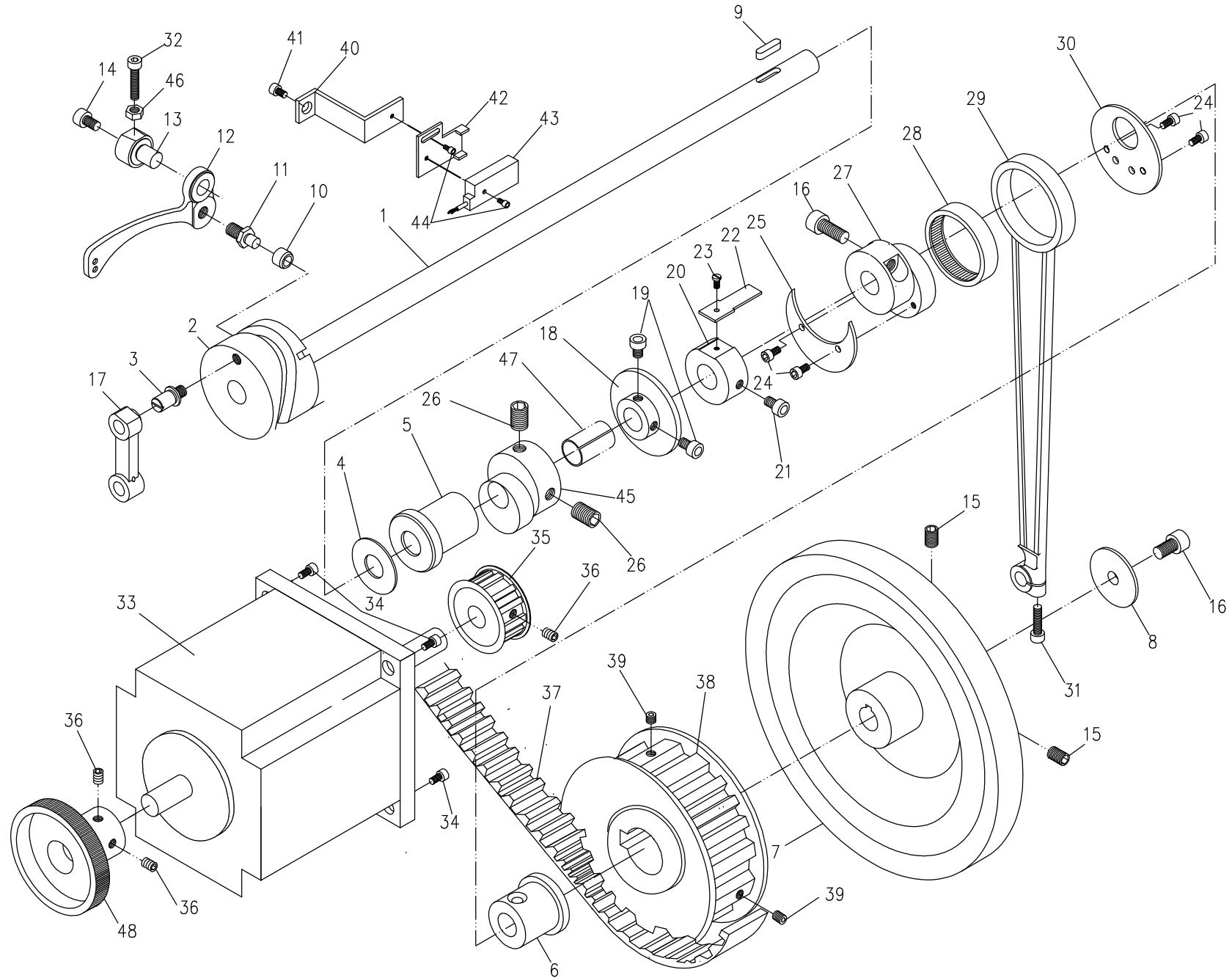

(二)、上轴、挑线组件(Arm shaft and thread take-up)

序号	零件件号	零件名称	Description	件数	备注
1	GZ107	上轴	upper shaft	1	108A借用GA204-420上轴
2	GP104	挑线凸轮	raising thread cam	1	
3	GX100	挑线凸轮连杆销钉	screw	1	
4	GS215	前轴套垫片	washer	1	
5	G0109	上轴前轴套	shaft bushing front	1	
6	G0107	上轴后轴套	shaft bushing back	1	
7	1070207	大皮带轮	on turns	1	
8	GK217	皮带轮垫片	washr	1	
9	GK216	上轴键	upper shaft key	1	
10	GU100	挑线滚轮	roller shaft	1	
11	GZ105	挑线滚轮轴	roller shaft screw	1	
12	M0212	挑线杆	thread take-up lever	1	
13	M0213	挑线杆轴	raising thread shaft	1	
14	GS13412	挑线杆轴螺钉	screw	1	
15	GS11516	皮带轮紧固螺钉	screw	2	
16	GS13525	皮带轮安全螺钉	screw	2	
17	1070217	针杆连杆	small connecting rod	1	
18	GP112	主动摩擦轮	driving frictiong wbeel	1	
19	GS13410	主动摩擦轮螺钉	screw	2	
20	1070220	上轴感应铁固定环	fixer loop	1	
21	GS13412	固定环螺钉	screw	2	
22	1070222	上轴感应铁	iron-inductor	1	
23	GS12206	感应铁螺钉	screw	1	
24	GS13206	偏心套挡片螺钉	screw	4	
25	GK237	偏心挡片B	side plate(B)	1	
26	GS11510	偏心套紧定螺钉M8X1	screw	1	
27	G0129	偏心套	eccentric sleeve	1	
28	HK4512	轴承	needle roller bearing	1	
29	GH129	大连杆体	connecting rod	1	
30	GK236	偏心挡片A	side plate(A)	1	
31	GS13316	大连杆体紧固螺钉	screw	1	
32	GS13440	挑线杆轴紧固螺钉	screw	1	
33	1070233	主轴电动机	electromotor	1	
34	GS13316	主轴电机安装螺钉	screw	4	
35	1070235	主轴电动机带轮	electromotor wheel	1	
36	GS11405	电机带轮紧固螺钉	screw	2	
37	1070237	同步带	in-phase belt	1	
38	1070238	主轴带轮	principal axis wheel	1	
39	GS11416	主轴带轮紧固螺钉	screw	2	
40	1070240	上轴传感器支座	sensor support	1	
41	GS13310	支座螺钉	screw	1	
42	1070242	上轴传感器固定架	sensor rivet support	1	
43	1070243	传感器	sensor	1	
44	GS13108	传感器螺钉	screw	2	
45	1070245	压脚升降偏心轮	presser foot lift cam	1	
46	GL106	锁紧螺母	nut	1	
47	1070247	偏心内套	eccentric sleeve bushing	1	
48	1070247	主电机手轮	electromotor wheel	1	
49					
50					

(三)、针杆、压杆组件(Needle bar and presser bar)

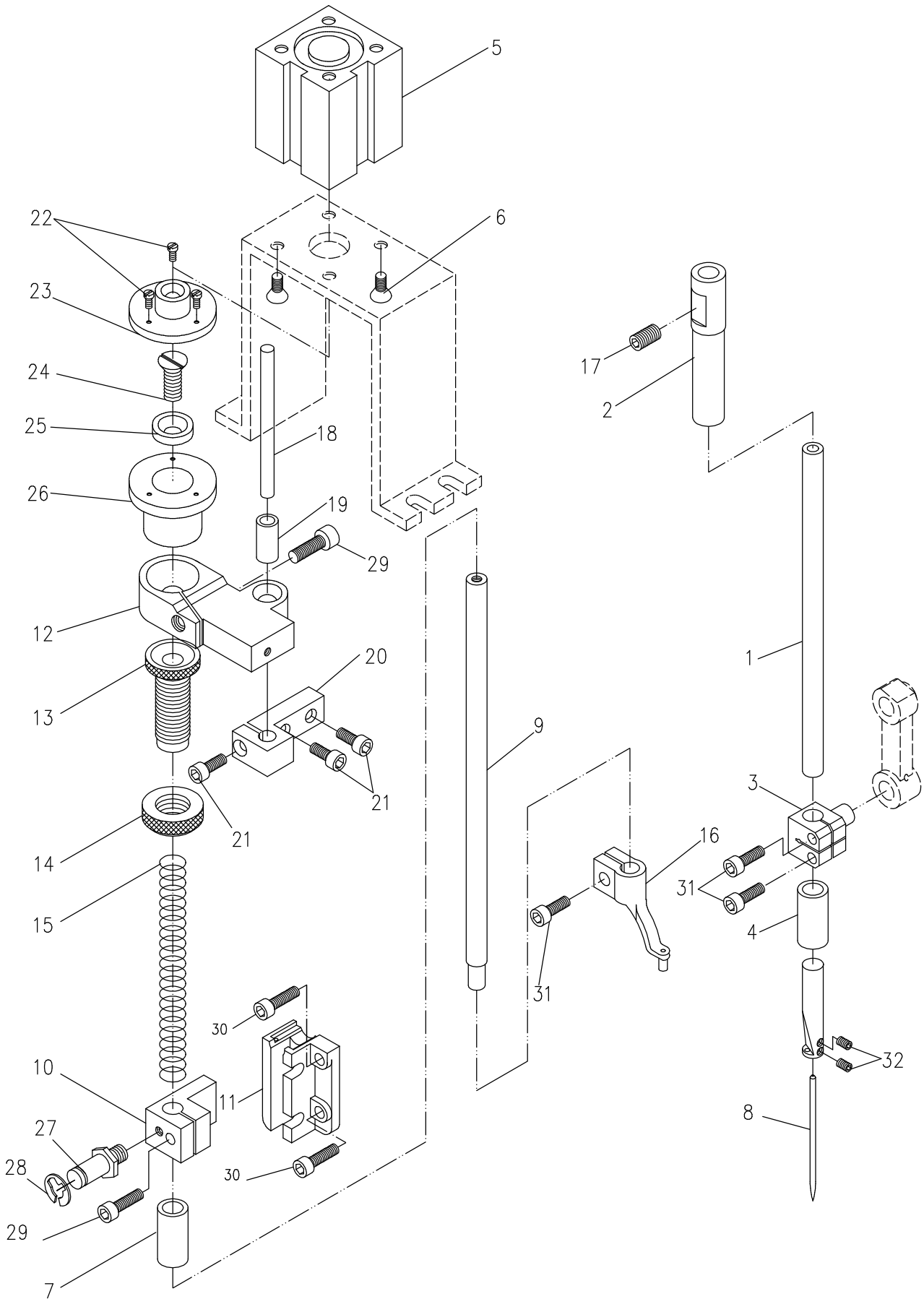

(三)、针杆、压杆组件(Needle bar and presser bar)

序号	零件件号	零件名称	Description	件数	备注
1	1070301	针杆	needle bar	1	
2	M0302	针杆上衬套	bushing	1	
3	GH118	针杆连接轴	needle bar connecting shaft	1	
4	M0304	针杆下衬套	bushing	1	
5	1070305	压脚提升汽缸	cylinder	1	
6	GS16312	汽缸固定螺钉	screw	4	
7	M0307	压杆下衬套	pressing rod lower bushing	1	
8	DY×3	机针	needle	1	
9	1070309	压杆	pressing rod	1	
10	1070310	压杆导架	oriented bracket of pressing rod	1	
11	GK226	压脚升降定位滑道	presser lifting locating slideway	1	
12	1070312	压脚提升导向块	block	1	
13	GZ125	调压螺钉	presser regulated screw	1	
14	M0314	调压锁紧螺母	nut	1	
15	GW201	压杆大簧	presser bar big spring	1	
16	1070316	压脚	presser foot	1	
17	GS11306	针杆上衬套螺钉	screw	1	
18	1070318	压脚提升导向杆	presser oriented shaft	1	
19	GU105	针杆连接轴滚柱	roller	1	同GB180-2
20	1070320	压脚提升导向座	presser oriented support	1	
21	GS13216	导向座螺钉	screw	2	
22	GS13212	压脚提升套筒端盖螺钉	screw	3	
23	1070323	压脚提升套筒端盖	sleeve lid	1	
24	GS16316	压杆端盖螺钉	screw	1	
25	1070325	压杆端盖	screw	1	
26	1070326	压脚提升套筒	sleeve	1	
27	1070327	抬压脚连杆螺钉	screw	2	
28	E-05	开口挡圈	block ring	2	
29	GS13320	压杆导架紧固螺钉	screw	2	
30	GS13325	滑道螺钉	screw	2	
31	GS13316	针杆连接轴螺钉	screw	3	
32	GS11205	针夹螺钉	screw	2	
33					
34					
35					
36					
37					
38					
39					
40					
41					
42					
43					
44					

(四) 下轴、摆轴组件(Lower shaft and pendulum shaft)

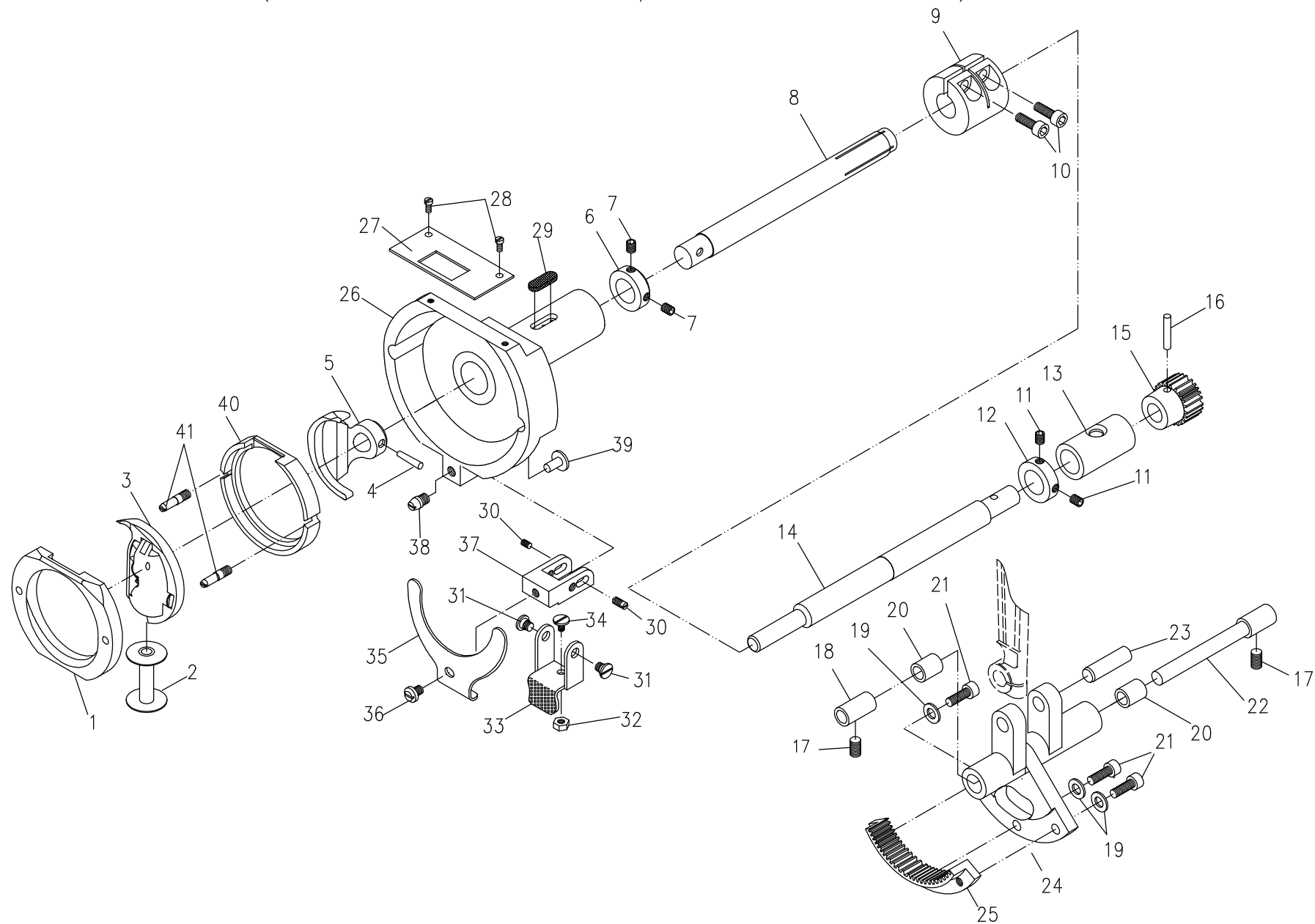

(四) 下轴、摆轴组件(Lower shaft and pendulum shaft)

序号	零件件号	零件名称	Description	件数	备注
1	GN118	梭床盖	bobbin bed cover	1	
2	GN116	梭心	bobbin	1	
3	GN111/9	摆梭	shuttle hook	1	
4	GX121	摆梭托锥肖	pin	1	
5	GR258	摆梭托	swinging shuttle support	1	∅3X21
6	GK242	下轴Ⅱ挡圈	block ring	1	
7	GS11305	下轴挡圈紧定螺钉	screw	2	
8	GZ113	下轴Ⅱ	below axis Ⅱ	1	
9	GZ239	下轴紧圈	tight ring of lower shaft	1	
10	GS13416	下轴紧圈螺钉	screw	2	
11	GS11305	下轴Ⅰ挡圈螺钉	screw	2	
12	GK240	下轴Ⅰ挡圈	biocking ring of lower shaft	1	
13	C0131	下轴轴套	back shaft bushing	1	
14	GZ112	下轴Ⅰ	lower shaft(1)	1	
15	GP107	下轴小齿轮	small gear of lower shaft	1	
16	M0415	小齿轮锥销	pin	1	
17	GS10414	下摆轴轴套螺钉	screw	2	
18	G0130	下摆轴轴套	bushing	1	
19	M0519	扇形齿轮螺钉垫圈	washer	3	
20	G0132	下摆轴架小套	bushing	2	
21	GS13318	扇形齿轮紧固螺钉	screw	3	
22	GZ111	下摆轴	swinging shaft	1	
23	GZ128	大连杆销轴	shaft	1	
24	GK238	摆轴架	pendulum axle stand	1	
25	GP106	扇形齿轮	pendulum axle fan-shaped gear	1	
26	GN117	梭床座	body of shuttle bed	1	
27	M0417	护针挡片	needle protectting board	1	
28	GS12104	护针板螺钉	screw	2	
29	GK249	梭床油毡垫	oil felt	1	
30	GS10208	压紧架转轴螺钉	screw	2	
31	GX112	板手转轴螺钉	screw	2	
32	GL203	板手轴位螺母	nut	1	
33	GK243	压紧架板手	press stang spanner	1	
34	GX113	板手轴位螺钉	screw	1	
35	GW111	压盖簧	ring-pressing spring	1	
36	GX117	压盖簧螺钉	screw	1	
37	GK241	梭床压紧架	bobbin bed press stand	1	
38	GX109	压紧架轴位螺钉	screw	1	
39	GX108	压紧架轴位销钉	screw	1	
40	GN110	梭床	bobbin bed	1	
41	GS163	梭床螺钉	bobbin bed screw	2	
42					
43					
44					

(五)、同步压脚升降组件(Presser foot lift timing)

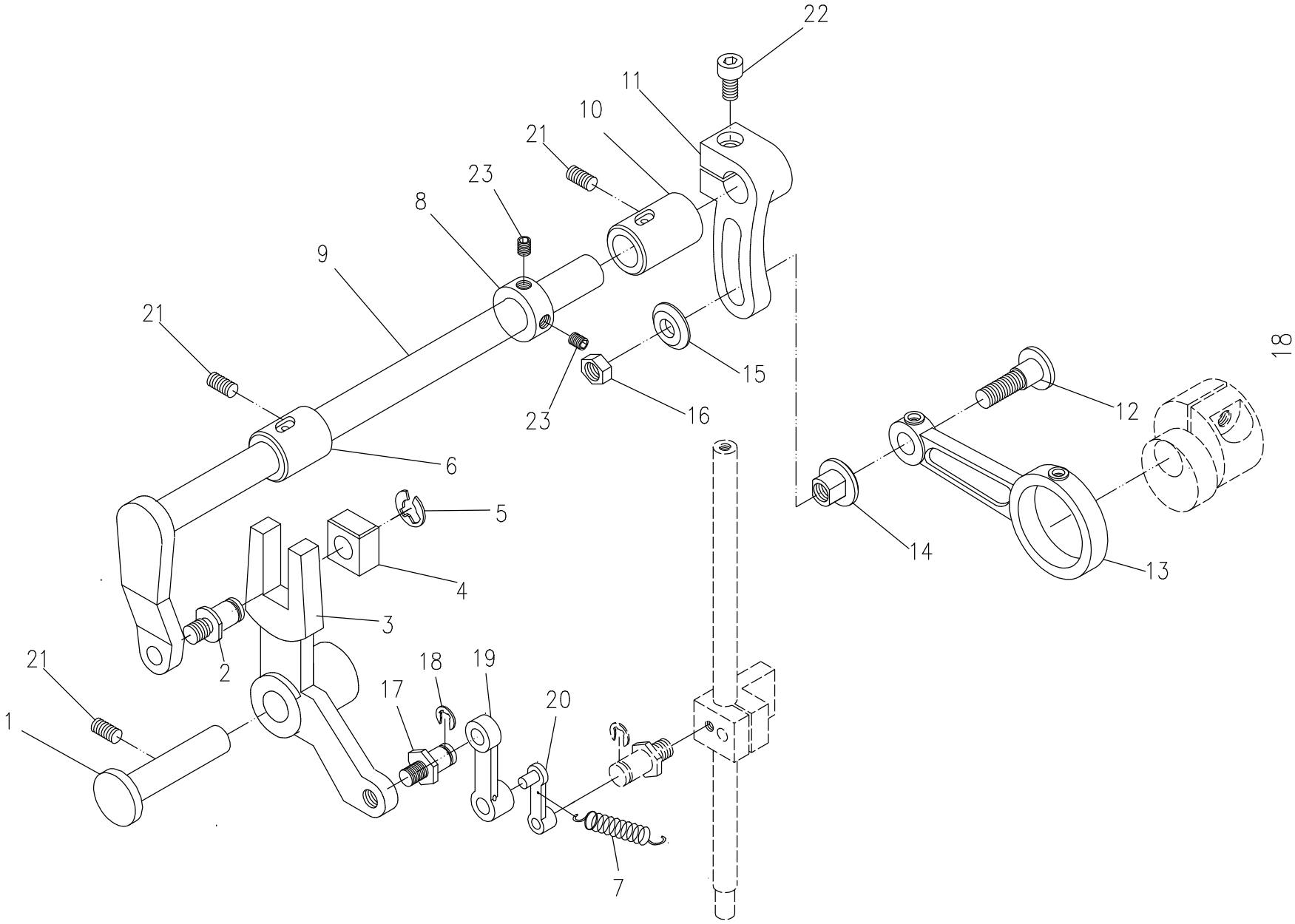

(五)、同步压脚升降组件(Presser foot lift timing)

序号	零件件号	零件名称	Description	件数	备注
1	810-1216	挑线曲柄连杆销	pin	1	
2	GZ136	抬牙滑块销钉	pin	1	
3	1070503	压脚升降叉杆	presser foot lift feeth fork	1	
4	GU111	铜滑块	glide block	1	
5	GW203	抬牙轴卡簧	shaped snap spring	1	
6	G0127	压脚升降轴前轴套	lifting shaft front sleeve	1	
7	GW122	绕线器拉簧	spring	1	
8	SF1303	压脚升降轴挡圈	lifting shaft blocking ring	1	
9	1070509	压脚升降轴	pressing foot lift shaft	1	
10	G0126	压脚升降轴后轴套	lifting shaft back sleeve	1	
11	GH146	压脚升降调整后曲柄	lifting adjusting back crank	1	
12	GS150	轴位螺钉	screw	1	
13	GD0606	压脚升降偏心轮连杆	lifting connecting rod	1	
14	GL108	调整螺母	nut	1	
15	GR245	轴位螺钉垫圈	washer	1	
16	GL106	锁紧螺母	nut	1	
17	1070327	抬压脚连杆螺钉	screw	1	
18	E-05	开口挡圈	E-type	2	
19	1070519	抬压脚连杆(下)	below connecting rod	1	
20	1070520	抬压脚连杆(上)	top connecting rod	1	
21	GS11308	压脚升降轴前后轴套螺钉	screw	3	
22	GS13416	压脚升降曲柄螺钉	screw	1	
23	GS11306	升降轴挡圈螺钉	screw	2	
24					
25					
26					
27					
28					
29					
30					
31					
32					
33					
34					
35					
36					
37					
38					
39					
40					
41					
42					
43					
44					

(六)、横向传动组件(Horizontal transmission) 5

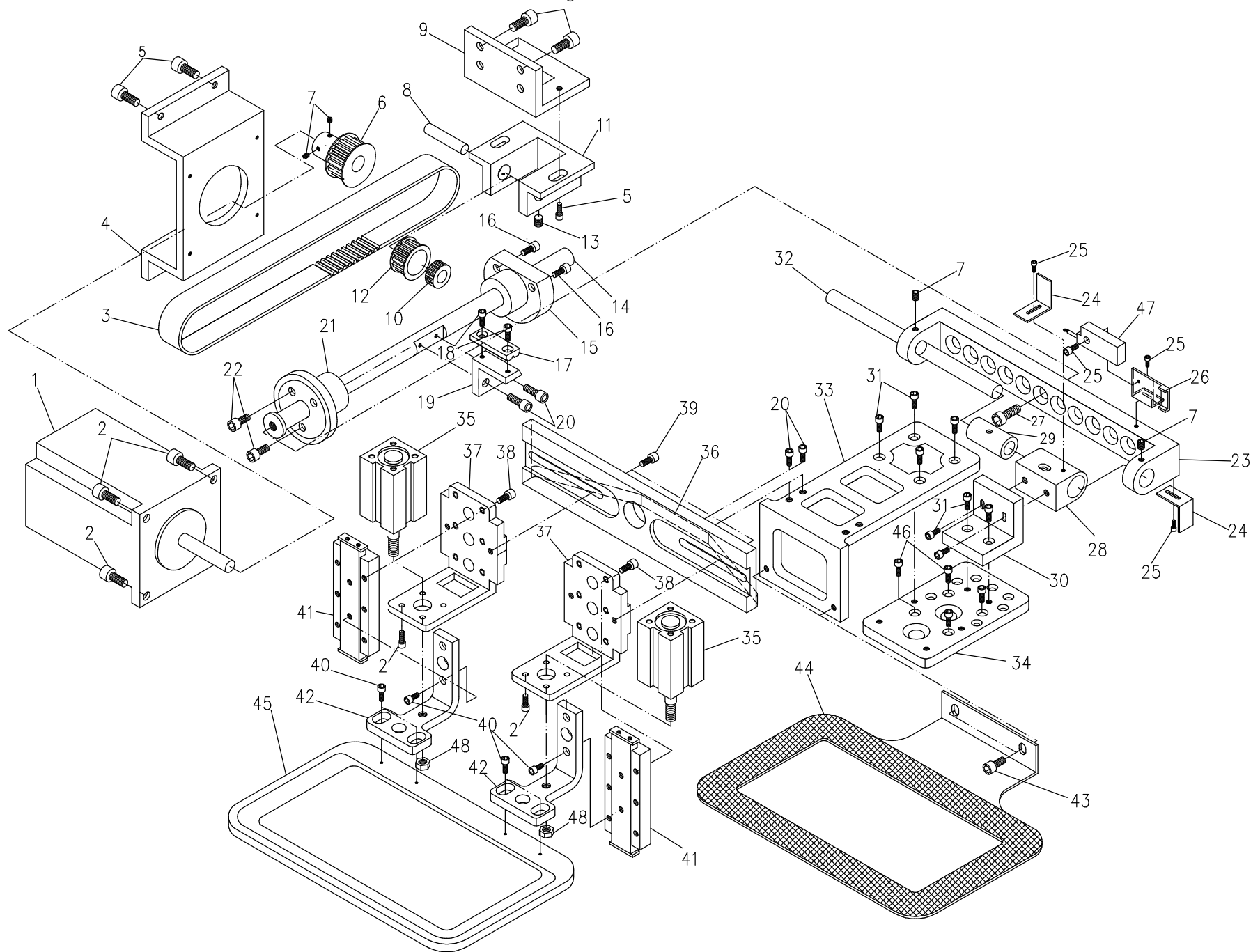

(六)、横向传动组件(Horizontal transmission)

序号	零件件号	零件名称	Description	件数	备注
1	1070601	横向电动机	electromotor	1	
2	GS13216	电机安装螺钉	screw	6	
3	1070603	横向同步带	synchronization belt	1	
4	1070604	横向电机座	electromotor support	1	
5	GS13316	电机座安装螺钉	screw	4	
6	1070606	电机带轮	belt pulley	1	
7	GS11305	电机带轮紧定螺钉	screw	2	
8	1070608	被动带轮轴	belt pulley axis	1	
9	1070609	带轮支架	belt pulley support	1	
10	GK09108	挑线杆轴承	belt pulley bearing	2	同GA-204
11	1070611	被动带轮支座	belt pulley support	1	
12	1070612	被动带轮	belt pulley	1	
13	GS11205	带轮轴紧定螺钉	screw	2	
14	1070614	横向导向轴	oriented axis	1	
15	1070615	横向导向轴后套	back sleeve	1	
16	GS13318	后套安装螺钉	screw	3	
17	1070617	横向齿形带压板	dentiform prees board	1	
18	GS13110	齿形带压板螺钉	screw	2	
19	1070619	皮带固定座	belt fixer	1	
20	GS13210	固定座螺钉	screw	6	
21	1070621	横向导向轴前套	front sleeve	1	
22	GS13310	前套安装螺钉	screw	3	
23	1070623	纵向导向轴支架	oriented axis support	1	
24	1070624	感应铁	iron-inductor	1	
25	GS13106	感应铁螺钉	screw	4	
26	1070242	纵向感应器固定架	fixer support	1	
27	GS13416	横向导向轴固定螺钉	screw	1	
28	1070628	导向座	oriented support	1	
29	G0141	拾牙轴套	sleeve	1	同GB180-2
30	1070630	导向弯板	bend board	1	
31	GS13310	弯板安装螺钉	screw	8	
32	1070632	纵向导向轴	oriented axis	1	
33	1080633	绣框支架	sew up support	1	
34	1070634	导向座基板	dorienterd board	1	
35	1080635	夹紧汽缸	clamp cylonder	2	
36	1080636	左右压脚支座	presser foot support	1	
37	1080637	汽缸支座	cylinder support	2	
38	GS13110	汽缸支座螺钉	screw	12	
39	GS13212	支座连接螺钉	screw	4	
40	GS13206	连接板螺钉	screw	8	
41	1080641	导向座组件	orienterd support	2	
42	1080642	压脚连接板	presser foot board	2	
43	GS13208	下绣框螺钉	screw	2	
44	1080644	下绣框	below sew up case	1	
45	1080637	上绣框	top sew up case	1	
46	GS13112	导向座基板螺钉	screw	4	
47	1070243	感应器	sensor	1	
48	GL106	锁紧螺母	nut	2	
49					
50					

(七)、纵向转动组件(Vertical transmission)

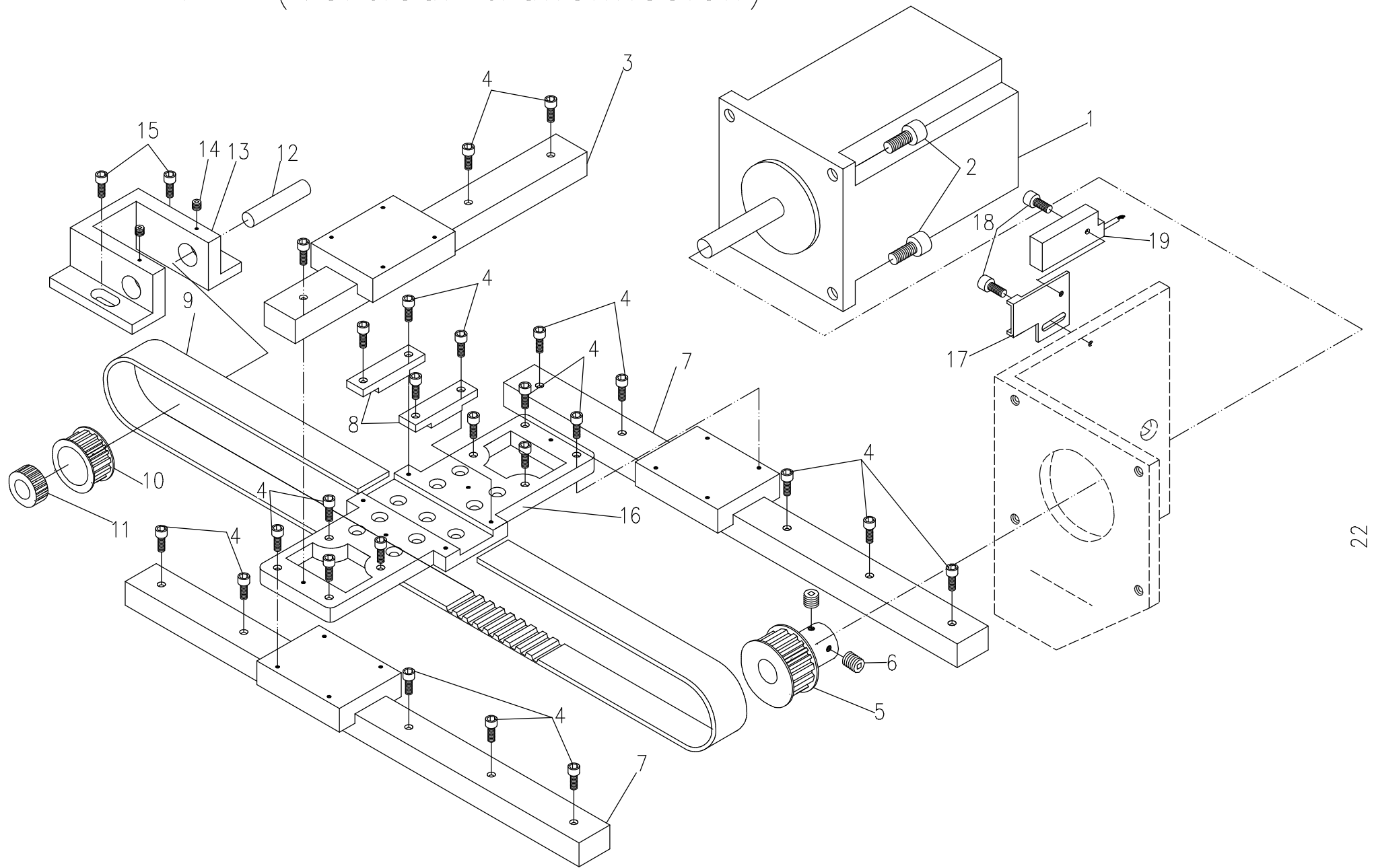

(七)、纵向转动组件(Vertical transmission)

序号	零件件号	零件名称	Description	件数	备注
1	1070701	纵向电动机	electromotor	1	
2	GS13212	电机安装螺钉	screw	4	
3	1070703	横向直线导轨	linear guideway	1	
4	GS13112	导轨安装螺钉	screw	28	
5	1070606	电机带轮	belt pulley	1	
6	GS11305	带轮紧定螺钉	screw	2	
7	1070707	纵向直线导轨	linear guideway	2	
8	1070708	纵向齿形带压板	belt press board	2	
9	1070709	纵向同步带	synchronization belt	1	
10	1070612	被动带轮	belt pulley	1	
11	GK09108	挑线杆轴承	belt pulley bearing	1	同GA-204
12	1070608	被动带轮轴	belt pulley axis	1	
13	1070611	被动带轮支座	belt pulley support	1	
14	GS11205	带轮轴紧定螺钉	screw	2	
15	GS13316	被动带轮支座螺钉	screw	2	
16	1070716	纵向导轨连接板	connet board	1	
17	1070242	上轴传感器固定架	fixer support	1	
18	GS13106	传感器固定架螺钉	screw	2	
19	1070243	传感器	sensor	1	
20					
21					
22					
23					
24					
25					
26					
27					
28					
29					
30					
31					
32					
33					
34					
35					
36					
37					
38					
39					
40					
41					
42					
43					
44					

(八)、夹线、过线组件(Thread tension)

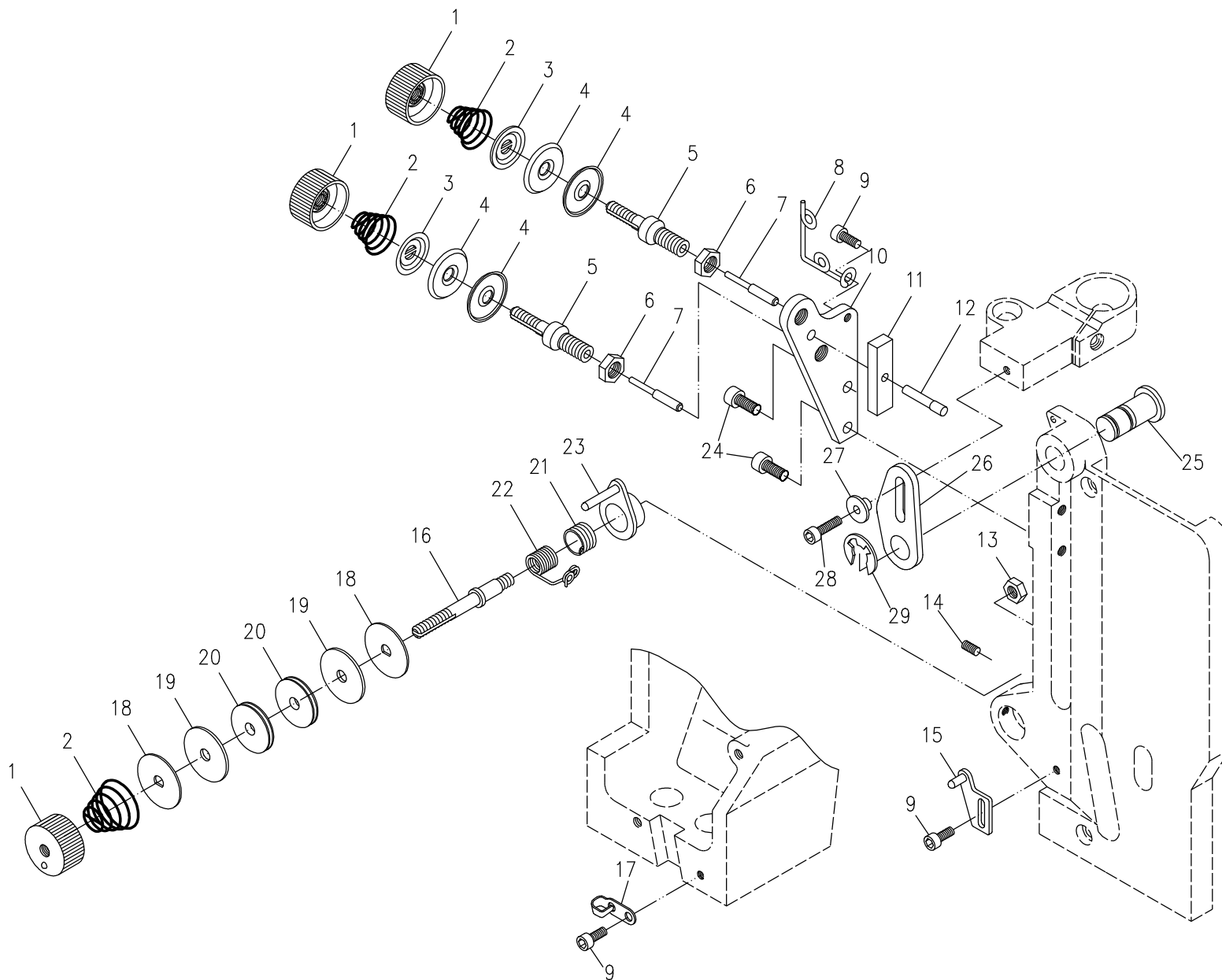

(九)、夹线、过线组件(Thread tension)

序号	零件件号	零件名称	Description	件数	备注
1	GLS204	夹线螺母	tension nut	3	
2	GW115	夹线簧	spring	3	
3	GK232	松线板	thread releasing plate	2	
4	GK123	夹线板	tension plate	4	
5	GZ126	夹线螺钉	screw tension	2	
6	GL205	锁紧螺母	nut	2	
7	GX106	松线钉	loosen bolt	2	
8	M0908	过线圈	thread passing ring	1	
9	GS13208	过线圈螺钉	screw	3	
10	M0910	夹线架	thread tension rack	1	
11	M0911	松线板1	thread releasing plate	1	
12	M0912	松线板销	pin	1	
13	GL204	过线螺钉锁母	nut	1	
14	GS11206	过线器座固定螺钉	screw	1	
15	GKS108	拨簧支架	drawing spring stand	1	
16	M0916	过线螺钉	screw tension	1	
17	GC0819	拦线钩	finger	1	
18	GK233	过线板	thread passing plate	2	
19	GK234	过线轮毡圈	washer	2	
20	GP102	过线轮	thread passing wheel	2	
21	GW109	挑线簧2	thread take-up spring2	1	
22	GW108	挑线簧1	thread take-up spring1	1	
23	GKS107	过线器座	thread passing sead	1	
24	GS13316	松线架螺钉	screw	1	
25	1070825	松线板定位轴	shaft	2	
26	1070826	松线压板	thread releasing plate	1	
27	M0804	松线板连接套	thread loosing sleeve	1	
28	GS13216	连接套螺钉	screw	1	
29	GW211	松线板定位轴卡簧	jump ring	1	
30					
31					
32					
33					
34					
35					
36					
37					
38					
39					
40					
41					
42					
43					
44					

(九)、内置绕线器组件(Built-in bobbin winder)

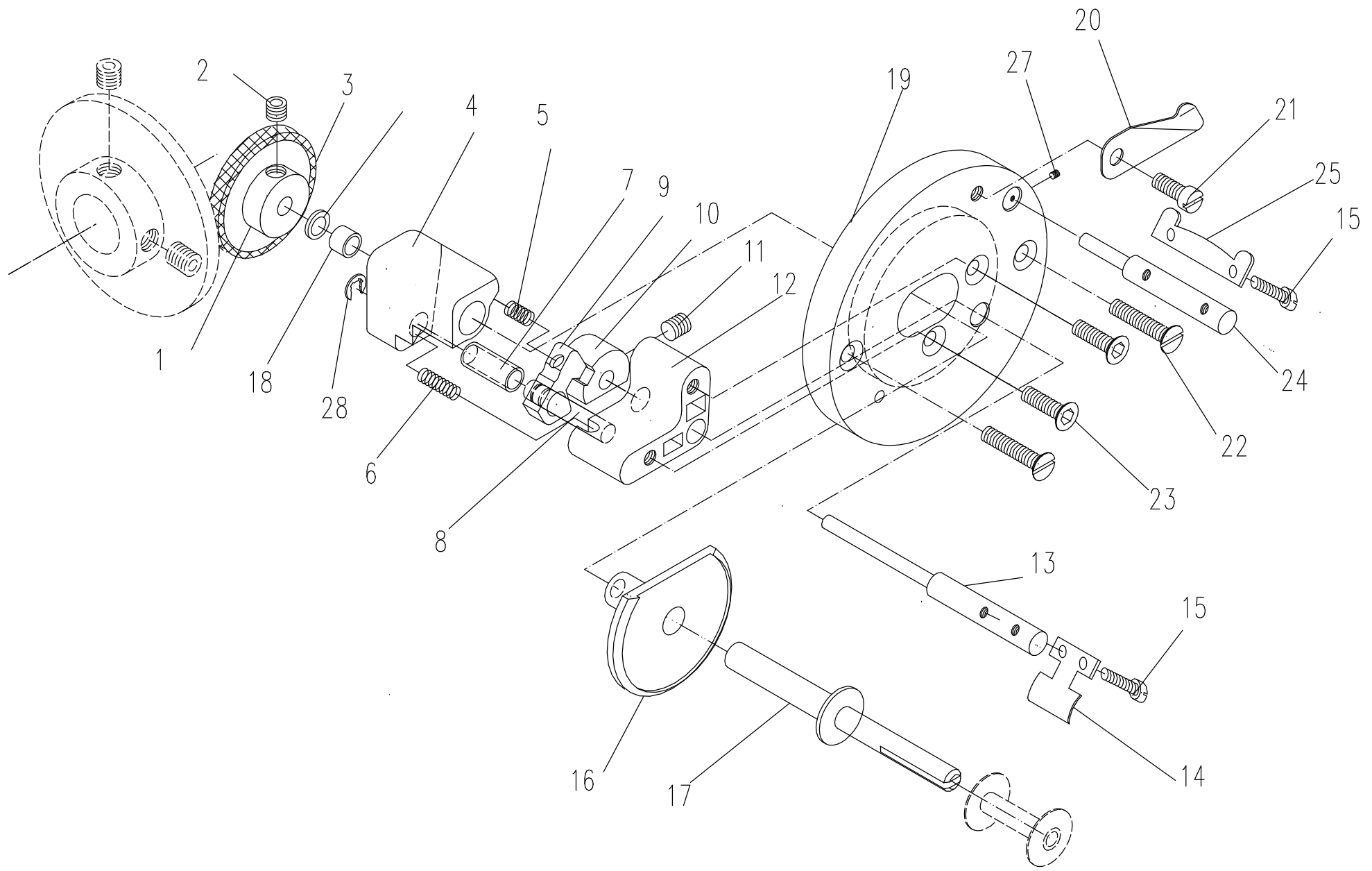

(九)、内置绕线器组件(Built-in bobbin winder)

序号	零件件号	零件名称	Description	件数	备注
1	EL0918	被动摩擦轮胶圈	rubber ring	1	
2	GS11306	被动摩擦轮紧定螺钉	screw	1	
3	EL0920	被动摩擦轮	driven friction wheel	1	
4	EL0921	绕线压力板座	thread coiling presser plate seat	1	
5	EL0922	压力弹簧2	presser spring 2	1	
6	EL0923	压力弹簧1	presser spring 1	1	
7	EL0925	压力板小套	presser plate small bushing	1	
8	EL0924	压力板芯轴	presser plate shaft	1	
9	EL0926	绕线压力板	thread coiling presser plate	1	
10	EL0927	绕线控制板	thread coiling controller plate	1	
11	GS11305	绕线控制板顶丝	screw	1	
12	EL0929	绕线控制板座	thread coiling controller plate seat	1	
13	1070913	满线跳板轴	full reel springboard shaft	1	
14	1070914	满线跳板	full reel springboard	1	
15	GS13112	满线跳板调整螺钉	regulate screw	1	
16	EL0933	压力板底座	presser plate base dial	1	
17	1070917	梭心轴	bobbin shaft	1	
18	EL0941	绕线压力板座套	thread coiling presser plate washer	1	
19	EL0936	绕线器接盘	bobbin winder connecting dial	1	
20	EL0937	小剪刀	small scissors	1	
21	GS13208	小剪刀紧固螺钉	screw	2	
22	GS17212	绕线器接盘螺钉	screw	2	
23	GS16210	绕线器接盘螺钉	screw	2	
24	1070924	排线板轴	shaft	1	
25	1070925	排线板	plate	2	
26	D-05	摩擦轮平垫	washing	2	
27	GS11105	排线轴紧定螺钉	screw	2	
28	E-04	开口挡圈	E-type	1	
29					
30					
31					
32					
33					
34					
35					
36					
37					
38					
39					
40					
41					
42					
43					
44					

(十)、台板、机架组件(Table top and stand)

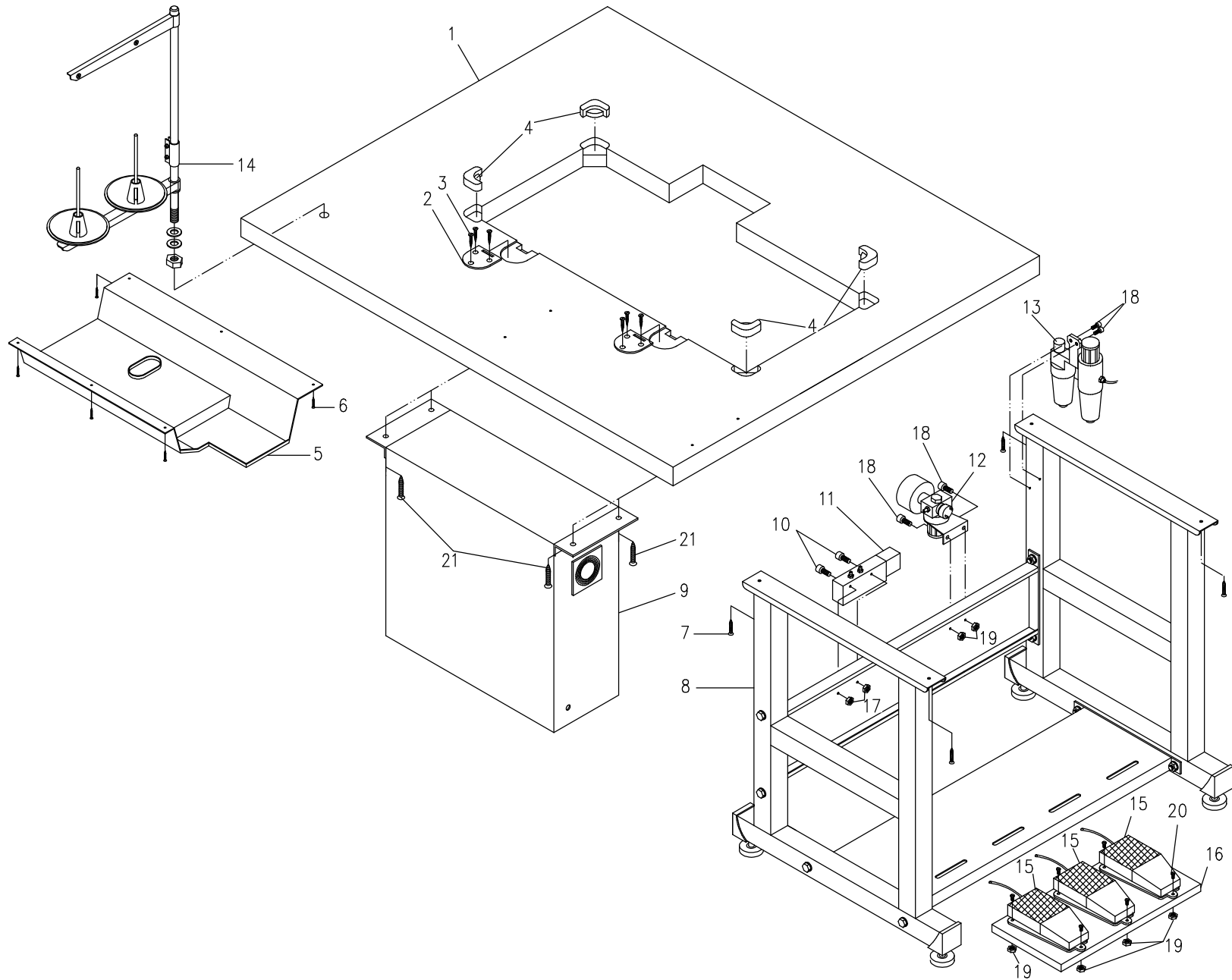

(十)、台板、机架组件(Table top and stand)

序号	零件件号	零件名称	Description	件数	备注
1	1071001	台板	table	1	
2	GKR200	合页1	hinge	2	
3	GC1005	合页螺钉	screw	6	
4	GC1004	机头胶垫	rupper cushion	4	
5	GKR216	接油盘	oil pan	1	
6	GBS112	木螺钉	screw	6	
7	GC1021	机架台板紧固螺钉	screw	4	
8	1071008	机架	stand	1套	
9	1071009	电控箱	electron control	1	
10	GS13280	电磁阀螺钉	screw	2	
11	1071011	电磁阀	electromagnetisin valve	3	
12	1071012	减压阀及空气压力开关两连件	decompress valve and switch	1	
13	1011013	空气油雾滤清器	air-oil filter	1	
14	M1014	线架	thread stand	1套	
15	1071015	脚踏开关	jury-mast switch	3	
16	1071016	脚踏开关底板	pedal	1	
17	GL204	电磁阀安装螺母	nut	2	
18	GS13312	螺钉	screw	4	
19	GL205	螺母	nut	11	
20	GS12312	脚踏开关固定螺钉	screw	9	
21	ST6.3X30	电控箱自攻螺钉	screw	4	
22					
23					
24					
25					
26					
27					
28					
29					
30					
31					
32					
33					
34					
35					
36					
37					
38					
39					
40					
41					
42					
43					
44					

UPPER BURNER

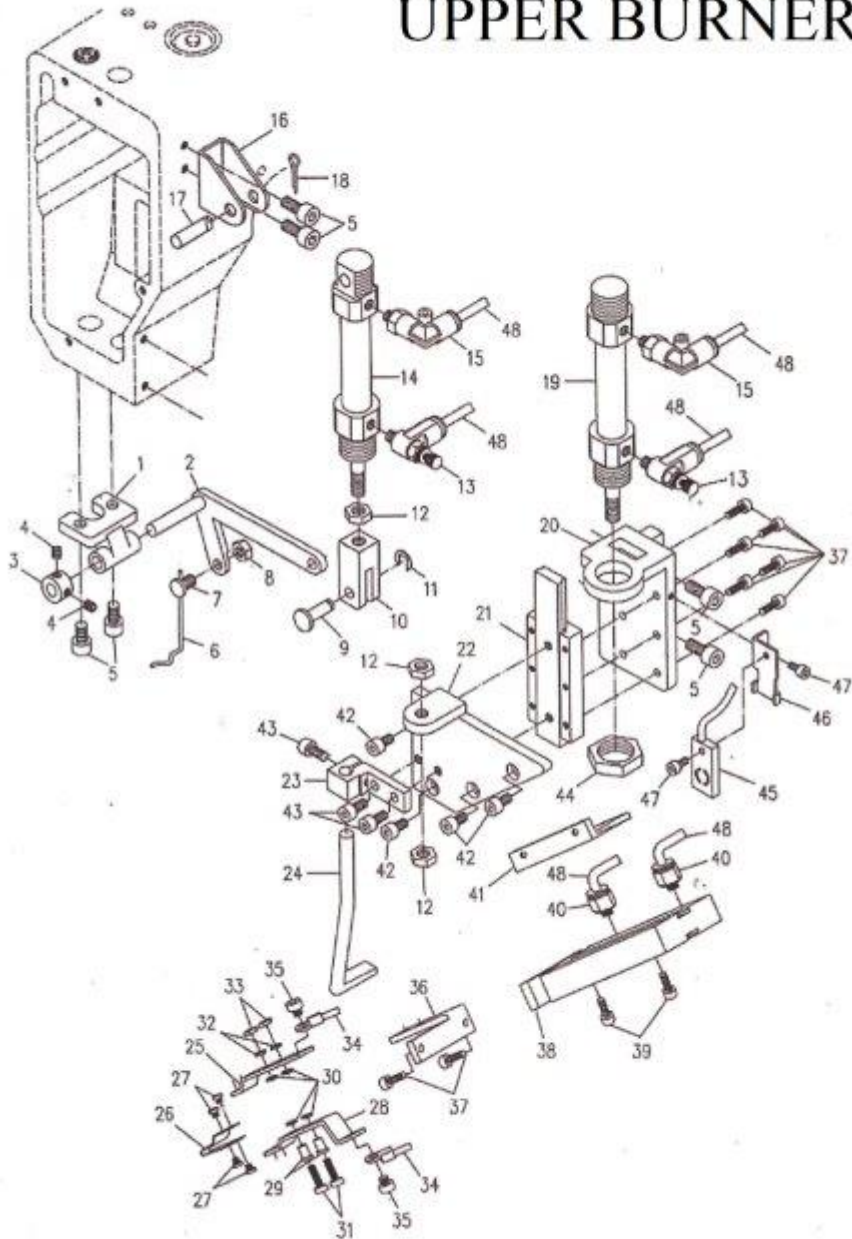

UPPER BURNER

1	TX1071101		1	
2	TX1071102		1	
3	TX1071103		1	
4	TX1071104		2	M4x4
5	TX1071105		6	M5x10
6	TX1071106		1	
7	TX1071107		1	
8	TX1071108		1	M5
9	TX1071109		1	204
10	TX1071110		1	204
11	TX1071111		1	#4
12	TX1071112		3	M8
13	TX1071113		2	M5004-M5
14	TX1071114		1	OC85 12x35
15	TX1071115		2	PL4-M5
16	TX1071116		1	221
17	TX1071117		1	221
18	TX1071118		1	#1.5
19	TX1071119		1	12x20
20	TX1071120		1	
21	TX1071121		1	
22	TX1071122		1	
23	TX1071123		1	
24	TX1071124		1	
25	TX1071125		1	
26	TX1071126		1	
27	TX1071127		4	M3x4
28	TX1071128		1	
29	TX1071129		2	
30	TX1071130		4	
31	TX1071131		2	M3x4
32	TX1071132		2	3
33	TX1071133		2	M3
34	TX1071134		2	
35	TX1071135		2	M4x4
36	TX1071136		1	
37	TX1071137		8	M3x10
38	TX1071138		1	TDA10x25
39	TX1071139		2	M3x20
40	TX1071140		2	PC4-m5
41	TX1071141		1	
42	TX1071142		4	M4x8
43	TX1071143		3	M4x10
44	TX1071144		1	M10x1.5
45	TX1071145		1	
46	TX1071146		1	
47	TX1071147		2	M3x8
48	TX1071148		6	#4

LOWER BURNER

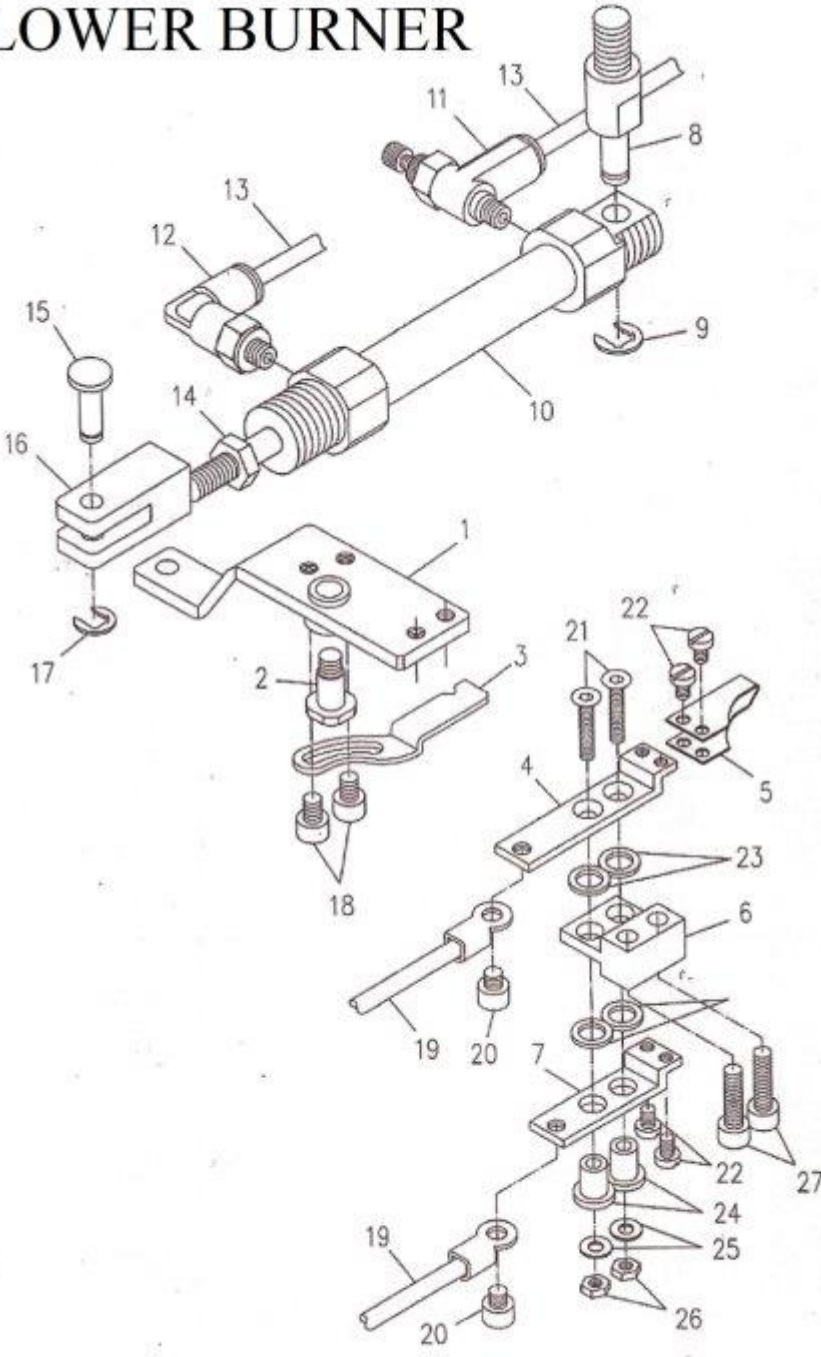

LOWER BURNER

1	TX1071201		1	
2	TX1071202		1	
3	TX1071203		1	
4	TX1071204		1	
5	TX1071205		1	
6	TX1071206		1	
7	TX1071207		1	
8	TX1071208		1	
9	TX1071209		1	#5
10	TX1071114		1	QC85 12x35
11	TX1071113		1	SC04-M5
12	TX1071115		1	PL4-M5
13	TX1071148		2	#4
14	TX1071112		1	#8
15	TX1071109		1	
16	TX1071110		1	
17	TX1071111		1	#4
18	TX1071218		2	M4x5
19	TX1071134		2	
20	TX1071135		2	M4x4
21	TX1071221		2	M3x4
22	TX1071127		4	M3x4
23	TX1071130		4	
24	TX1071129		2	
25	TX1071132		2	3
26	TX1071133		2	M3
27	TX1071227		2	M4x4

Appendix 1 level 1 parameter

Parameter	Function And Description	Setting Range	Unit	Remarks
P-1	max speed	50~ 800	rpm	
P-2	speed 1	100~ 800	rpm	
P-3	Speed 2	150~ 800	rpm	
P-4	speed 3	200~ 800	rpm	
P-5	trimming after urgentstop	1 Yes, 0 No		
P-6	top needle stop position	1~ 4319		
P-7	check frequency	15~ 45		
P-8	stretching time	150~ 1000		
P-9	presser foot put down time	150~ 500		
P-10	thread trim switch	0 off, 1on		
P-11	needle bar lift angle	-120--120		
P-12	winding speed	100~ 800	rpm	
P-13	back to origin speed	1~ 4		1,slow, 4 quick
P-14	empty feeding speed	1~ 9		1, slow , 9 quick
P-15	patterning speed	1~ 5		1, slow , 5 quick
P-16	foot up after Sew stop	0no 1 yes		
P-17	Air pressure detect switch	0 off 1 on		
P-18	Pressure testing of	0invariant 1negation		
P-19	Add Trim when NOP MOVE	0no 1yes		
P-20	pressure box up when trim	0no 1yes		
P-21	path of return origin 2	0 path 1 direction		
P-22	sweeping thread switch	0off 1on		
P-23	urgent stop switch polarity	0invariant 1negation		
P-24	Breakage detection switch	0 close 1 open		
P-25	thread loosing switch	0off 1on		
P-26	sweeping thread time	50---2000		
P-27	auto trim after sew end	0no 1yes		
P-28	perm down check(0-1)	0 1		
P-29	perm sensor polarity(0-1)	0 1		
P-30	Breakage detection polarity	0Unchanged 1Inverse		
P-31	thread trim	0later 1immediate		
P-32	pattern input	0manual 1scanned		
P-33	stopping position	0 origin 1 unoriginal		
P-34	bottom line detection switch	0off 1on		
P-35	cop latch length unit mm	1000~ 65000		
P-36	Dowel pin install location	0~ 800		
P-37	needle down position	0~ 800		

Appendix 2 level 2 parameter

Parameter	Function And Description	Setting Range	Unit	Remarks
P-1	x origin	-500000-----500000		
P-2	y origin	-500000-----500000		
P-3	thread trim open angle	0-----355		
P-4	thread release dev angle	160-----320		
P-5	Clamping solenoids PWM	10-----1000		
P-6	presser plate 1 solenoids pwm	10-----1000		
P-7	presser foot solenoids pwm	10-----1000		
P-8	presser plate 2 solenoids pwm	10-----1000		
P-9	x sensor polarity	0invariant---1negation		
P-10	y sensor polarity	0invariant---1negation		
P-11	y drive mode	50---250		
P-12	clamping open angle	0-----170		
P-13	needle stop position check	-300-----300		
P-14	count of pressure box signal	0-----4		
P-15	limiting speed	400-----2700		
P-16	Thread loose open time	1-----180		
P-17	pressurebox width check(mm)	-300-----300		
P-18	presser foot up time	50-----2000		
P-19	main shaft start time	40-----1000		
P-20	presserfoot max height	30-----200	mm	
P-21	z sensor polarity	0invariant---1negation		
P-22	foot motor rotation direction	0invariant---1negation		
P-23	pressure plate1 nature state	0down---1up		
P-24	pressure plate2 nature state	0down---1up		
P-25	pressure plate2 function	0---3		
P-26	X sewing range	500-12000	mm	
P-27	Y sewing range	400-10000	mm	
P-28	clamp close angle	1-350		
P-29	sweep thread	0clamp---1choose		
P-30	u origin	-800---800		
P-31	v origin	-800---800		
P-32	clamping cylinder status	0close---1open		
P-33	Foot Max Dynamic Height	50---120		
P-34	thread trim solenoids pwm	10---1000		
P-35	thread loose solenoids pwm	10---1000		
P-36	oil motor work time	1---60		
P-37	oil motor stop time	1---60		

Appendix 3 level 3 parameter

Parameter	Function And Description	Setting Range	Unit	Remarks
P-1	cutting speed	200-----500		
P-2	working/testing switch	0working',1testing		
P-3	material receipt motor start time	0-----60		
P-4	main shaft motor	0off-line 1online		
P-5	testing mode	0machine 1main shaft		
P-6	presser foot up speed	1-----6		
P-7	presserfoot up when FWD/BWD	0no',1yes		
P-8	Multiples of V and SV	0-----10		
P-9	machine type	0 9000G---1 3020G		
P-10	step motor type	1 8686 2 6060		
P-11	empty feeding time	10-----500		
P-12	stop patterning switch	0-----1		
P-13	z-axis origin	-3000-----3000		
P-14	z motor transmission ratio	0-----3000		
P-15	X motor transmission ratio	600000-----50000000		
P-16	Y motor transmission ratio	600000-----50000000		
P-17	stretch presser foot up time	40-----500		
P-18	change the needle time	150-----500		
P-19	motor rotation direction	0invariant 1negation		
P-20	max stitch length	127-----400		
P-21	x sv	75-----300		
P-22	x v	75-----300		
P-23	y sv	75-----300		
P-24	y v	75-----300		
P-25	pre heating time above perm	0-----80		
P-26	pre heating time down perm	0-----80		
P-27	waiting time before dropping down	0----20		
P-28	waiting time before into to	0----20		
P-29	keep time above perm	0----20		
P-30	keep time down perm	0----40		
P-31	waiting time before sweeping thread above	0----30		
P-32	time relative to sweeping thread above	-30----30		
P-33	-Y feeding sync time	-50---100		
P-34	-X feeding sync time	-50---100		
P-35	Y feeding sync time	-50---100		
P-36	X feeding sync time	-50---100		
P-37	feeding mode	0auto 1fixed		

8. Alarm description, possible cause and corrective action

The PSDA driver has various protective functions. When one of the protections is activated, the motor trips according to the timing chart, and the Servo Alarm Output (ALM) is turned off.

Actions to be taken after trip events

- After a trip event, the LED touch panel displays an alarm code no., and no Servo-ON occurs.
- Any trip status is cleared by keeping A-CLR (Alarm Clear Input) on for at least 120 ms after A-CLR off.
- The overload protection can be cleared by A-CLR at least 10 seconds after the occurrence of the event. If the control power connection between r and t is opened, the time limiting operation is cleared.
- The alarms mentioned above can also be cleared with the LED touch panel.

Notes: Protections marked with * cannot be cleared with A-CLR (Alarm Clear Input).

They should be cleared by turning the power off, removing the causes, and then turning the power on again

Code	Protection	cause	Corrective action
Err – 01	Over current	<p>The current flowing in the converter is larger than the specified value.</p> <ol style="list-style-type: none"> 1) The driver failed (due to defective circuits or IGBT parts). 2) Motor wires (U, V and W) are shorted. 3) Motor wires (U, V and W) are grounded. <p>Motor burned</p> <ol style="list-style-type: none"> 5) Poor connection of Motor wires 6) The relay for the dynamic brake is melted and stuck due to the frequent Servo-ON/OFF. 7) The motor is not compatible with the driver. 	<ol style="list-style-type: none"> 1) Disconnect the motor wires, and enter Servo-ON. If this trouble happens immediately, replace the driver with a new one (that is working correctly). 2) Check if the U, V and W wires are shorted at the connections. Reconnect them, if necessary. 3) Measure the insulation resistance between U/V/W and earth wire. If the resistance is not correct, replace the motor with a new one. 4) Measure the resistance between U, V and W. If they are unbalanced, replace the motor with a new one. 5) Check if the U/V/W connector pins are firmly secured with screws. Loosened pins should be fixed firmly. 6) Replace the driver with a new one. Do not start or stop the motor by entering Servo-ON or OFF. 7) Check the capacity of the motor and driver on the nameplate. If the motor is not compatible with the driver, replace it with a correct one.
Err – 02	Over voltage	The line voltage is larger than the specified	Measure the terminal-to-terminal

		<p>acceptable range, so that the P-N voltage of the converter is larger than the specified value, or the line voltage was raised by a condensive load or UPS (Uninterruptible Power Supply).</p> <ol style="list-style-type: none"> 1) The internal regenerative discharge resistor is disconnected. 2) The eternal regenerative discharge resistor is not suitable so that regenerative energy cannot be absorbed. 3) The driver (circuit) failed. 	<p>voltages (between R, S and T). Remove the causes. Feed a power of correct voltage.</p> <ol style="list-style-type: none"> 1) Measure the P-B2 resistance of the driver using a circuit tester. If it read .Aa, the connection is broken. Replace the resistor. Insert an external regenerative discharge resistor between the P and B1 terminals. . 2) Use a resistor having the specified resistance for specified Watt. 3) Replace with a new driver (that is working correctly for another axis).
Err – 03	Under voltage	<p>The P-N voltage of the main power converter is lower than the specified value during servo-ON.</p> <ol style="list-style-type: none"> 2) The main power line voltage is too low, an instantaneous outage occurred, the power source is too small, the main power is turned off, or the main power is not fed. 3) Too small power source: the line voltage dropped due to the inrush current at power On. 	<p>Measure the terminal-to-terminal voltages (between R, S and T).</p> <ol style="list-style-type: none"> 1) Increase the capacity of the main power or replace it with a larger one. Or remove the causes of the failure of the magnetic contact, and then restart the power source. 2) Increase the capacity of the main power. For the required capacity. 3) Correct the phase (R, S and T) connections of the main power. 4) Check the timing of power-on (for both the main power and control power).
Err – 04	Over heat	<p>The radiator is heated up to exceed the limit temperature. The power elements of the driver are overheated. Overload.</p>	<p>The heat sink is heated up to exceed the limit temperature. The power elements of the driver are overheated. Overload.</p>
Err – 06	Encoder error	<ol style="list-style-type: none"> 1. Encoder is damaged. 2. Encoder is not well connected with the driver. 	<ol style="list-style-type: none"> 1. Check encoder. 2. Check wiring.
Err – 07	EEPROM read / write error	<ol style="list-style-type: none"> 1) The data contained in the parameter storage area of the EEPROM is broken, so erroneous data is retrieved. 2) The check code of the EEPROM is broken, so erroneous data is retrieved. 	<p>Set all the parameters again. If this error occurs frequently, the driver may have been broken. Replace the driver with a new one. Return the old driver to the sales agent for repair.</p> <p>The driver may have been broken. Replace the driver with a new one. Return the old driver to the sales agent for repair.</p>
Err – 08	Parameters initiation fault	<ol style="list-style-type: none"> 1) Encoder cable is not connected. 2) Encoder cable may be broken. 	<ol style="list-style-type: none"> 1) Re-connect encoder cable. 2) Check encoder cable.
Err-10	Baud rate error	<p>The driver checked wrong baud rate setting, and changes the setting to 57600BPS automatically.</p>	<p>Reset the baud rate according to parameter table.</p>
Err – 11	position error too large	<ol style="list-style-type: none"> 1) The motor velocity exceeds the specified limit. 2) The position error pulse is larger than Pr63 (position error limit). The motor operation does not respond to the commands. 	<ol style="list-style-type: none"> 1) Decrease the target speed (command values). 2) Adjust the electronic gear ratio so that the frequency of the command pulse is 500 kpps or less. If an overshoot occurs, readjust the gains. <p>Correct the encoder wiring per the wiring diagram. Check whether the motor</p>

			operates per the position command pulse or not. See the torque monitor to check if the output torque is saturated. Readjust the gains. Maximize the value of Pr12 (torque limit set-up). Correct the encoder wiring per the wiring diagram. Increase the acceleration and deceleration time. Reduce the load and velocity.
Err – 12	CW over-travel limits	The CW over-travel limits is not Active.	Check the switches, wires and power supply that constitute the circuits... Check the value of Pr59. Correct the wiring, if necessary.
Err – 13	CCW over-travel limits	The CCW over-travel limits are not Active.	
Err – 14	Overload	<p>Overload protection is activated via the specified time limiting operation when the integration of a torque command exceeds the specified overload level. Caused by a long operation with a torque that exceeds the specified torque limit.</p> <ol style="list-style-type: none"> 1) Long operation with more load and Torque than the rating. 2) Vibration or hunting due to incorrect gains. Cause vibration and/or abnormal sound. 3) Motor wires connected wrong or broken 4) The machine is hit against a heavy hing, or suddenly becomes heavy in operation. The machine is en tangled. 5) The electromagnetic brake is ON. 6) In a system of multiple drivers, some motors are wired incorrectly to other axis. 	<p>Monitor the torque (current wave) using an oscilloscope to check whether the torque is surging or not. Check the load factor and overload alarm messages.</p> <ol style="list-style-type: none"> 1) Increase the capacity of the driver and motor. Lengthen the ramp time of acceleration/ deceleration. Reduce the motor load. 2) Readjust the gains. 3) Correct the motor wiring per the wiring diagrams. Replace cables. 4) Free the machine of any tangle. Reduce the motor load. 5) Measure the voltage at the brake wiring connections. Turn off the brake. 6) Correct the motor and encoder wiring to eliminate the mismatching between the mo.
Err – 15	Module Fault		If power on again and the fault is still existence, please replace with a new driver.
Err – 16	Energy witching timeOut	Servo drive works in the energy consumption braking state for a long time.	<ol style="list-style-type: none"> 1) Test the servo drive R,S,T input terminal voltage is too high. 2) Check whether the energy consumption brake resistance is normal and the terminals are in good contact. 3) Check whether the Pr6B and Pr6C parameter values are set too small.
Err – 18	Encoder signal anomaly	<ol style="list-style-type: none"> 1) Encoder signal receives interferences. 2) Encoder receives exception information. 	<ol style="list-style-type: none"> 1) Check whether the encoder wiring is good and reliable. 2) Check the encoder cable wiring is reasonable (such as with the motor power cord or other large current cable wrapped together). 3) Motor encoder damage.
Err – 19	Error of current detection	Detection of zero current anomaly.	<ol style="list-style-type: none"> 1) To confirm whether the current zero drift is too large. 2) According to the manufacturer to guide the implementation of automatic zero calibration.
Err – 20	Motor over speed	<ol style="list-style-type: none"> 1) Motor speed exceeds the maximum limit.. 2) Abnormal motor operating speed. 	<ol style="list-style-type: none"> 1) Check whether the value of the Pr73 parameter is too small for the limit value of the speed limit.

			<ul style="list-style-type: none"> 2) Check whether the value of the Pr65 parameter is too small. 3) Detection of UVW sequence corresponding to the drive motor definition is correct. 4) Detection of UVW sequence corresponding to the drive motor definition is correct.
Err – 21	Speed windage oversized alarm	<ul style="list-style-type: none"> 1) Abnormal motor operating speed. 2) Motor rotation blockage. 3) Motor UVW connection error, cause the motor can not normally start. 	<ul style="list-style-type: none"> 1) Check motor wiring is correct. 2) Check whether the load is normal.
Err – 22	Encoder communication data error	Encoder communication data received interference cause communication check is not correct.	<ul style="list-style-type: none"> 1) Check whether the connection between the FG terminal and the motor is correct.. 2) Check whether the load is normal.
Err – 24	Motor overheating	Motor overheating protector action.	<ul style="list-style-type: none"> 1) Improved motor cooling and cooling conditions. 2) False alarm caused by bad contact of motor encoder line.
Err – 25	Motor holding brake abnormality	Detection of the motor running in the early warning of the current state for long time.	<ul style="list-style-type: none"> 1) Motor holding brake is not released. 2) Motor holding brake power supply abnormal. 3) Motor holding brake damage. 4) Power selection of motor is too small. 5) Load is too heavy or abnormal. 6) Current anomaly detection parameter (Pr6E,Pr6F) parameter value setting is too small.
Err – 31	Software over current protection	<ul style="list-style-type: none"> 1) Load inertia mutations, such as the motor from the high-speed emergency stop. 2) Motor connection or motor internal fault. 3) Short circuit of electric motor. 	<ul style="list-style-type: none"> 1) Check whether the load control circuit is faulty. 2) Check whether the motor is faulty, such as wiring and grounding.. 3) Is the motor short circuit.