



GLOBAL

333-Series

M = 333-D

B = 333-LH

M-D3 = 333-AUT

B-D3 = 333-LH-AUT

Instruction & parts Manual

www.globalsew.com

info@globalsew.com

CONTENTS

1. PRECAUTIONS BEFORE STARTING OPERATION.....	1
2. MAIN SPECIFICATIONS.....	1
3. PREPARATION AND LUBRICATION.....	2
4. REPLACE NEEDLES.....	2
5. NEEDLE, THREAD AND MATERIAL TO BE SEWN.....	3
6. THREADING.....	3
7. WINDING ADJUSTMENT.....	3
8. SET STITCH LENGTH AND REVERSE FEEDING.....	4
9. POSITION PRESSER BAR.....	4
10. ADJUST THE PRESSURE OF PRESSER FOOT.....	4
11. ADJUST THREAD TAKE-UP SPRING.....	4
12. ADJUST THREAD TENSION.....	5
13. ADJUST THREAD GUIDE AND THREAD TENSION.....	5
14. TIME NEEDLE TO ROTATING HOOK.....	6
15. REPLACE ROTATING HOOK.....	7
16. ADJUST THE HEIGHT OF FEED DOG.....	7
17. ADJUST THE POSITION OF FEED DOG.....	8
18. TIME FEED MOTION TO NEEDLE MOTION.....	8
19. ADJUST OPENING TIME OF THE TENSION DISCS.....	9
20. LUBRICATION ADJUSTMENT.....	9
21. REGULAR CLEANING.....	10
SPECIAL INSTRUCTION OF GC128-D3.....	10
22. ADJUSTMENT OF NEEDLE BAR STOP POSITION.....	10
23. CONNECTION OF THE SEWING MACHINE AND CONTROL BOX.....	11
24. REVERSE SEWING.....	11
25. THREAD WIPER.....	11
26. PEDAL OPERATION.....	12
27. ADJUSTMENT OF PEDAL TOE DOWN PRESSURE, AND HEELING PRESSURE.....	12

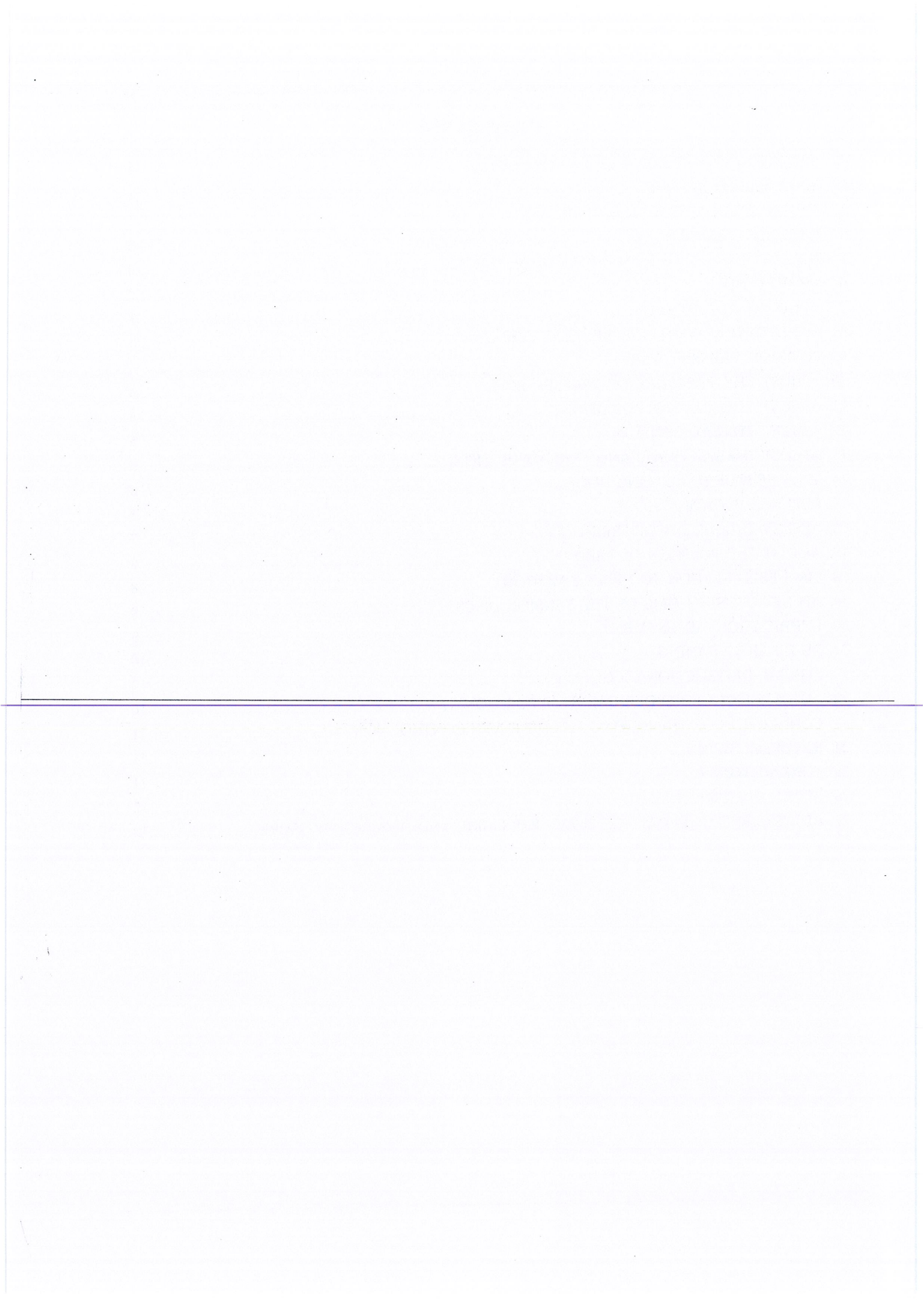

1. PRECAUTIONS BEFORE STARTING OPERATION

1) Safety Precautions:

- (1) When turning the power on, keep your hands and fingers away from the area around/under the needle and the area around the balance wheel.
- (2) Power must be turned off when the machine is not in use, or when the operator leaves the seat.
- (3) Power must be turned off when tilting the machine head, installing or removing the "V" belt, adjusting the machine, or when replacing.
- (4) Avoid placing fingers, hairs, bars etc., near the balance wheel, "V" belt, bobbin winder balance wheel, or motor when the machine is in operation.
- (5) Do not insert fingers into the thread take-up cover, under/around the needle, or balance wheel when the machine is in operation.
- (6) If a belt cover, finger guard, eye guard are installed, do not operate the machine without these safety devices.

2) Precautions before Starting Operation:

- (1) If the machine's oil pan has an oil sump, never operate the machine before filling it.
- (2) If the machine is lubricated by a drop oiler, never operate the machine before lubricating.
- (3) When a new sewing machine is first turned on, verify the rotational direction of the balance wheel with the power on. (The balance wheel should rotate counter-clockwise when viewed from the balance wheel)
- (4) Verify the voltage and (single or three) phase with those given on the machine nameplate.

3) Precautions for Operating Conditions:

- (1) Avoid using the machine at abnormally high temperature (35°C or higher) or low temperature (5°C or lower)
- (2) Avoid using the machine in dusty conditions.

2. MAIN SPECIFICATIONS

Item	M	M-D3	H	H-D3	B	B-D3
Material	Light		Medium-Heavy			
Max. sewing speed	5000 rpm		3500 rpm		3000 rpm	
Stitch length	0-5mm	0-4mm	0-8mm	0-7mm	0-8mm	0-7mm
Needle bar stroke	31.8mm			35mm		
Presser	By hand	6mm				
	By knee	13mm				
Needle	DB×1 #14			DB×1 #22		
Reversing mechanism		○		○		○
Trimming mechanism		○		○		○
Touch back mechanism		○		○		—

3. PREPARATION AND LUBRICATION

1) Cleaning the machine

Before leaving the factory, the machine parts are coated with rust-preventive grease, which may be hardened and contaminated by dust during storage and shipment. This grease must be removed with gasoline.

2) Examination

Though every machine is confirmed by strict inspection and test before leaving the factory, the machine parts may be loose or deformed after long distance transportation with jolt. A thorough examination must be performed after cleaning the machine. Turn the balance wheel to see if there is running obstruction, parts collision, uneven resistance or abnormal noise. If these exist, adjustment must be made accordingly before run-in operation.

3) Oiling (Fig.1)

(1) Required amount of oil

Line (A) on the oil reservoir: Max. Oil level

Line (B) on the oil reservoir: Min. Oil level

If oil level goes down under line (B), oil cannot be distributed to each part of the machine, thus causing the parts a seizure.

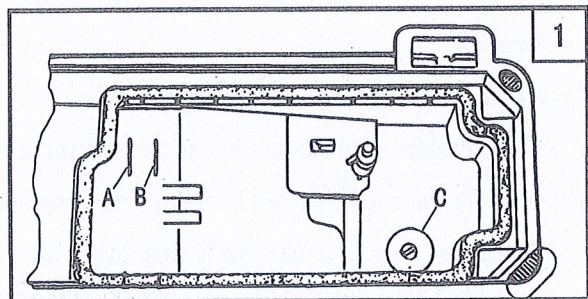

(2) Replenishing

Always use only No. 18 special machine oil for high speed sewing. Be sure to replenish oil to line (A) before starting operation.

(3) Replacing oil

To replace oil, remove screw (C) to drain oil. After completely draining off oil, clean the oil reservoir and securely tighten screw (C), then fill the reservoir with fresh oil.

4. REPLACE NEEDLES (Fig.2)

Turn the balance wheel to lift needle bar to the upper end of its stroke. Loosen needle clamp screw (A). While keeping the long groove of the needle leftward fully insert the needle shank up to the bottom of the needle socket. Then tighten needle clamp screw (A).

Note: Fig. (b): insufficient insertion.

Fig. (c): wrong direction of long groove.

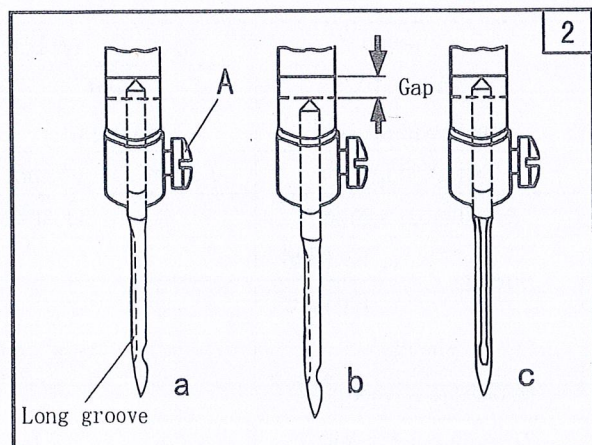

5. NEEDLE, THREAD AND MATERIAL TO BE SEWN

Needle Size	Thread Number	Material
No.9	No.100- No.80	crepe, georgette, organdie
No.11	No.80- No.60	silk, muslin, poplin
No.14	No.60- No.50	cotton, light, woolen
No.16	No.50- No.30	woolen, tarpaulin, thin leather

6.THREADING (Fig.3)

To thread the needle thread, raise needle bar to the upper end of its stroke, lead the thread from spool and perform threading as shown in Fig.3. To draw the bobbin thread, hold the end of the needle thread and turn the balance wheel to lower the needle bar and then to lift it to its highest position. Pull the needle thread and the bobbin thread is drawn up. Put the ends of needle thread and bobbin thread frontward under presser foot.

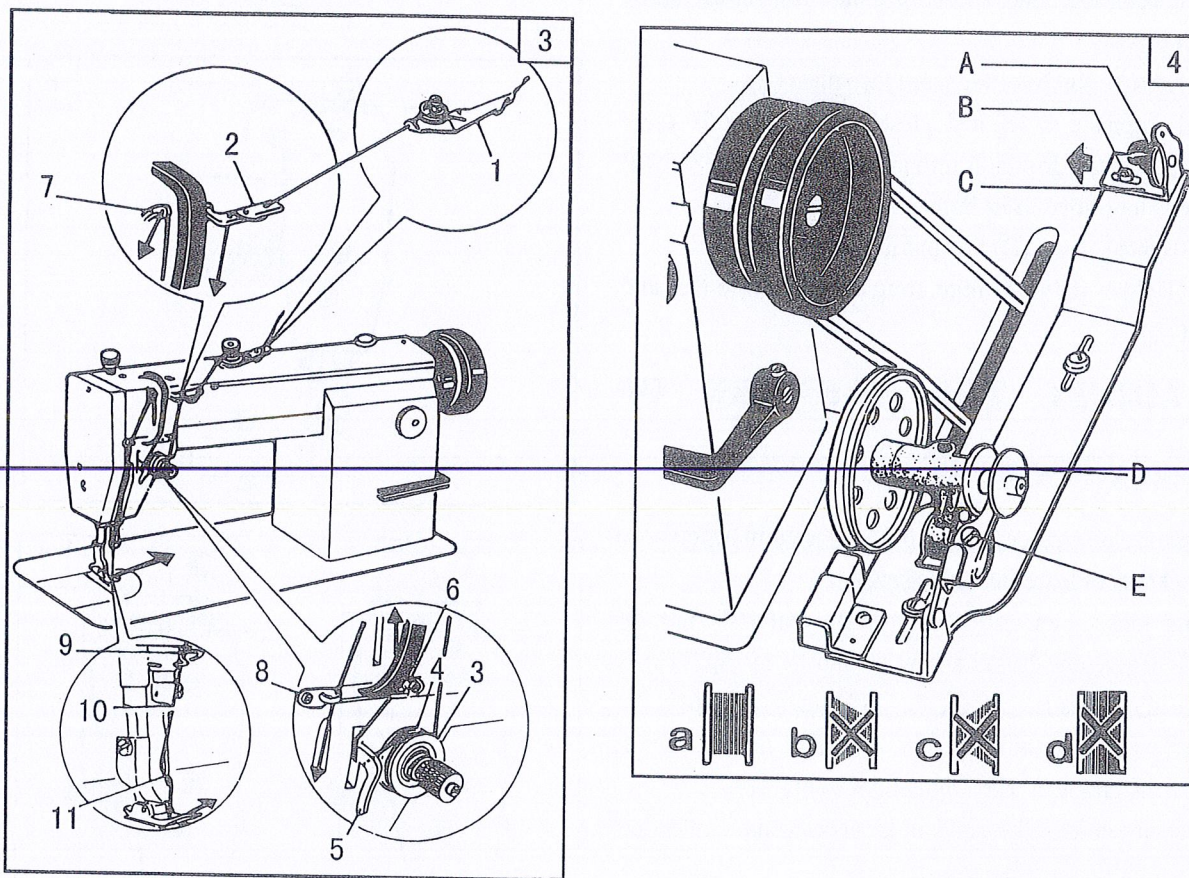

7. WINDING ADJUSTMENT (Fig.4)

1) The wound bobbin thread should be neat and tight, if not, adjust the winding tension by turning tension stud nut (A) of bobbin winder tension bracket.

Note: nylon or polyester thread should be wound with little tension; otherwise, bobbin (D) might break or deform.

2) When the wound thread layer does not present a cylindrical shape as shown in Fig.4 (a), loosen set screw (B) of bobbin winder tension bracket and slide bracket (C) leftward or rightward. If thread is wound as shown in Fig.4 (b), move the bracket rightward, but if thread is wound as shown in Fig.4 (c), move the bracket leftward.

After adequately positioning the bracket, tighten set screw (B).

3) Do not overfill the bobbin. The optimum length of thread will fill about 80% of bobbin capacity. This can be adjusted by adjusting screw (E) of bobbin winder stop latch.

8. SET STITCH LENGTH AND REVERSE FEEDING (Fig.5)

1) Stitch length can be set by turning dial (A).

2) The figures on face (B) of dial show stitch length in mm.

3) Reverse feeding starts when reverse feed lever (C) is depressed, and the machine will feed forward again if reverse feed lever (C) is released.

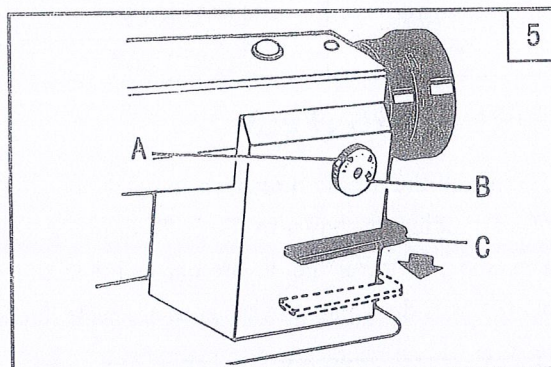

9. POSITION PRESSER BAR (Fig.6)

1) Loosen lock nut (E) and pressure regulating thumb screw (A).

2) Remove Rubber Plug from face plate (B).

3) Loosen screw (C) and adjust the position of Presser Bar till the presser foot is 6 mm above the throat plate will the presser foot lifted to its highest.

4) Tighten screw (C) and put in the rubber plug.

5) Tighten pressure regulating thumb screw (A) and lock nut (E).

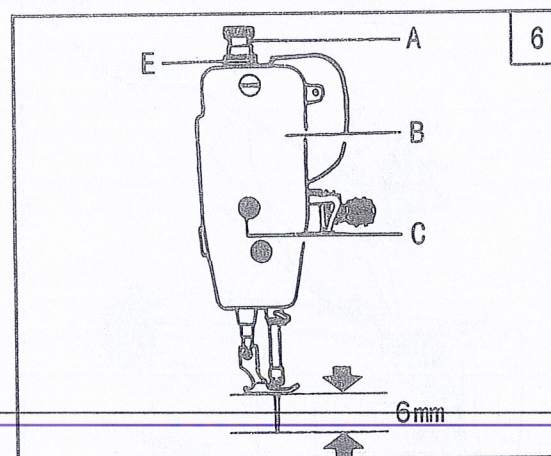

10. ADJUST THE PRESSURE OF PRESSER FOOT (Fig.7)

Pressure of presser foot is to be adjusted in accordance with thickness of materials to be sewn.

First loosen lock nut (A). For heavy materials, turn the pressure regulating thumb screw as shown in Fig.7 (a) to increase the pressure, while for light materials, turn the pressure regulating thumb screw as shown in Fig.7 (b) to decrease the pressure. Then tighten lock nut (A).

The pressure of presser foot is recommended to be less as long as normal feeding is ensured.

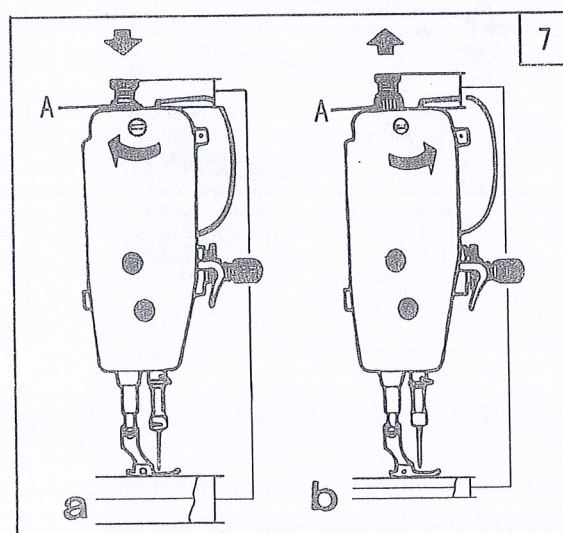

11. ADJUST THREAD TAKE-UP SPRING (Fig.8, 9)

1) Adjusting the thread take-up spring tension

Loosen set screw (A), turn tension stud (B) clockwise to increase the spring tension, or turn the stud counter-clockwise to decrease the spring tension. After the adjustment, be sure to tighten set screw (A). The thread take-up spring tension should be about 30g. To attain this, First loosen set screw (A), turn tension stud (B) counter-clockwise to decrease the tension of thread take-up spring (C) to zero, then turn tension stud (B)

clockwise until spring (C) comes to the notch of thread tension regulating bushing, and again turn tension stud (B) halfway back (counter-clockwise) After the adjustment, tighten set screw (A).

2) Adjusting the thread take-up spring stroke

Loosen set screw (B), turn stud (C) clockwise to increase the stroke or turn stud (C) counter-clockwise to decrease the stroke. After the adjustment, tighten set screw (B).

Before leaving the factory, the thread take-up spring has properly been adjusted. Readjustment is needed only in the case of special material or special thread.

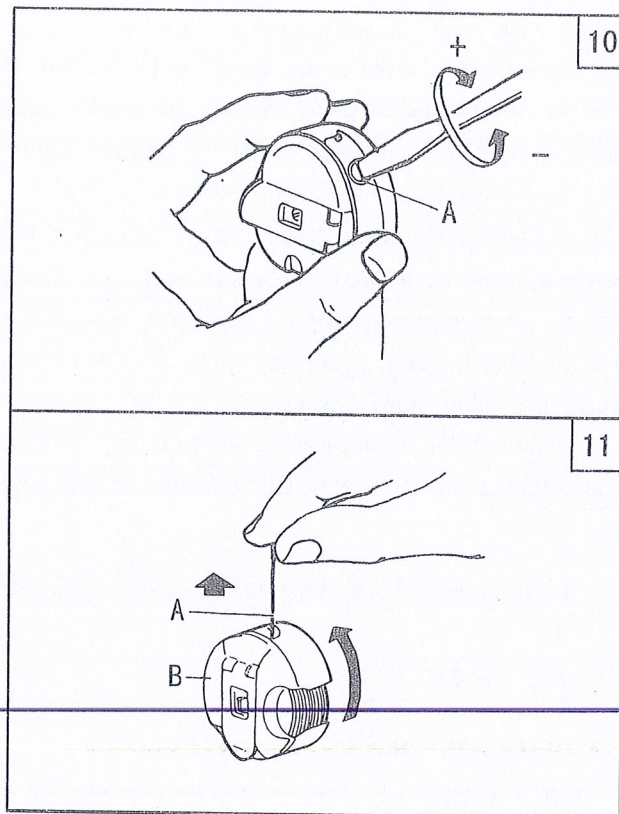
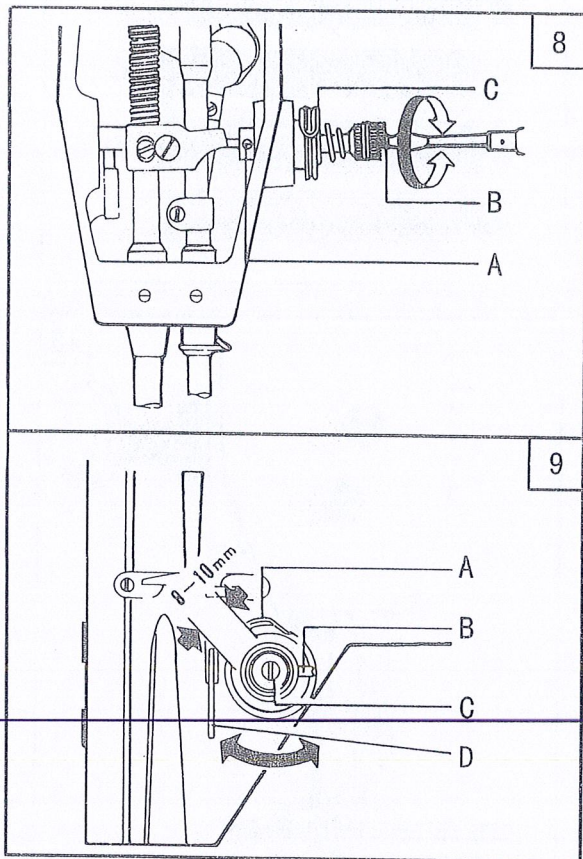

12. ADJUST THREAD TENSION (Fig.10, 11)

In principle, thread tension is to be adjusted in accordance with materials, thread and other factors.

In practice, thread tension is adjusted according to the stitches obtained. The needle thread tension should be adjusted with reference to the bobbin thread tension. Turn tension spring regulating screw (A) of bobbin case clockwise for more tension, or turn the screw counter-clockwise for less tension.

It is common practice to test the bobbin test the bobbin thread tension as shown in Fig.11. Hold the end of the thread from delivery eye. If the bobbin case is falling slowly, the proper tension is obtained. The needle thread tension can be adjusted by setting (1) the take-up spring tension, (2) the thread take-up spring stroke and (3) tension spring. All these adjustments will be described in the following.

13. ADJUST THREAD GUIDE AND THREAD TENSION (Fig.12, 13)

The position of the thread guide affects stitch tightness and therefore must be adjusted according to sewing materials and sewing conditions.

Thread guide position	1	2	3
	Leftward	Center	Rightward
Material weight	Heavy	Medium	Light

Fig.12 shows different stitch forms. Normal stitch form should be as shown in Fig.12 (a). When abnormal stitches cause puckering and thread break-age, the tension of needle thread and bobbin thread must be adjusted accordingly.

1) In case needle thread tension is too strong or bobbin thread tension is too weak, as shown in Fig.12 (b), turn the thumb nut counter-clockwise to decrease the needle thread tension, or tighten the tension spring regulating screw of bobbin case to increase the bobbin thread tension (Fig.13)

2) In case needle thread tension is too weak or bobbin thread tension is too strong, as shown in Fig.12 (c), turn the thumb nut clockwise to increase the needle thread tension, or loosen the tension spring regulating screw of bobbin case to decrease the bobbin thread tension.

3) In case of the stitch forms as shown in Fig.12 (d) and (e), adjustments can be made with reference to the above means.

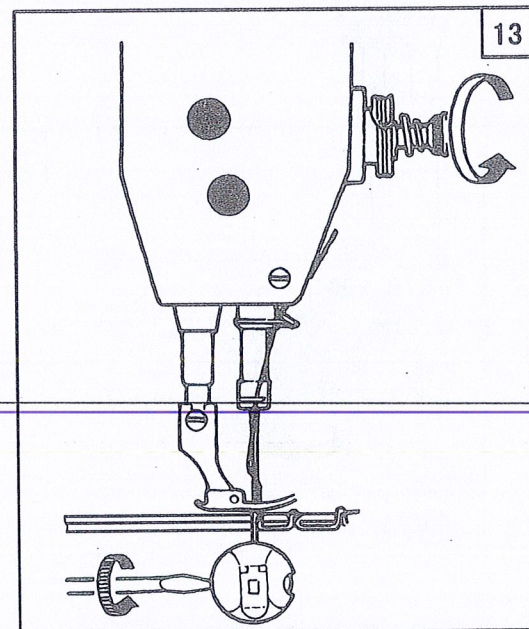
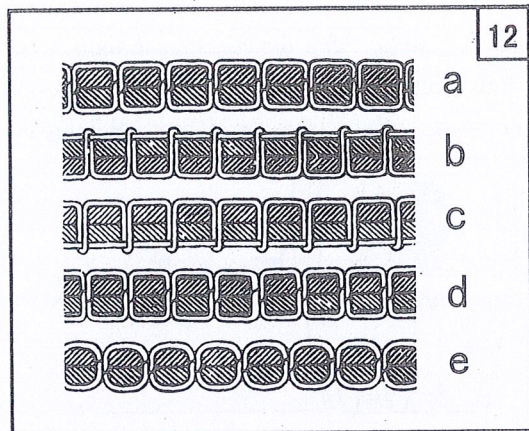

14. TIME NEEDLE TO ROTATING HOOK

(Fig. 14, 15, 16, 17)

1) Adjusting the needle position (Fig.14)

(1) Turn balance wheel by hand to bring needle bar (C) to the lowest position of its stroke.

(2) Remove rubber plug from face plate (A).

(3) Loosen set screw (B) of needle bar adaptor.

(4) Move needle bar (C) vertically to adjust needle timing.

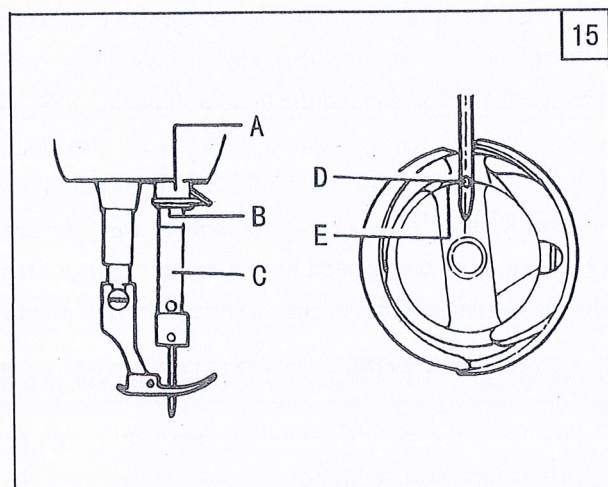
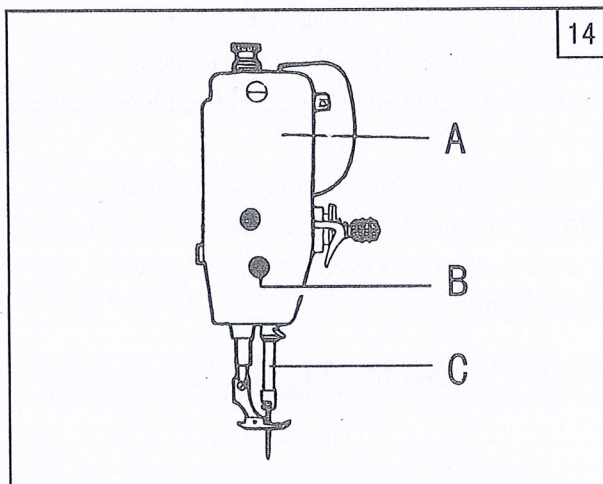

(5) After the adjustment, tighten set screw (B) and put in the rubber plug. The standard needle timing (Fig.15) is to align timing mark (B) on the needle bar and the bottom of needle bar bushing (A) and meanwhile align the inner surface (E) of the hook and the center of needle eye (D) when the needle bar gets down to its lowest position.

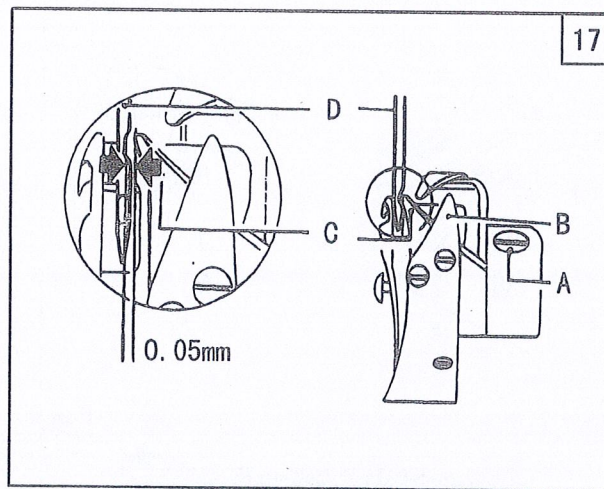
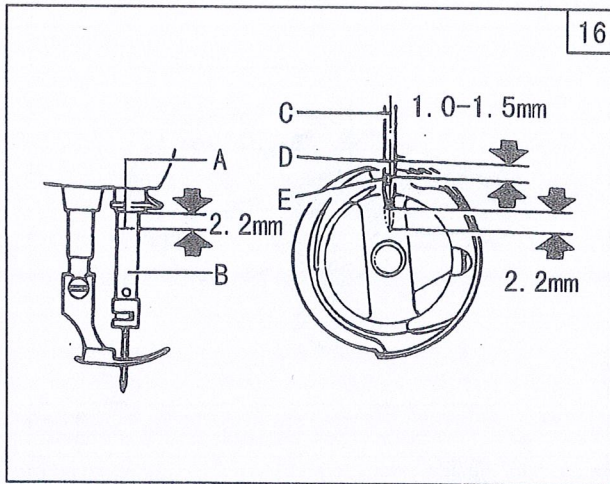

2) Adjusting the hook point timing

Timing of needle motion to rotating hook motion has a great effect on sewing performance. The standard hook point timing (Fig 16) is to align hook point (D) and needle centerline (C) when needle bar (B) is lifted by 2.2mm from the lower end of its stroke. Besides, hook point (D) should be 1.0-1.5mm above the upper end of needle eye (E).

When adjusting the hook point timing, also notice that the clearance between the bottom of needle notch and hook point (C) should be approx. 0.05mm (Fig 17)

15. REPLACE ROTATING HOOK (Fig.18)

- 1) Lift needle bar to the highest position of its stroke.
- 2) Remove throat plate, take down needle and bobbin case.
- 3) Loosen screw (C) of hook positioner and take down hook positioner (A).
- 4) Loosen two screw (D) of rotating hook.
- 5) Turn the balance wheel to raise feed bar to its highest position, then take down the rotating hook by turning it away from feed bar.
- 6) Installing the hook can be done in reverse sequence. Note that needle (B) and the convex surface of hook positioner (A) should align with a clearance of 0.5-0.7mm between them.

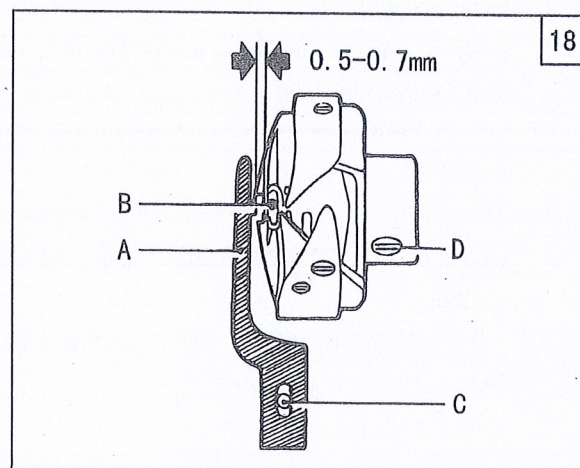

16. ADJUST THE HEIGHT OF FEED DOG (Fig.19, 20)

- 1) Turn the balance wheel until feed dog is lifted to its highest position from throat plate surface.

- 2) Loosen screw (A) of feed lifting rock shaft crank right (See Fig.19, b)
- 3) Move feed bar (B) in the direction shown by the arrow in Fig.19 (a) to adjust the height of the feed dog. The standard height of feed dog is that the top of feed dog is 0.8mm above throat plate surface (B).
- 4) After the adjustment, be sure to tighten screw (A).

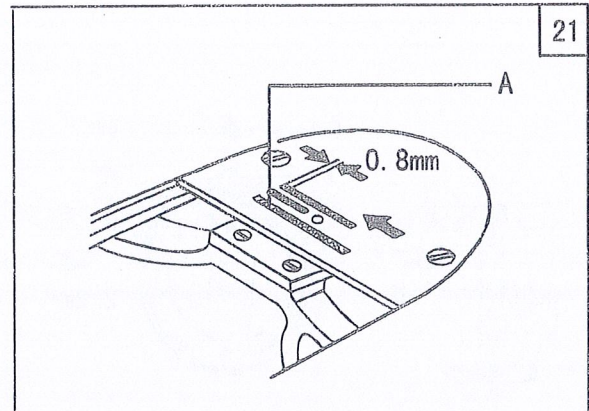
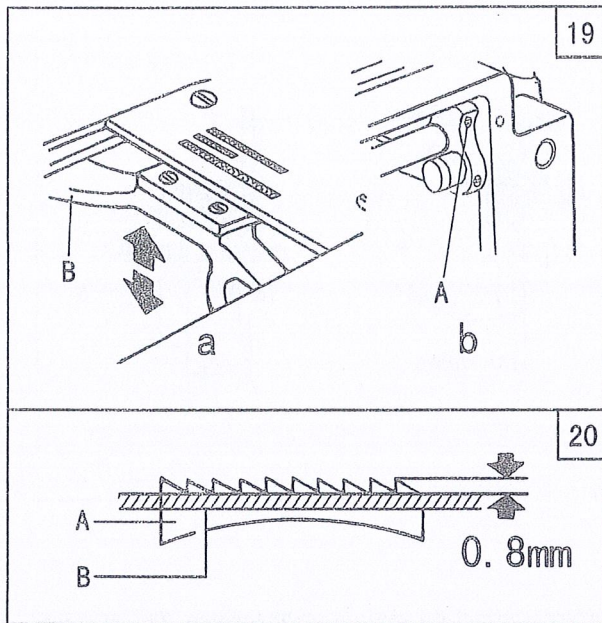

17. ADJUST THE POSITION OF FEED DOG (Fig.21, 22)

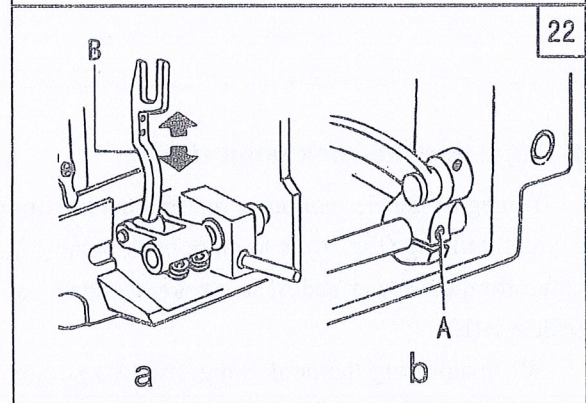

The standard position of feed dog is that the clearance between the front end of the throat plate slot and the first tooth of the fully advanced feed dog is 0.8 mm, as shown in Fig.21.

- 1) Fully advance the feed dog toward the front end of the throat plate slot.
- 2) Loosen feed rock shaft crank screw (A). See Fig.22 (b).
- 3) Move feed bar (B) in the direction shown by the arrow in Fig. 22 (a) to adjust the feed dog position.
- 4) After the adjustment, be sure to tighten Screw (A).

18. TIME FEED MOTION TO NEEDLE MOTION (Fig.23, 24)

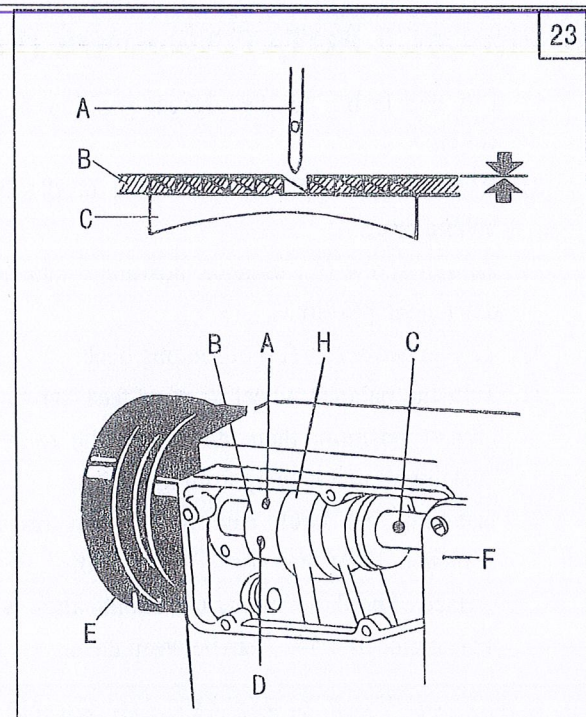

The standard timing of feed motion to needle motion is that the top of feed dog (C) is flush with throat plate surface (B) when the point of needle (A) reaches throat plate surface (B). (Fig.23.)

If feed motion is not timed to needle motion, adjust as follows (Fig.23 and Fig.24).

- 1) Remove arm side cover (F).
- 2) Loosen set screws (A) and (D) of feed and feed lifting eccentric.

3) Hold feed and feed lifting eccentric (B) and turn balance wheel (E) slowly until the upper edge of arm shaft oil hole (C) aligns with the lower edge of reference hole (G) of feed and feed lifting eccentric.

4) Leave a clearance of 0.3-0.5mm between feed and feed lifting eccentric (B) and eccentric sleeve (H), then tighten set screws (A) and (D).

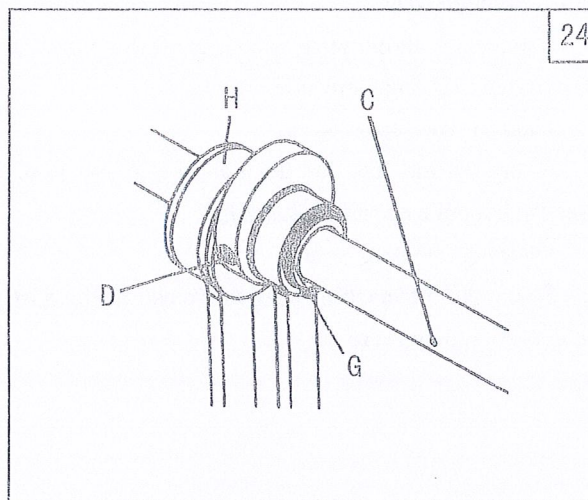

19. ADJUST OPENING TIME OF THE TENSION DISCS (Fig.25)

Within the presser foot lift range of 2-7mm opening time of the tension discs can be adjusted as follows:

- 1) Remove the rubber plug from the back of arm and loosen screw (A) of knee lifter lever (left).
- 2) Move the tension releasing cam leftward for earlier opening or rightward for later opening. It will facilitate the adjustment to put under the presser foot a block as thick as the presser foot lift.

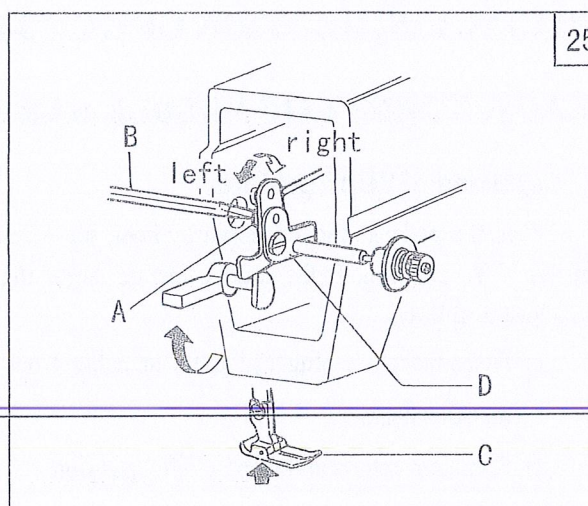

20. LUBRICATION ADJUSTMENT (Fig.26)

Adjusting the lubrication of rotating hook.

Oil adjusting screw (A) can adjust the lubrication of the rotating hook as follows:

- (1) Turn oil adjusting screw (A) clockwise to increase oil and turn oil adjusting screw (A) counter-clockwise to decrease oil.
- (2) Oil adjusting screw (A) adjusts oil amount within 5 turns. When oil adjusting screw (A) is fully tightened, oil amount is maximum.

(3) Readjustment depends on temperature, sewing speed and the like. In practice, oil amount can be judged as follows: remove the throat plate and place a piece of paper on instead. run the machine for about 20 seconds, then check the oil splashed on the paper.

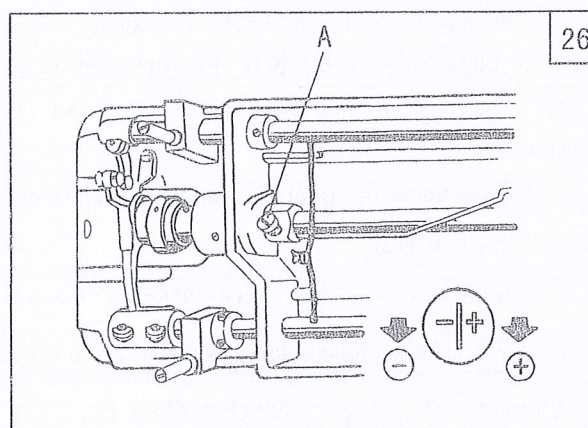

21. REGULAR CLEANING (Fig.27)

1) Cleaning feed dog

Remove the throat plate and clear off the dust and lint between feed dog tooth slots.

2) Cleaning rotating hook

Swing out the machine head and clean the hook. Wipe the bobbin case with soft cloth.

3) Cleaning oil pump, screen

Swing out the machine head and clear off the dust and dirt on oil pump screen.

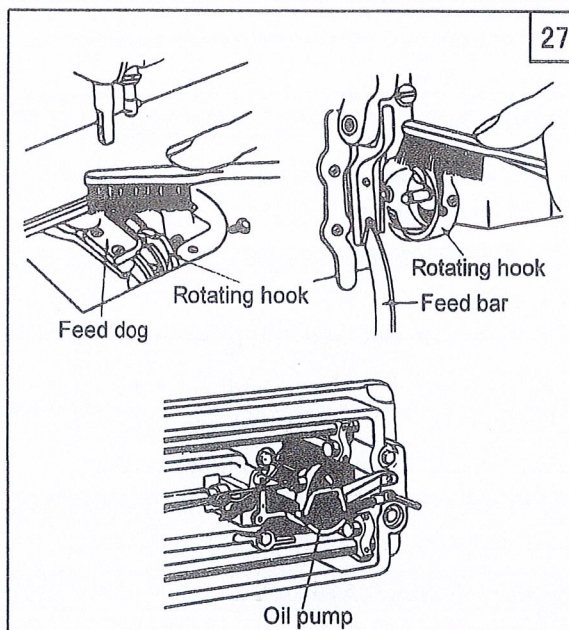

SPECIAL INSTRUCTION OF GC128-D3

22. ADJUSTMENT OF NEEDLE BAR STOP POSITION (Fig. 28, 29)

1) Adjusting of "Up" position

When the pedal is kicked down by heel, the machine stops at "UP" position. If the marks deviate larger than 3 mm adjust as follows:

- (1) Disconnect the plug (12 pins) of cable from the machine head.
- (2) Run the machine and stop at "UP" position.
- (3) While holding the balance wheel insert the "adjusting tool" in the hole A, then remove the tool.

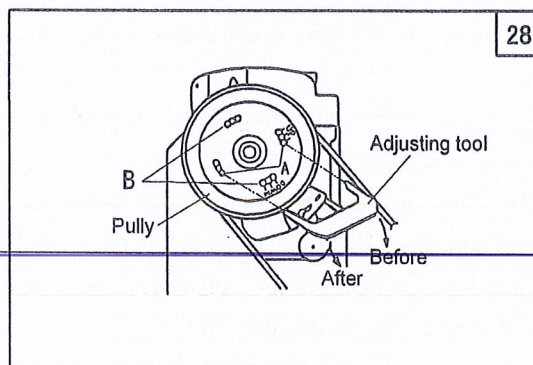

2) Adjusting of "DOWN" position

Set the machine stops at "DOWN" position. When the pedal is kicked down by hell, the machine stops as "DOWN" position. If the marks deviate larger than 3 mm adjust as follows:

- (1) Disconnect the plug (12 pins) of cable from the machine head.
- (2) Run the machine and stop at "DOWN" position.
- (3) While holding the balance wheel insert the "adjusting tool" in the hole B, then remove the tool.

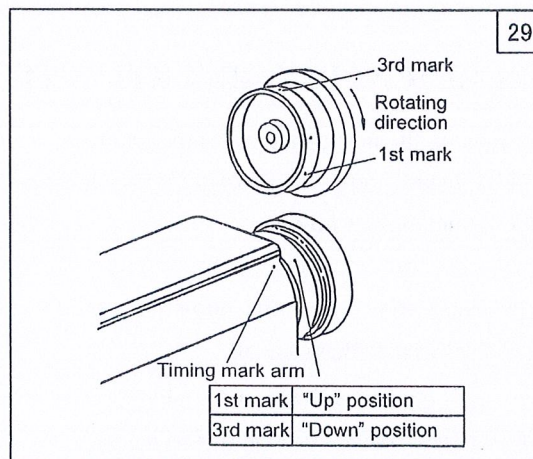

- 3) Confirm the stop operation then the plug (12 pins) coming from the machine head into the receptacle.

23.CONNECTION OF THE SEWING MACHINE AND CONTROL BOX

Wire the units as shown Fig.30

Caution: For safety, always turn the power switch OFF and wait for the panel [PWD.OF] (displayed for approx. 10 seconds) before connecting or disconnecting the plugs. This [PWR.OF] display is not an error.

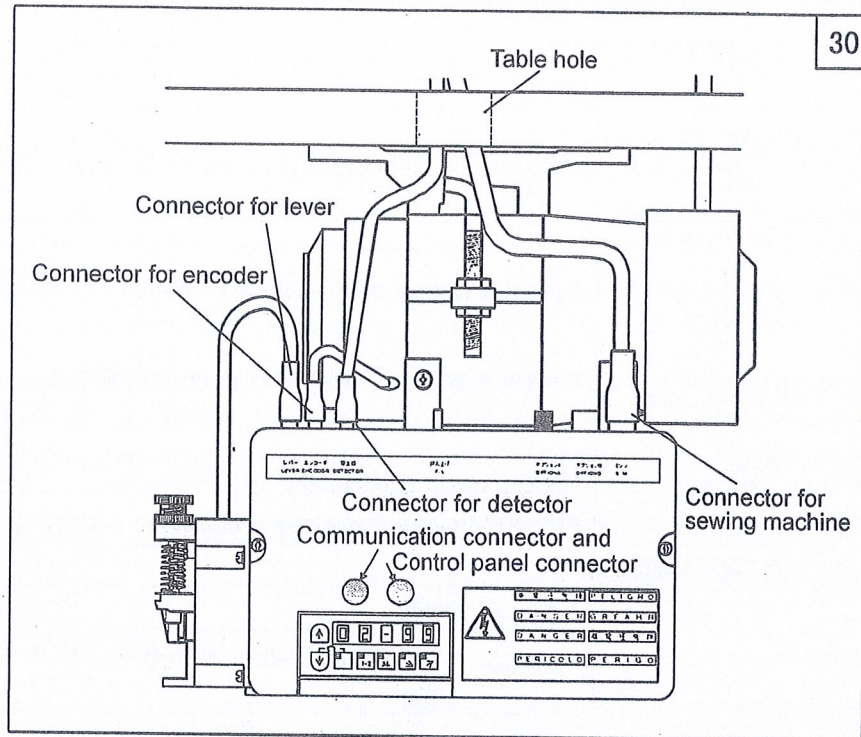

24.REVERSE SEWING (Fig.31)

While sewing, depressing the button switch, it becomes reverse sewing.

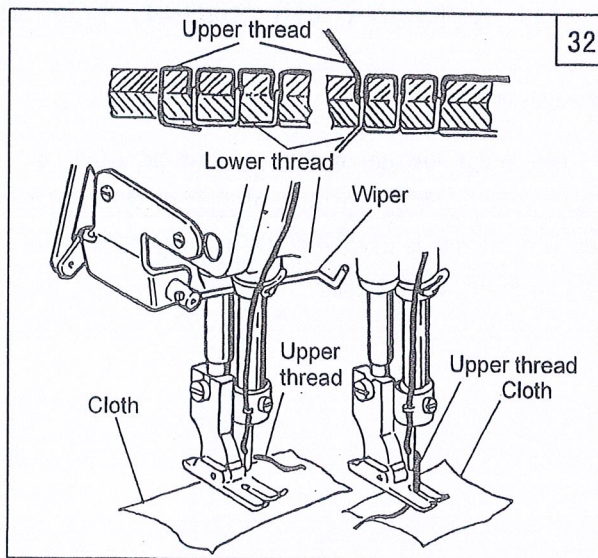
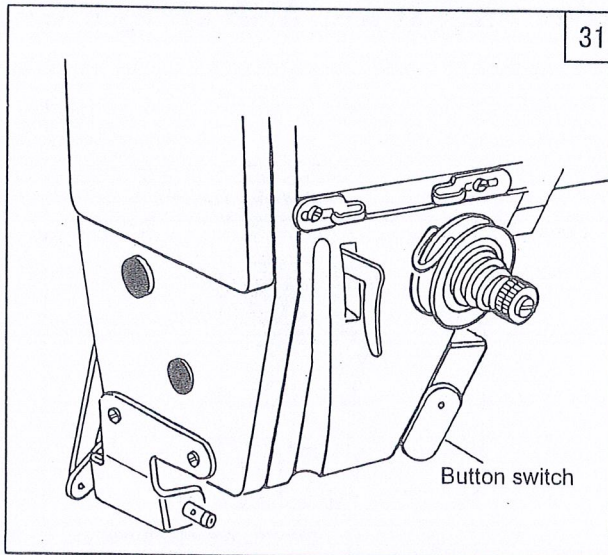

25.THREAD WIPER (Fig.32)

When the thread wiper is operated, the end of upper thread does not remain on the surface of fabric.

26. PEDAL OPERATION

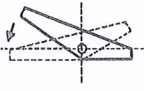
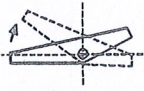
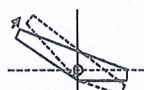
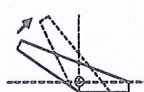
Pedal operation	Operation	
 Neutral-Toe down	The sewing machine will rotate at a speed that is relevant to the toe down amount.	
 Toe down-Neutral	1 position setting: Needle UP position stop 2 Position setting: Needle DOWN position stop	
 Neutral-Light heeling	Presser foot lifter operation (The XC-EN uses a one-step heeling specification. Light heeling)	
 Neutral-Full heeling	1 position setting	
	EMFY	The motor rotates once, trims the thread, and then the presser foot rises
	EN	Operation of needle UP position stop
	2 position setting	
EMFY	The motor half-rotates from the DOWN position, trims the thread, and then the presser foot rises.	
EN	Needle UP position with half-rotation.	

27. ADJUSTMENT OF PEDAL TOE DOWN PRESSURE, AND HEELING PRESSURE

The pedal toe down force can be adjusted by changing the hooking position of spring (A) to the lever. (Five levels is available) Turn the screw bolt to adjust the spring (B) pressure.

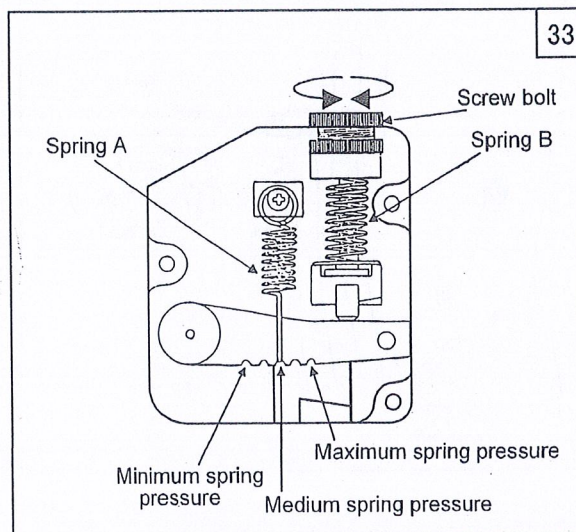

A. ARM BED AND ITS ACCESSORIES

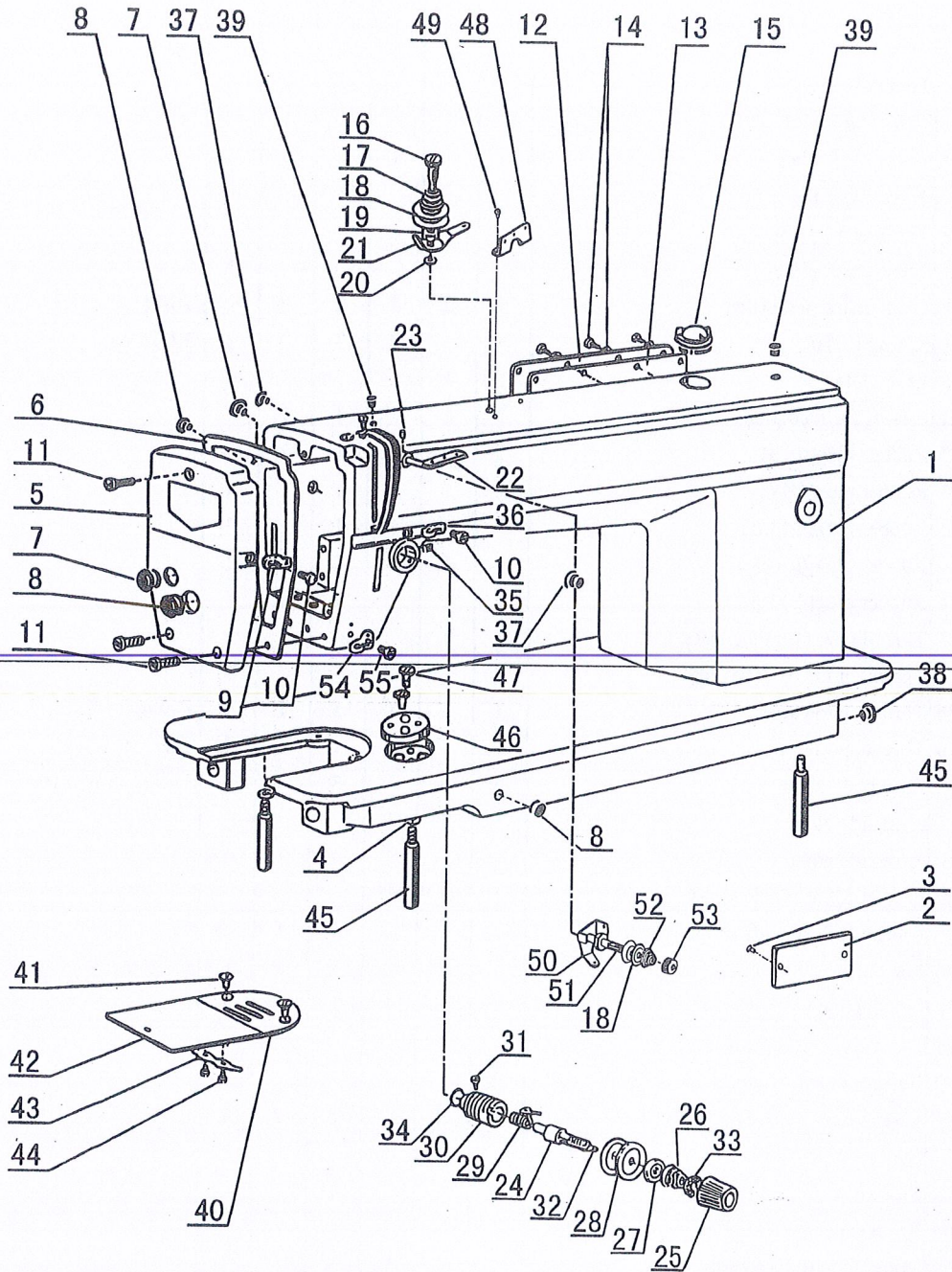

A.ARM BED AND ITS ACCESSORIES

Fig. No.	Part No.	Description	M	H	B	M D 3	H D 3	B D 3	Remarks
A01	H1204B0065	Arm	1						
A01	H1304B0065	Arm		1					
A01	H1404B0065	Arm			1				
A01	H2604B0065	Arm				1	1		
A01	H2804B6512	Arm						1	
A02	H1200B2040	Trade mark plate	1						
A02	H1300B2020	Trade mark plate		1					
A02	H1400B2030	Trade mark plate			1				
A02	H2600B2040	Trade mark plate				1			
A02	H2700B2020	Trade mark plate					1		
A02	H2800B2020	Trade mark plate						1	
A03	H924025050	Trade mark plate rivet	2	2	2	2	2	2	GB/T827 2.5×5
A04	H005008060	Spring washer	3	3	3	3	3	3	GB/T93 6
A05	H1208B0651	Face plate	1	1	1	1	1	1	
A06	H1208B0652	Gasket for face plate	1	1	1	1	1	1	
A07	HA307B0673	Rubber plug(Φ19)	1	1	1	1	1	1	
A07	HA307B0673	Rubber plug(Φ19)	1	1	1	1	1	1	
A08	HA307B0674	Rubber plug(Φ11.8)	1	1	1	1	1	1	
A08	HA307B0674	Rubber plug(Φ11.8)	1	1	1	1	1	1	
A08	HA307B0674	Rubber plug(Φ11.8)	1	1	1	1	1	1	
A09	HA106B0675	Thread guide on face plate	1	1		1	1		
A09	HA607B0671	Thread guide on face plate			1			1	
A10	HA106B0676	Thread guide screw	1	1	1	1	1	1	SM9/64(40)×6
A10	HA106B0676	Thread guide screw	1	1	1	1	1	1	SM9/64(40)×6
A11	HA300B2160	Face plate screw	3	3	3	3	3	3	SM11/64(40)×10
A12	HA308B0681	Arm side cover	1	1	1				
A12	H2609E0671	Arm side cover				1	1	1	
A13	HA108B0682	Gasket for arm side cover	1	1	1				
A13	H2609E0672	Gasket for arm side cover				1	1	1	
A14	HA300B2170	Screw	8	8	8	8	8	8	SM11/64(40)×9
A15	H1210B0671	Oil check window	1	1	1	1	1	1	
A16	HA112B0691	Screw type tension stud	1	1	1				
A17	HA112B0692	Spring for pre-tension	1	1	1				
A18	HA112B0693	Disk for pre-tension	2	2	2	2	2	2	
A19	HA112B0694	Space for pre-tension	1	1	1				
A20	H007013030	Stop ring	1	1	1				GB/T896 3
A21	HA112B0695	Pre-tension thread guide	1	1	1				
A22	HA100B2100	Three-hole thread guide	1	1	1				
A23	HA100B2110	Set screw	1	1	1				SM11/64(40)×5.5
A23	HA100B2110	Set screw				1	1	1	SM11/64(40)×5.5
A24	HA115B0701	Thread tension stud	1	1	1	1	1		SM11/64(40)×6
A24	HA806B0673	Thread tension stud						1	SM1/4(40)
A25	HA310B0701	Thumb nut	1	1	1	1	1	1	

A.ARM BED AND ITS ACCESSORIES

Fig. No.	Part No.	Description	M	H	B	M D 3	H D 3	B D 3	Remarks
A26	HA115B0703	Thread tension spring	1			1			
A26	HA505B0671	Thread tension spring		1					
A26	HA607B0068	Thread tension spring			1				
A26	HA806B0672	Thread tension spring					1	1	
A27	HA310B0702	Thread tension disc	1	1	1	1	1	1	
A28	HA310B0705	Thread tension disc	2	2	2	2	2	2	
A29	HA115B0706	Thread take-up spring	1			1			
A29	HA505B0672	Thread take-up spring		1	1				
A29	HA806B0671	Thread take-up spring					1	1	
A30	HA310B0703	Thread tension regulating bushing	1	1	1				
A30	HA711B0682	Thread tension regulating bushing				1	1	1	
A31	HA115B0708	Set screw	1	1	1				SM9/64(40)×6
A31	HA711B0681	Set screw				1	1	1	SM9/64(40)×6
A32	HA115B0709	Thread tension releasing pin	1	1	1	1	1	1	
A33	HA115B7010	Stop disc	1	1	1	1	1	1	
A34	HA115B7011	Rubber ring	1	1					
A34	HA711B0683	Rubber ring			1	1	1	1	
A35	HA300B2080	Set screw	1	1	1	1	1	1	SM15/64(28)×6.8
A36	HA100B2140	Thread guide	1	1		1	1		
A36	HA600B2050	Thread guide			1			1	
A37	HA300B2090	Rubber plug(Φ8.8)	3	3	3	3	3	3	
A38	HA300B2100	Rubber plug(Φ27)	1	1	1	1	1	1	
A39	HA300B2110	Rubber plug(Φ5.7)	2	2	2	2	2	2	
A40	HA300B2120	Needle plate	1						
A40	HA300B2150	Needle plate	1						
A40	HA500B2030	Needle plate		1				1	
A40	H1100B2060	Needle plate			1				
A40	HA700B2100	Needle plate				1	1		
A41	HA300B2190	Needle plate screw	2	2	2	2	2	2	SM11/64(40)×4.5
A42	HA124B0711	Slide plate	1	1	1	1	1	1	
A43	HA124B0712	Slide plate spring	1	1	1	1	1	1	
A44	HA124B0713	Screw	2	2	2	2	2	2	SM3/32(56)×2.2
A45	HA100B2220	Leg	3	3	3	3	3	3	SM15/64(28)×10
A46	HA300B2140	Cloth guide plate	1	1	1				
A47	HA300B2130	Screw	2	2	2				SM11/64(40)×5.5
A48	HA700B2050	Three-hole thread guide				1	1	1	
A49	HA700B2060	Set screw				1	1	1	SM11/64(40)
A50	HA710B0674	Pre-tension thread guide				1	1	1	
A51	HA710B0673	Screw type tension stud				1	1	1	SM11/64(40)
A52	HA710B0672	Spring for pre-tension				1	1	1	
A53	HA710B0671	Nut				1	1	1	SM11/64(40)
A54	HA500C2060	Thread guide		1	1		1	1	
A55	HA500C2070	Set screw		1	1		1	1	SM9/64(40)×5

B.SEWING MECHANISM

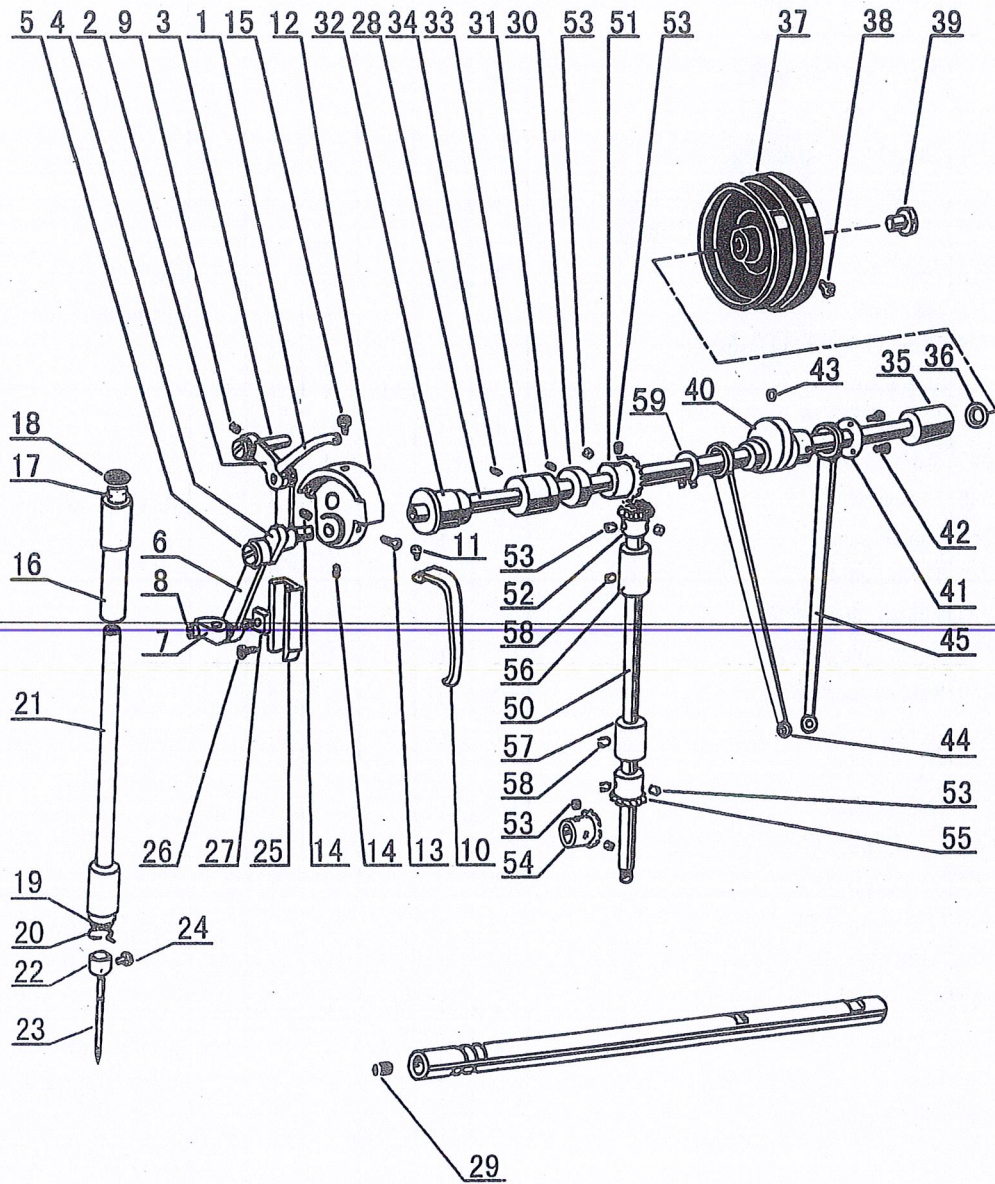

B.SEWING MECHANISM

Fig. No.	Part No.	Description	M	H	B	M D 3	H D 3	B D 3	Remarks
B01	HA1111C104	Thread take-up lever	1			1			
B01	HA3111C104	Thread take-up lever		1			1		
B01	HA6111C104	Thread take-up lever			1			1	
B02	HA104C0652	Thread take-up lever link	1			1			
B02	HA304C0012	Thread take-up lever link		1	1		1	1	
B03	HA104C0653	Hinge pin	1	1	1	1	1	1	
B04	HA104C0654	Thread take-up crank	1			1			
B04	HA504C0651	Thread take-up crank		1	1		1	1	
B04	HA104C0655	Needle bearing	2	2	2	2	2	2	
B05	HA104C0656	Screw(left-handed)	1	1	1	1	1	1	
B06	HA1172C104	Needle bar link	1			1			
B06	HA304C0653	Needle bar link		1	1		1	1	
B07	HA104C0658	Needle bar adaptor	1	1	1	1	1	1	
B08	HA106B0676	Set screw	1	1		1	1	1	SM9/64(40)×6
B08	HA104C0659	Set screw			1				SM9/64(40)×6
B09	HA100C2020	Set screw	1	1	1	1	1	1	SM15/64(28)×10
B10	HA700H2030	Thread take-up guard	1	1		1	1		
B10	HA600C2020	Thread take-up guard			1			1	
B11	HA300C2030	Set screw	1	1	1	1	1	1	SM11/64(40)×8
B12	HA108C0661	Needle bar crank	1			1			
B12	HA307C0661	Needle bar crank		1	1		1	1	
B13	HA100C2060	Set screw	1	1	1	1	1	1	SM9/32(28)×13
B14	HA307C0662	Set screw	2	2	2	2	2	2	SM1/4(40)×6
B15	HA100C2070	Set screw	1	1	1	1	1	1	SM9/32(28)×14
B16	HA100C2080	Needle bar bushing(upper)	1	1	1	1	1	1	
B17	HA100C2100	Felt plug	1	1	1	1	1	1	
B18	HA300C2050	Rubber plug	1	1	1	1	1	1	
B19	HA300C2060	Needle bar bushing(lower)	1			1			
B19	HA804B0652	Needle bar bushing(lower)		1			1	1	
B19	HA500C2050	Needle bar bushing(lower)			1				
B20	HA300C2070	Thread guide	1	1	1	1	1	1	
B21	HA300C2080	Needle bar	1						
B21	HA500C2020	Needle bar		1	1		1	1	
B21	HA705G0066	Needle bar				1			
B22	HA100C2150	Thread guide for needle bar	1			1			
B22	HA500C2030	Thread guide for needle bar		1	1		1	1	
B23	HA100C2160	Needle	1			1			
B23	H1000C2010	Needle		1			1		
B23	HA500C2040	Needle			1			1	
B24	HA100C2170	Needle clamp screw	1	1	1	1	1	1	SM1/8(44)×4.5
B25	HA100C2180	Guide for slide block	1	1	1				
B25	HA704G0065	Guide for slide block				1	1	1	
B26	HA100C2190	Set screw	2	2	2	2	2	2	SM11/64(40)×8

B.SEWING MECHANISM

Fig. No.	Part No.	Description	M	H	B	M D 3	H D 3	Φ D 3	Remarks
B27	HA100C2200	Slide block	1	1	1	1	1	1	
B28	H1204C0651	Arm shaft	1	1	1				
B28	H2604C0651	Arm shaft				1	1	1	
B29	HA104D0652	Rubber plug(Φ7.4×10)	2	2	2	2	2	2	
B30	HA108G0661	Collar for arm shaft	1	1	1	1	1	1	
B31	HA105D0662	Set screw	2	2	2	2	2	2	SM1/4(40)×4
B32	HA100D2030	Arm shaft bushing(left)	1	1	1	1	1	1	
B33	HA100D2040	Arm shaft bushing(middle)	1	1	1	1	1	1	
B34	HA100C2020	Set screw	1	1	1	1	1	1	SM15/64(28)×10
B35	HA300D2020	Arm shaft bushing(right)	1	1	1	1	1	1	
B36	HA306D0066	Oil seal	1	1	1	1	1	1	
B37	HA307D0671	Balance wheel	1	1					
B37	H2000C2040	Balance wheel			1				
B37	HA710R0651	Balance wheel				1	1	1	
B38	HA110D0672	Set screw	2	2	2	2	2	2	SM15/64(28)×12
B39	HA100D2080	Screw	1	1	1				SM11/32(28)×10
B40	HA7311C106	Feed and feed lifting eccentric	1			1			
B40	HA8211C105	Feed and feed lifting eccentric		1	1		1	1	
B41	HA7311C206	Washer	1	1	1	1	1	1	
B42	HA7311C306	Set screw	3	3	3	3	3	3	SM9/64(40)×7
B43	HA100C2020	Set screw	2	2	2	2	2	2	SM15/64(28)×10
B44	HA112D3013	Crank rod for feed lifting rock shaft	1	1	1	1	1	1	
B45	HA7311C506	Crank rod for feed rock shaft	1	1	1	1	1	1	
B50	HA113D0691	Vertical shaft	1	1	1	1	1	1	
B51	HA113B2112	Bevel gear for arm shaft	1	1	1	1	1	1	Z=27
B52	HA113D2122	Bevel gear for vertical shaft(upper)	1	1	1	1	1	1	Z=18
B53	HA108C0663	Set screw	8	8	8	8	8	8	SM1/4(40)×7
B54	HA113D2212	Bevel gear for hook shaft	1	1	1	1	1	1	Z=21
B55	HA113D2222	Bevel gear for vertical shaft(lower)	1	1	1	1	1	1	Z=28
B56	HA100D2110	Vertical shaft bushing(upper)	1	1	1	1	1	1	
B57	HA100D2110	Vertical shaft bushing(lower)	1	1		1	1		
B57	HA600D2010	Vertical shaft bushing(lower)			1			1	
B58	HA100C2020	Set screw	2	2	2	2	2	2	SM15/64(28)×10
B59	HA112D3012	Stop ring	1	1	1	1	1	1	

C. FEEDING AND FEED LIFTING & LOWER SHAFT MECHANISM

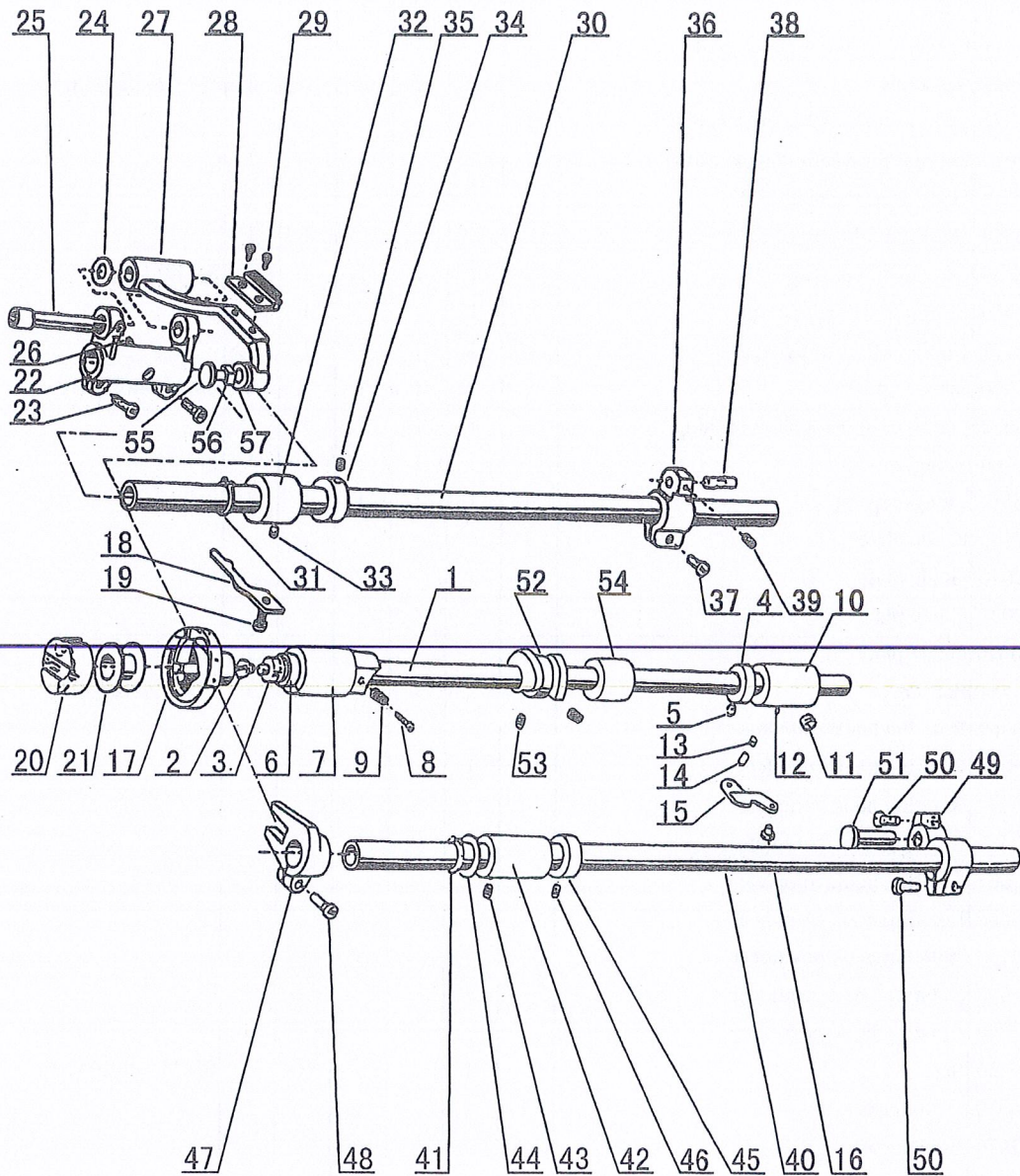

C.FEEDING AND FEED LIFTING & LOWER SHAFT MECHANISM

Fig. No.	Part No.	Description	M	H	B	M D 3	H D 3	B D 3	Remarks
C01	HA304E0651	Rotating hook shaft	1	1					SM3/16(32)×9 SM15/64(28)×4.5 SM15/64(28) SM15/64(28)×10
C01	HA704E0651	Rotating hook shaft				1	1		
C01	HA904E0651	Rotating hook shaft			1			1	
C02	HA1111E104	Filter screw	1	1	1	1	1	1	
C03	HA1111E204	Filter	1	1	1	1	1	1	
C04	HA305E0661	Collar for rotating hook shaft	1	1	1	1	1	1	
C05	HA305E0662	Set screw	2	2	2	2	2	2	
C06	HA106E0071	Oil seal for rotating hook shaft	1	1	1				
C06	HA700E2030	Oil seal for rotating hook shaft				1	1	1	
C07	HA100E2040	Hook shaft bushing(left)	1	1	1				
C07	HA704B0654	Hook shaft bushing(left)				1	1	1	
C08	HA300E2030	Oil adjusting screw	1	1	1	1	1	1	
C09	HA100E2060	Spring for oil adjusting	1	1	1	1	1	1	
C10	HA311E0671	Hook shaft bushing(right)	1	1	1	1	1	1	
C11	HA100C2020	Set screw	1	1	1	1	1	1	
C12	HA110E0672	Oil pipe for hook shaft bushing	1	1	1	1	1	1	
C13	HA300E2100	Plunger	1	1	1	1	1	1	
C14	HA300E2110	Plunger spring	1	1	1	1	1	1	
C15	HA100E2100	Guide plate	1						
C15	HA300E2040	Guide plate		1		1	1		
C15	HA600E2020	Guide plate			1				
C15	HA900M0010	Guide plate						1	
C16	HA104F0654	Set screw	1	1	1	1	1	1	
C17	HA115E0069	Rotating hook complete	1						
C17	HA500E2030	Rotating hook complete		1					
C17	HA600E2070	Rotating hook complete			1				
C17	HA707E0067	Rotating hook complete				1			
C17	HA804E0065	Rotating hook complete					1		
C17	HA906E0066	Rotating hook complete						1	
C18	HA300E2050	Rotating hook positioner	1			1			
C18	HA500E2020	Rotating hook positioner		1			1		
C18	HA600E2040	Rotating hook positioner			1			1	
C19	HA100E2150	Screw	1	1	1	1	1	1	
C20	HA119E0070	Bobbin case	1			1			
C20	HA300E2070	Bobbin case		1					
C20	HA608E0067	Bobbin case			1				
C20	HA805E0066	Bobbin case					1		
C20	HA900E2030	Bobbin case						1	
C21	HA100E2170	Bobbin	1	1		1	1		
C21	HA600E2060	Bobbin			1			1	
C22	HA104G0011	Feed rock shaft crank	1	1	1	1	1	1	
C23	HA104G0012	Screw	2	2	2	2	2	2	
C24	HA104G0656	Washer	1	1	1	1	1	1	

C.FEEDING AND FEED LIFTING & LOWER SHAFT MECHANISM

Fig. No.	Part No.	Description	M	H	B	M D 3	H D 3	β D 3	Remarks
C25	HA705J0654	Shaft for feed bar(eccentric)	1	1	1	1	1	1	
C26	HA100C2190	Screw	1	1	1	1	1	1	SM11/64(40)×8
C27	HA7131J105	Feed bar	1	1	1	1	1	1	
C28	HA104G0653	Feed dog	1	1	1	1	1	1	
C29	HA104G0654	Screw	2	2	2	2	2	2	SM1/8(44)×6
C30	HA300G2050	Feed rock shaft	1	1	1	1	1	1	
C31	H007009150	Stop ring	1	1	1	1	1	1	GB/T894.1 15
C32	HA100G2040	Feed rock shaft bushing	1	1	1	1	1	1	
C33	HA305E0662	Set screw	1	1	1	1	1	1	SM15/64(28)×4.5
C34	HA108G0661	Collar	1	1	1	1	1	1	
C35	HA105D0662	Set screw	2	2	2	2	2	2	
C36	HA7311C706	Feed rock shaft crank(right)	1			1			
C36	HA8211C205	Feed rock shaft crank(right)		1	1		1	1	
C37	HA7311C606	Screw	1	1	1	1	1	1	SM11/64(40)×15
C38	HA706C11B1	Feed rock shaft crank pin	1	1	1	1	1	1	
C39	HA7311C806	Screw	1	1	1	1	1	1	SM11/64(40)×7
C40	HA704K0652	Feed lifting rock shaft	1	1	1	1	1	1	
C41	H007009150	Stop ring	1	1	1	1	1	1	GB/T894.1 15
C42	HA100G2120	Feed lifting rock shaft bushing	1	1	1	1	1	1	
C43	HA100C2020	Set screw	1	1	1	1	1	1	SM15/64(28)×10
C44	HA100G2130	Washer	1	1	1	1	1	1	
C45	HA108G0661	Collar for feed lifting rock shaft	1	1	1	1	1	1	
C46	HA105D0662	Set screw	2	2	2	2	2	2	SM1/4(40)×4
C47	H1204D0651	Feed lifting rock shaft crank(left)	1						
C47	HA7111K104	Feed lifting rock shaft crank(left)		1	1	1	1	1	
C48	HA111G0683	Screw	1	1	1	1	1	1	SM11/64(40)×12
C49	HA705K0661	Feed lifting rock shaft crank(right)	1			1			
C49	HA306G0671	Feed lifting rock shaft crank(right)		1	1		1	1	
C50	HA104G0012	Screw	2	2	2	2	2	2	SM3/16(28)×12
C51	HA100G2070	Hinge pin	1	1	1	1	1	1	
C52	HA710E0691	Thread trimming eccentric				1	1	1	
C53	HA710E0692	Set screw				2	2	2	SM1/4(40)×10
C54	HA704E0653	Hook shaft bushing(middle)				1	1	1	
C55	HA305G1012	Hinge pin for slide block	1	1	1	1	1	1	
C56	HA310G3011	Slide block	1	1	1	1	1	1	
C57	HA310G3012	Washer	1	1	1	1	1	1	

D.STITCH REGULATOR MECHANISM

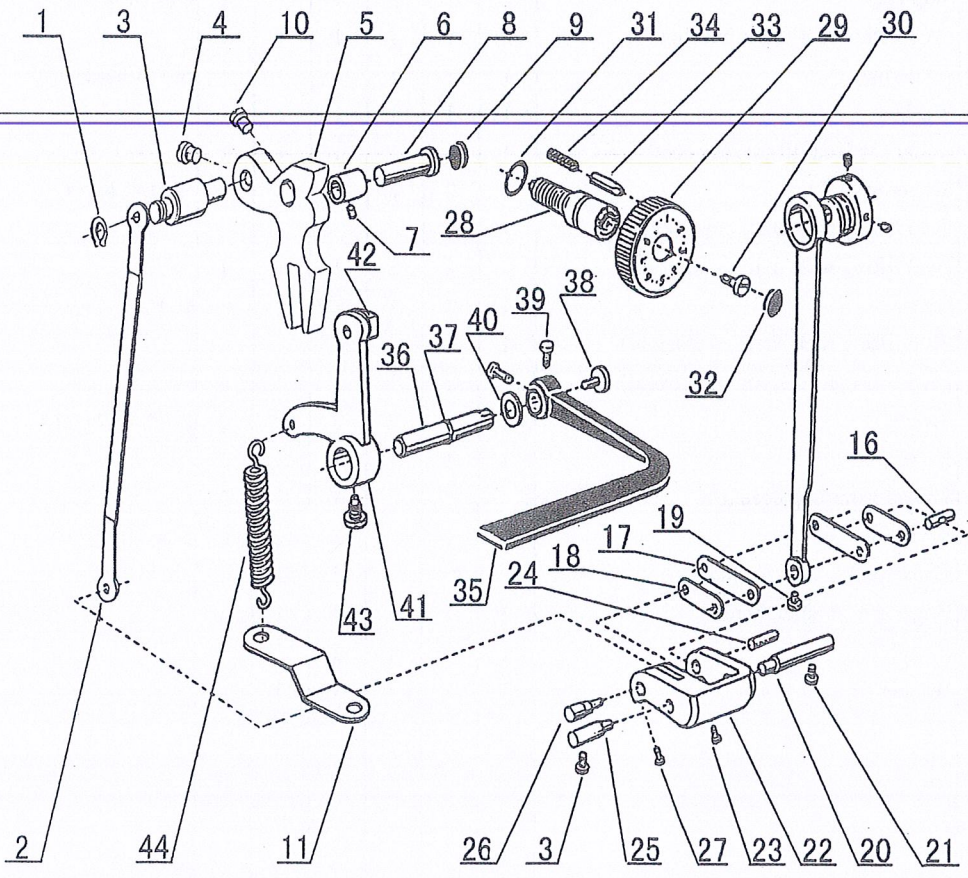
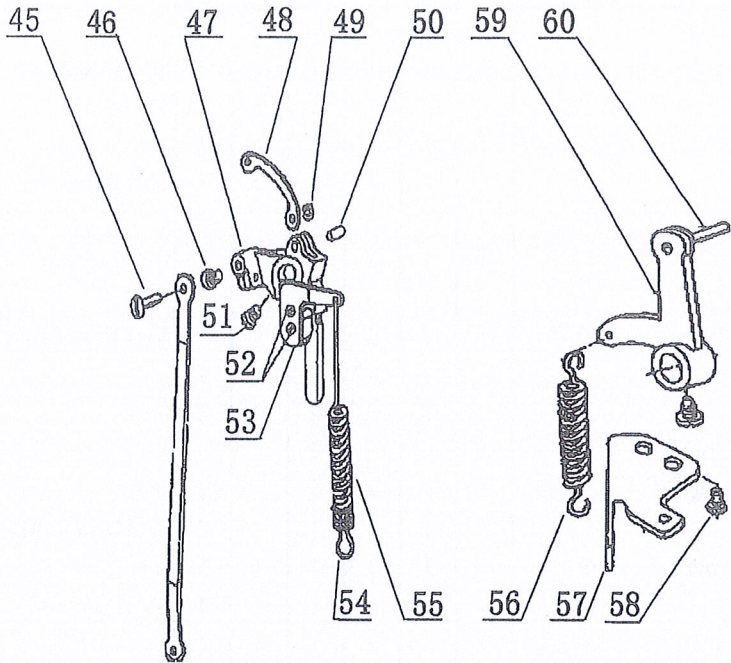

D.STITCH REGULATOR MECHANISM

Fig. No.	Part No.	Description	M	H	B	M D 3	H D 3	B D 3	Remarks
D01	H007013050	Stop ring	1	1	1				
D02	HA7311C406	Feed connecting link	1	1	1	1	1	1	
D03	H1204E0652	Hinge pin	1	1	1				
D04	HA100C2190	Set screw	1	1	1				SM11/64(40)×8
D05	H1204E0651	Feed regulator cam	1						
D05	H1404E0651	Feed regulator cam		1	1				
D06	HA704B0655	Feed regulator bushing	1	1	1	1	1	1	
D07	HA100C2020	Screw	1	1	1	1	1	1	SM15/64(28)×10
D08	HA100F2040	Hinge pin for feed regulator	1	1	1	1	1	1	
D09	HA700B2120	Rubber plug (Φ 20×6)	1	1	1	1	1	1	
D10	HA104F0654	Screw	1	1	1				SM15/64(28)×10
D11	HA100F2140	Spring retainer	1	1	1				
D16	HA706C11B2	Link stud	1	1	1	1	1	1	
D17	HA706C1192	Link(long)	2			2			
D17	HA8211C305	Link(long)		2	2		2	2	
D18	HA706C1191	Link(short)	2	2	2	2	2	2	
D19	HA7311C806	Set screw	1	1	1				SM11/64(40)×7
D20	HA700C2040	Feed regulator shaft(right)	1	1	1	1	1	1	
D21	HA111G0683	Set screw	1	1	1	1	1	1	SM11/64(40)×12
D22	HA7311CG06	Stitch length adjusting crank	1	1	1	1	1	1	
D23	HA7311CD06	Set screw	1	1	1	1	1	1	SM9/64(40)×8.5
D24	HA7311CE06	Link stud	1	1	1	1	1	1	
D25	HA700C2050	Feed regulator shaft(left)	1	1	1	1	1	1	
D26	HA7311CF06	Link stud	1	1	1	1	1	1	
D27	HA7311CC06	Screw	1	1	1	1	1	1	SM9/64(40)×6
D28	HA109F0671	Feed regulator screw bar	1	1	1	1	1	1	
D29	H1205E0661	Dial	1						
D29	HA506F0672	Dial		1			1	1	
D29	H2004F0066	Dial			1				
D29	HA307F0661	Dial				1			
D30	HA109F0673	Screw	1	1	1	1	1	1	SM3/16(28)×8
D31	HA109F0674	O-ring	1	1	1	1	1	1	
D32	HA300F2050	Rubber plug	1	1	1	1	1	1	
D33	HA100F2080	Stopper pin	1	1	1	1	1	1	
D34	HA100F2090	Spring for stopper pin	1	1	1	1	1	1	
D35	HA309F0671	Reverse feed lever	1	1	1	1	1	1	
D36	HA113F3021	Reverse feed lever pin	1	1	1	1	1	1	
D37	HA113F3022	O-ring	1	1	1	1	1	1	
D38	HA113F0683	Screw	1	1	1	1	1	1	SM3/16(28)×6.5
D39	HA104F0654	Screw	2	2	2	2	2	2	SM15/64(28)×10
D40	HA100F2110	Washer	1	1	1	1	1	1	
D41	HA115F0691	Reverse feed lever crank	1	1	1				
D42	HA115F4011	Reverse feed lever crank pin	1	1	1				

D.STITCH REGULATOR MECHANISM

Fig. No.	Part No.	Description	M	H	B	M D 3	H D 3	B D 3	Remarks
D43	HA100F2130	Screw	1	1	1	1	1	1	SM15/64 (28) × 8
D44	HA115F0692	Spring	1	1	1				
D45	HA700C2060	Pin				1	1	1	
D46	HA111G0683	Screw				1	1	1	
D47	H2604E0651	Feed regulator				1			
D47	H2704E0651	Feed regulator					1	1	
D48	H2204D0651	Link for resrve feed				1	1	1	
D49	H007013040	E-type ring				1	1	1	
D50	H2204D0652	Pin				1	1	1	
D51	HA113F0684	Screw				1	1	1	
D52	HA100C2190	Screw				2	2	2	
D53	H2600E2020	Spring retainer				1	1	1	
D54	HA806C0675	Spring holder				1	1	1	
D55	HA806C0674	Coil spring				1	1	1	
D56	H2600E2050	Spring				1	1	1	
D57	HA800F2010	Spring holder				1	1	1	
D58	HA800F2020	Screw				1	1	1	
D59	H2605E0661	Crank				1	1	1	
D60	H2207D0671	Slide block pin				1	1	1	

E.PRESSER FOOT MECHANISM

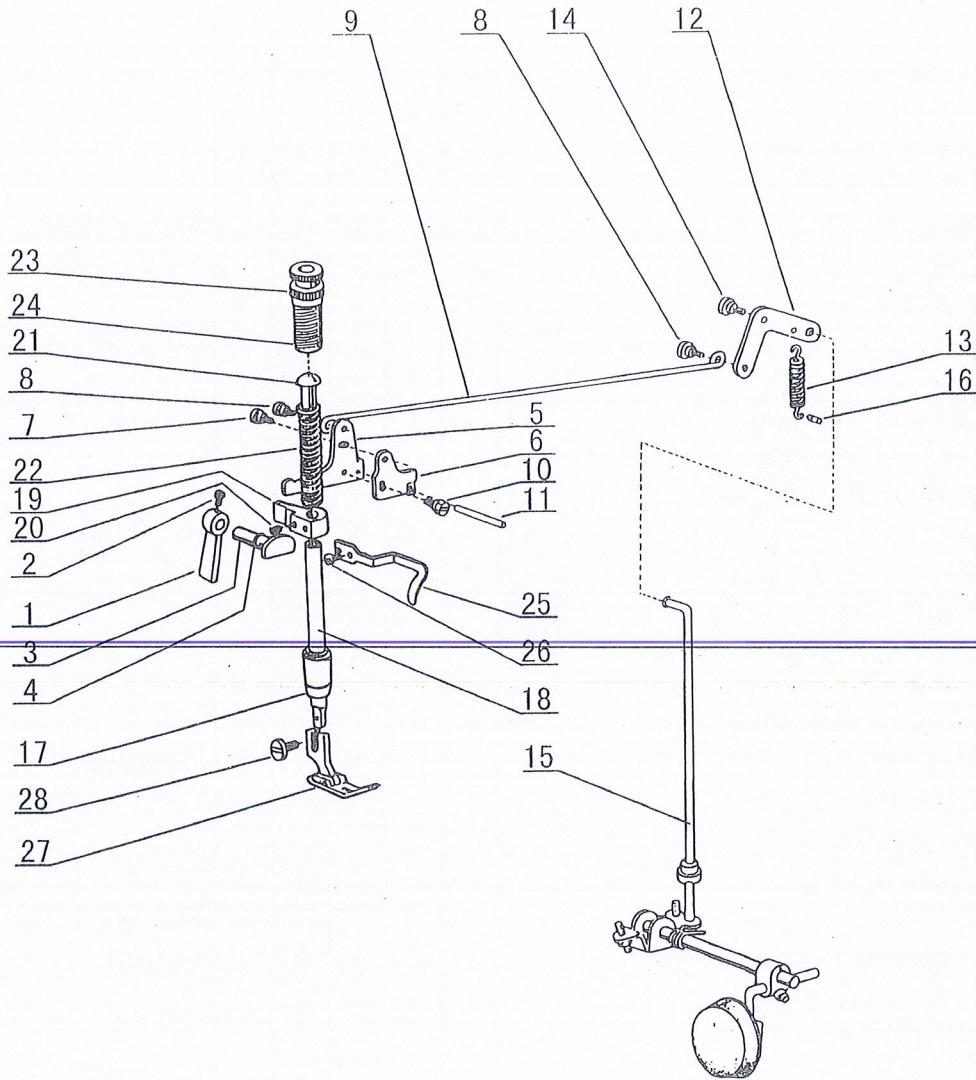

E.UPPER SHAFT & PRESSER FOOT MECHANISM

Fig. No.	Part No.	Description	M	H	B	M D 3	H D 3	B D 3	Remarks
E01	H1204F0651	Presser bar lifter	1	1	1				
E01	HA704I0652	Presser bar lifter				1	1	1	
E02	HA300B2170	Set screw	1	1	1				SM11/64(40)×5.5
E02	HA100B2010	Set screw				1	1	1	SM11/64(40)×5.5
E03	H1205F0661	Presser bar lifter cam	1	1	1				
E03	HA705I0661	Presser bar lifter cam				1	1	1	
E04	HA300H2080	O-ring	1	1	1	1	1	1	
E05	HA107H1011	Knee lifter lever(left)	1	1	1				
E05	HA7311I106	Knee lifter lever(left)				1	1	1	
E06	HA305H6611	Tension releasing cam	1	1	1	1	1	1	
E07	HA107H1013	Screw	1	1	1	1	1	1	SM11/64(40)×6.5
E08	HA107H0662	Screw	2	2	2	2	2	2	SM3/16(28)×3.5
E09	HA107H0663	Knee lifter rod	1	1	1	1	1	1	
E10	HA100H2050	Screw	1	1	1	1	1	1	SM15/64(28)×13
E11	HA100H2060	Tension releasing pin	1	1	1	1	1	1	
E12	HA110H0671	Knee lifter lever(right)	1	1	1				
E12	HA306H0067	Knee lifter lever(right)				1	1	1	
E13	HA110H0672	Spring for knee lifter lever	1	1	1	1	1	1	
E14	HA100H2050	Screw	1	1	1	1	1	1	SM15/64(28)×10
E15	HA306H0671	Knee lifter connecting rod	1	1	1	1	1	1	
E16	HA100H2080	Pin for spring	1	1	1	1	1	1	
E17	HA300H2090	Presser bar bushing	1	1	1	1	1	1	
E18	HA300H2110	Presser bar	1	1	1	1	1	1	
E19	HA307H0671	Presser bar lifting bracket	1	1	1	1	1	1	
E20	HA3411D308	Screw	1	1	1	1	1	1	SM15/64(28)×7
E21	HA100H2120	Presser bar spring guide	1	1	1	1	1	1	
E22	HA100H2130	Presser bar spring	1	1	1				
E22	HA500H2010	Presser bar spring				1	1	1	
E23	HA117H0692	Lock nut	1	1	1	1	1	1	SM1/2(28)
E24	HA309H0681	Pressure regulating thumb screw	1	1	1	1	1	1	SM1/2(28)
E25	HA300H2120	Upper thread guide	1	1	1				
E25	HA700I2090	Upper thread guide				1	1	1	
E26	HA100C2040	Set screw	1	1	1	1	1	1	SM11/64(40)×5.5
E27	HA310H0069	Presser foot complete	1	1		1	1		
E27	H1104H0065	Presser foot complete			1			1	
E28	HA100H2150	Screw	1	1	1	1	1	1	SM9/64(40)×11

F.OIL LUBRICATION MECHANISM

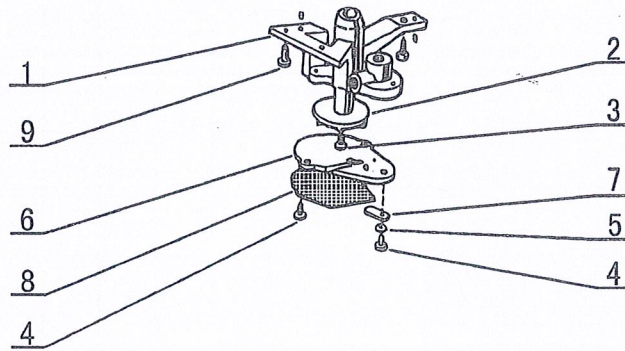
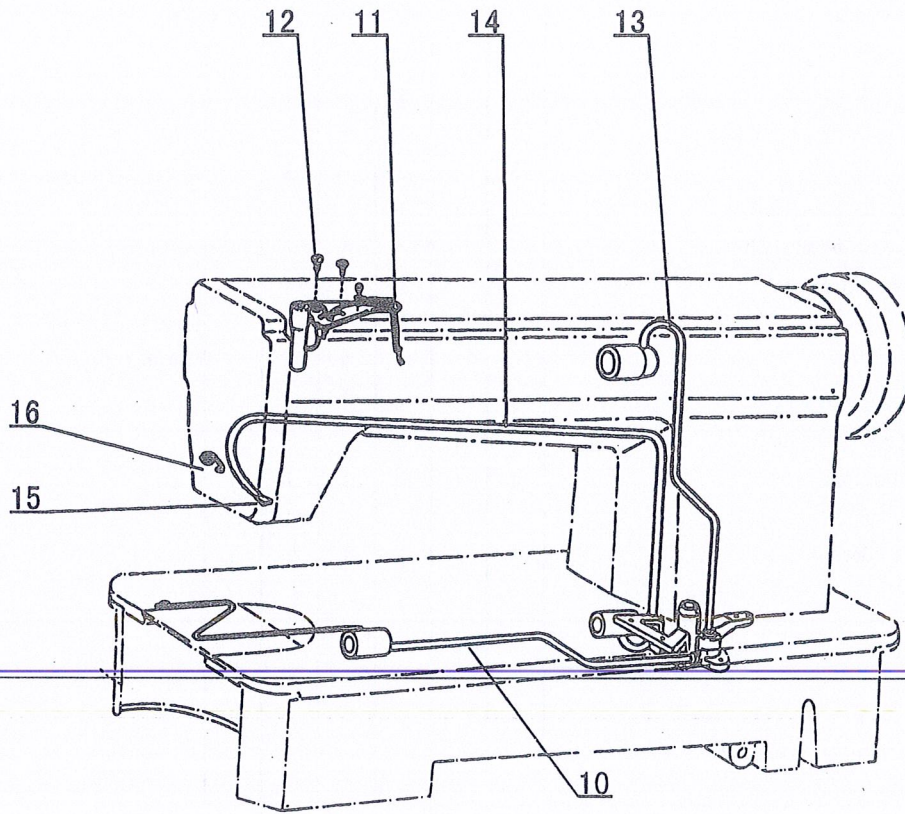

F.OIL LUBRICATION MECHANISM

Fig. No.	Part No.	Description	M	H	B	M D 3	H D 3	B D 3	Remarks
F01	HA100I2010	Oil pump body	1	1	1	1	1	1	
F02	HA100I2020	Oil pump impeller	1	1	1	1	1	1	
F03	HA100I2030	Screw	1	1	1	1	1	1	SM1/8(44)×6.5
F04	HA300I2050	Screw	3	3	3	3	3	3	SM1/8(44)×13
F05	HA100I2050	Spring washer	1	1	1	1	1	1	
F06	HA100I2060	Oil pump fitting plate	1	1	1	1	1	1	
F07	HA100I2070	Oil adjusting plate	1	1	1	1	1	1	
F08	HA111I0065	Oil pump screen complete	1	1	1	1	1	1	
F09	HA100I2090	Screw	3	3	3	3	3	3	SM11/64(40)×13
F10	HA113I0066	Oil pipe for hook shaft	1	1	1				
F10	HA707L0065	Oil pipe for hook shaft				1	1	1	
F11	HA304I0065	Oil braid fitting plate	1	1	1	1	1	1	
F12	HA100I2120	Screw	2	2	2				SM9/64(40)×11
F12	HA100H2150	Screw				2	2	2	SM9/64(40)×8
F13	HA116I0068	Oil pipe for arm shaft	1			1	1	1	
F13	H5604G0065	Oil pipe for arm shaft		1	1				
F14	HA305I0661	Oil return pipe	1	1	1	1	1	1	
F15	HA100I2150	Felt pouch	1	1	1	1	1	1	
F16	HA300I2060	Piper holder	1	1	1	1	1	1	

G.KNIFE ACTUATING MECHANISM

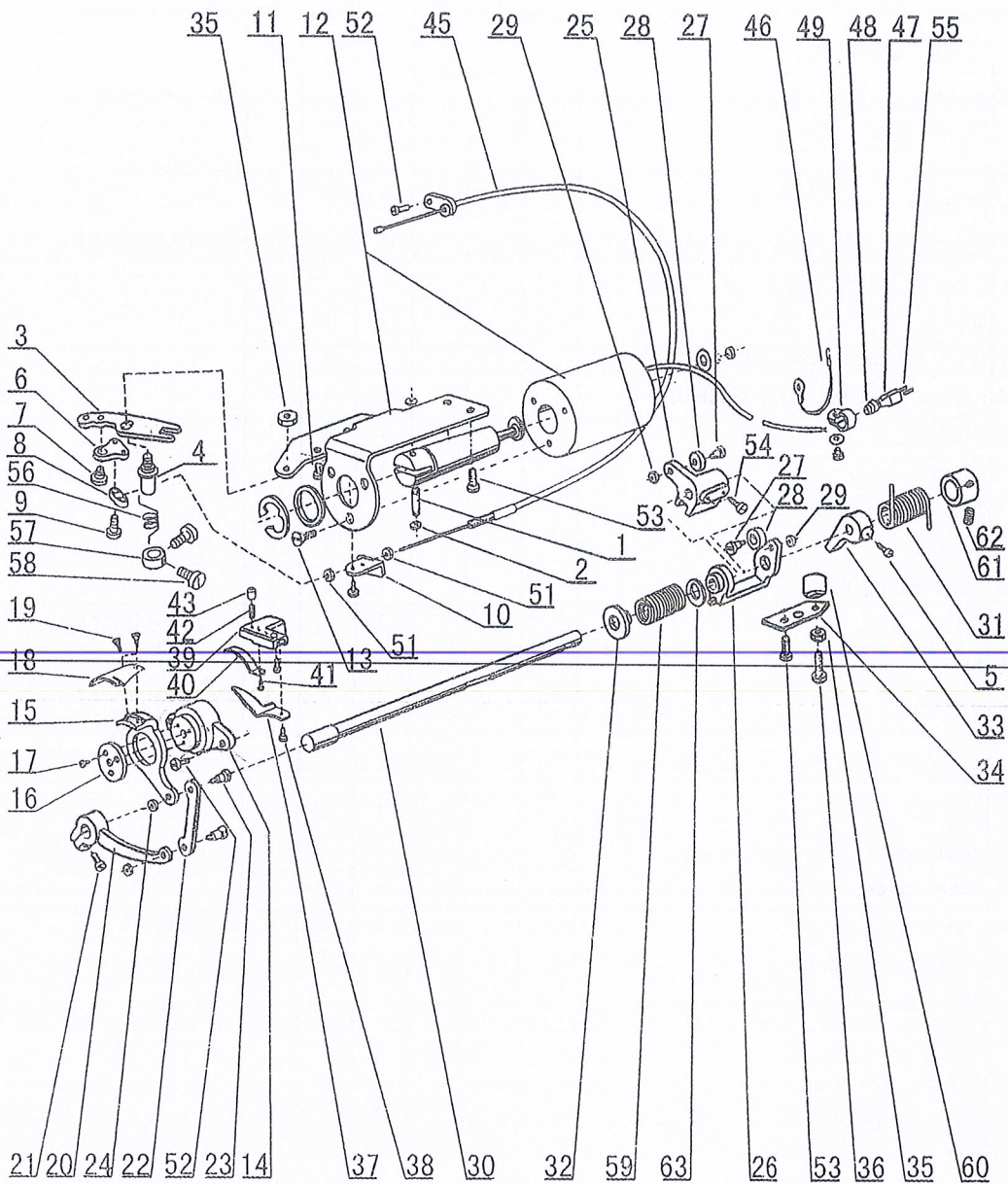

G.KNIFE ACTUATING MECHANISM

Fig. No.	Part No.	Description	M	H	B	M	H	B	Remarks
						D 3	D 3	D 3	
G01	HA712N0692	Link stud				1	1	1	
G02	H007013040	Stop ring				2	2	2	GB/T896 4
G03	HA712N0698	Thread trimmer driving lever				1	1	1	
G04	HA712N0695	Stud screw				1	1	1	
G05	HA113F0684	Screw				1	1	1	SM15/64(28)×8.5
G06	HA712N6910	Flexible wire holder				1	1	1	
G07	HA712N0699	Screw				1	1	1	SM11/64(40)×5
G08	HA712N6911	Flexible wire presser				1	1	1	
G09	HA712N6912	Screw				2	2	2	SM1/8(44)×7
G10	HA712N6913	Holder				1	1	1	
G11	HA100E2150	Screw				1	1	1	SM11/64(40)×10
G12	H2606H7101	Solenoid bracket assy.				1	1	1	
G13		Screw				1	1	1	
G14	HA704N1111	Knife holding bracket saddle				1	1	1	
G15	HA704N1112	Knife holding bracket saddle(left)				1	1	1	
G16	HA704N1113	Washer				1	1	1	
G17	HA704N1114	Screw				3	3	3	SM1/8(44)×5.2
G18	HA7111N804	Movable knife(left)				1	1	1	
G19	HA7111N704	Screw				2	2	2	SM11/64(40)
G20	HA7111N604	Knife driving crank				1	1	1	
G21	HA719B7011	Screw				1	1	1	SM11/64(40)×11.4
G22	HA7111N404	Link				1	1	1	
G23	HA7111N204	Screw				2	2	2	SM11/64(40)×6.2
G24	HA7111N304	Nut				2	2	2	SM11/64(40)
G25	HA7211N106	Crank 1				1	1	1	
G26	HA7211N206	Crank 2				1	1	1	
G27	HA7221N206	Crank screw				2	2	2	
G28	HA7221N106	Crank roller				2	2	2	
G29	HA706N0663	Nut				2	2	2	SM3/16(28)
G30	HA700N0020	Knife driving shaft				1	1	1	
G31	HA700N0110	Coil spring				1	1	1	
G32	HA700N0050	Bushing				1	1	1	
G33	HA709N0671	Stopper lever				1	1	1	
G34	HA710N0682	Lever stopper plate				1	1	1	
G35	HA710N0683	Nut				1	1	1	SM15/64(28)
G36	HA7411N110	Screw				1	1	1	SM15/64(28)×23
G37	HA7121N404	Thread finger				1	1	1	
G38	HA7311CH06	Screw				3	3	3	SM9/64(40)×8
G39	HA7121N104	Bracket for fixed blade				1	1	1	
G40	HA7121N204	Fixed blade				1	1	1	
G41	HA7121N304	Screw				1	1	1	SM9/64(40)×3.1
G42	HA7121N604	Screw				1	1	1	SM9/64(40)×8.5
G43	HA7121N704	Nut				1	1	1	SM9/64(40)

G.KNIFE ACTUATING MECHANISM

Fig. No.	Part No.	Description	M	H	B	M D 3	H D 3	g D 3	Remarks
G45	HA713N0702	Flexible wire assy.				1	1	1	
G46	HA705Q0065	Ground wire assy.				1	1	1	
G47	HA700Q0010	Pin				1	1	1	
G48	HA704O0657	Rubber plug				1	1	1	
G49	HA708P0668	Cord holder				1	1	1	
G51	H003002050	Nut				2	2	2	GB/T6170 M5
G53	HA700N0080	Screw				1	1	1	SM15/64(28)×12
G54	HA113F0684	Screw				2	2	2	SM15/64(28)×8.5
G55	HA7641B319	Tie-in				2	2	2	
G56	HA712N0697	Trimming lever spring				1	1	1	
G57	HA712N0696	Collar				1	1	1	
G58	HA7311CC06	Screw				2	2	2	SM9/64(40)×6
G59	HA700N0040	Coil spring				1	1	1	
G60	HA7411N210	Stopper rubber				1	1	1	
G61	HA715N0711	Collar				1	1	1	
G62	HA105D0662	Set screw				1	1	1	SM1/4(40)×4
G63	HA706N0664	Washer				1	1	1	

H. WIPER MECHANISM

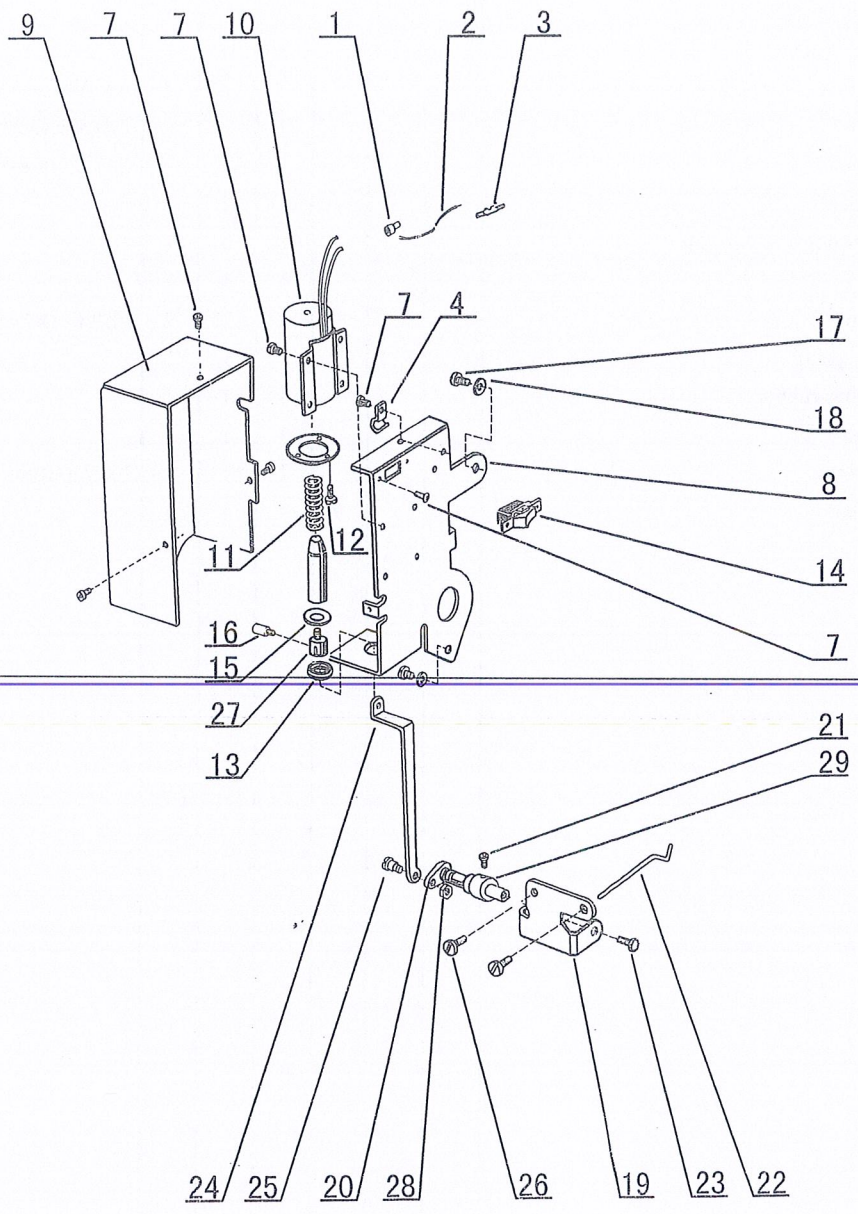

H.WIPER MECHANISM

Fig. No.	Part No.	Description	M	H	B	M 1	H 1	B 1	Remarks
H01	HA708P6610	Tie-in				1	1	1	
H02	HA708P1011	Cord assy.				1	1	1	
H03	HA7641B319	Tie-in				2	2	2	
H04	HA700P0060	Code holder				1	1	1	
H07	HA708P0669	Screw				10	10	10	
H08	HA708P0667	Solenoid bracket				1	1	1	
H09	HA708P0666	Solenoid cover for wiper mech.				1	1	1	
H10	HA7221P108	Wiper solenoid				1	1	1	
H11	HA708P0663	Spring				1	1	1	
H12	HA7221P508	Screw				3	3	3	
H13	HA708P0664	Rubber cushion				1	1	1	
H14	HA708P0665	Thread wiper switch				1	1	1	
H15	HA7221P308	Retaine washer				1	1	1	
H16	HA700P0030	Plunger pin				1	1	1	
H17	HA104F0654	Screw				2	2	2	SM15/64(28)×10
H18	HA700P0010	Washer				2	2	2	
H19	HA705P0651	Thread wiper bracket				1	1	1	
H20	HA710P0671	Wiper shaft				1	1	1	
H21	HA100C2170	Screw				1	1	1	
H22	HA705P0653	Thread wiper				1	1	1	
H23	HA104G0654	Screw				1	1	1	SM1/8(44)×6
H24	HA705P0654	Thread wiper connecting rod				1	1	1	
H25	HA710P0674	Screw				1	1	1	
H26	HA700B2030	Screw				2	2	2	SM11/64(40)×11
H27	HA7221P408	Screw				1	1	1	M8
H28	HA710P0673	Nut				1	1	1	
H29	HA710P0672	Collar				1	1	1	

I. TOUCH BACK MECHANISM & DETECTOR MECHANISM

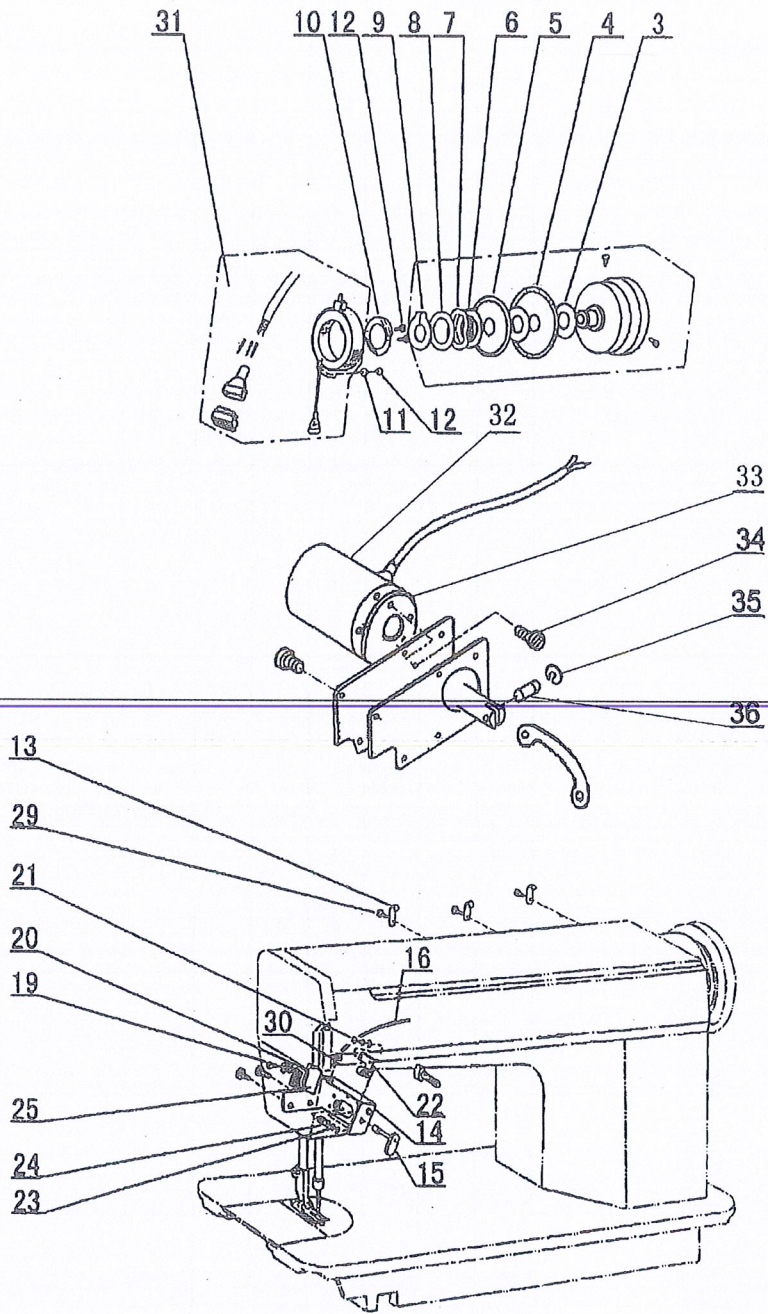

I.TOUCH BACK MECHANISM & DETECTOR MECHANISM

Fig. No.	Part No.	Description	M	H	B	M D 3	H D 3	B D 3	Remarks
I03	HA700R0030	Spacer 1				2	2	2	
I04	HA700R0010	Speed command disc 1				1	1	1	
I05	HA700R0020	Speed command disc 2				1	1	1	
I06	HA700R0040	Spacer 2				1	1	1	
I07	HA700R0050	Supporter spring				1	1	1	
I08	HA700R0060	Washer				1	1	1	
I09	H007009300	Stop ring				1	1	1	
I10	HA703R0066	Detector bracket supporter				1	1	1	
I11	HA703R0067	Washer				1	1	1	
I12	HA300C2030	Screw				3	3	3	SM11/64(40)×8
I13	HA700Q0030	Cord holder				3	3	3	
I14	HA704O0651	Bracket for touch switch				1	1	1	
I15	HA704O0021	Push button				1	1	1	
I16	HA7161O104	Cord assy.				1	1	1	
I19	HA704O6510	Screw				2	2	2	
I20	HA704O0655	Micro switch				1	1	1	
I21	HA704O0659	Screw				2	2	2	
I22	HA704O0654	Plate spring				1	1	1	
I23	H007013030	Stop ring				2	2	2	
I24	HA704O0653	Coil spring				1	1	1	
I25	HA704O0658	Insulator seet				1	1	1	
I29	HA300B2170	Screw				2	2	2	
I30	HA704O0657	Rubber plug				1	1	1	
I31	HA700R0000	Detector bracket assay HA703R0065				1	1	1	
I32	H2611E8001	Solenoid assay for touch black				1	1	1	
I33	H2609E0674	Washer				1	1	1	
I34	HA300C2160	Screw				4	4	4	
I35	H007013040	E-type ring				1	1	1	
I36	HA712N0692	Pin				1	1	1	

J.ACCESSORIES

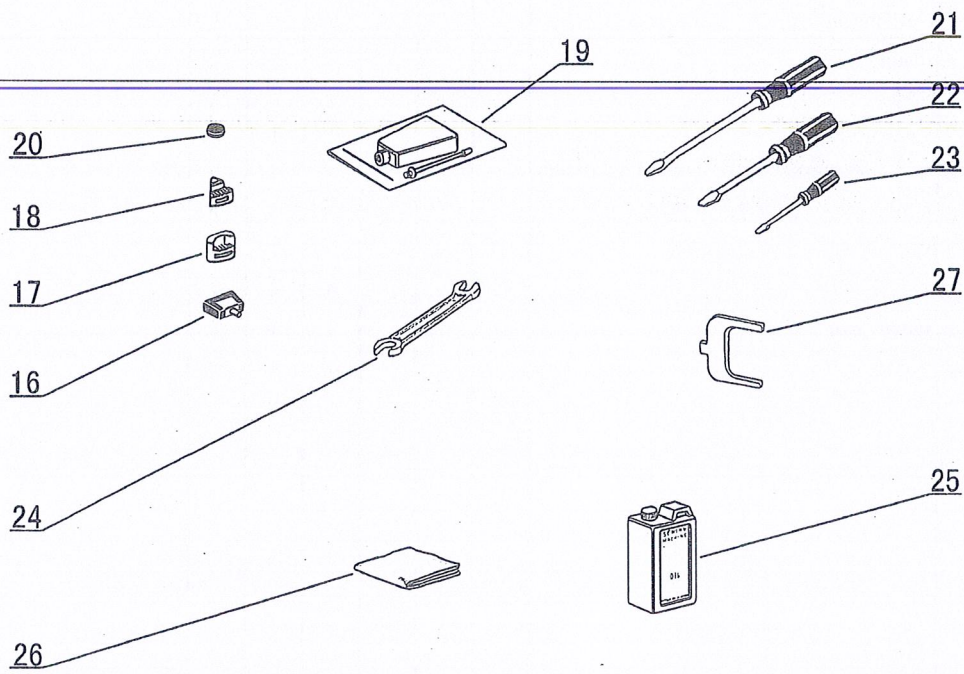
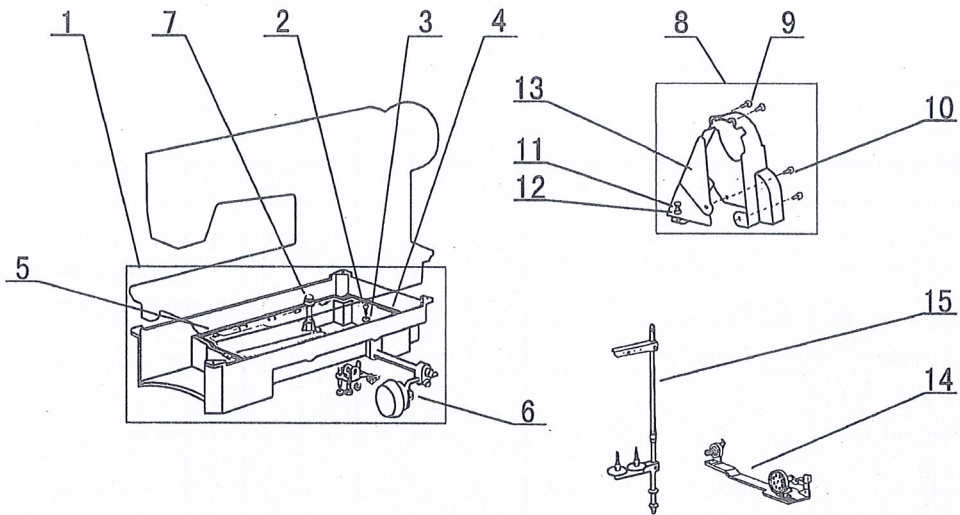

J.ACCESSORIES

Fig. No.	Part No.	Description	M	H	B	M D 3	H D 3	B D 3	Remarks
J01	HA304J0065	Oil reservoir	1	1	1				
J01	H2600L0000	Oil reservoir				1	1	1	
J02	HA104J0652	Oil drain screw	1	1	1	1	1	1	SM5/16(28)×10
J03	HA104J0653	Washer	1	1	1	1	1	1	
J04	HA104J0654	Gasket for oil reservoir(small)	1	1	1	1	1	1	
J05	HA104J0655	Gasket for oil reservoir(large)	1	1	1	1	1	1	
J06	HA106J0066	Knee lifter complete	1	1	1	1	1	1	
J07	HA106J0661	Knee lifter lifting rod	1	1	1	1	1	1	
J08	HA305J0066	Belt cover complete	1	1	1	1	1	1	
J09	HA300B2170	Screw	2	2	2	2	2	2	SM11/64(40)×8
J10	HA300J2280	Screw	2	2	2	2	2	2	SM15/64(28)×8
J11	H801045200	Screw	2	2	2	2	2	2	GB/T99 4.5×20
J12	HA300J2230	Washer	2	2	2	2	2	2	
J13	HA305J0663	Belt cover	1						
J13	HA305J0665	Belt cover		1	1				
J14	HA109J0068	Bobbin winder assy.	1	1		1	1		
J14	HA905S0066	Bobbin winder assy.			1			1	
J15	HA200J2030	Thread stand assy.	1	1	1	1	1	1	
J16	HA307J0067	Table hinge with rubber cushion	1	1	1	1	1	1	
J17	HA300J2050	Vibration preventing rubber	2	2	2	2	2	2	
J18	HA300J2060	Vibration preventing rubber	2	2	2	2	2	2	
J19	HA100J2110	Oil with oiler	1	1	1	1	1	1	
J20	HA100J2120	Magnet block for reservoir	1	1	1	1	1	1	
J21	HA300J2070	Screw driver(large)	1	1	1	1	1	1	
J22	HA300J2200	Screw driver(middle)	1	1	1	1	1	1	
J23	HA300J2210	Screw driver(small)	1	1	1	1	1	1	
J24	HA300J2220	Double-ended spanner	1	1	1	1	1	1	
J25	HA300J2170	Oil box	1	1	1	1	1	1	
J26	HA100J2180	Cover	1	1	1	1	1	1	
J27	HA704S0654	Speed command disc adjusting plate				1	1	1	

